

## GROUP 90

**CIRCUIT DIAGRAMS**

## CONTENTS

HOW TO READ CIRCUIT DIAGRAMS .....	90-4	MFI SYSTEM <3.0L ENGINE-A/T> ..	90-66
JUNCTION BLOCK .....	90-10	COOLING SYSTEM <2.4L ENGINE>.	90-76
JOINT CONNECTOR.....	90-12	COOLING SYSTEM <3.0L ENGINE>.	90-78
CENTRALIZED JUNCTION.....	90-13	INVECS-II 4A/T <VEHICLES WITHOUT SPORT MODE TYPE> .....	90-80
POWER DISTRIBUTION SYSTEM ..	90-20	INVECS-II 4A/T <VEHICLES WITH SPORT MODE TYPE (2.4L ENGINE) >.....	90-88
STARTING SYSTEM <M/T> .....	90-26	INVECS-II 4A/T <VEHICLES WITH SPORT MODE TYPE (3.0L ENGINE) >.....	90-98
STARTING SYSTEM <A/T>.....	90-27	HEADLIGHT .....	90-108
IGNITION SYSTEM <2.4L ENGINE-M/T> .....	90-28	TAILLIGHT, POSITION LIGHT, REAR SIDE MARKER LIGHT AND LICENSE PLATE LIGHT .....	90-112
IGNITION SYSTEM <2.4L ENGINE-A/T>.....	90-29	FOG LIGHT.....	90-116
IGNITION SYSTEM <3.0L ENGINE-M/T> .....	90-30	DOME LIGHT AND LUGGAGE COMPARTMENT LIGHT <ECLIPSE>	90-120
IGNITION SYSTEM <3.0L ENGINE-A/T>.....	90-31	DOME LIGHT AND TRUNK LIGHT <ECLIPSE SPYDER> .....	90-124
CHARGING SYSTEM <M/T>.....	90-32	TURN-SIGNAL LIGHT AND HAZARD WARNING LIGHT.....	90-128
CHARGING SYSTEM <A/T> .....	90-34	STOPLIGHT .....	90-132
MFI SYSTEM <2.4L ENGINE-M/T> ..	90-36	BACKUP LIGHT <M/T> .....	90-134
MFI SYSTEM <2.4L ENGINE-A/T> ..	90-46	BACKUP LIGHT <A/T> .....	90-135
MFI SYSTEM <3.0L ENGINE-M/T> ..	90-56		

HORN .....	90-136	AUDIO SYSTEM <VEHICLES WITH AMPLIFIER> ....	90-208
METER AND GAUGE .....	90-138	MULTI CENTER DISPLAY .....	90-214
BRAKE WARNING LIGHT, OIL PRESSURE WARNING LIGHT, FUEL WARNING LIGHT .....	90-140	CIGARETTE LIGHTER .....	90-218
POWER WINDOWS <ECLIPSE> ...	90-142	ACCESSORY SOCKET .....	90-219
POWER WINDOWS <ECLIPSE SPYDER> .....	90-146	AUTO-CRUISE CONTROL SYSTEM <2.4L ENGINE-M/T> .....	90-220
CENTRAL DOOR LOCKING SYSTEM <VEHICLES WITHOUT KEYLESS ENTRY SYSTEM> .....	90-150	AUTO-CRUISE CONTROL SYSTEM <2.4L ENGINE-A/T> .....	90-224
CENTRAL DOOR LOCKING SYSTEM <VEHICLES WITH KEYLESS ENTRY SYSTEM (WITHOUT THEFT-ALARM SYSTEM) > .....	90-154	AUTO-CRUISE CONTROL SYSTEM <3.0L ENGINE-M/T> .....	90-228
CENTRAL DOOR LOCKING SYSTEM <VEHICLES WITH KEYLESS ENTRY SYSTEM (WITH THEFT-ALARM SYSTEM) > .	90-162	AUTO-CRUISE CONTROL SYSTEM <3.0L ENGINE-A/T> .....	90-232
HEATER .....	90-170	ANTI-LOCK BRAKING SYSTEM (ABS) <VEHICLES WITHOUT TCL> .....	90-236
AIR CONDITIONING SYSTEM <2.4L ENGINE> .....	90-174	ANTI-LOCK BRAKING SYSTEM (ABS) <VEHICLES WITH TCL> .....	90-240
AIR CONDITIONING SYSTEM <3.0L ENGINE> .....	90-180	SUPPLEMENTAL RESTRAINT SYSTEM (SRS) <VEHICLES WITHOUT SIDE AIR BAG> .....	90-244
WINDSHIELD WIPER AND WASHER	90-188	SUPPLEMENTAL RESTRAINT SYSTEM (SRS) <VEHICLES WITH SIDE AIR BAG>..	90-246
REAR WIPER AND WASHER <M/T>	90-192	POWER SEAT .....	90-248
REAR WIPER AND WASHER <A/T>	90-196	THEFT-ALARM SYSTEM .....	90-250
DEFOGGER <ECLIPSE> .....	90-200	FORGOTTEN KEY PREVENTION FUNCTION .....	90-258
DEFOGGER <ECLIPSE SPYDER>..	90-202	LIGHTING MONITOR TONE ALARM	90-262
REMOTE CONTROLLED MIRROR..	90-203	KEY REMINDER TONE ALARM ....	90-264
AUDIO SYSTEM <VEHICLES WITHOUT AMPLIFIER> .....	90-204	SEAT BELT TONE ALARM .....	90-266
		IMMOBILIZER SYSTEM <2.4L ENGINE-M/T> .....	90-268

---

IMMOBILIZER SYSTEM <2.4L ENGINE-A/T>.....	90-270	SUNROOF.....	90-276
IMMOBILIZER SYSTEM <3.0L ENGINE-M/T> .....	90-272	RHEOSTAT.....	90-279
IMMOBILIZER SYSTEM <3.0L ENGINE-A/T>.....	90-274	CONVERTIBLE TOP .....	90-280
		UNIVERSAL GARAGE DOOR OPENER .....	90-284

# HOW TO READ CIRCUIT DIAGRAMS

M1901000100083

The circuit of each system from the fuse (or fusible link) to ground is shown. The power supply is shown at the top and the ground at the bottom to facilitate understanding of how the current flows.

Indicates power source.

Indicates that terminal is connected via a plate in the relay box.

Each circuit diagram consists of block(s). The blocks are divided by page number.

Indicates splice point numbers. These numbers are identical to those described in "Splice Locations."

Indicates the circuit name to be connected. The arrow indicates the current flow direction.

Indicates the power supply in the control unit. If no voltage is displayed, this indicates battery positive voltage.

An "X" at the end of a connector number indicates that the connector is connected to a centralized junction that is shown in the section "Centralized Junction."

Indicates that the diagram continues at ▽ which belongs to the [2] block in the same circuit.

Indicates the connector symbol. Connectors in the circuit diagram are indicated in numerical order.

Indicates connector number. The same number as used in the wiring harness diagram. Connector and connector numbers are shown at the lower part of the page. Connector numbers not enclosed by frame indicate the device incorporated into wiring harness.

Indicates the circuit name to be connected. The arrow indicates the current flow direction.

Indicates the operating conditions of the engine coolant switch, etc.

Indicates shield wire.

Indicates that current flows upwards.

TSB Revision

ACX02361AB

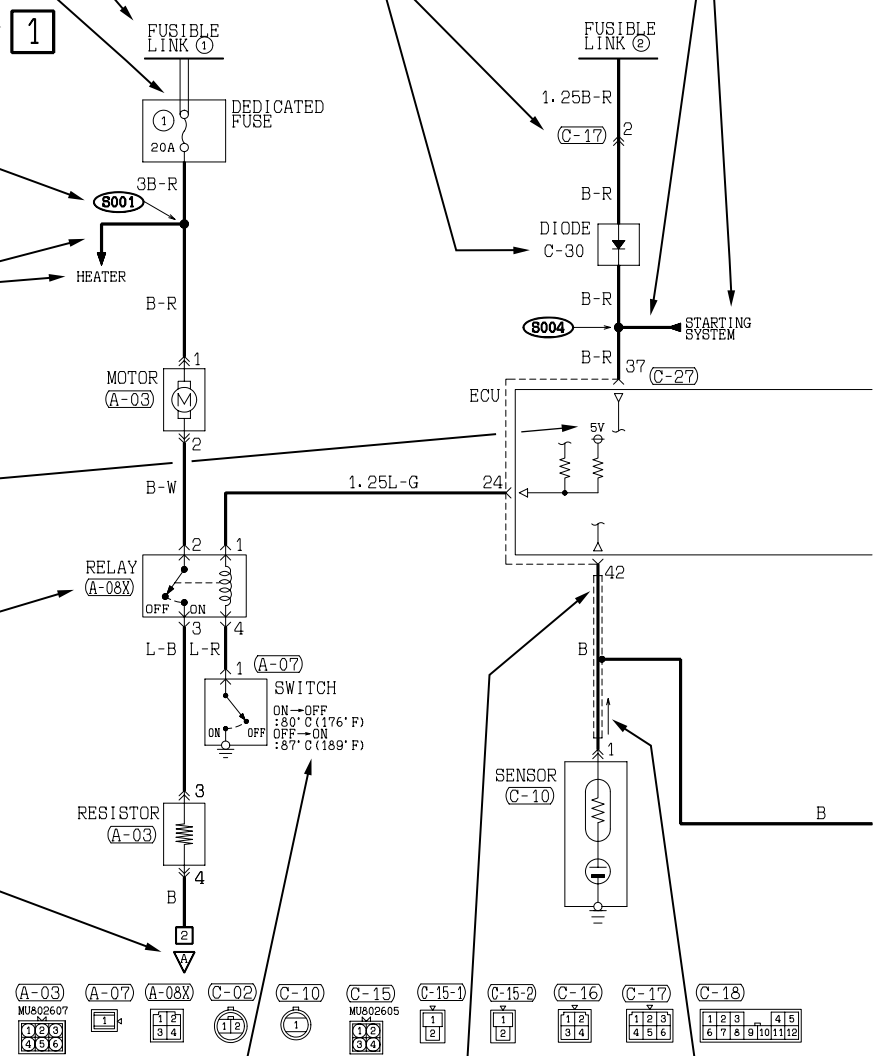



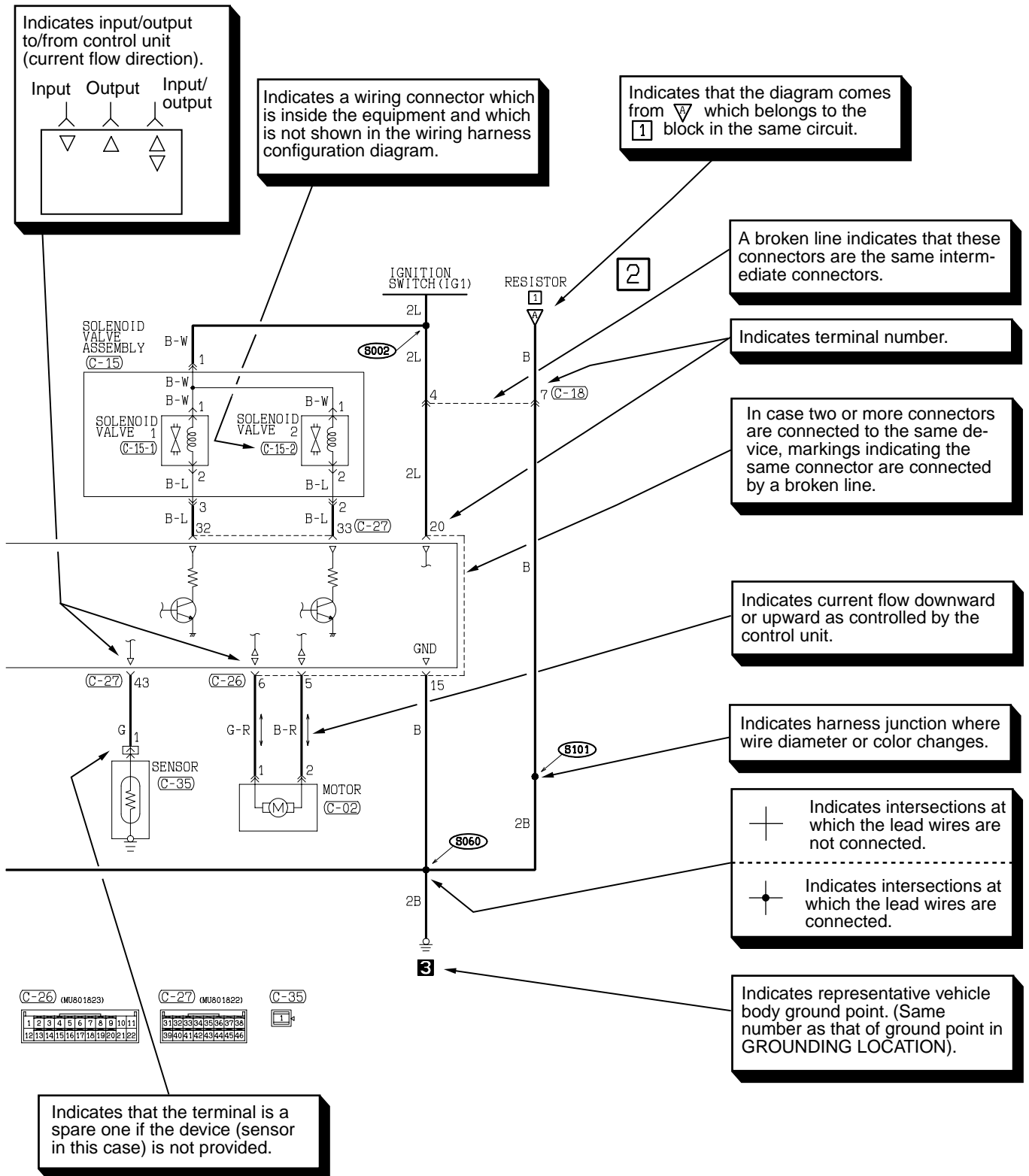

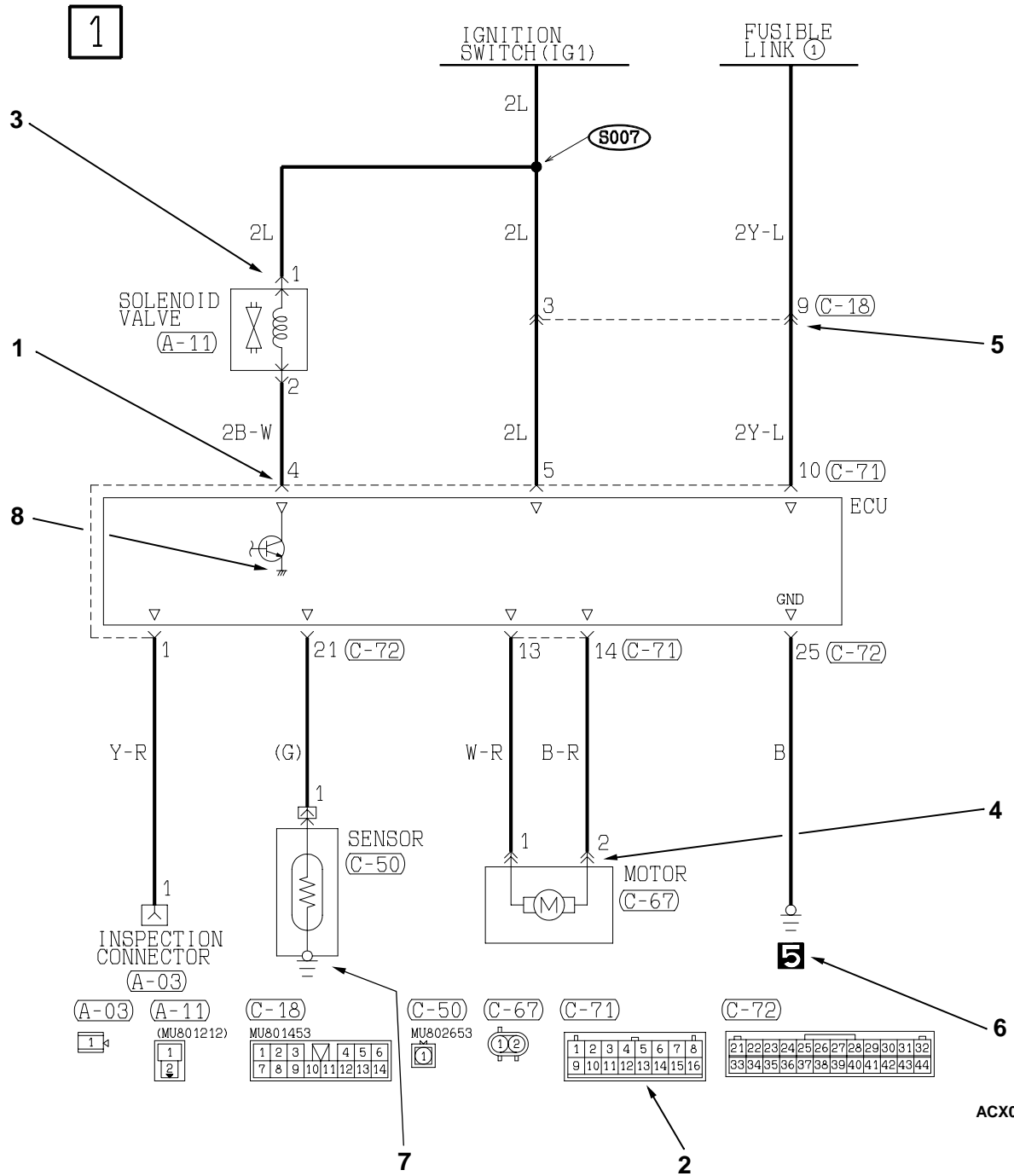

- (A-03) MU&C2607  
1 2 3  
4 5 6
- (A-07) [Symbol]  
1 2
- (A-08X) 1 2  
3 4
- (C-02) 1 2
- (C-10) 1
- (C-15) MU&C2605  
1 2  
3 0
- (C-15-1) 1  
2
- (C-15-2) 1  
2
- (C-16) 1 2  
3 4
- (C-17) 1 2 3  
4 5 6
- (C-18) 1 2 3 4 5  
6 7 8 9 10 11 12



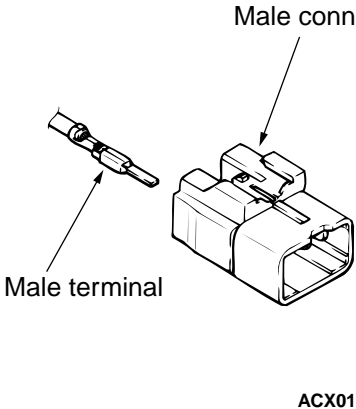

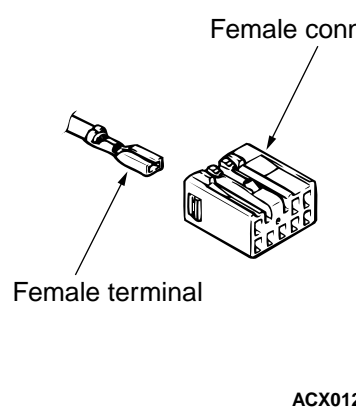
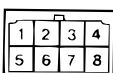
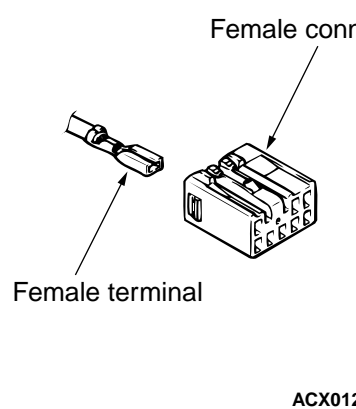

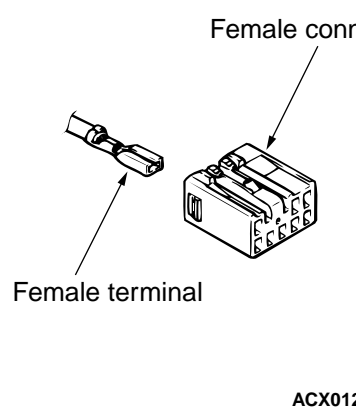
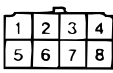
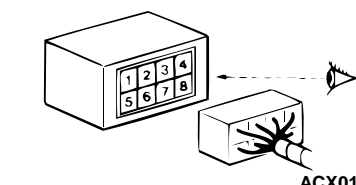
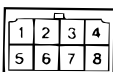
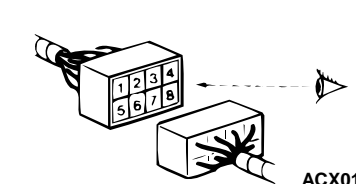

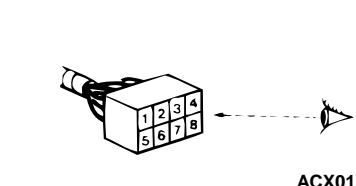
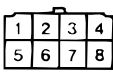

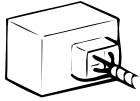
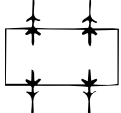
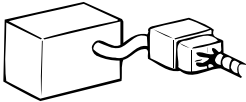
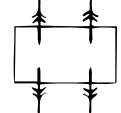
CONNECTOR/GROUNDING INDICATIONS



TSB Revision





















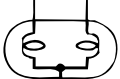

ITEM	NO.	CONNECTOR/ GROUNDING	SYMBOL	CONTENTS
Connector and terminal marking	1		Male terminal  ACX01252 AB	The male and female terminals are indicated as shown. The connector with male terminal(s) is called as male connector and indicated by two connector contour lines, while the connector with female terminal(s) is called as female connector and indicated by single connector contour line.
			Male connector  ACX01253 AB	
			Female terminal  ACX01255 AB	
			Female connector  ACX01256 AB	
Connector symbol marking	2	Device 	 ACX01253	The symbol indicates the connector is viewed as shown. At a device connection, the connector symbol on the device side is shown. For an intermediate connector, the male connector symbol is shown. For spare connectors and check connectors, no device is connected, and so the harness-side connector symbol is shown for these connectors. For the data link connector, its contents differ from the previous description. Refer to "scan tool operation instruction" in detail.
		Intermediate connector 		
		Spare connector, check connector 	 ACX01256	

ITEM	NO.	CONNECTOR/ GROUNDING	SYMBOL	CONTENTS
Connector connection marking	3	Direct connection type   ACX01260 AB	 ACX01261	Connection between a device and the harness is either by direct insertion in the device (direct connection type) or by connection with a harness connector furnished on the device side furnished (harness connection type). The two types are indicated as illustrated.
	4	Harness connection type   ACX01262 AB	 ACX01263	
	5	Intermediate connector   ACX01264 AB	 ACX01265	
Ground markings	6	Body ground   ACX01273 AB	 ACX01274	Grounding is either by body ground, device ground or control unit interior ground. These are indicated as illustrated.
	7	Device ground   ACX01275 AB	 ACX01276	
	8	Ground in control unit   ACX01277 AB	 ACX01278	

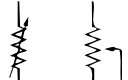
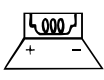

**SYMBOLS (EXCEPT CONNECTOR AND GROUNDING)**

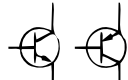
Devices appearing in circuit diagrams are indicated by the following symbols.

battery  ACX02377AB	buzzer  ACX02378AB	Capacitor  ACX02379AB	electrolytic capacitor  ACX02380AB	Variable capacitor  ACX02381AB	Coil  ACX02382AB
diode  ACX02383AB	light emitting diode  ACX02384AB	photo diode  ACX02385AB	Zener diode  ACX02386AB	dual bulb  ACX02387AB	Single bulb  ACX02388AB
Fuse  ACX02389AB	Fusible link  ACX02390AB	horn  ACX02391AB	motor  ACX02392AB	Pulse generator  ACX02393AB	Piezoelectric device  ACX02394AB
Resistor  ACX02395AB	Variable resistor  ACX02396AB	Speaker  ACX02397AB	Thermistor  ACX02398AB	Transistor  ACX02399AB	photo transistor  ACX02400AB

**WIRE COLOR CODES**

Wire color are identified by the following color codes.

CODE	WIRE COLOR	CODE	WIRE COLOR	CODE	WIRE COLOR	CODE	WIRE COLOR
B	Black	L	Blue	R	Red	Y	Yellow
BR	Brown	LG	Light green	SB	Sky blue	-	-
G	Green	O	Orange	V	Violet	-	-
GR	Gray	P	Pink	W	White	-	-

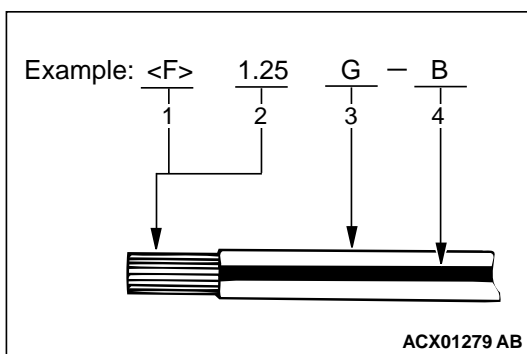

If a cable has two colors, the first of the two color code characters indicates the basic color (color of the cable coating) and the second indicates the marking color.

NO.	MEANING
1	<F>: Flexible wire <T>: Twisted wire
2	Wire size (mm <sup>2</sup> )*
3	Basic color (color of the cable coating)
4	Marking color

**NOTE:**

\*: No code indicates 0.5 mm<sup>2</sup>(0.0008 in<sup>2</sup>). Cable color code in parentheses indicates 0.3 mm<sup>2</sup> (0.0005 in<sup>2</sup>).

# JUNCTION BLOCK

M1901000200080

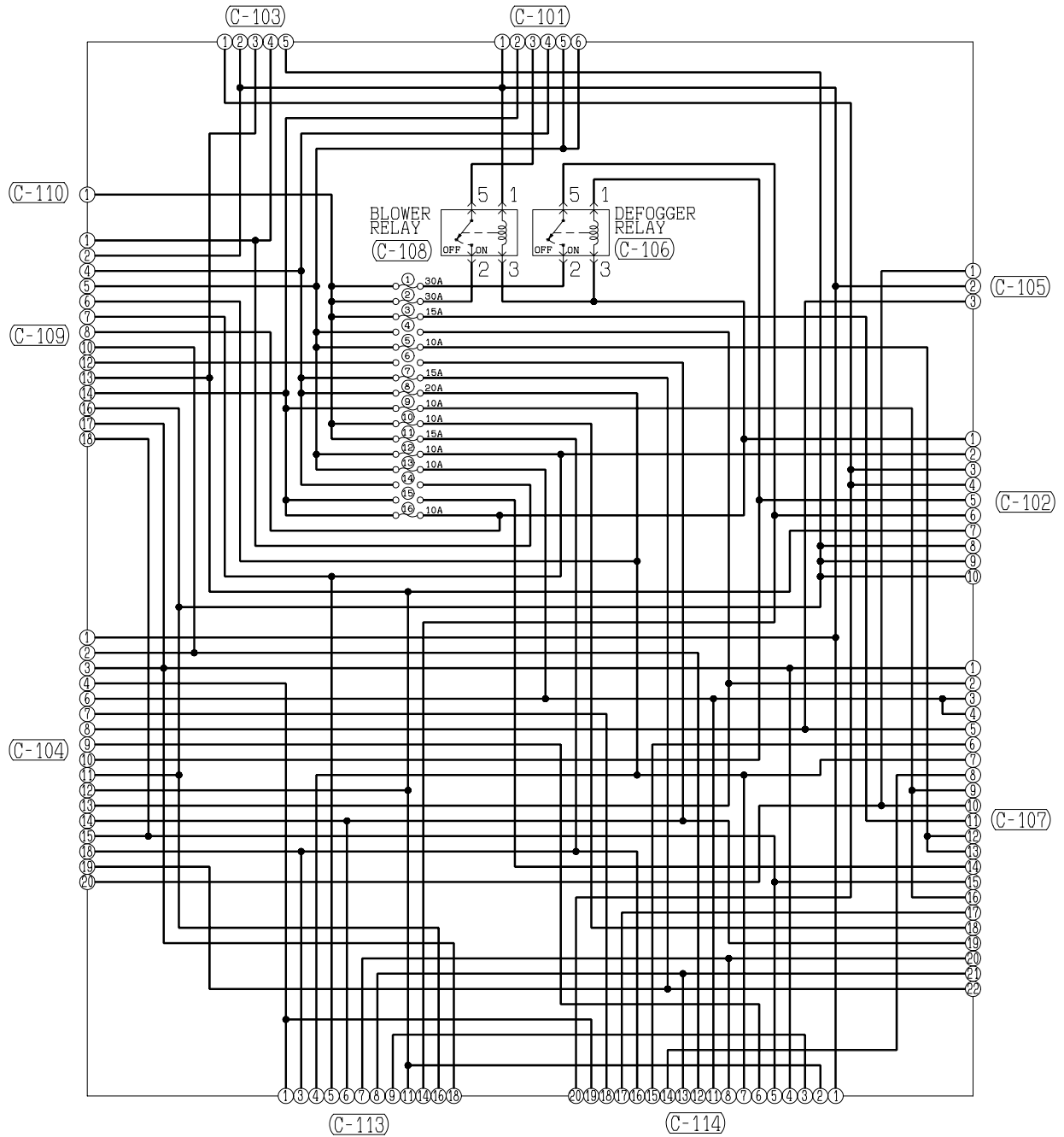

NOTE  
CONNECTOR NUMBERS ARE KEYED TO THE CONFIGURATION  
DIAGRAM (DASH PANEL) AND EACH CIRCUIT DIAGRAM.

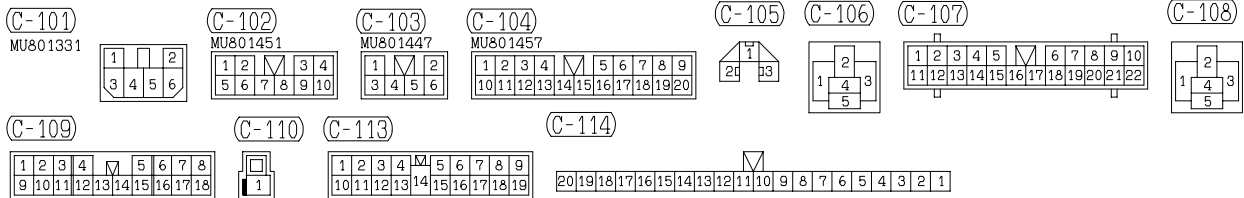

H1S00M04AA

TSB Revision

**FRONT SIDE**

**REAR SIDE**

TO INSTRUMENT  
PANEL WIRING HARNESS

TO INSTRUMENT PANEL  
WIRING HARNESS

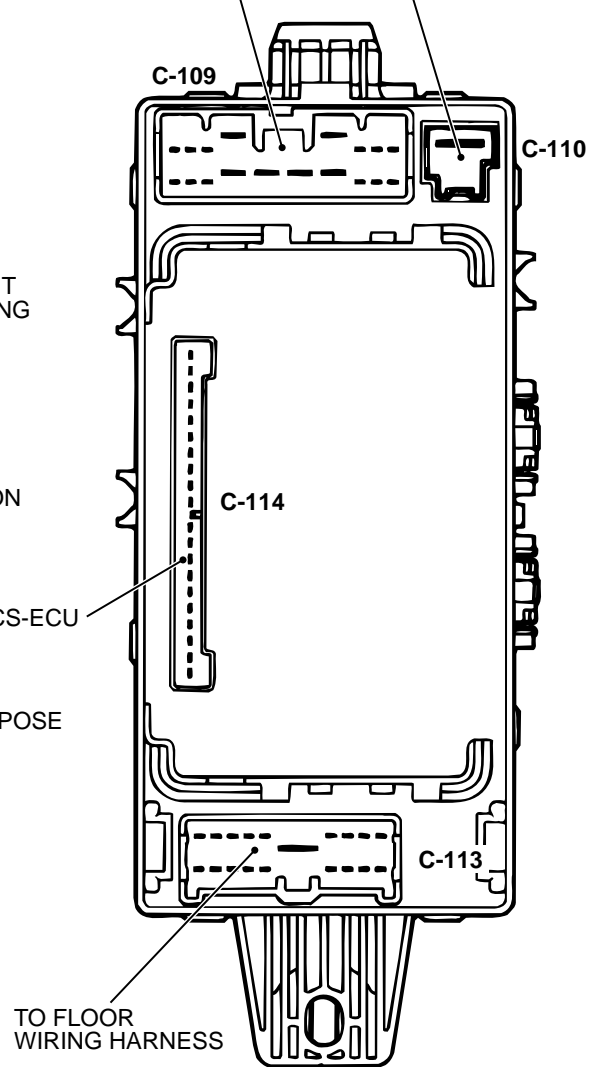
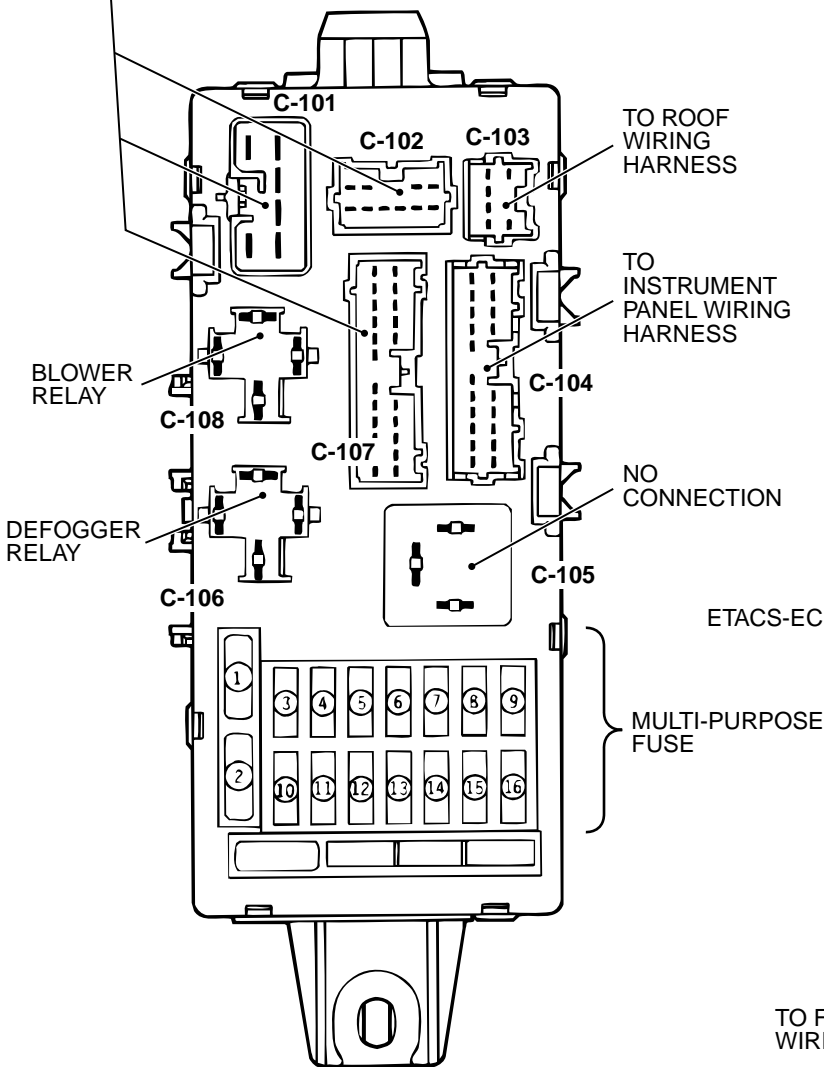

AC000313AD

**TSB Revision**

# JOINT CONNECTOR

NOTE  
IN THE ACTUAL VEHICLE, SOME OF THE JOINT CONNECTOR TERMINALS IN THE SAME BUS ARE USED, SO IN SOME CASES, THE TERMINALS INDICATED ON THE CIRCUIT DIAGRAMS DO NOT AGREE WITH THE ONES IN THE ACTUAL VEHICLE.

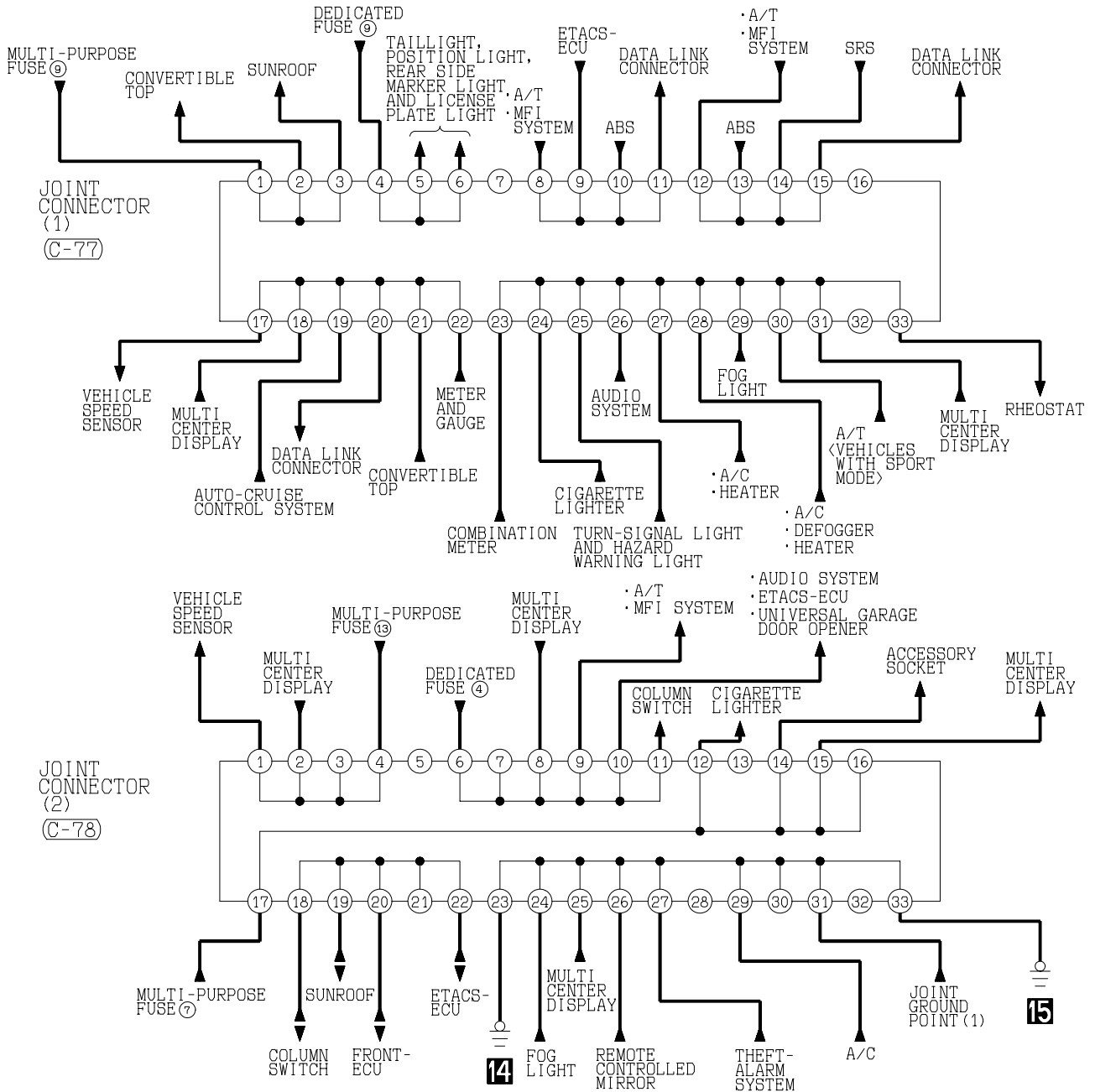

(C-77)

1	2	3	4	5	6	7	8	9	10	11
12	13	14	15	16	17	18	19	20	21	22
23	24	25	26	27	28	29	30	31	32	33

(C-78)

1	2	3	4	5	6	7	8	9	10	11
12	13	14	15	16	17	18	19	20	21	22
23	24	25	26	27	28	29	30	31	32	33

# CENTRALIZED JUNCTION

M1901000300106

## FUSIBLE LINK

NO.	CIRCUIT	HOUSING COLOR	RATED CAPACITY (A)
1	Generator circuit	White	120
2	Multi-purpose fuse No.1, 2, 3, 10, 11	Yellow	60
3	-	-	-
4	Dedicated fuse No.15, 17, power windows, power seat, convertible top and audio system <Vehicles with amplifier>	Pink	30
5	Air conditioning system and cooling system	Red	50
6	Anti-lock braking system	Red	50
7	Convertible top circuit	Pink	30
8	Ignition switch circuit	Pink	30

(CONNECTED DIRECTLY TO BATTERY POSITIVE TERMINAL)

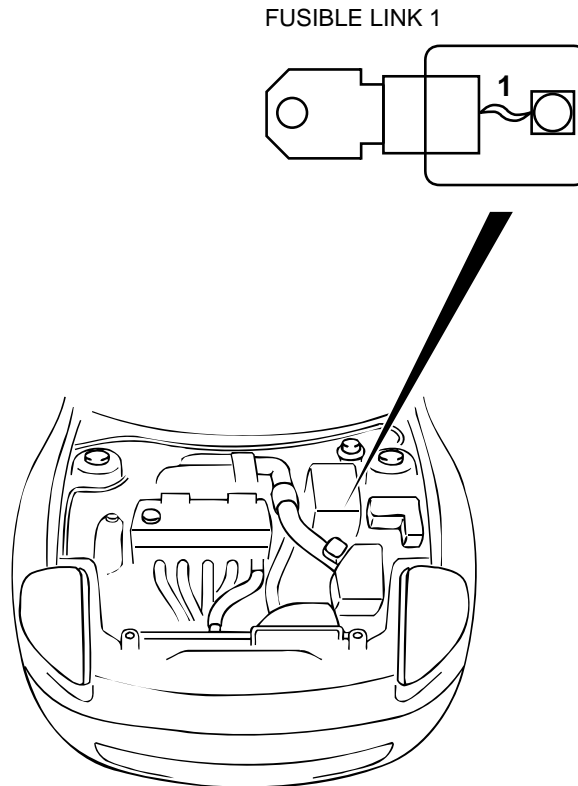

AC004954AB

TSB Revision

(RELAY BOX IN ENGINE COMPARTMENT)

FUSIBLE LINKS 2 TO 8

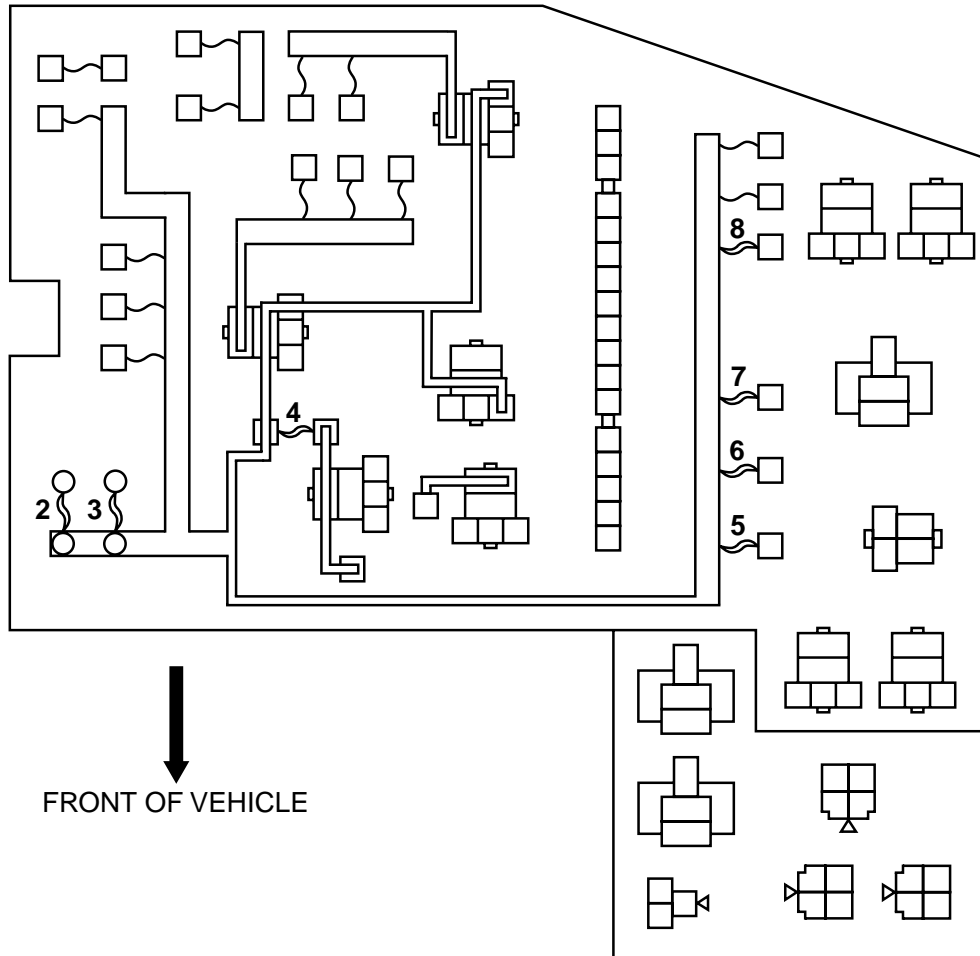

FRONT OF VEHICLE

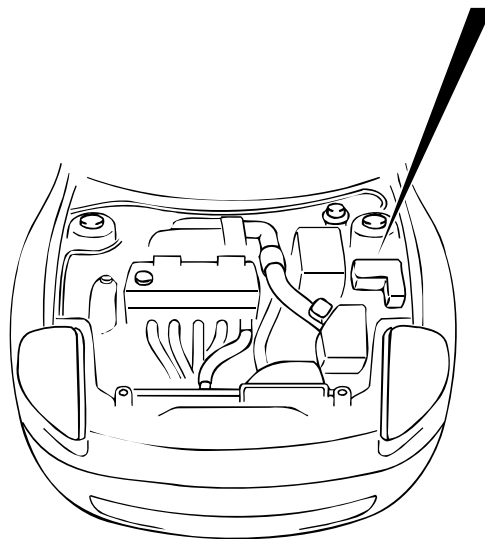

AC004955AB

TSB Revision

**DEDICATED FUSE**

<b>POWER SUPPLY CIRCUIT</b>	<b>NO.</b>	<b>RATED CAPACITY (A)</b>	<b>HOUSING COLOR</b>	<b>CIRCUIT</b>
Battery	1	–	–	–
	2	15	Blue	Fog light
	3	10	Red	Air conditioning system
	4	10	Red	ECU power supply, dome light, trunk light, universal garage door opener, sunroof assembly, luggage compartment light, audio system, multi-center display, meter and gauge
Ignition switch (ACC)	5	10	Red	Audio system
Headlight (High)	6	10	Red	Headlight and theft-alarm system
	7	10	Red	Headlight and theft-alarm system
Taillight relay	8	10	Red	Rheostat, taillight, position light, rear side marker light and illumination circuit
	9	10	Red	Taillight, position light, rear side marker light and license plate light
	10	–	–	–
Headlight relay (Low)	11	10	Red	Headlight
	12	10	Red	Headlight
Battery	13	20	Yellow	INVECS-II 4A/T, MFI system, air conditioning system, cooling system and immobilizer system
	14	10	Red	Charging system, central door locking system <Vehicles with keyless entry system>, turn-signal light and hazard warning light
Fusible link No.4	15	20	Yellow	Audio system <Vehicles with amplifier>
–	16	–	–	–
Fusible link No.4	17	20	Yellow	Sunroof <ECLIPSE>
Ignition switch (ACC)	18	20	Yellow	Windshield wiper and washer

(RELAY BOX IN ENGINE COMPARTMENT)

DEDICATED FUSES 1 TO 14

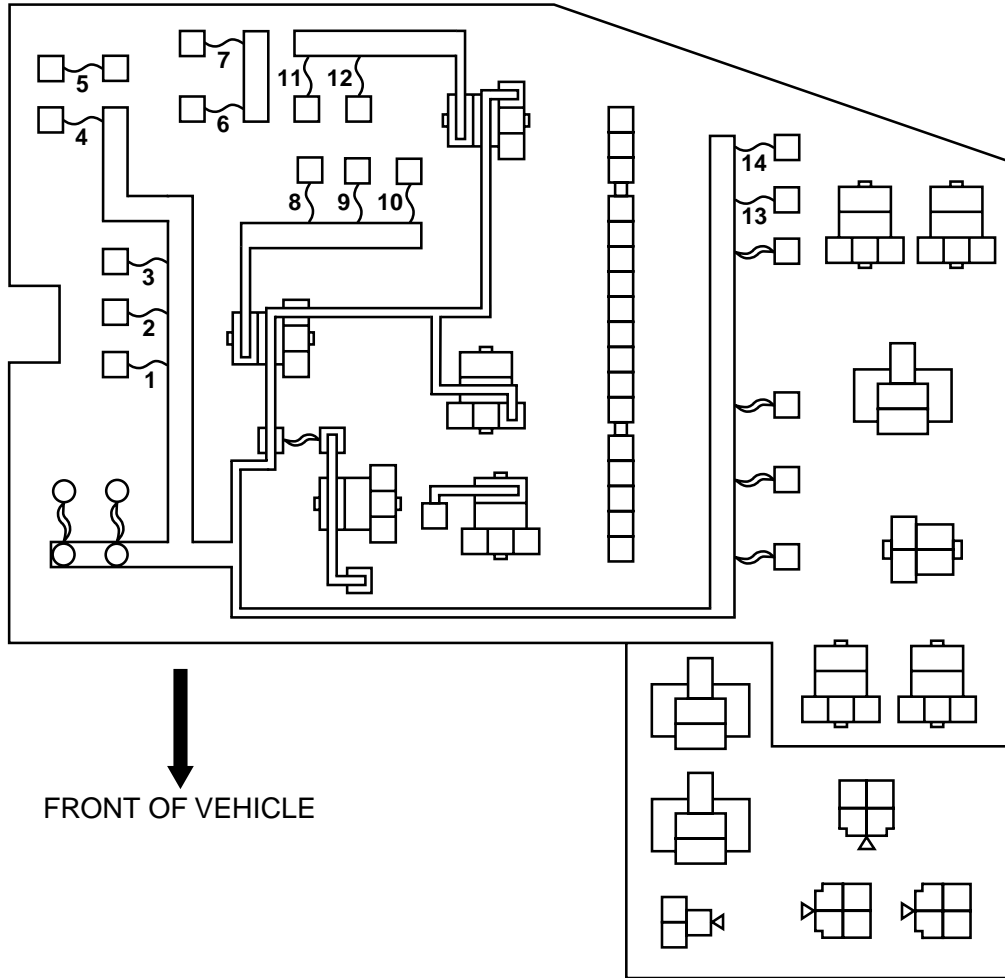

(CONNECTED TO JUNCTION BLOCK)

DEDICATED FUSES 15 TO 18

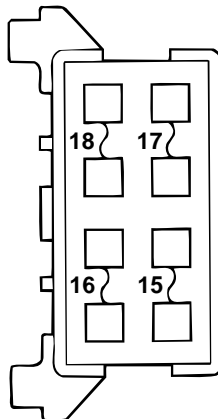

AC000314AB

TSB Revision



**MULTI-PURPOSE FUSE**

<b>POWER SUPPLY CIRCUIT</b>	<b>NO.</b>	<b>RATED CAPACITY (A)</b>	<b>HOUSING COLOR</b>	<b>LOAD CIRCUIT</b>
Battery	1	30	Pink	Defogger and choke coil
	2	30	Pink	Automatic compressor controller, resistor and blower motor
	3	15	Blue	Powertrain control module, ABS-ECU, stoplight, auto-cruise control-ECU and immobilizer-ECU
Ignition switch (IG1)	4	–	–	–
	5	10	Red	Powertrain control module, input shaft speed sensor, output shaft speed sensor, backup light, SRS-ECU, and ETACS-ECU
Ignition switch (ACC)	6	–	–	–
	7	15	Blue	Cigarette lighter, accessory socket, remote controlled mirror and multi center display unit
	8	20	Yellow	ETACS-ECU and dedicated fuse NO.18
Ignition switch (IG2)	9	10	Red	Convertible top control module and ABS-ECU
Battery	10	10	Red	Horn, horn relay, theft-alarm horn and theft-alarm horn relay
	11	15	Blue	Data link connector, ETACS-ECU and combination meter
Ignition switch (IG1)	12	10	Red	Motor antenna assembly <ECLIPSE SPYDER>
	13	10	Red	Combination meter, ETACS-ECU, SRS-ECU, auto-cruise control-ECU, column-ECU, multi center display unit and vehicle speed sensor
Ignition switch (ACC)	14	–	–	–
Ignition switch (IG2)	15	–	–	–
	16	10	Red	Blower relay, outside/inside air selection damper control motor, defogger relay, A/C switch, front-ECU, A/C compressor relay and automatic compressor controller

(IN JUNCTION BLOCK)

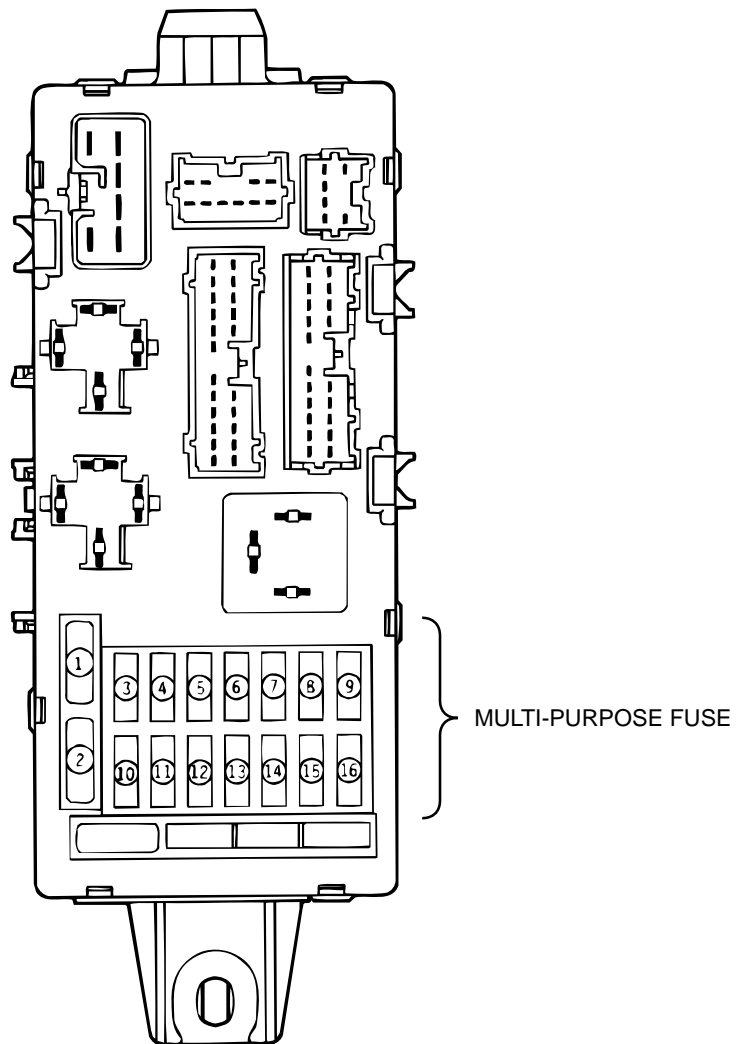

AC000315AB

**CENTRALIZED RELAY**

CONNECTOR NO.	NAME	CONNECTOR NO.	NAME
A-04X	Power window relay	A-13X	Fan control relay
A-05X	Taillight relay	A-14X	A/C compressor relay
A-06X	Fog light relay	A-15X	Horn relay
A-07X	Headlight relay (High)	A-16X	Inspection connector
A-08X	Headlight relay (Low)	A-17X	–
A-09X	Front-ECU	A-18X	Starter relay <M/T>
A-10X	–	A-19X	A/T control relay
A-11X	Theft-alarm horn relay	A-20X	Fuel pump relay
A-12X	–	A-21X	MFI relay

(RELAY BOX IN ENGINE COMPARTMENT)

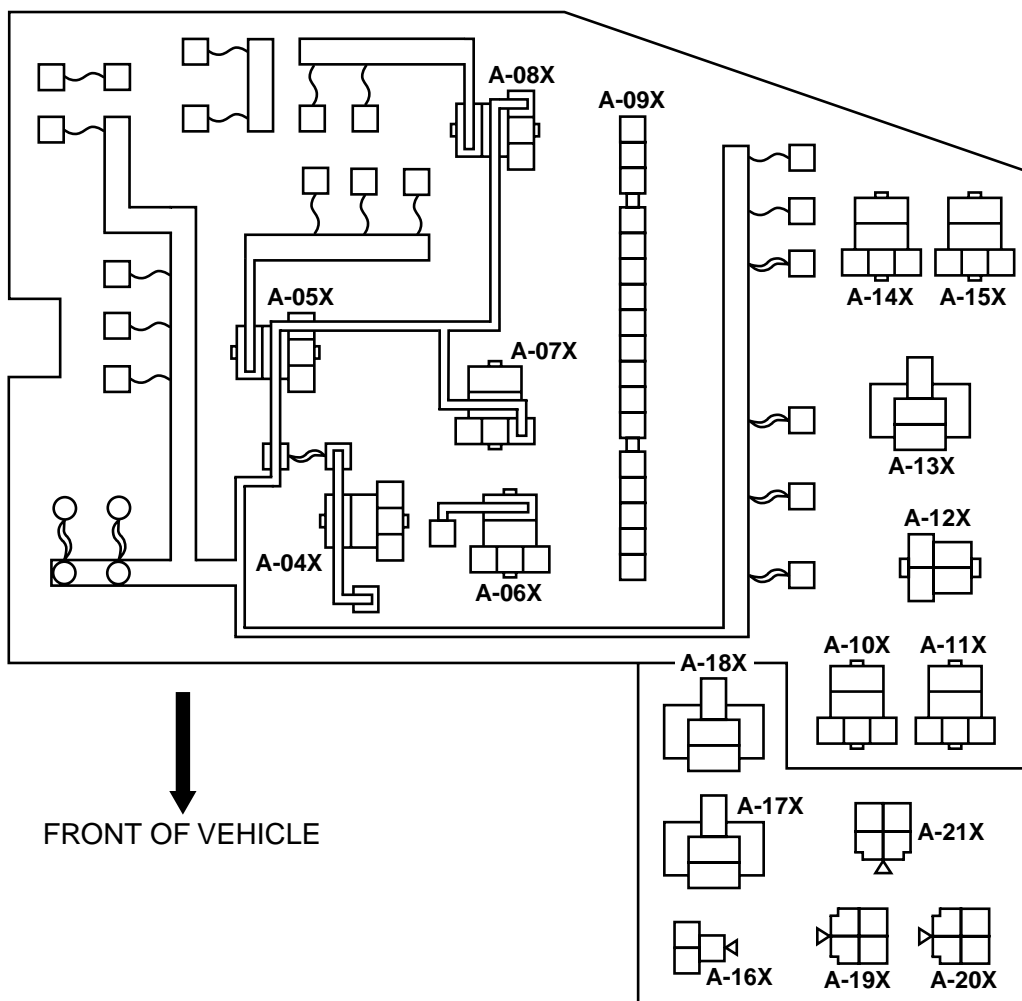

AC000312AC

TSB Revision

POWER DISTRIBUTION SYSTEM

M1901000400073

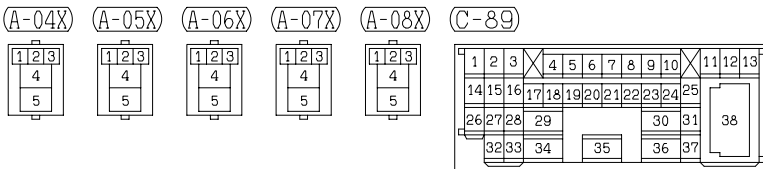
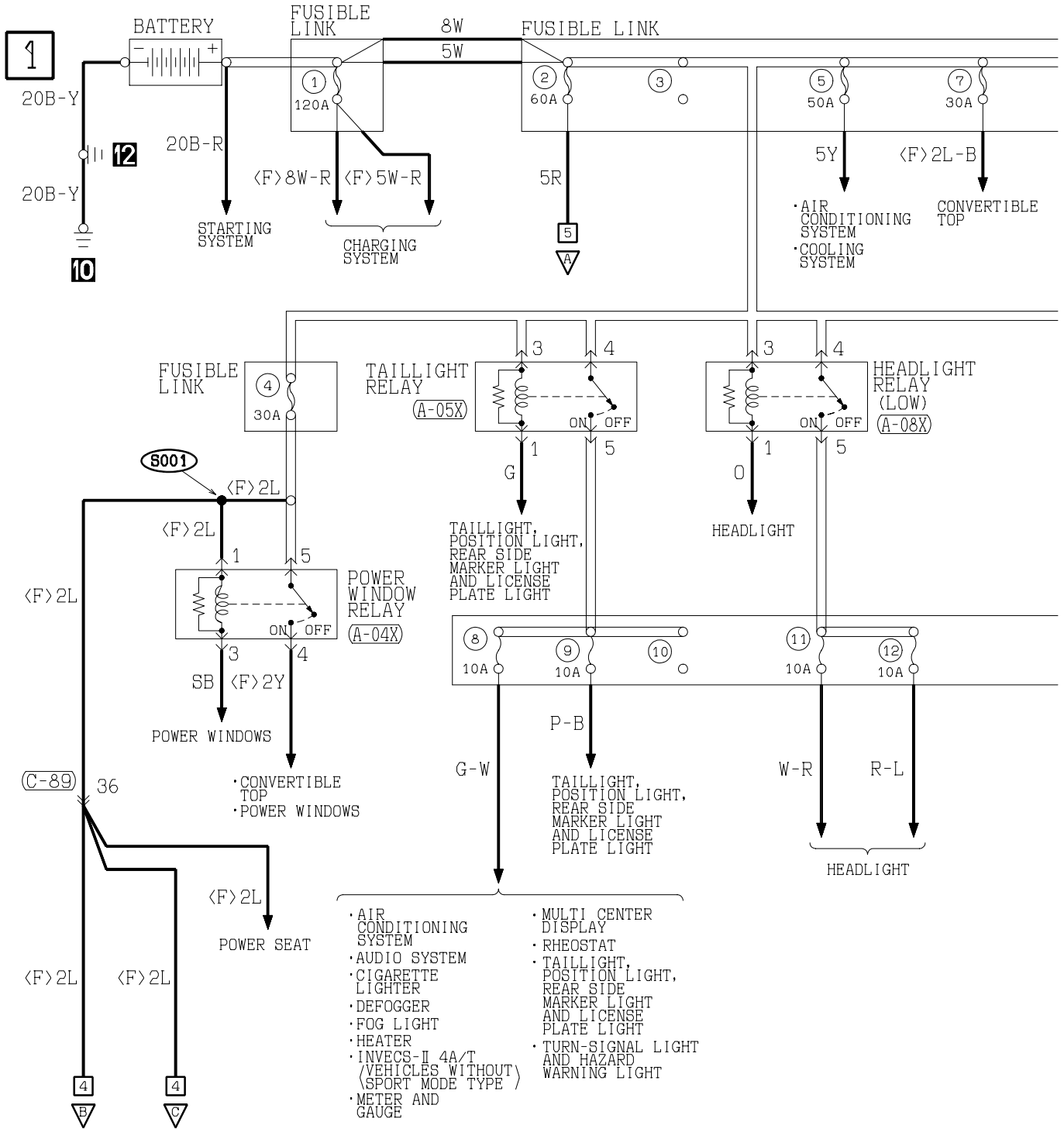

H1S01M02AA

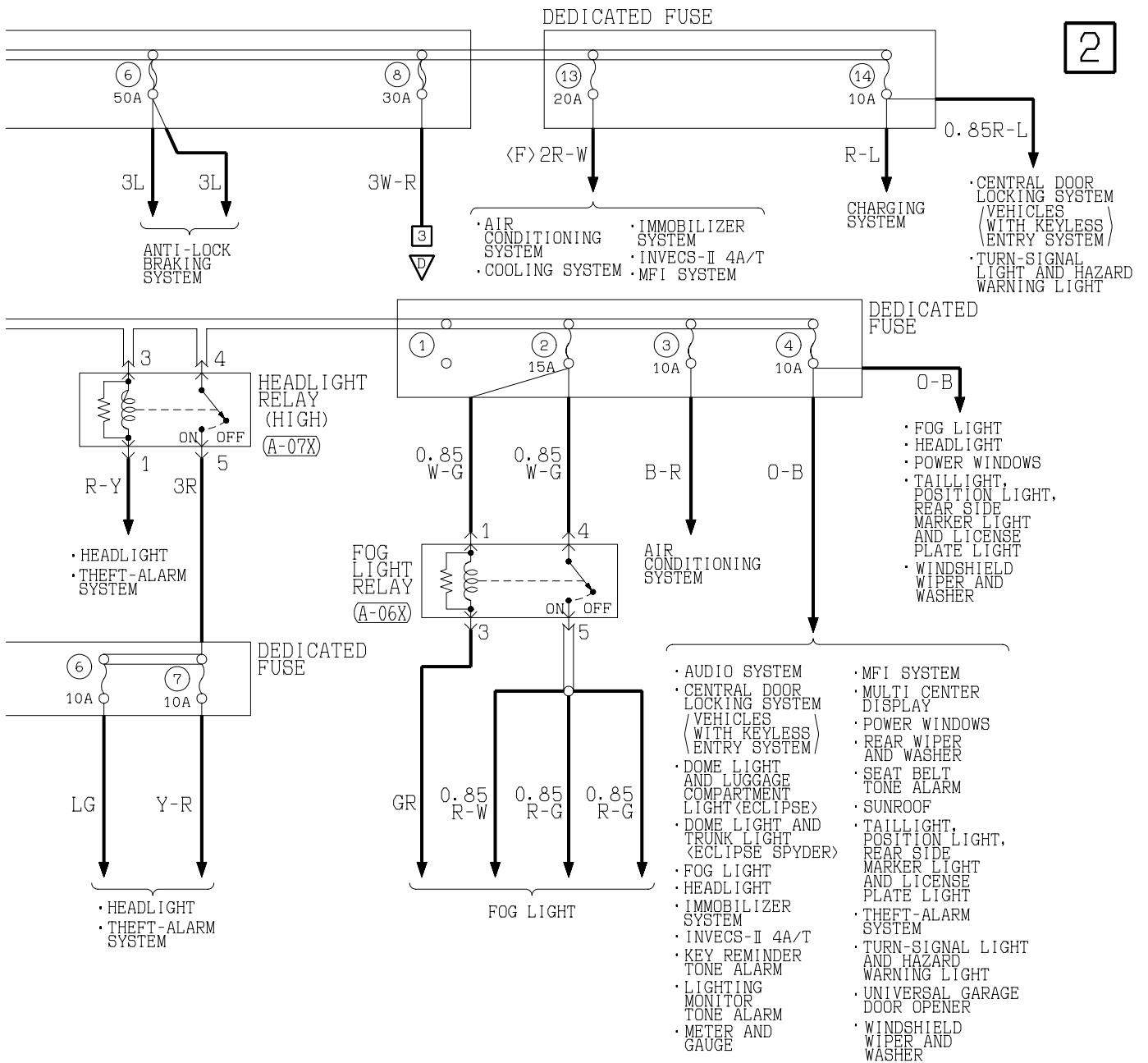

WIRE COLOR CODE  
 B : BLACK BR : BROWN G : GREEN GR : GRAY L : BLUE LG : LIGHT GREEN O : ORANGE  
 P : PINK R : RED SB : SKY BLUE V : VIOLET W : WHITE Y : YELLOW

H1S01M02AB

**TSB Revision**



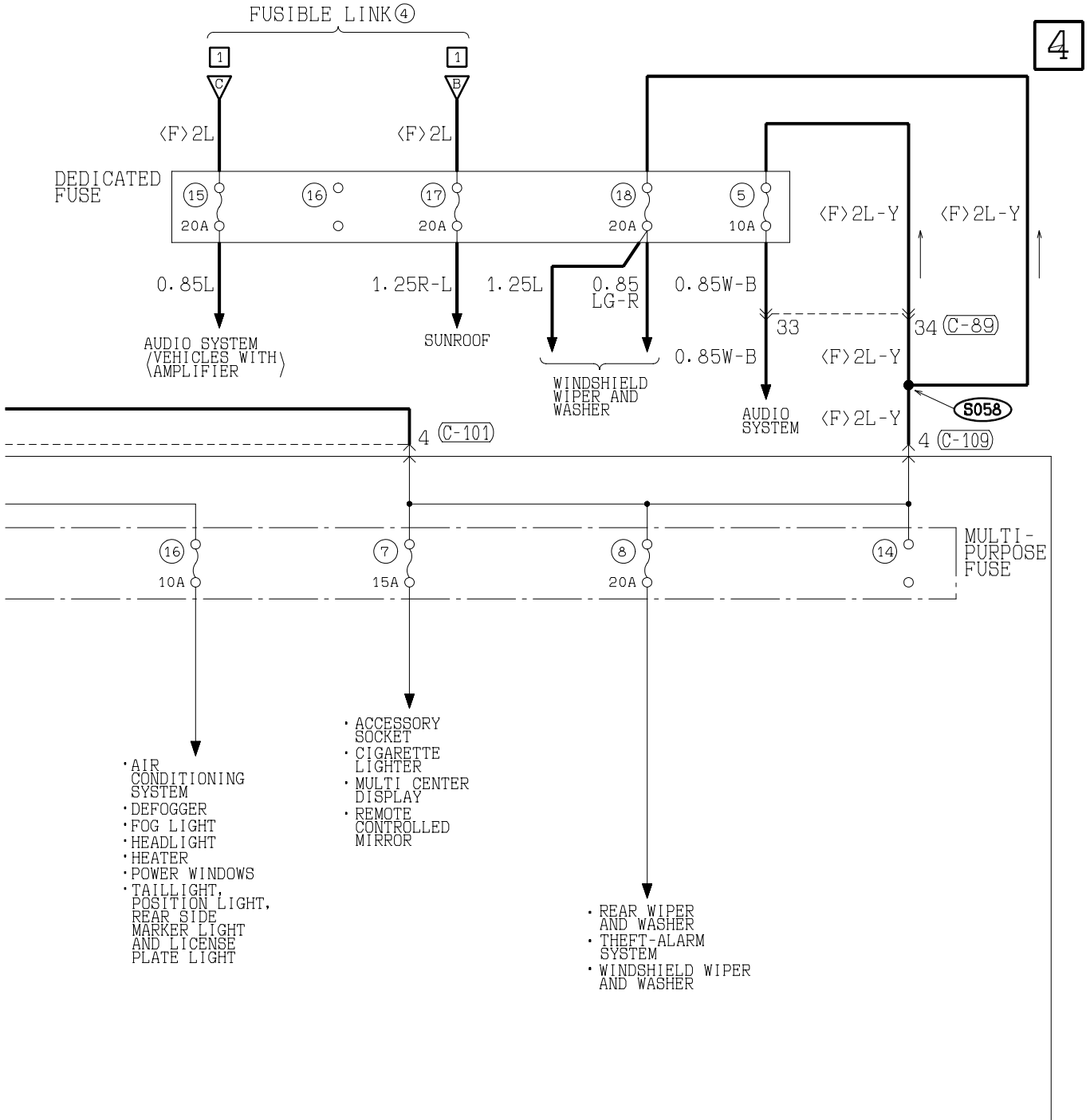

WIRE COLOR CODE  
 B : BLACK    BR : BROWN    G : GREEN    GR : GRAY    L : BLUE    LG : LIGHT GREEN    O : ORANGE  
 P : PINK    R : RED    SB : SKY BLUE    V : VIOLET    W : WHITE    Y : YELLOW

H1S01M02BB

**TSB Revision**

POWER DISTRIBUTION SYSTEM (CONTINUED)

5

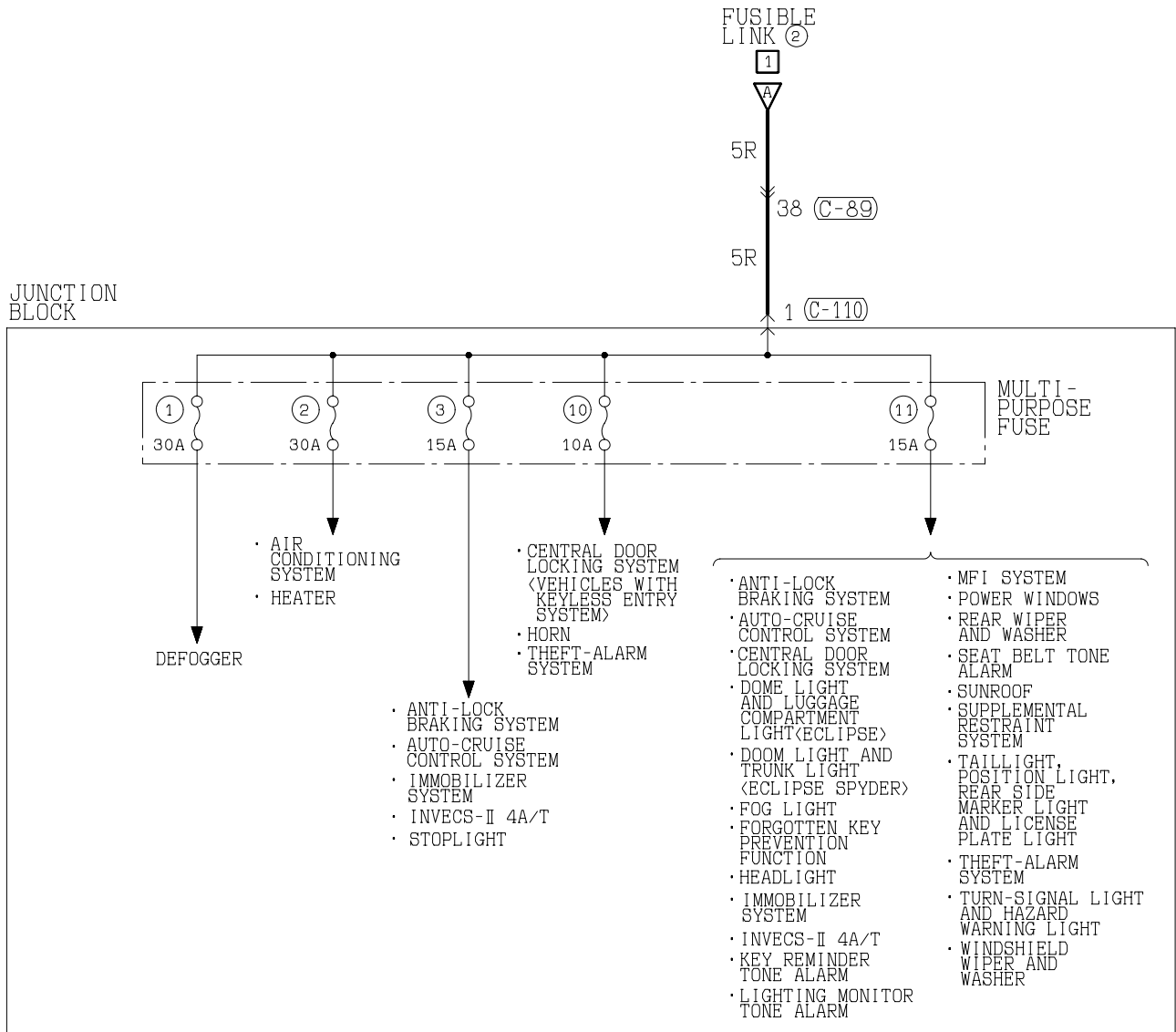

(C-89)

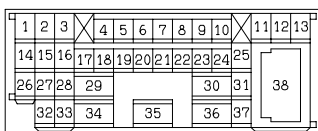

(C-110)



WIRE COLOR CODE

B : BLACK BR: BROWN G : GREEN GR: GRAY  
 L : BLUE LG: LIGHT GREEN O : ORANGE P : PINK  
 R : RED SB: SKY BLUE V : VIOLET W : WHITE  
 Y : YELLOW

TSB Revision



NOTES

TSB Revision

# STARTING SYSTEM <M/T>

1

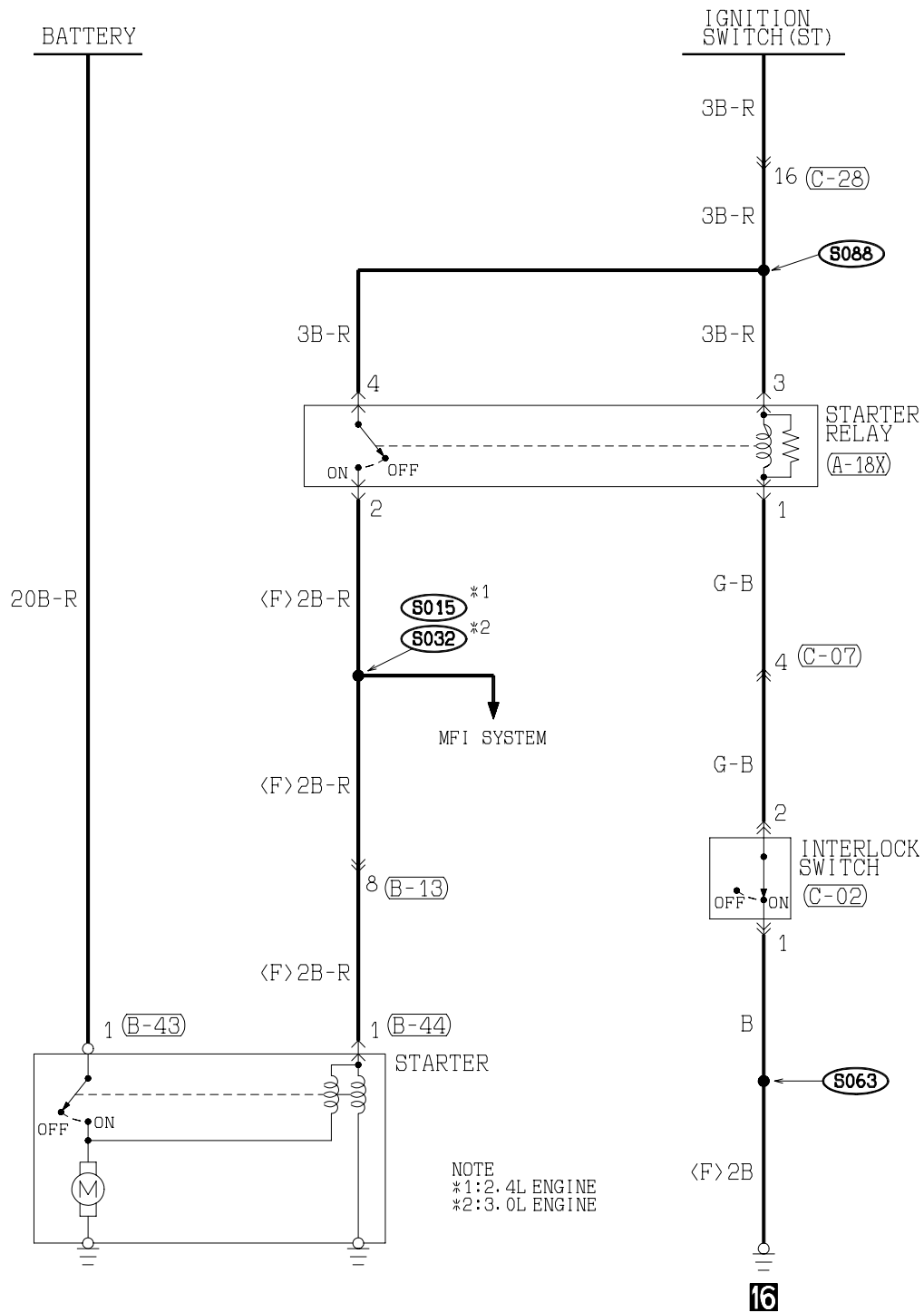

16

(A-18X)

(B-13) MU802749

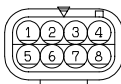

(B-43)

(B-44)

(C-02)

(C-07) MU801333

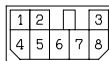

(C-28)

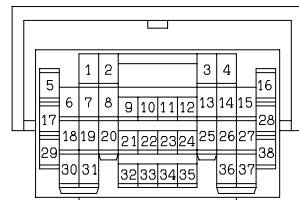

WIRE COLOR CODE

B : BLACK LG: LIGHT GREEN G : GREEN L : BLUE  
 BR: BROWN O : ORANGE GR: GRAY R : RED  
 W : WHITE SB: SKY BLUE P : PINK Y : YELLOW  
 V : VIOLET

TSB Revision

STARTING SYSTEM <A/T>

1

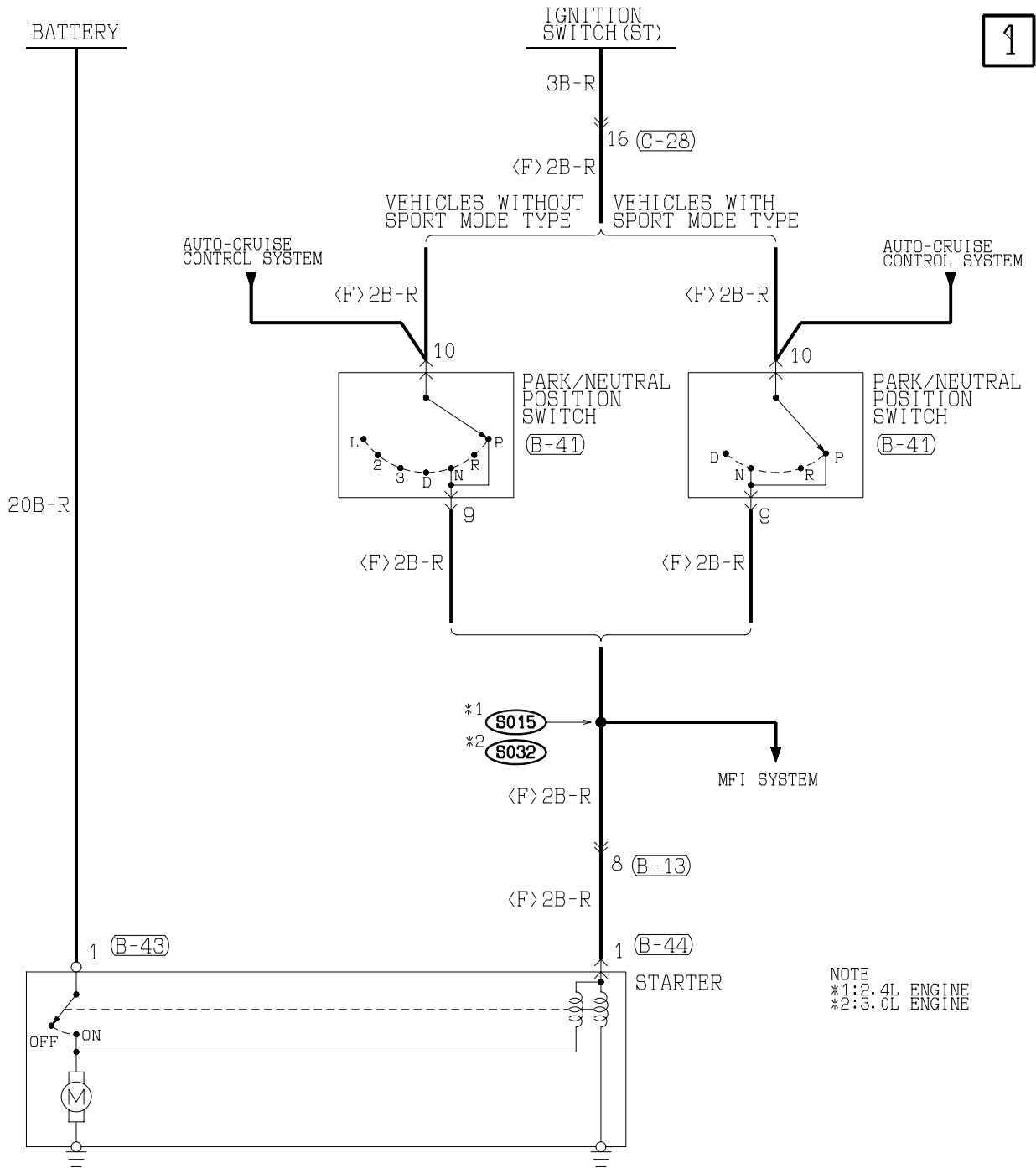

NOTE  
\*1: 2.4L ENGINE  
\*2: 3.0L ENGINE

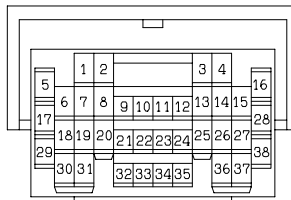
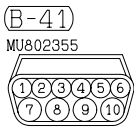
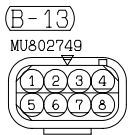

WIRE COLOR CODE

- B : BLACK
- G : GREEN
- L : BLUE
- O : ORANGE
- R : RED
- V : VIOLET
- Y : YELLOW
- BR : BROWN
- GR : GRAY
- LG : LIGHT GREEN
- P : PINK
- SB : SKY BLUE
- W : WHITE

H1502M04AA

TSB Revision

IGNITION SYSTEM <2.4L ENGINE-M/T>

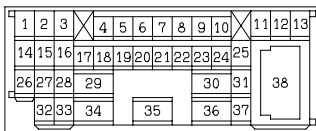
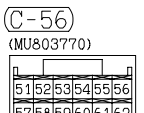
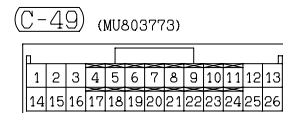
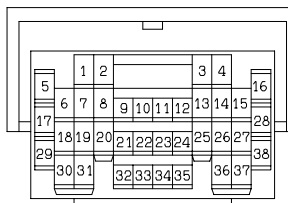
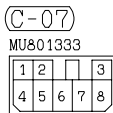
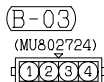
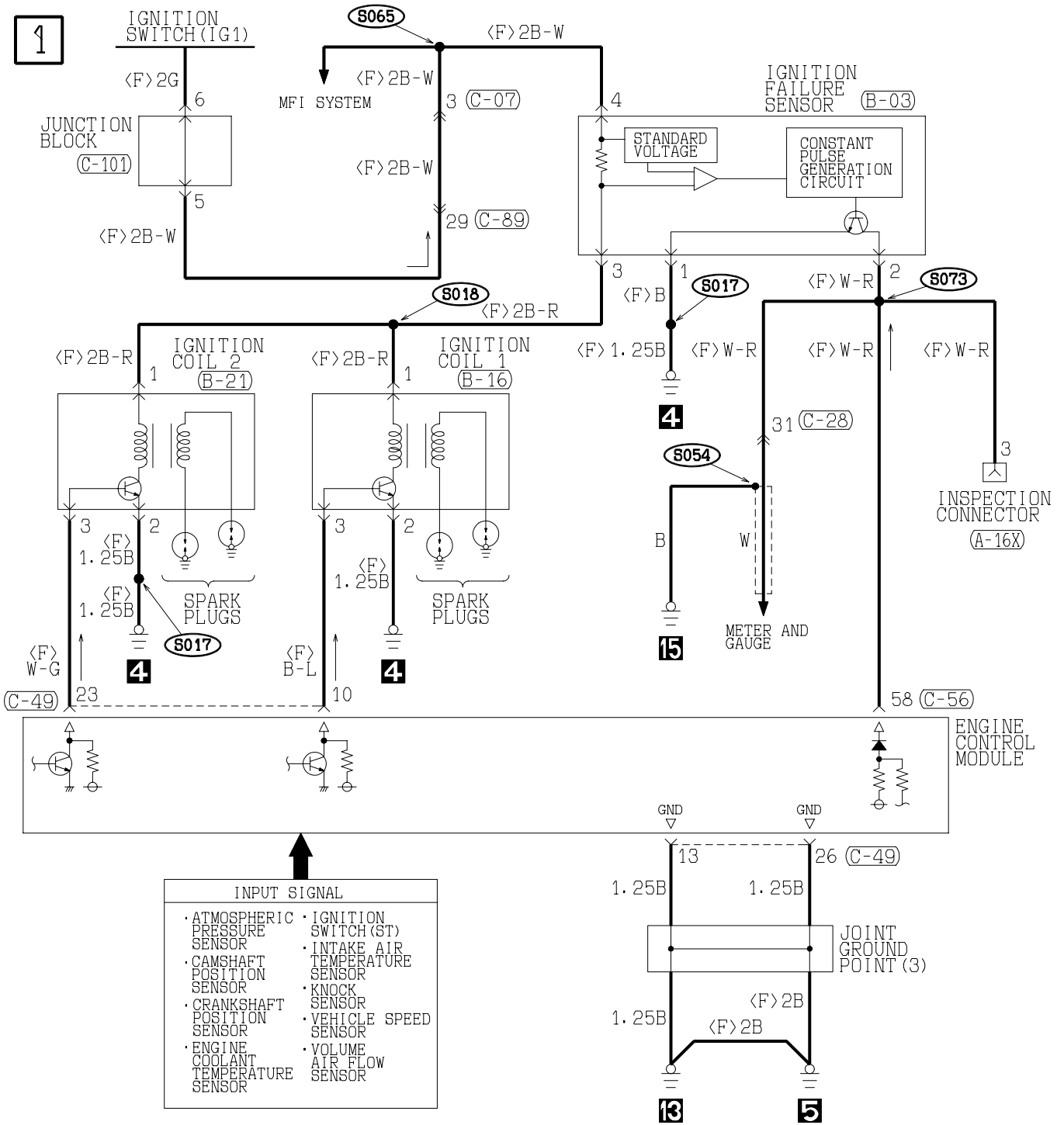

IGNITION SYSTEM <2.4L ENGINE-A/T>

M1901000600130

1

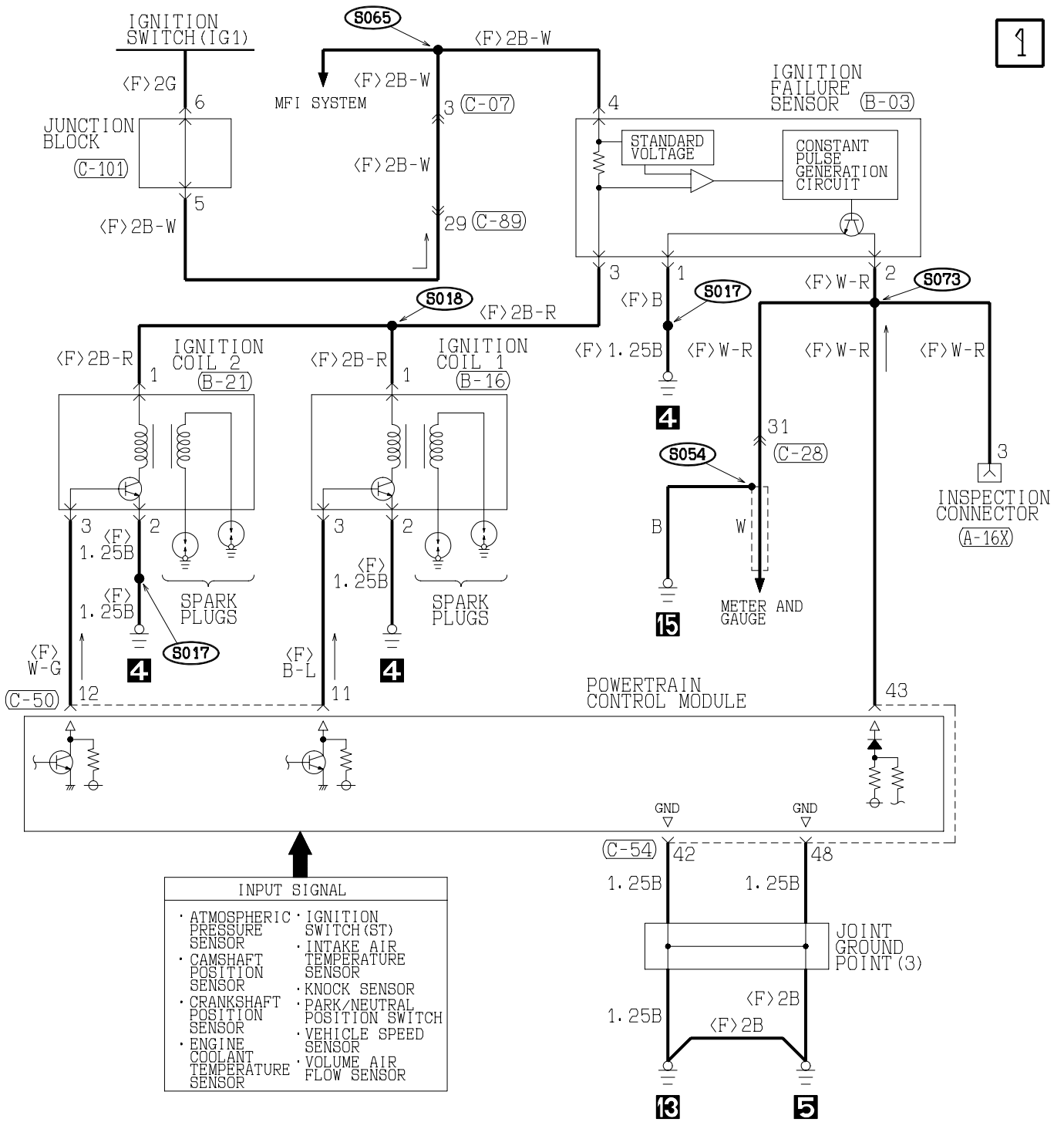

- INPUT SIGNAL
- ATMOSPHERIC PRESSURE SENSOR
  - CAMSHAFT POSITION SENSOR
  - CRANKSHAFT POSITION SENSOR
  - ENGINE COOLANT TEMPERATURE SENSOR
  - IGNITION SWITCH (ST)
  - INTAKE AIR TEMPERATURE SENSOR
  - KNOCK SENSOR
  - PARK/NEUTRAL POSITION SWITCH
  - VEHICLE SPEED SENSOR
  - VOLUME AIR FLOW SENSOR

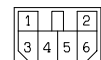
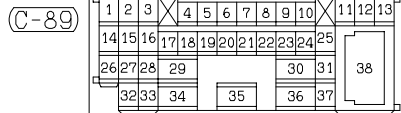
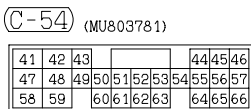
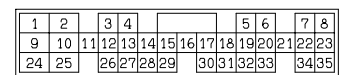
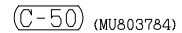
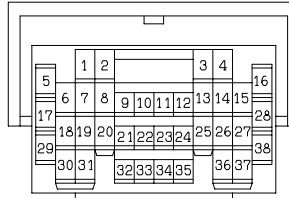
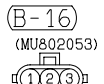
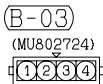

H1503M07AA

TSB Revision

# IGNITION SYSTEM <3.0L ENGINE-M/T>

1

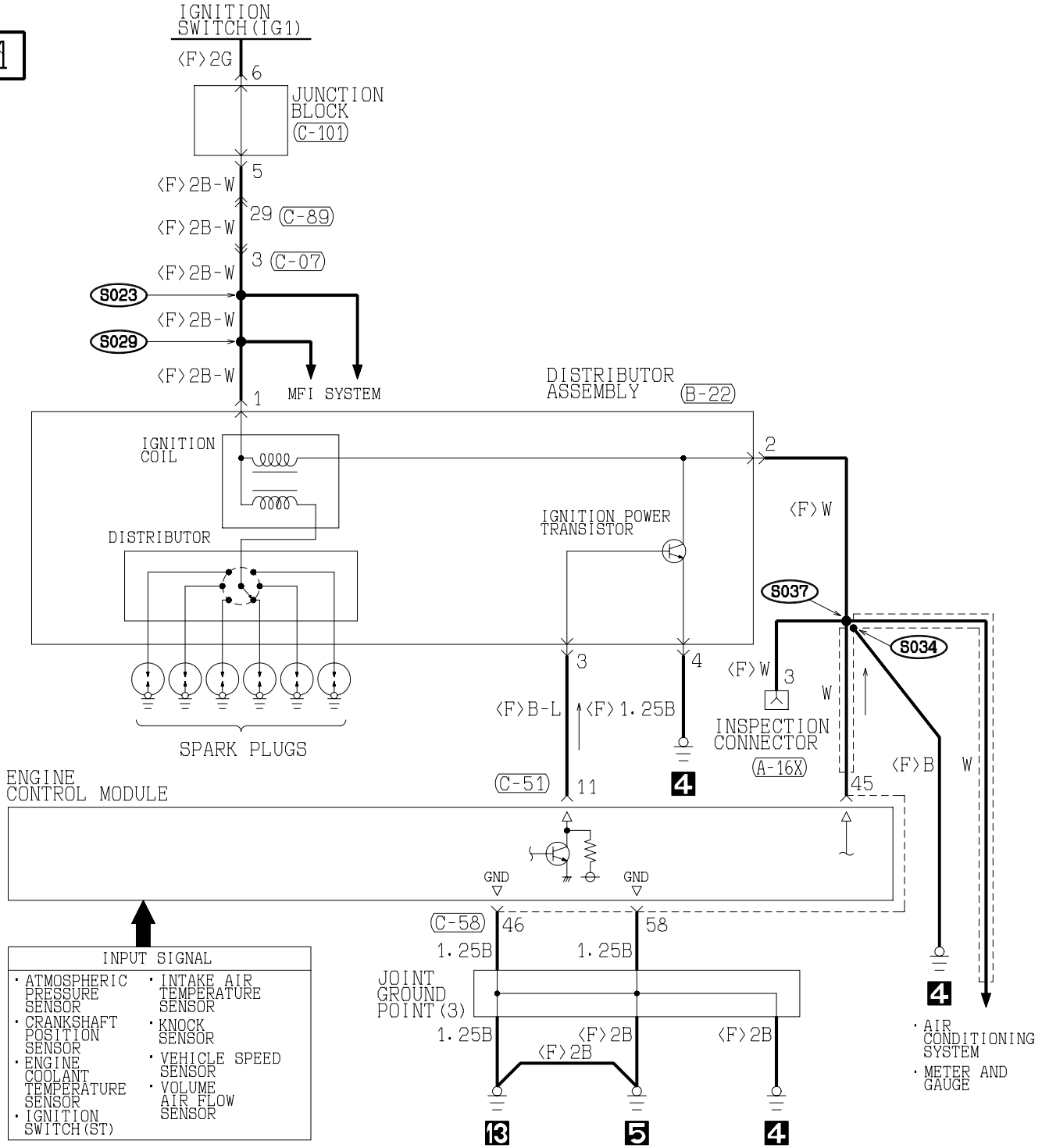

(A-16X)

(B-22)

(C-07)

(C-51) (MU803784)

(C-58) (MU803782)

(C-89)

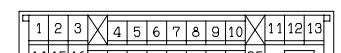
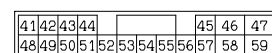
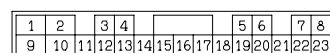
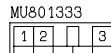
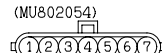

WIRE COLOR CODE  
 B : BLACK  
 L : BLUE  
 R : RED  
 Y : YELLOW

BR : BROWN  
 LG : LIGHT GREEN  
 SB : SKY BLUE

G : GREEN  
 O : ORANGE  
 V : VIOLET

GR : GRAY  
 P : PINK  
 W : WHITE

IGNITION SYSTEM <3.0L ENGINE-A/T>

M1901000600152

1

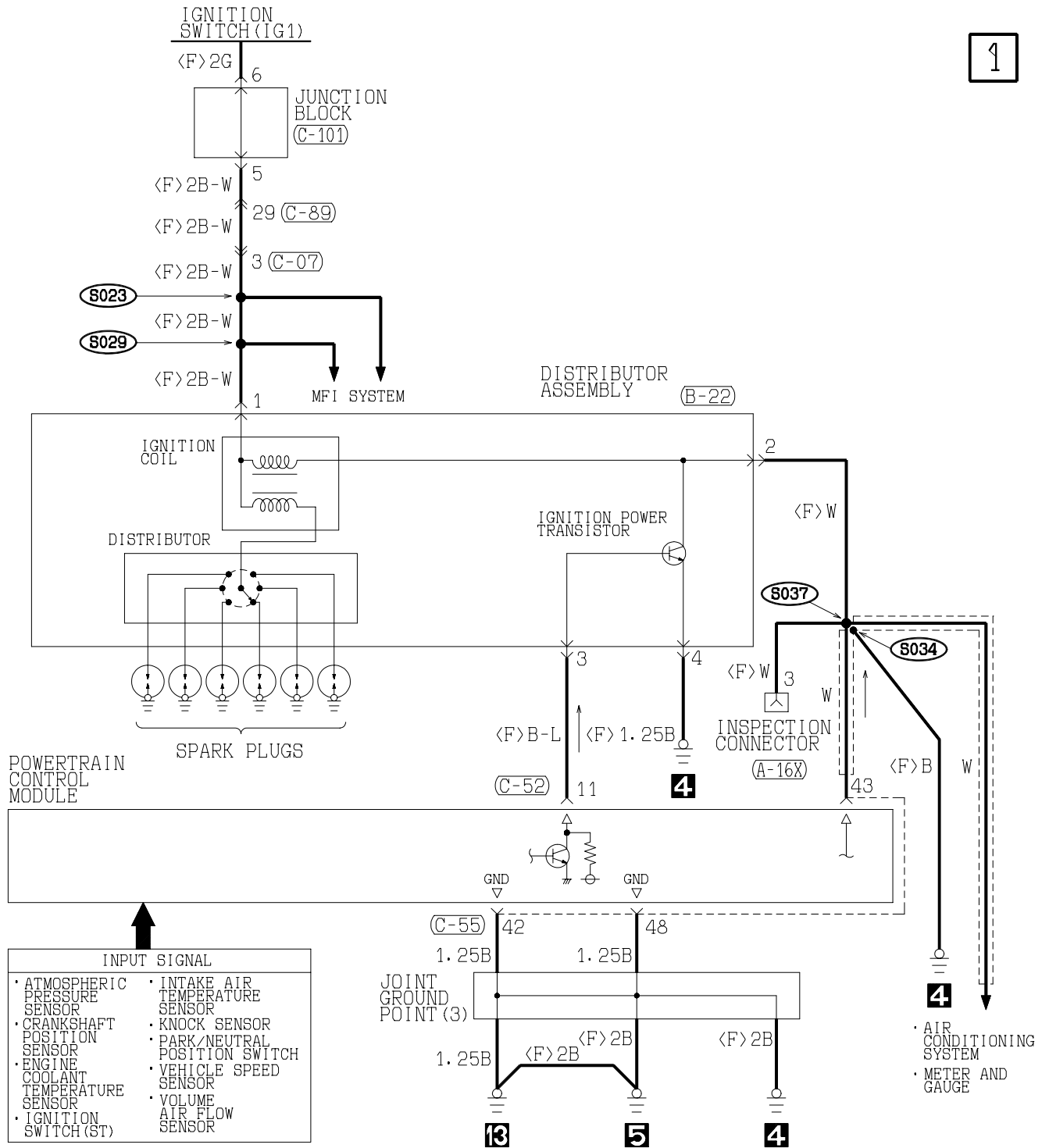

- INPUT SIGNAL
- ATMOSPHERIC PRESSURE SENSOR
  - CRANKSHAFT POSITION SENSOR
  - ENGINE COOLANT TEMPERATURE SENSOR
  - IGNITION SWITCH (ST)
  - INTAKE AIR TEMPERATURE SENSOR
  - KNOCK SENSOR
  - PARK/NEUTRAL POSITION SWITCH
  - VEHICLE SPEED SENSOR
  - VOLUME AIR FLOW SENSOR

(A-16X)



(B-22)

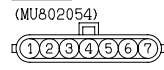

(C-07)

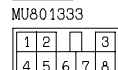

(C-52) (MU803784)

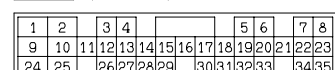

(C-55) (MU803781)

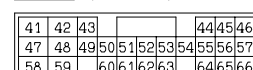

(C-89)

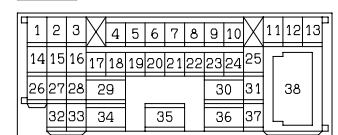

(C-101)  
MU801331



WIRE COLOR CODE

- B : BLACK
- BR : BROWN
- W : WHITE
- V : VIOLET
- LG : LIGHT GREEN
- O : ORANGE
- SB : SKY BLUE
- G : GREEN
- GR : GRAY
- P : PINK
- L : BLUE
- R : RED
- Y : YELLOW

H1503M09AA

TSB Revision

CHARGING SYSTEM <M/T>

M1901000700085

1

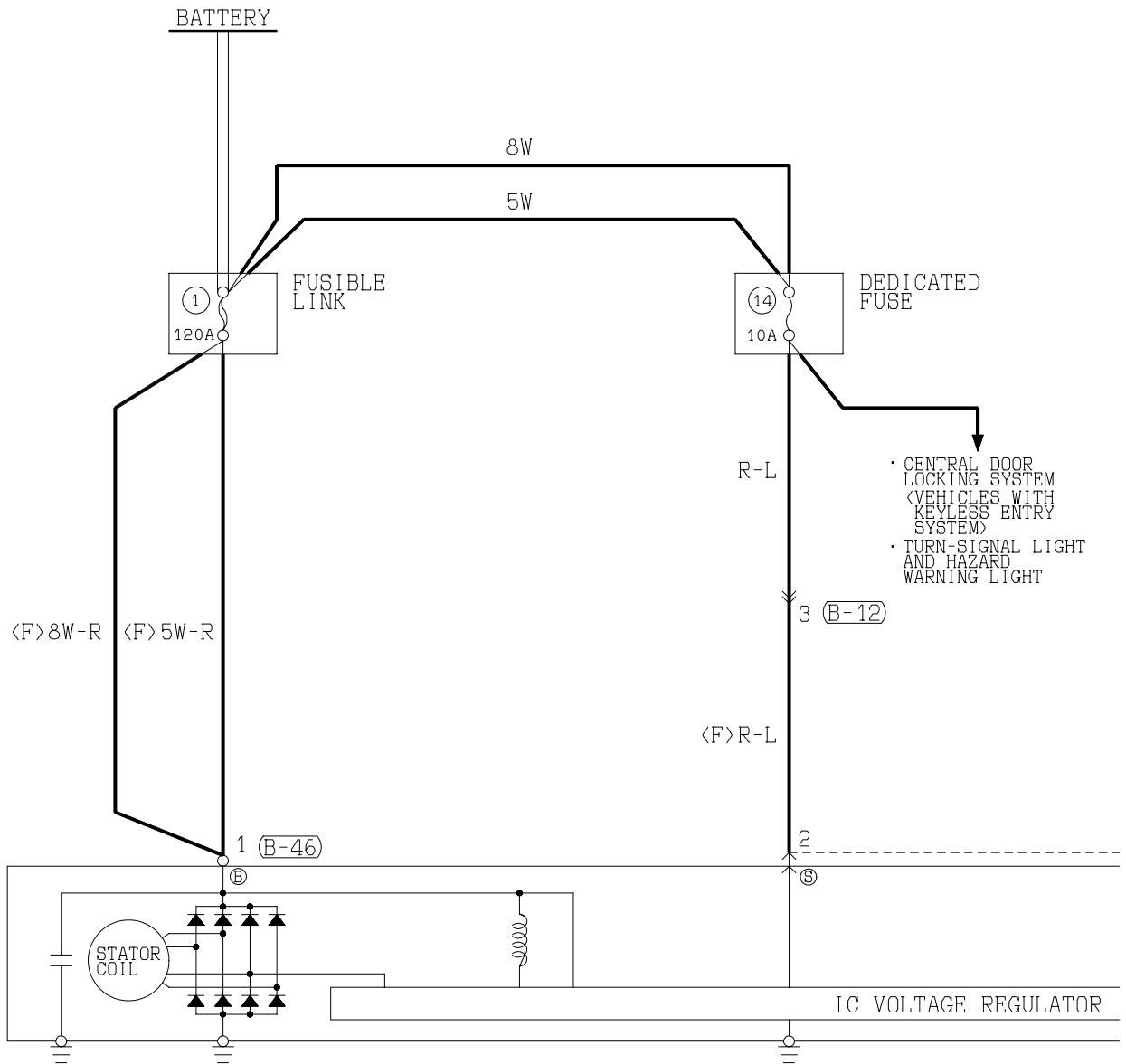

(B-12)  
MU802351



(B-13)  
MU802749

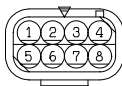

(B-45)  
(MU802046)

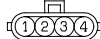

(B-46)



(C-41)

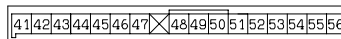

(C-42)

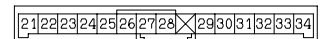

(C-104)  
MU801457

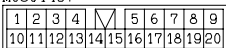

H1804M03AA

TSB Revision



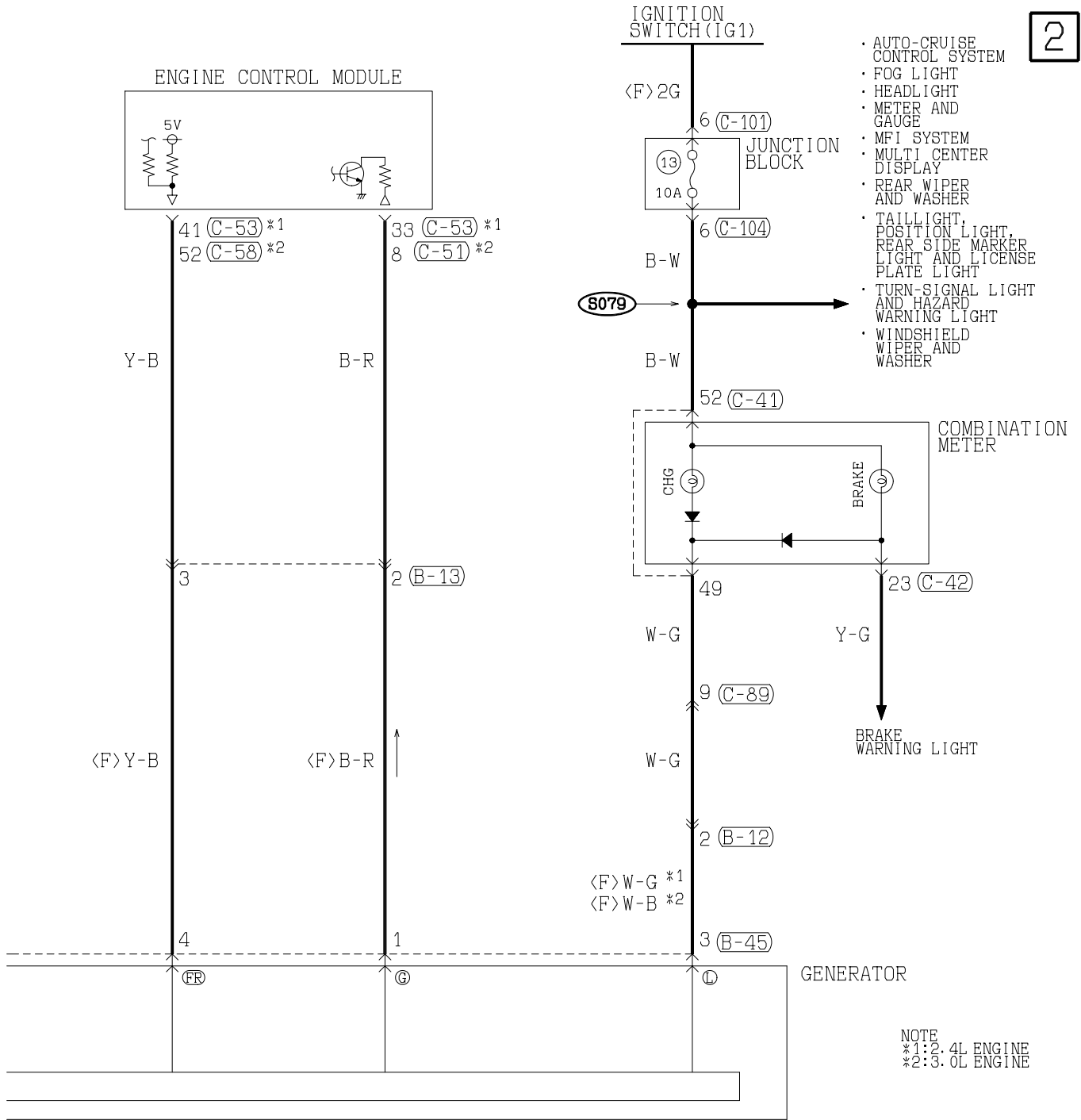

2

- AUTO-CRUISE CONTROL SYSTEM
- FOG LIGHT
- HEADLIGHT
- METER AND GAUGE
- MFI SYSTEM
- MULTI CENTER DISPLAY
- REAR WIPER AND WASHER
- TAILLIGHT, POSITION LIGHT, REAR SIDE MARKER LIGHT AND LICENSE PLATE LIGHT
- TURN-SIGNAL LIGHT AND HAZARD WARNING LIGHT
- WINDSHIELD WIPER AND WASHER

(C-51) (MU803784)

1	2	3	4	5	6	7	8							
9	10	11	12	13	14	15	16	17	18	19	20	21	22	23
24	25	26	27	28	29	30	31	32	33	34	35			

(C-53) (MU803771)

31	32	33	34	35	36	37	38
39	40	41	42	43	44	45	46

(C-58) (MU803782)

41	42	43	44	45	46	47					
48	49	50	51	52	53	54	55	56	57	58	59
60	61	62	63	64	65	66	67	68			

(C-89)

1	2	3	4	5	6	7	8	9	10	11	12	13
14	15	16	17	18	19	20	21	22	23	24	25	
26	27	28	29	30	31	32	33	34	35	36	37	38

(C-101) MU801331

1	2		
3	4	5	6

WIRE COLOR CODE

B : BLACK  
L : BLUE  
R : RED  
Y : YELLOW

BR : BROWN  
LG : LIGHT GREEN  
SB : SKY BLUE

G : GREEN  
O : ORANGE  
V : VIOLET

GR : GRAY  
P : PINK  
W : WHITE

H1S04M03AB

CHARGING SYSTEM <A/T>

M1901000700096

1

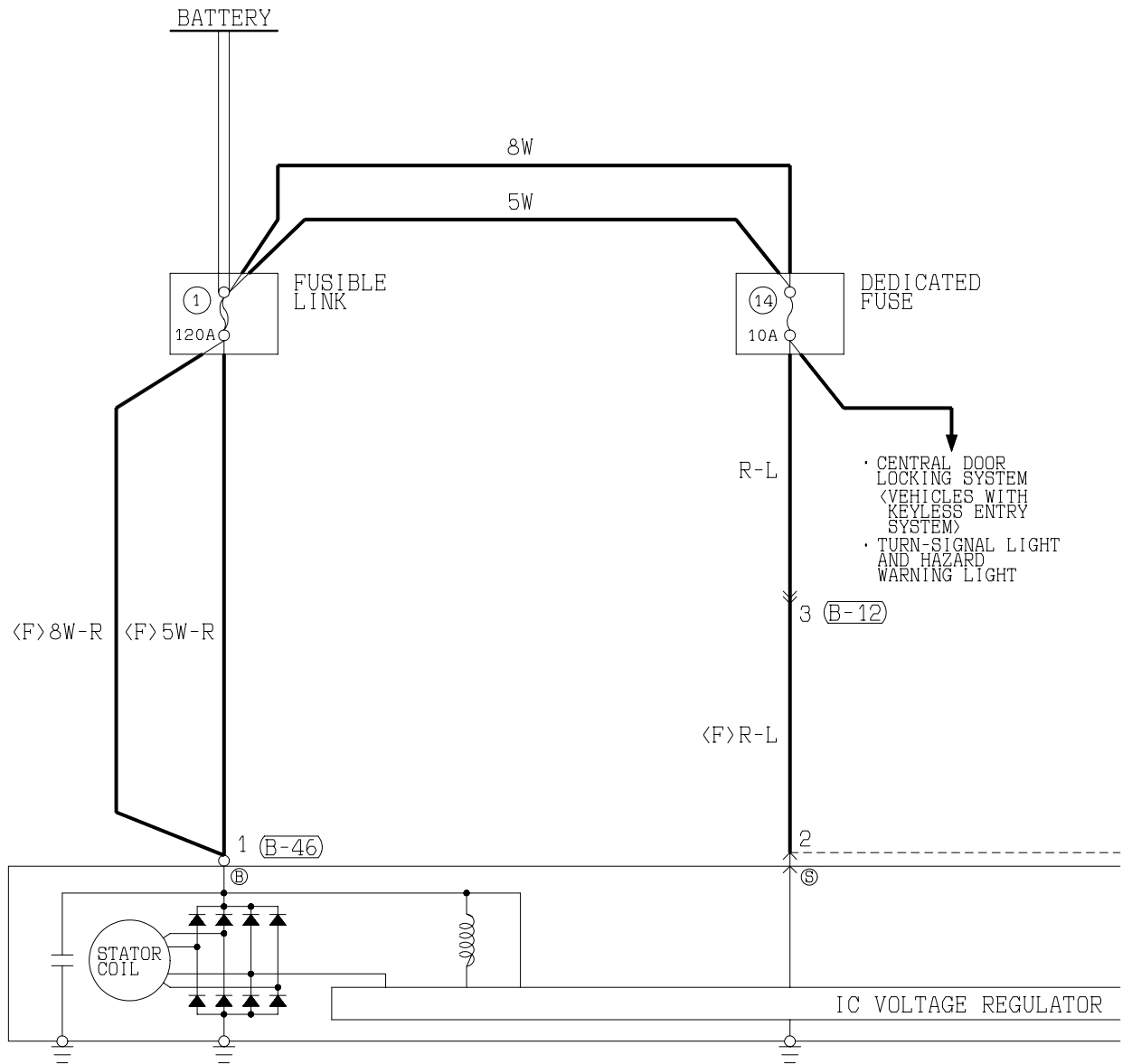

(B-12) MU802351

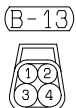

MU802749

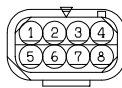

(B-45) (MU802046) (1)(2)(3)(4)

(B-46) (C-41)

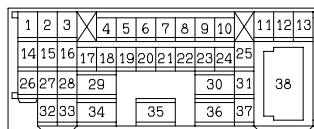

(C-42)

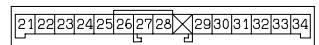

(C-89)

(C-101) MU801331



(C-104)

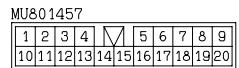

H1804M04AA

TSB Revision

2

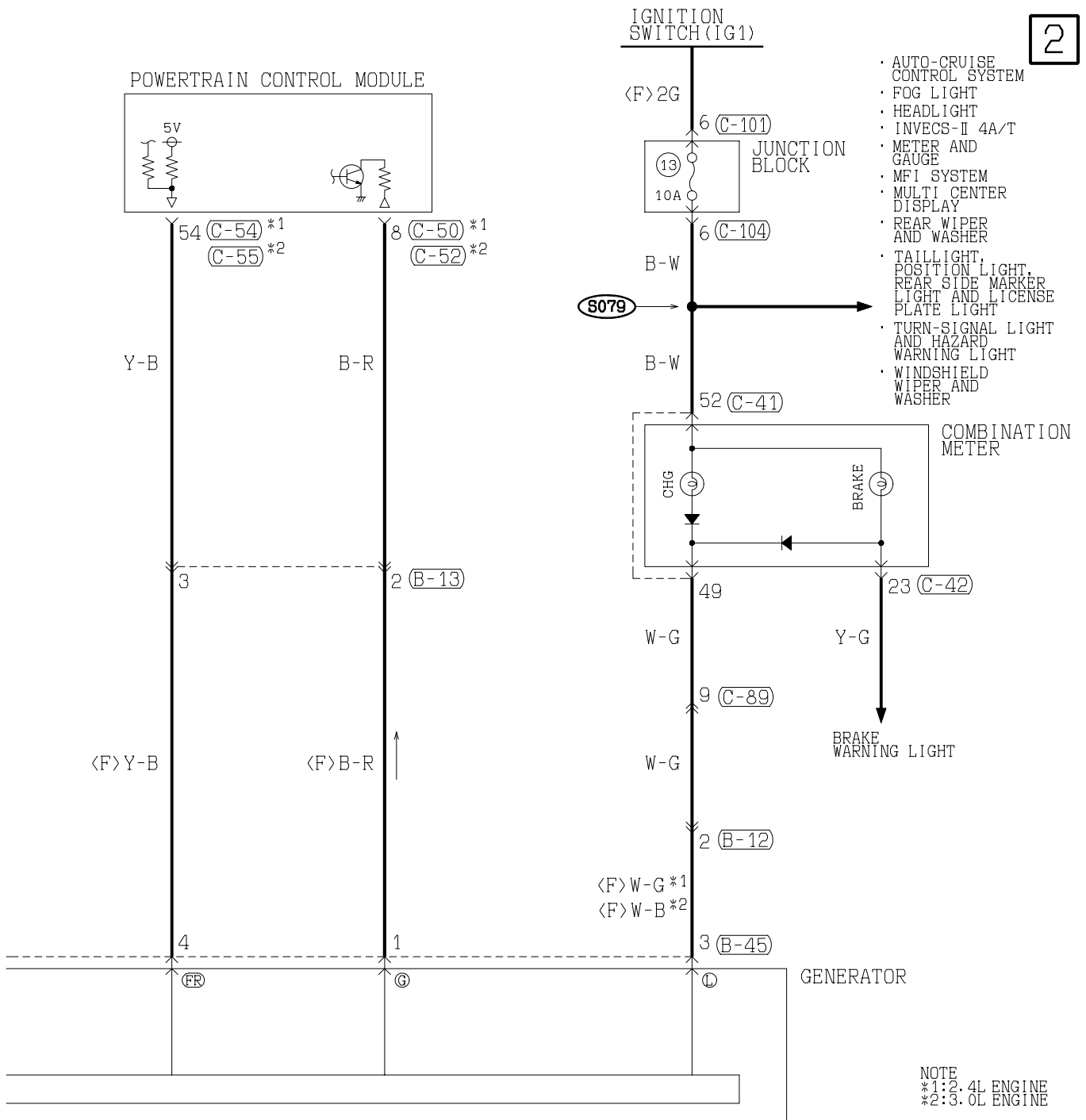

(C-50) (MU803784)

1	2	3	4	5	6	7	8							
9	10	11	12	13	14	15	16	17	18	19	20	21	22	23
24	25	26	27	28	29	30	31	32	33	34	35			

(C-52) (MU803784)

1	2	3	4	5	6	7	8							
9	10	11	12	13	14	15	16	17	18	19	20	21	22	23
24	25	26	27	28	29	30	31	32	33	34	35			

(C-54) (MU803781)

41	42	43	44	45	46					
47	48	49	50	51	52	53	54	55	56	57
58	59	60	61	62	63	64	65	66		

(C-55) (MU803781)

41	42	43	44	45	46					
47	48	49	50	51	52	53	54	55	56	57
58	59	60	61	62	63	64	65	66		

WIRE COLOR CODE  
B : BLACK BR : BROWN  
P : PINK R : RED

G : GREEN GR : GRAY  
SB : SKY BLUE V : VIOLET

L : BLUE LG : LIGHT GREEN O : ORANGE  
W : WHITE Y : YELLOW

H1S04M04AB

TSB Revision

# MFI SYSTEM <2.4L ENGINE-M/T>

M1901000800112

1

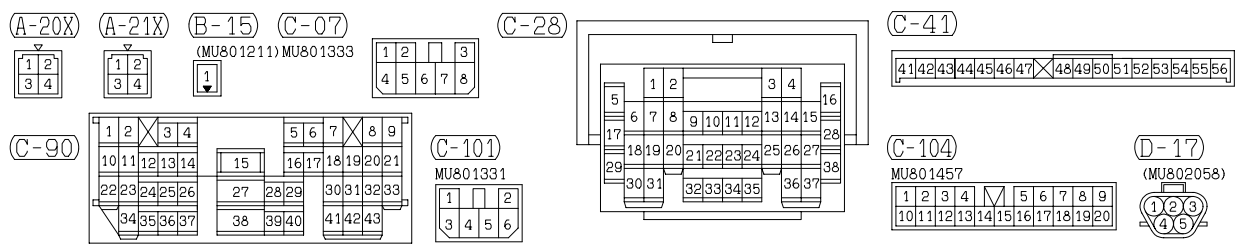
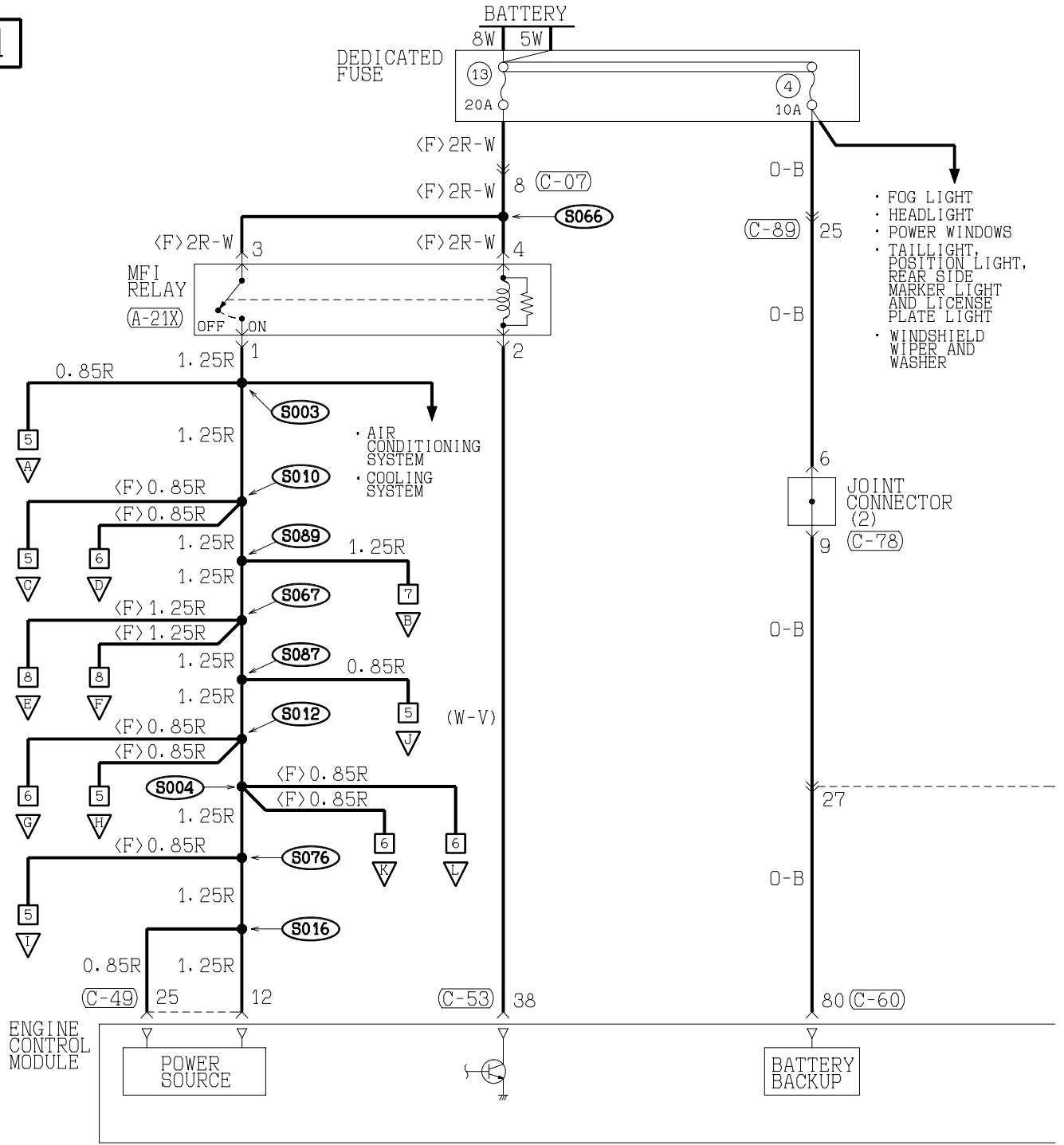

H1805M06AA

TSB Revision

2

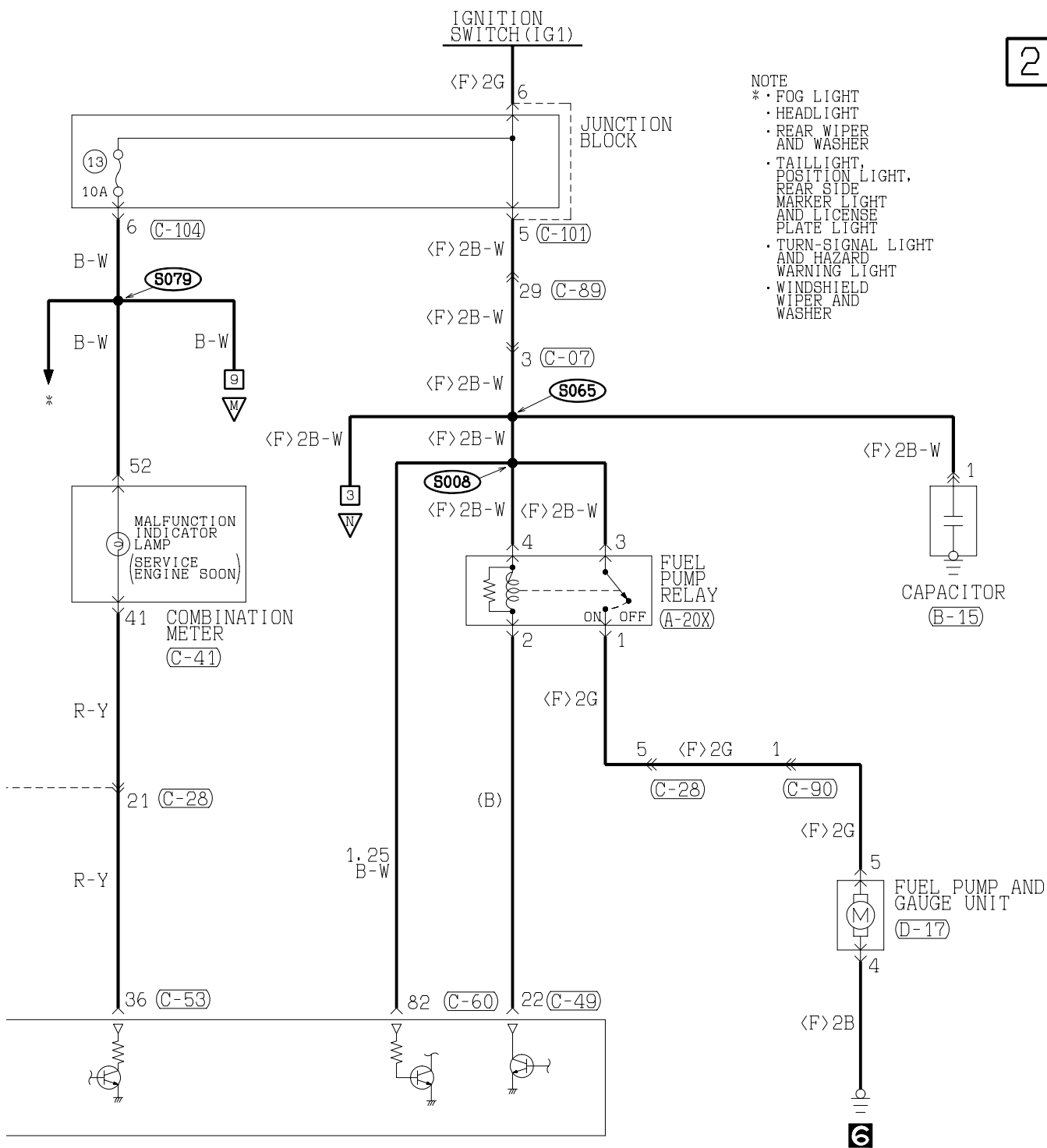

- NOTE
- \* FOG LIGHT
  - HEADLIGHT
  - REAR WIPER AND WASHER
  - TAILLIGHT, POSITION LIGHT, REAR SIDE MARKER LIGHT AND LICENSE PLATE LIGHT
  - TURN-SIGNAL LIGHT AND HAZARD WARNING LIGHT
  - WINDSHIELD WIPER AND WASHER

(C-49) (MU803773)

1	2	3	4	5	6	7	8	9	10	11	12	13
14	15	16	17	18	19	20	21	22	23	24	25	26

(C-53) (MU803771)

31	32	33	34	35	36	37	38
39	40	41	42	43	44	45	46

(C-60) (MU803772)

71	72	73	74	75	76	77	78	79	80	81
82	83	84	85	86	87	88	89	90	91	92

(C-78)

1	2	3	4	5	6	7	8	9	10	11
12	13	14	15	16	17	18	19	20	21	22
23	24	25	26	27	28	29	30	31	32	33

(C-89)

1	2	3	4	5	6	7	8	9	10	11	12	13
14	15	16	17	18	19	20	21	22	23	24	25	
26	27	28	29				30	31			38	
32	33	34			35		36	37				

WIRE COLOR CODE

B : BLACK      BR : BROWN      G : GREEN      GR : GRAY

L : BLUE      LG : LIGHT GREEN      O : ORANGE      P : PINK

R : RED      SB : SKY BLUE      V : VIOLET      W : WHITE

Y : YELLOW

H1S05M06AB

TSB Revision

MFI SYSTEM <2.4L ENGINE-M/T> (CONTINUED)

3

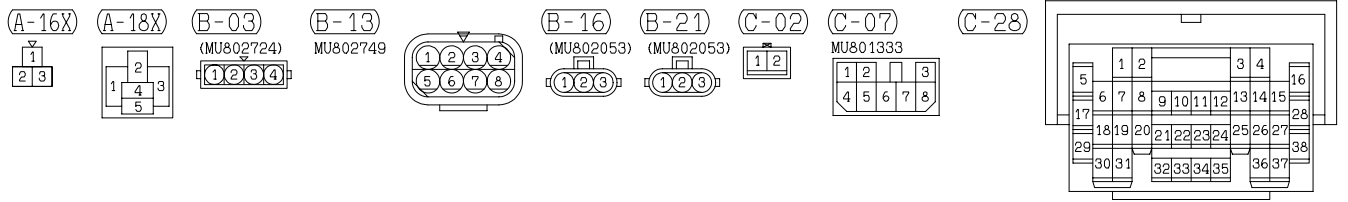
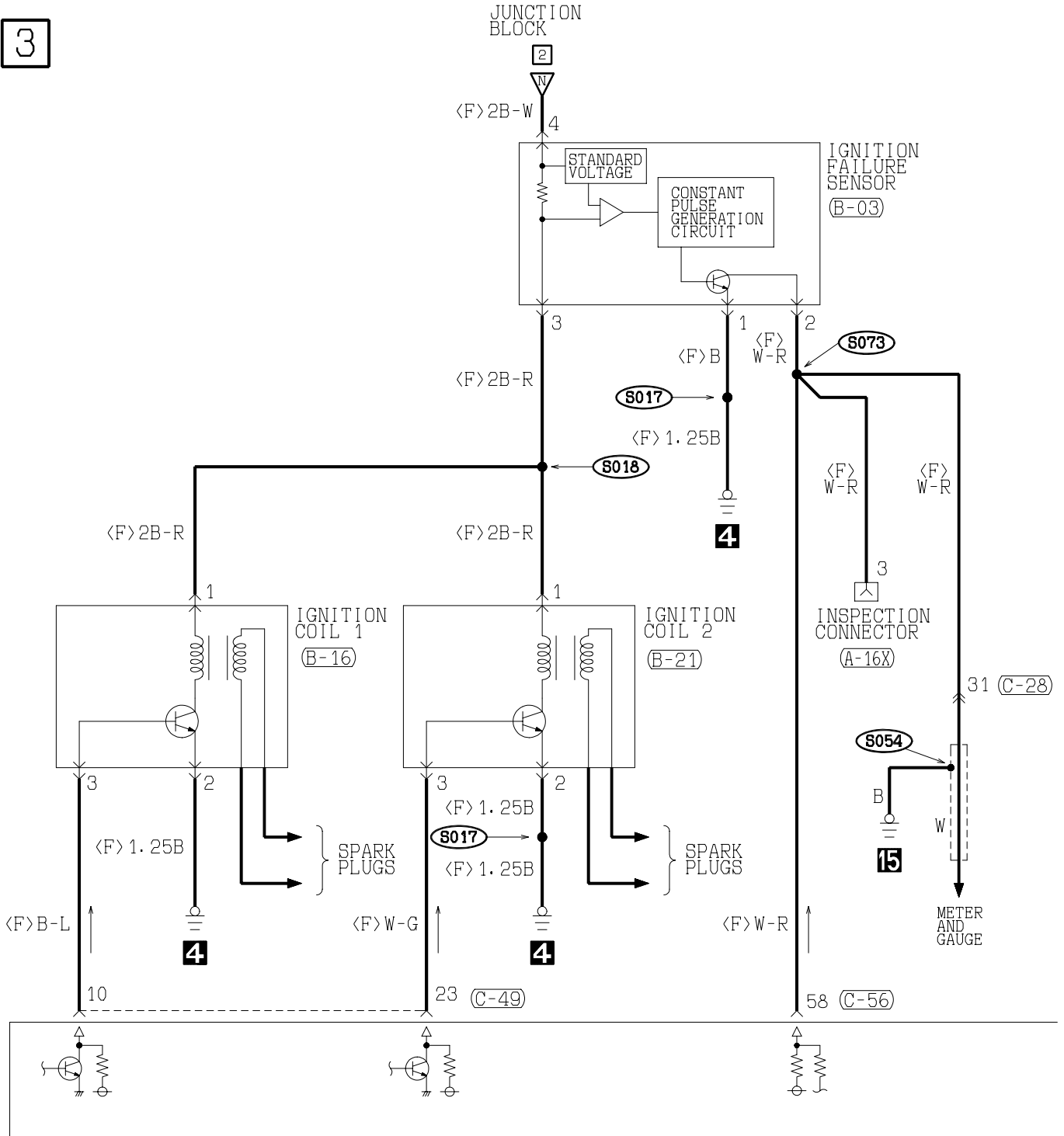

H1S05M06BA

TSB Revision



MFI SYSTEM <2.4L ENGINE-M/T> (CONTINUED)

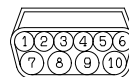
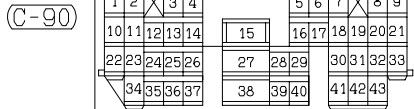
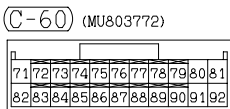
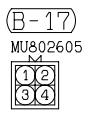
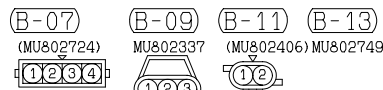
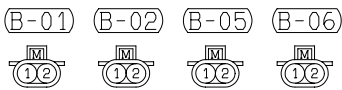
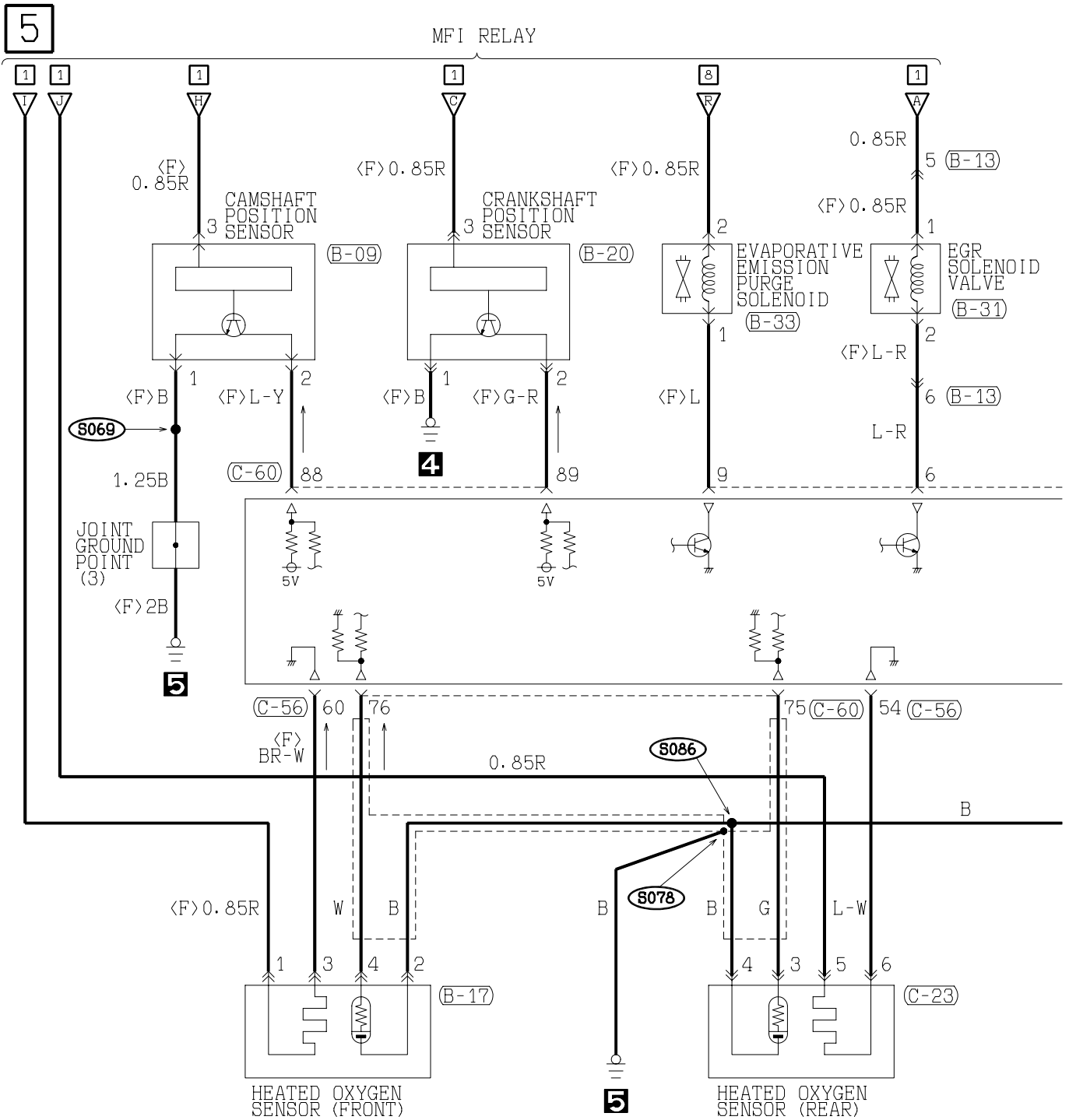

H1S05M06CA

TSB Revision



6

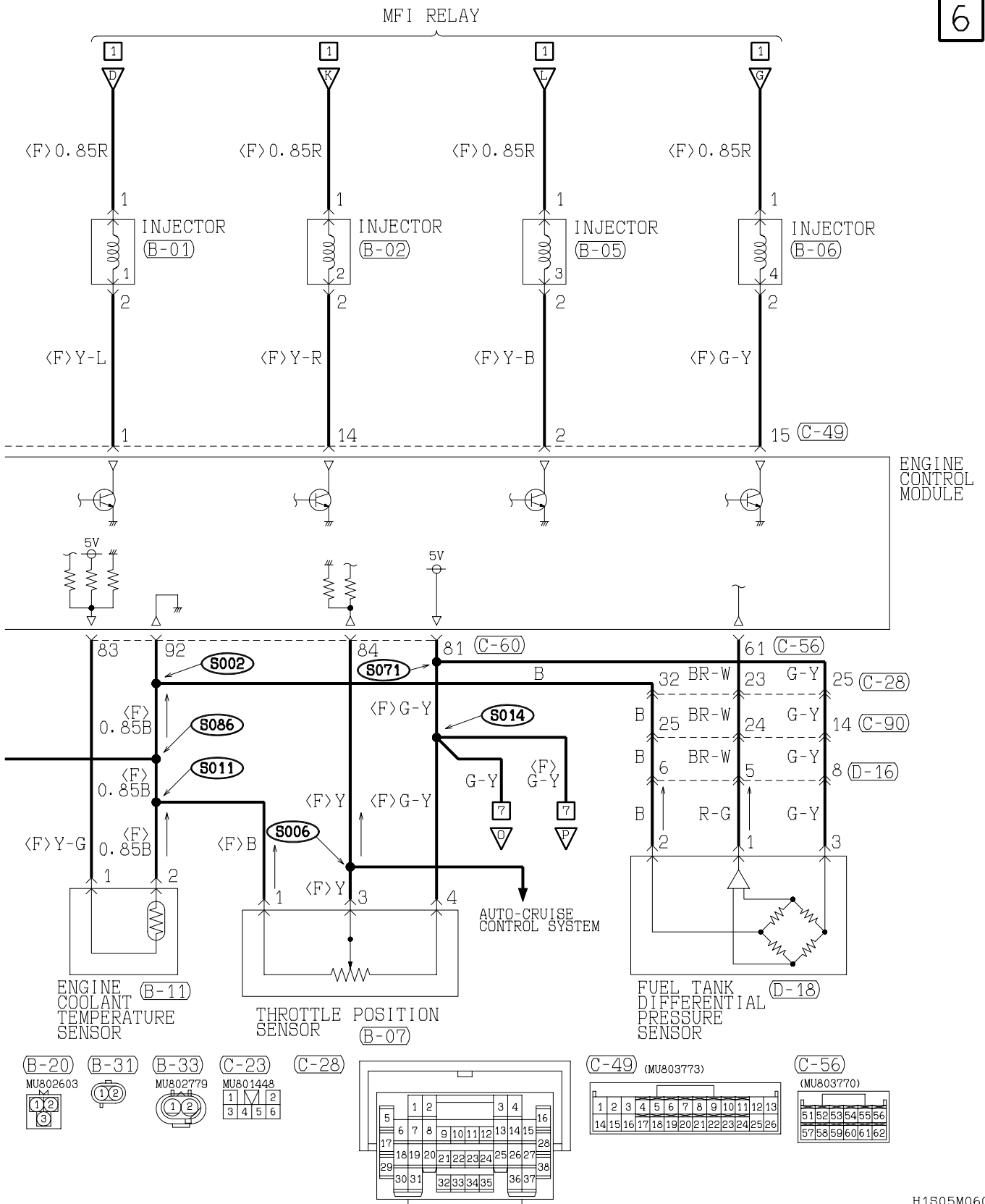

TSB Revision



8

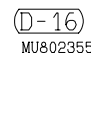
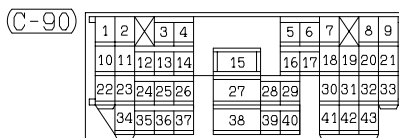
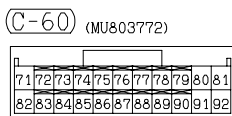
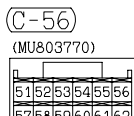
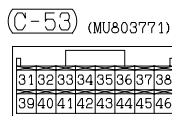
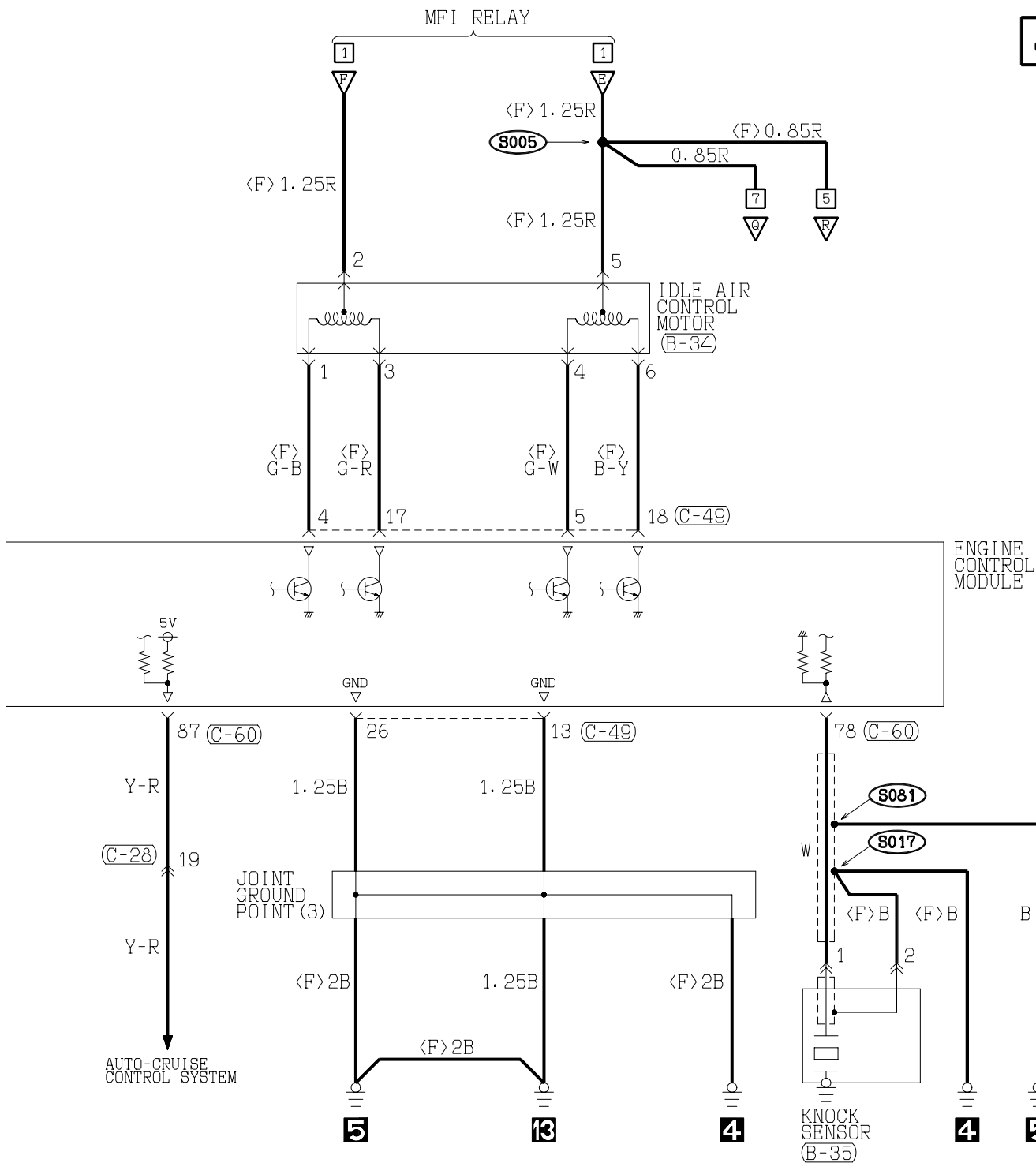

WIRE COLOR CODE  
B : BLACK  
BR : BROWN  
W : WHITE  
V : VIOLET

LG : LIGHT GREEN  
O : ORANGE  
SB : SKY BLUE

G : GREEN  
GR : GRAY  
P : PINK

L : BLUE  
R : RED  
Y : YELLOW

H1S05M06DB

TSB Revision



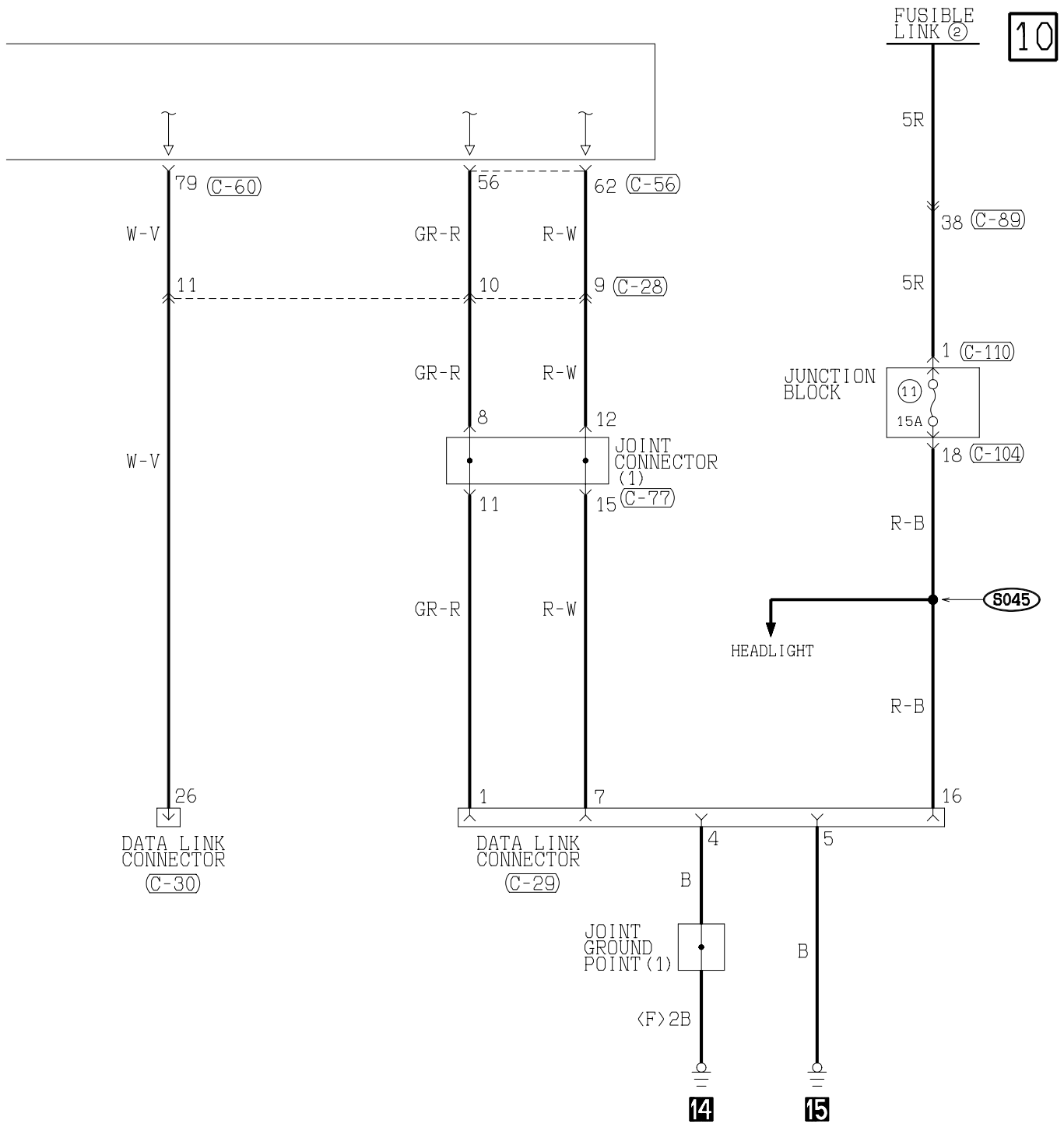

(C-77)

1	2	3	4	5	6	7	8	9	10	11
12	13	14	15	16	17	18	19	20	21	22
23	24	25	26	27	28	29	30	31	32	33

(C-78)

1	2	3	4	5	6	7	8	9	10	11
12	13	14	15	16	17	18	19	20	21	22
23	24	25	26	27	28	29	30	31	32	33

(C-89)

1	2	3	4	5	6	7	8	9	10	11	12	13
14	15	16	17	18	19	20	21	22	23	24	25	
26	27	28	29			30	31			38		
32	33	34	35			36	37					

(C-104)

1	2	3	4	5	6	7	8	9		
10	11	12	13	14	15	16	17	18	19	20

(C-110)

1
---

# MFI SYSTEM <2.4L ENGINE-A/T>

M1901000800123

1

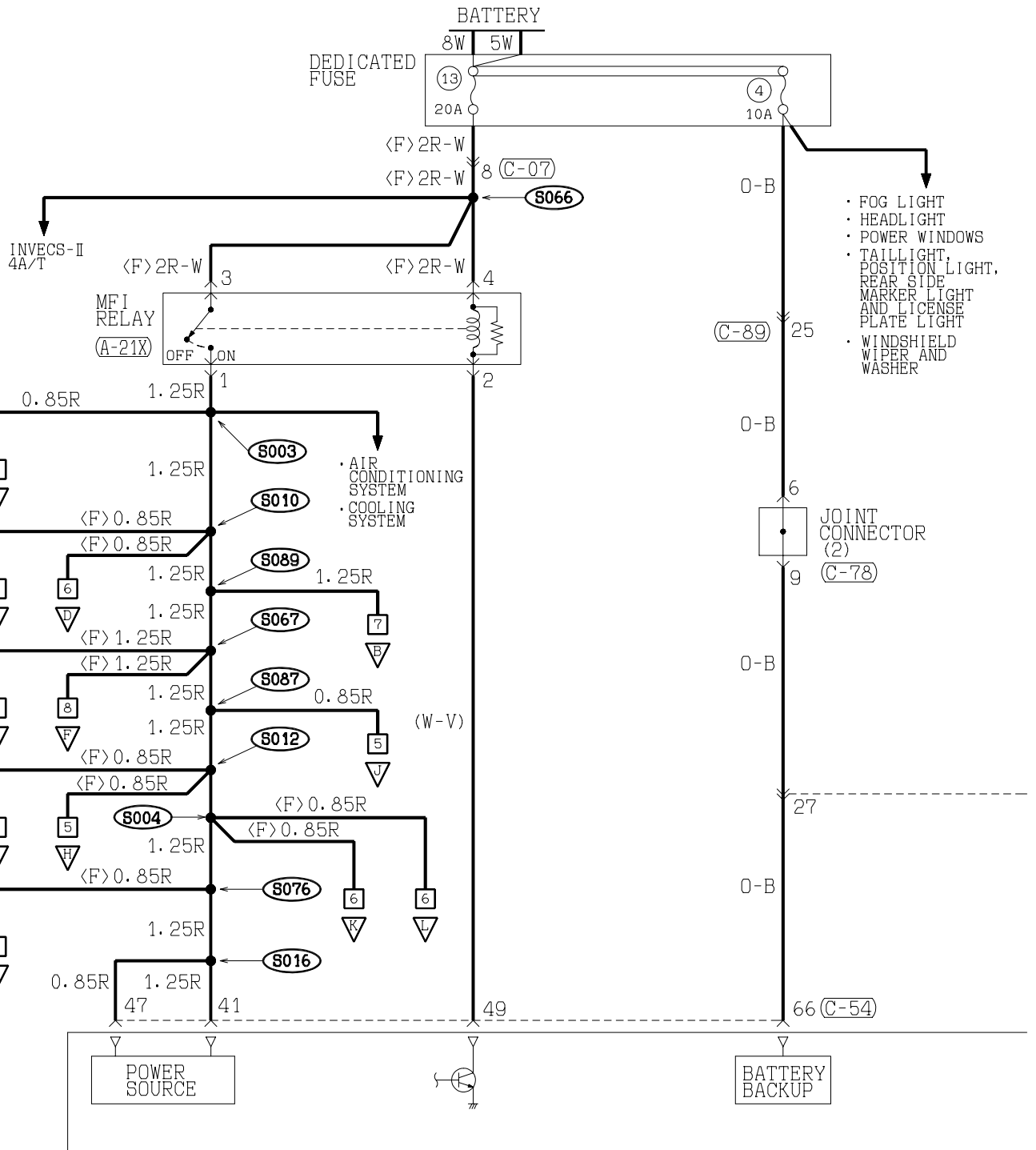

(A-20X)

(A-21X)

(B-15)

(C-07)

(MU801211) MU801333

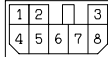

(C-28)

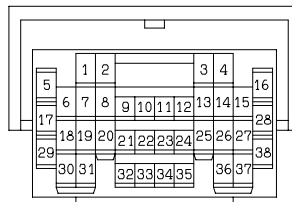

(C-41)

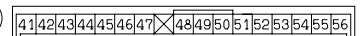

(C-89)

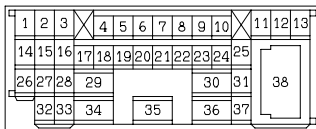

(C-90)

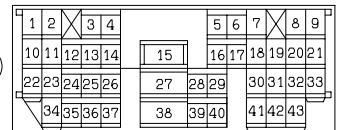

H1805M07AA

TSB Revision

2

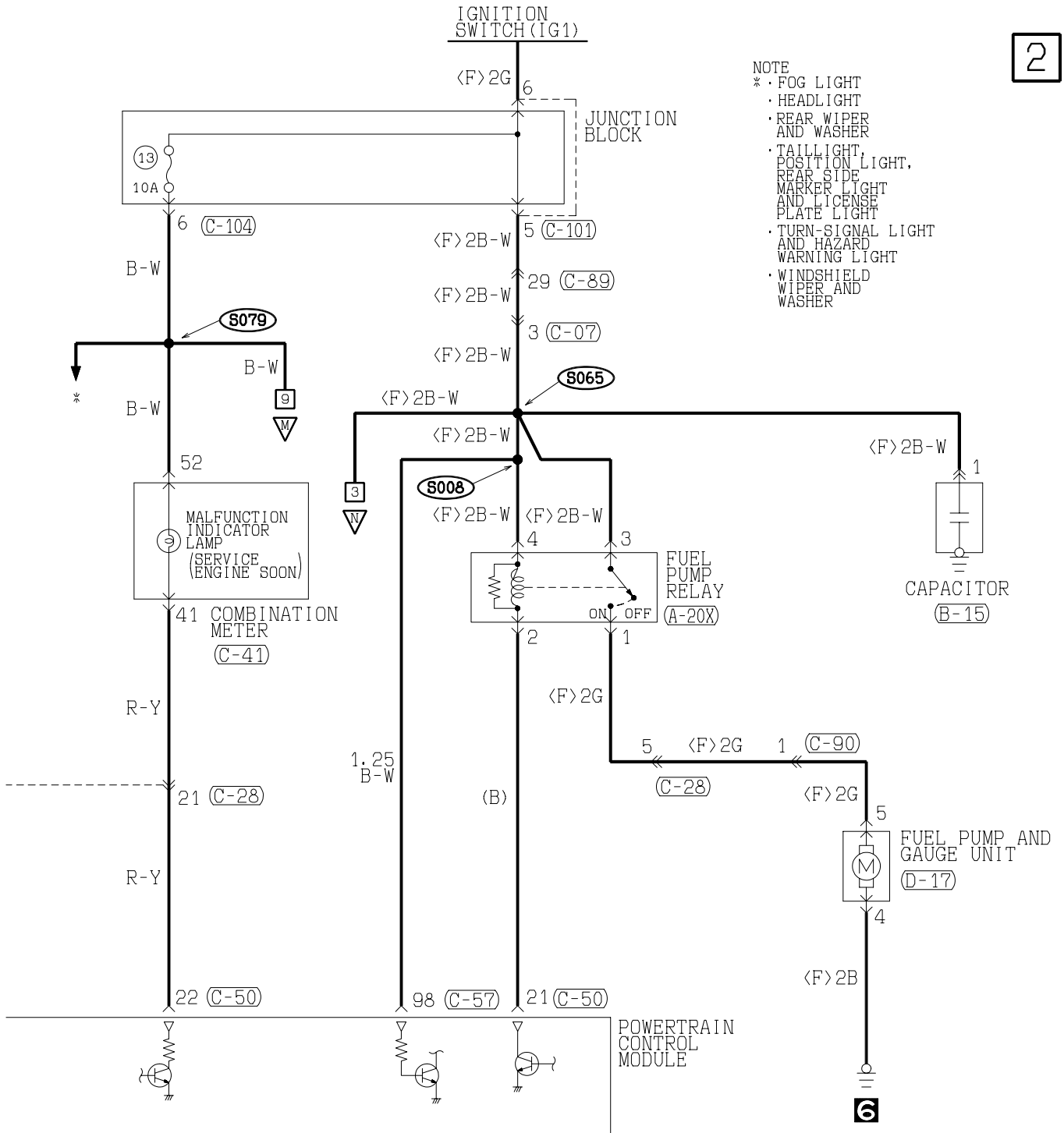

(C-50) (MU803784)

1	2	3	4	5	6	7	8
9	10	11	12	13	14	15	16
17	18	19	20	21	22	23	24
25	26	27	28	29	30	31	32
33	34	35					

(C-54) (MU803781)

41	42	43	44	45	46
47	48	49	50	51	52
53	54	55	56	57	58
59	60	61	62	63	64
65	66				

(C-57) (MU803782)

71	72	73	74	75	76	77
78	79	80	81	82	83	84
85	86	87	88	89	90	91
92	93	94	95	96	97	98

(C-78)

1	2	3	4	5	6	7	8	9	10	11
12	13	14	15	16	17	18	19	20	21	22
23	24	25	26	27	28	29	30	31	32	33

(C-101) MU801331

1	2
3	4
5	6

(C-104) MU801457

1	2	3	4	5	6	7	8	9
10	11	12	13	14	15	16	17	18
19	20							

(D-17) (MU802058)



WIRE COLOR CODE  
B : BLACK BR : BROWN G : GREEN GR : GRAY  
L : BLUE LG : LIGHT GREEN O : ORANGE P : PINK  
R : RED SB : SKY BLUE V : VIOLET W : WHITE  
Y : YELLOW

H1S05M07AB

MFI SYSTEM <2.4L ENGINE-A/T> (CONTINUED)

3

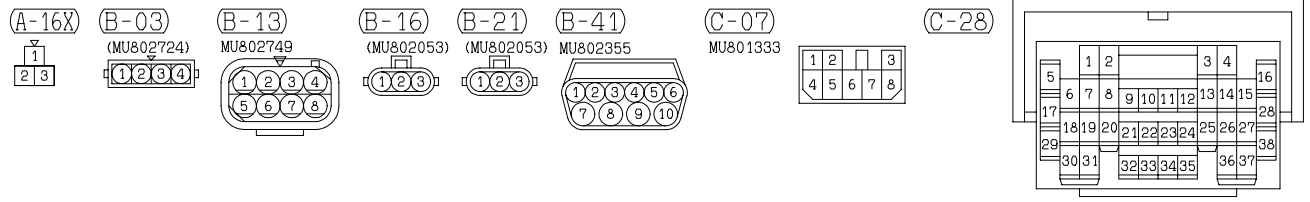
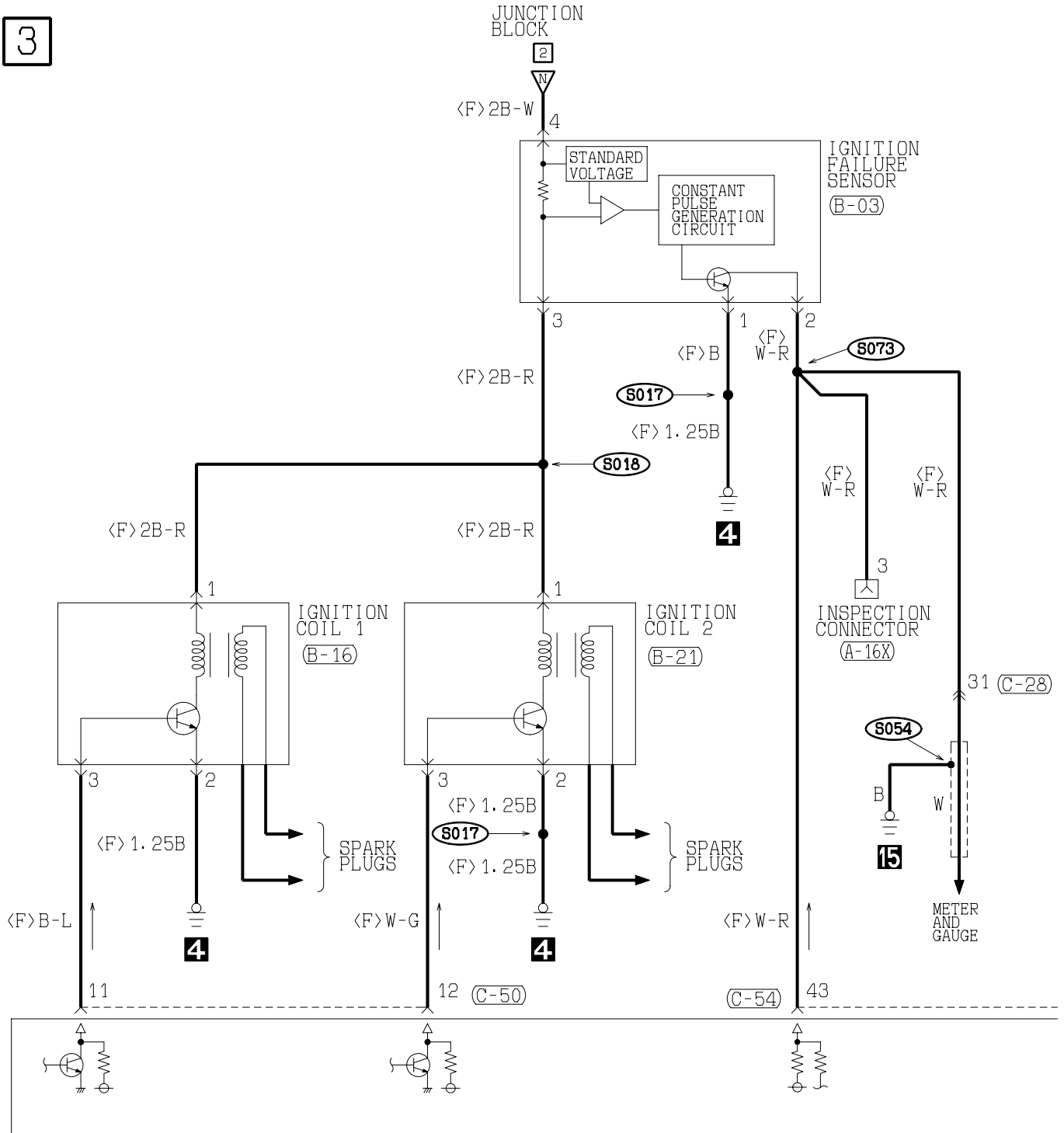

H1S05M07BA

TSB Revision



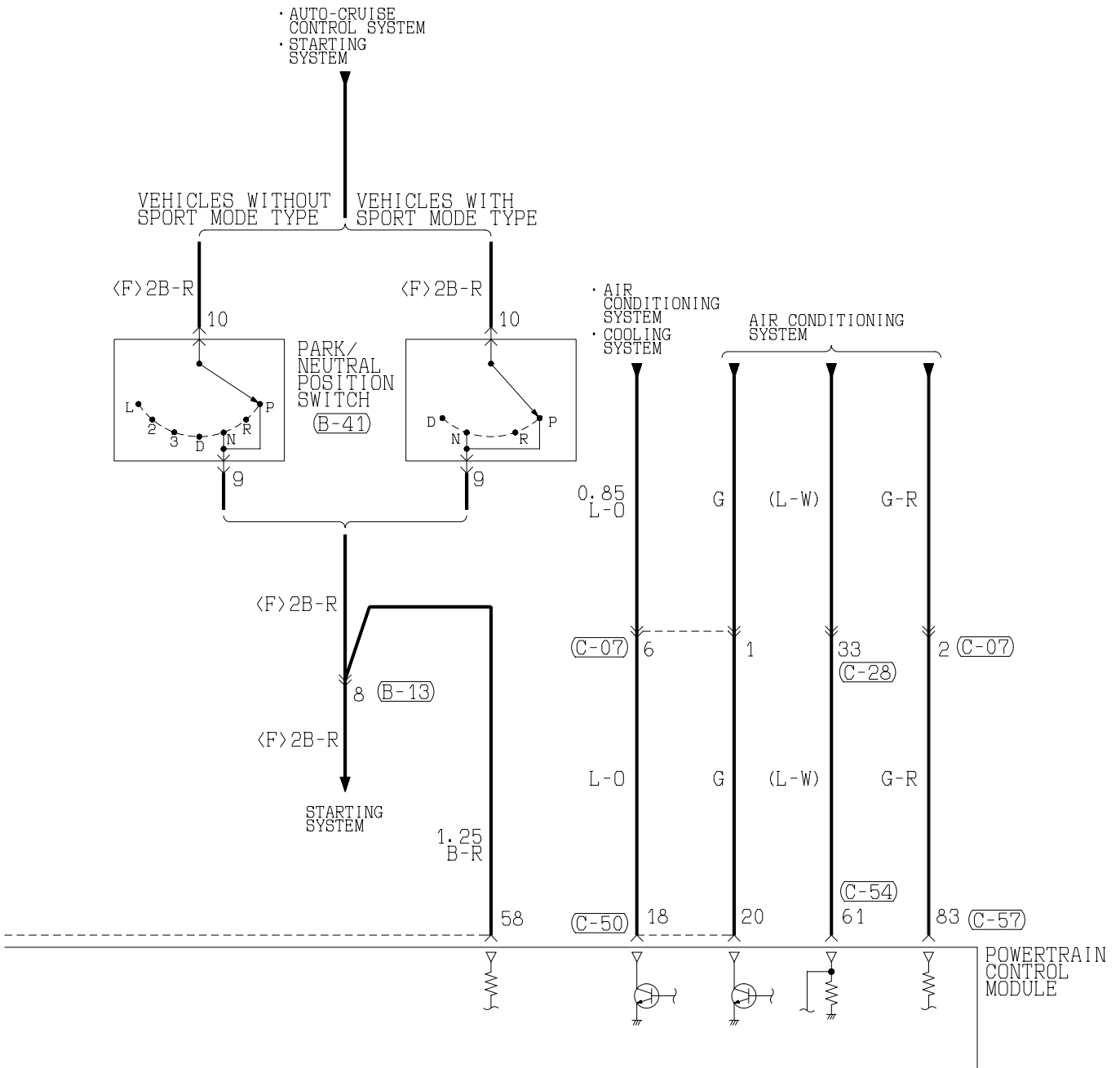

(C-50) (MU803784)

1	2	3	4	5	6	7	8
9	10	11	12	13	14	15	16
17	18	19	20	21	22	23	24
25	26	27	28	29	30	31	32
33	34	35					

(C-54) (MU803781)

41	42	43	44	45	46
47	48	49	50	51	52
53	54	55	56	57	58
59	60	61	62	63	64
65	66				

(C-57) (MU803782)

71	72	73	74	75	76	77
78	79	80	81	82	83	84
85	86	87	88	89	90	91
92	93	94	95	96	97	98

WIRE COLOR CODE

B : BLACK      BR : BROWN  
P : PINK      R : RED

G : GREEN      SB : SKY BLUE

GR : GRAY      V : VIOLET

L : BLUE      W : WHITE

LG : LIGHT GREEN      Y : YELLOW

O : ORANGE

MFI SYSTEM <2.4L ENGINE-A/T> (CONTINUED)

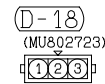
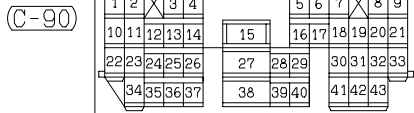
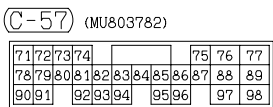
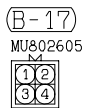
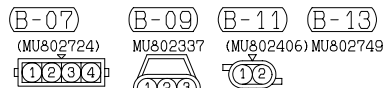
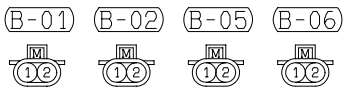
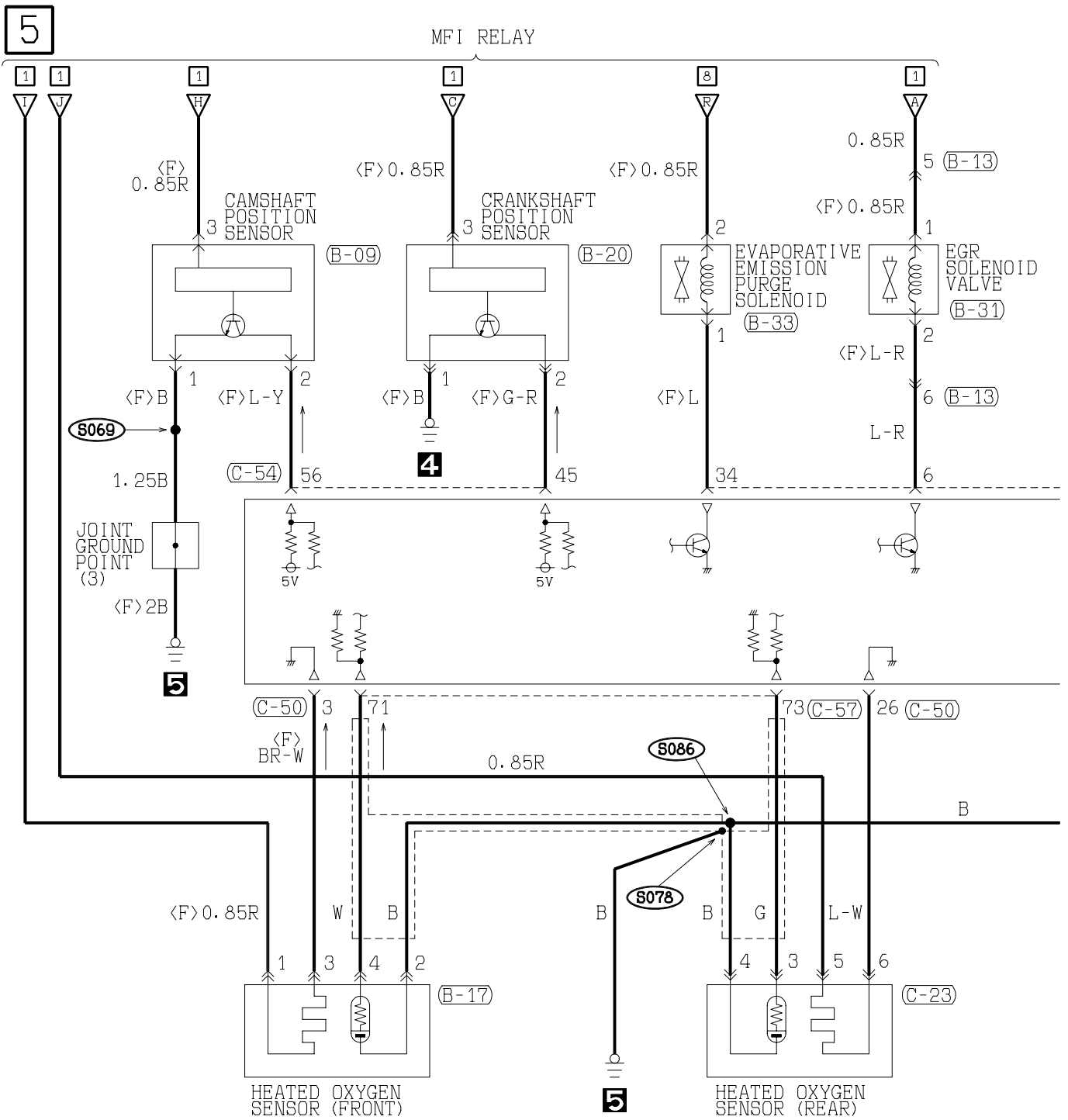

H1S05M07CA



MFI SYSTEM <2.4L ENGINE-A/T> (CONTINUED)

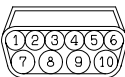
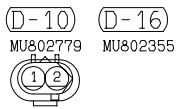
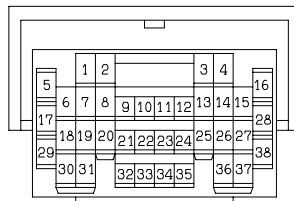
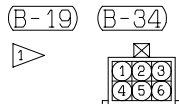
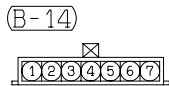
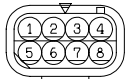
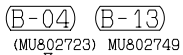
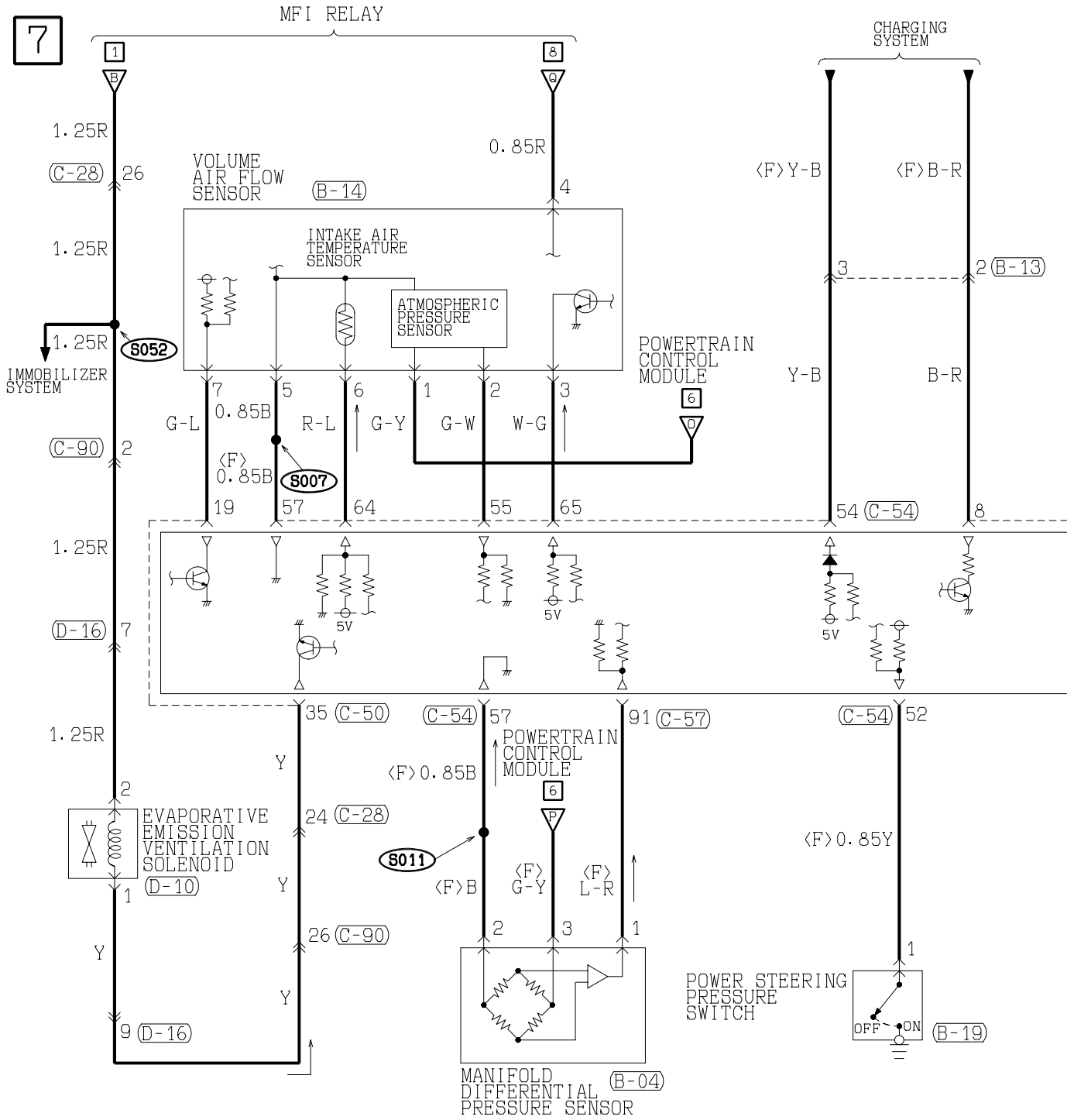

H1S05M07DA

TSB Revision

8

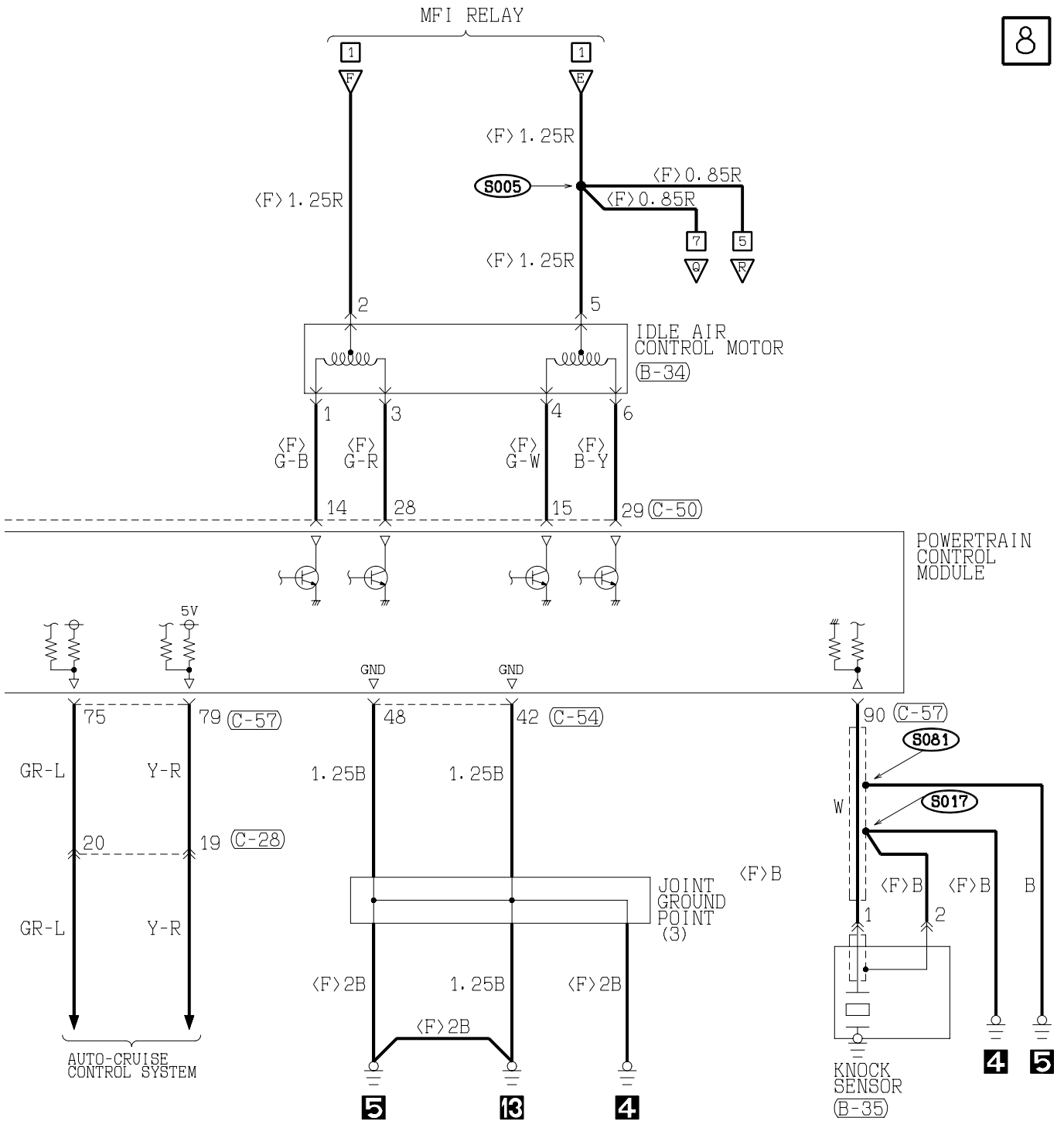

(C-50) (MU803784)

1	2	3	4	5	6	7	8							
9	10	11	12	13	14	15	16	17	18	19	20	21	22	23
24	25	26	27	28	29	30	31	32	33	34	35			

(C-54) (MU803781)

41	42	43	44	45	46					
47	48	49	50	51	52	53	54	55	56	57
58	59	60	61	62	63	64	65	66		

(C-57) (MU803782)

71	72	73	74	75	76	77					
78	79	80	81	82	83	84	85	86	87	88	89
90	91	92	93	94	95	96	97	98			

(C-90)

1	2	3	4	5	6	7	8	9			
10	11	12	13	14	15	16	17	18	19	20	21
22	23	24	25	26	27	28	29	30	31	32	33
34	35	36	37	38	39	40	41	42	43		

WIRE COLOR CODE  
B : BLACK LG : LIGHT GREEN  
BR : BROWN O : ORANGE  
W : WHITE SB : SKY BLUE  
V : VIOLET

G : GREEN L : BLUE  
GR : GRAY R : RED  
P : PINK Y : YELLOW

H1S05M07DB

TSB Revision

MFI SYSTEM <2.4L ENGINE-A/T> (CONTINUED)

9

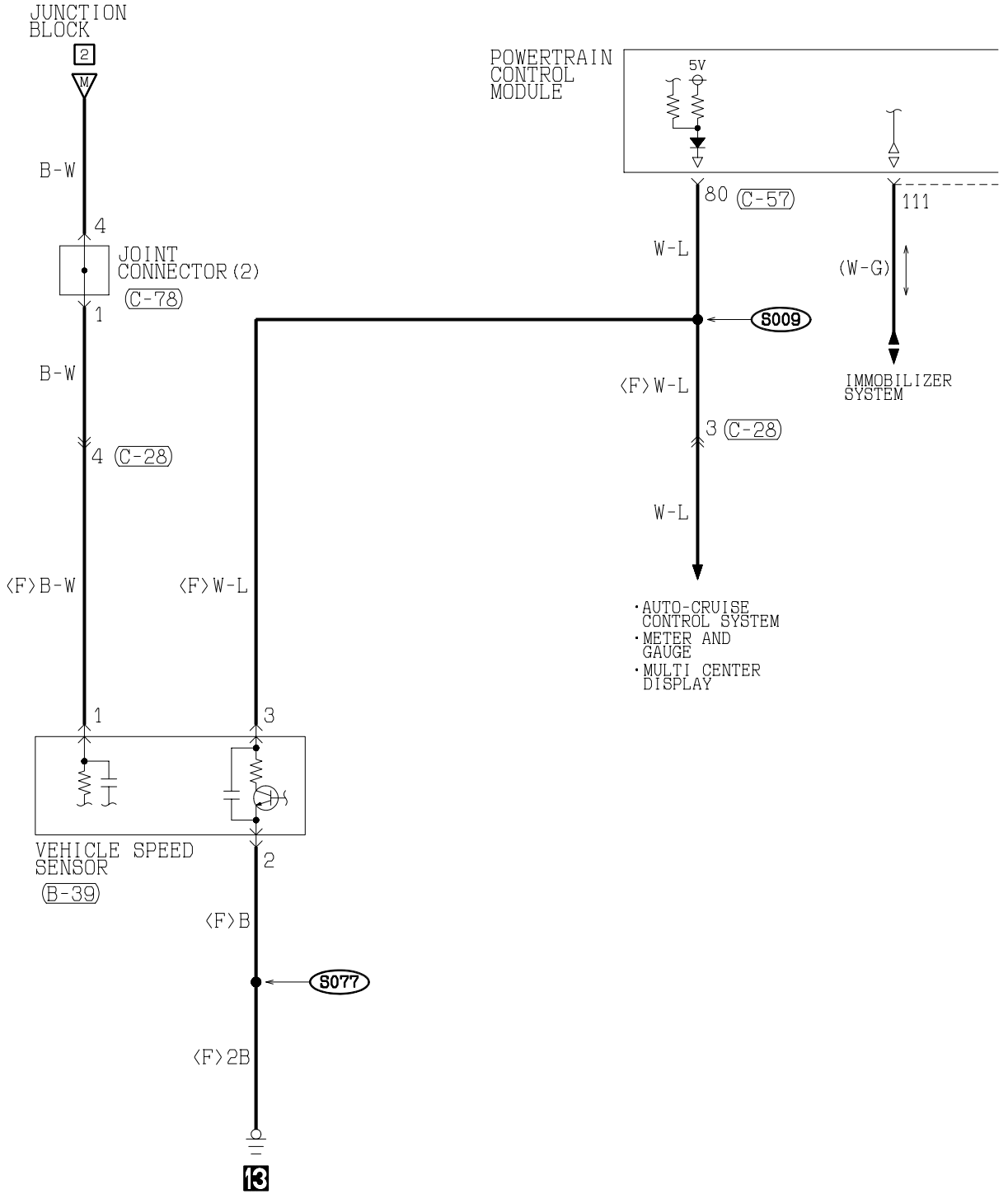

- AUTO-CRUISE CONTROL SYSTEM
- METER AND GAUGE
- MULTI CENTER DISPLAY

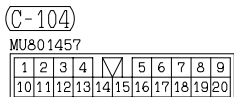
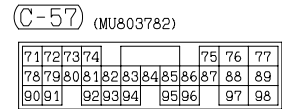
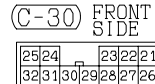
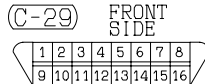
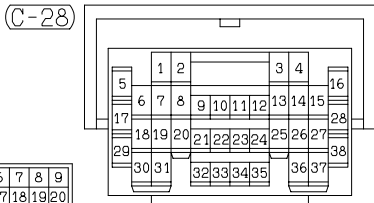

TSB Revision

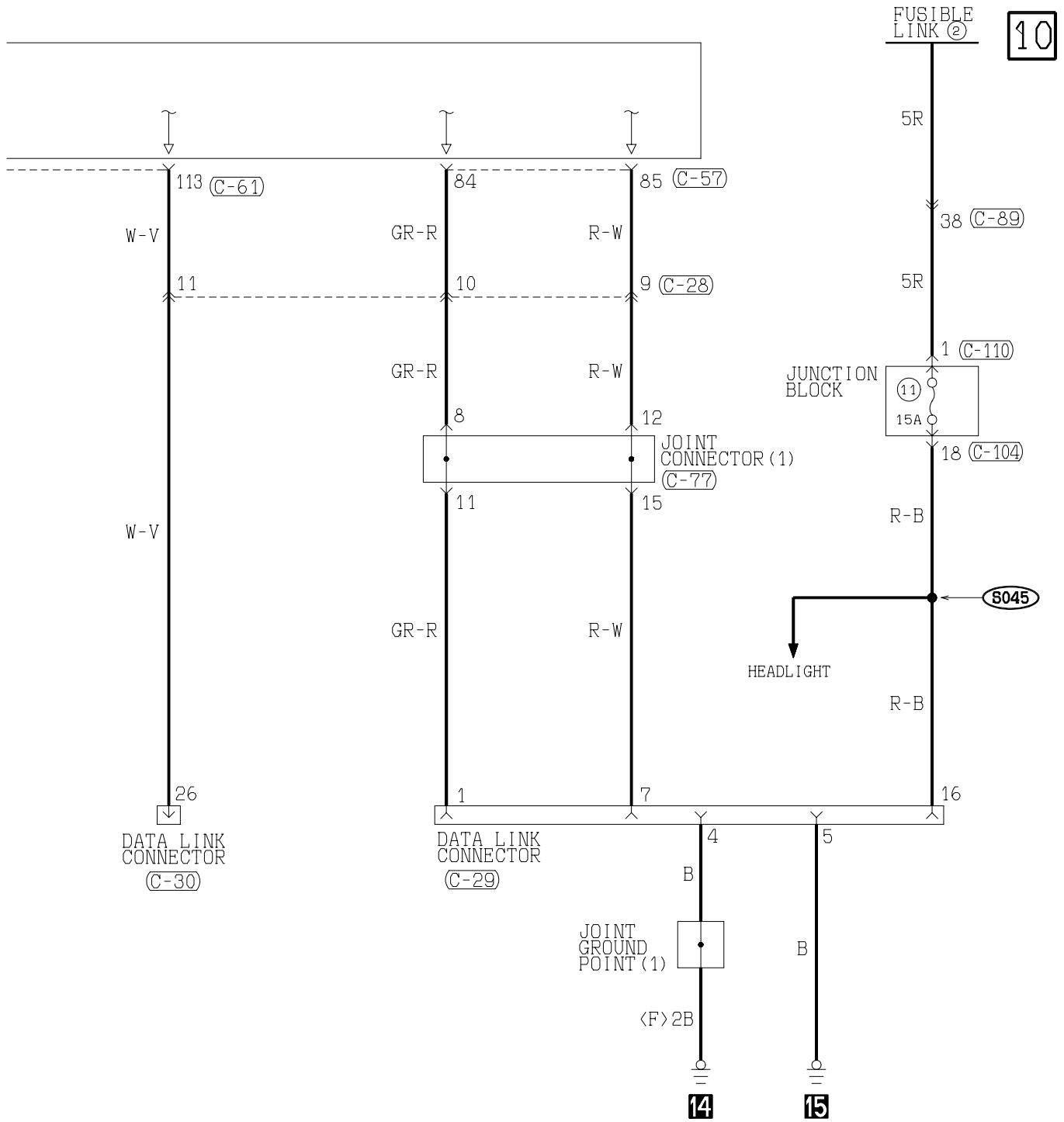

(C-61) (MU803783)

101	102	103	104	105	106	107						
108	109	110	111	112	113	114	115	116	117	118	119	120
121	122	123	124	125	126	127	128	129	130			

(C-77)

1	2	3	4	5	6	7	8	9	10	11
12	13	14	15	16	17	18	19	20	21	22
23	24	25	26	27	28	29	30	31	32	33

(C-78)

1	2	3	4	5	6	7	8	9	10	11
12	13	14	15	16	17	18	19	20	21	22
23	24	25	26	27	28	29	30	31	32	33

(C-89)

1	2	3	4	5	6	7	8	9	10	11	12	13
14	15	16	17	18	19	20	21	22	23	24	25	38
26	27	28	29	30	31							
32	33	34	35	36	37							

WIRE COLOR CODE  
B : BLACK BR : BROWN  
P : PINK R : RED

G : GREEN GR : GRAY L : BLUE  
SB : SKY BLUE V : VIOLET W : WHITE

LG : LIGHT GREEN O : ORANGE  
Y : YELLOW

H1S05M07EB

TSB Revision

MFI SYSTEM <3.0L ENGINE-M/T>

1

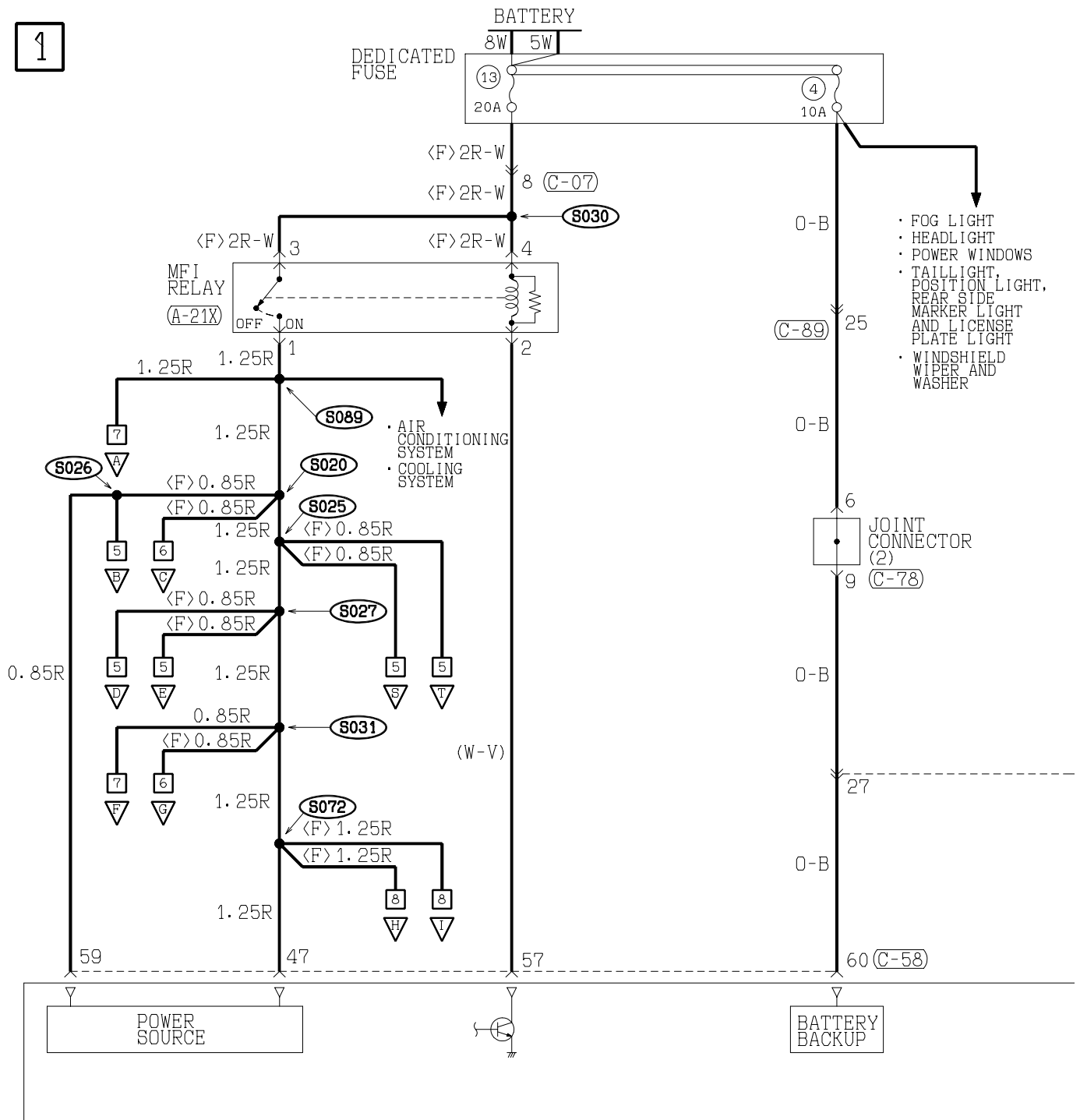

- FOG LIGHT
- HEADLIGHT
- POWER WINDOWS
- TAILLIGHT, POSITION LIGHT, REAR SIDE MARKER LIGHT AND LICENSE PLATE LIGHT
- WINDSHIELD WIPER AND WASHER

(A-20X)



(A-21X)



(C-07)

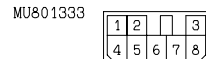

MU801333

(C-28)

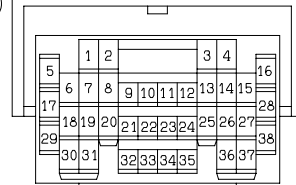

(C-41)

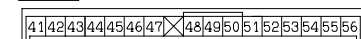

(C-89)

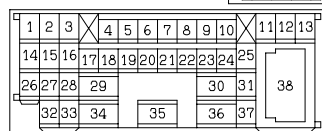

(C-90)

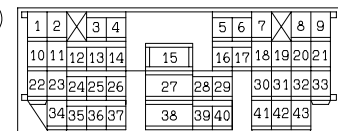

TSB Revision



2

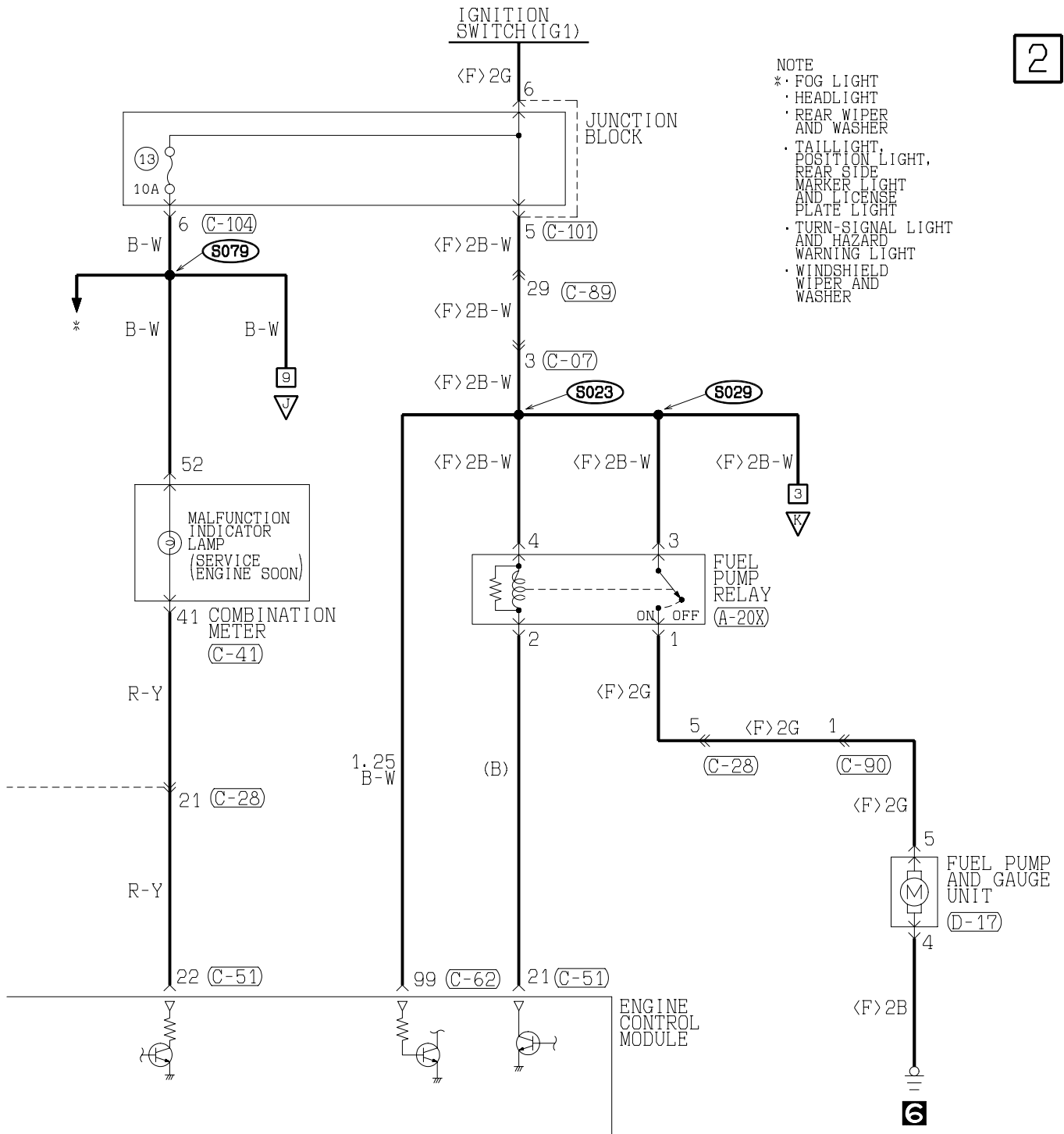

(C-51) (MU803784)

1	2	3	4	5	6	7	8							
9	10	11	12	13	14	15	16	17	18	19	20	21	22	23
24	25	26	27	28	29	30	31	32	33	34	35			

(C-58) (MU803782)

41	42	43	44	45	46	47					
48	49	50	51	52	53	54	55	56	57	58	59
60	61	62	63	64	65	66	67	68			

(C-62) (MU803783)

71	72	73	74	75	76	77						
78	79	80	81	82	83	84	85	86	87	88	89	90
91	92	93	94	95	96	97	98	99	100			

(C-78)

1	2	3	4	5	6	7	8	9	10	11
12	13	14	15	16	17	18	19	20	21	22
23	24	25	26	27	28	29	30	31	32	33

(C-101) MU801331

1	2		
3	4	5	6

(C-104) MU801457

1	2	3	4	5	6	7	8	9		
10	11	12	13	14	15	16	17	18	19	20

(D-17) (MU802058)



WIRE COLOR CODE

B : BLACK BR : BROWN G : GREEN GR : GRAY  
 BL : BLUE LG : LIGHT GREEN O : ORANGE P : PINK  
 RD : RED SB : SKY BLUE V : VIOLET W : WHITE  
 Y : YELLOW

H1S05M08AB

TSB Revision



4

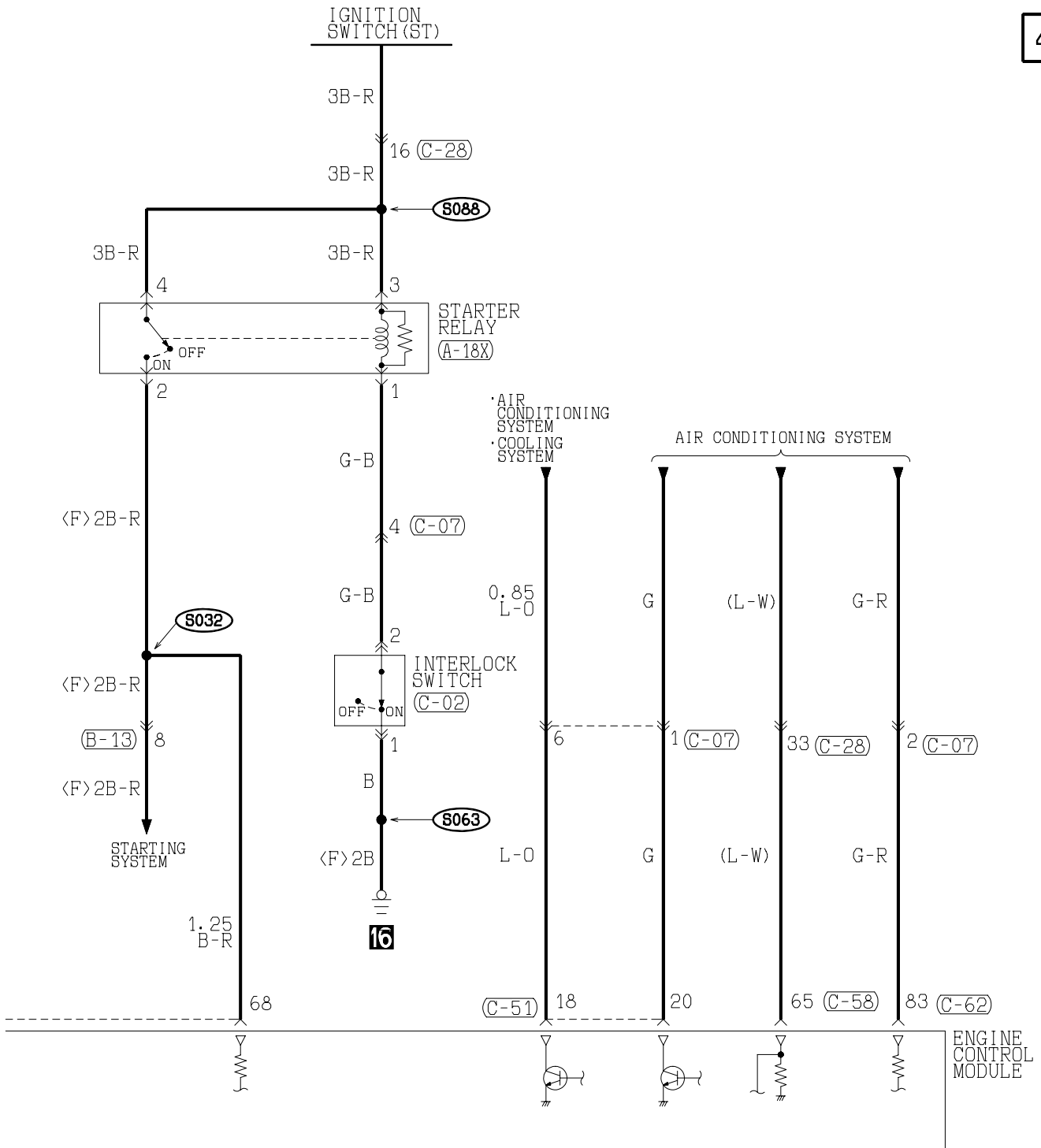

(C-51) (MU803784)

1	2	3	4	5	6	7	8							
9	10	11	12	13	14	15	16	17	18	19	20	21	22	23
24	25	26	27	28	29	30	31	32	33	34	35			

(C-58) (MU803782)

41	42	43	44	45	46	47					
48	49	50	51	52	53	54	55	56	57	58	59
60	61	62	63	64	65	66	67	68			

(C-62) (MU803783)

71	72	73	74	75	76	77						
78	79	80	81	82	83	84	85	86	87	88	89	90
91	92	93	94	95	96	97	98	99	100			

WIRE COLOR CODE  
 B : BLACK BR : BROWN G : GREEN GR : GRAY L : BLUE LG : LIGHT GREEN O : ORANGE  
 P : PINK R : RED SB : SKY BLUE V : VIOLET W : WHITE Y : YELLOW

H1S05M08BB

TSB Revision

MFI SYSTEM <3.0L ENGINE-M/T> (CONTINUED)

5

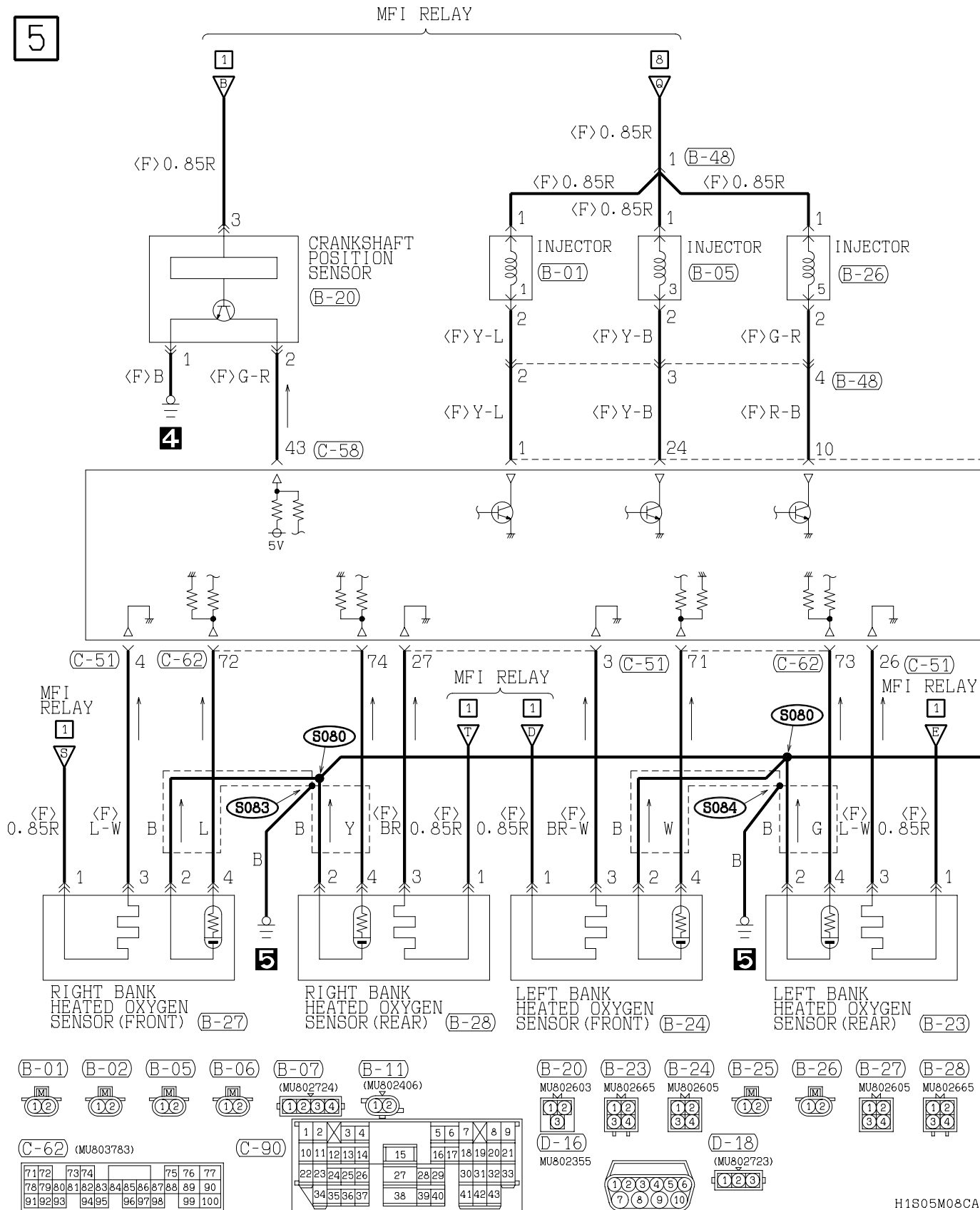

H1S05M08CA

TSB Revision

6

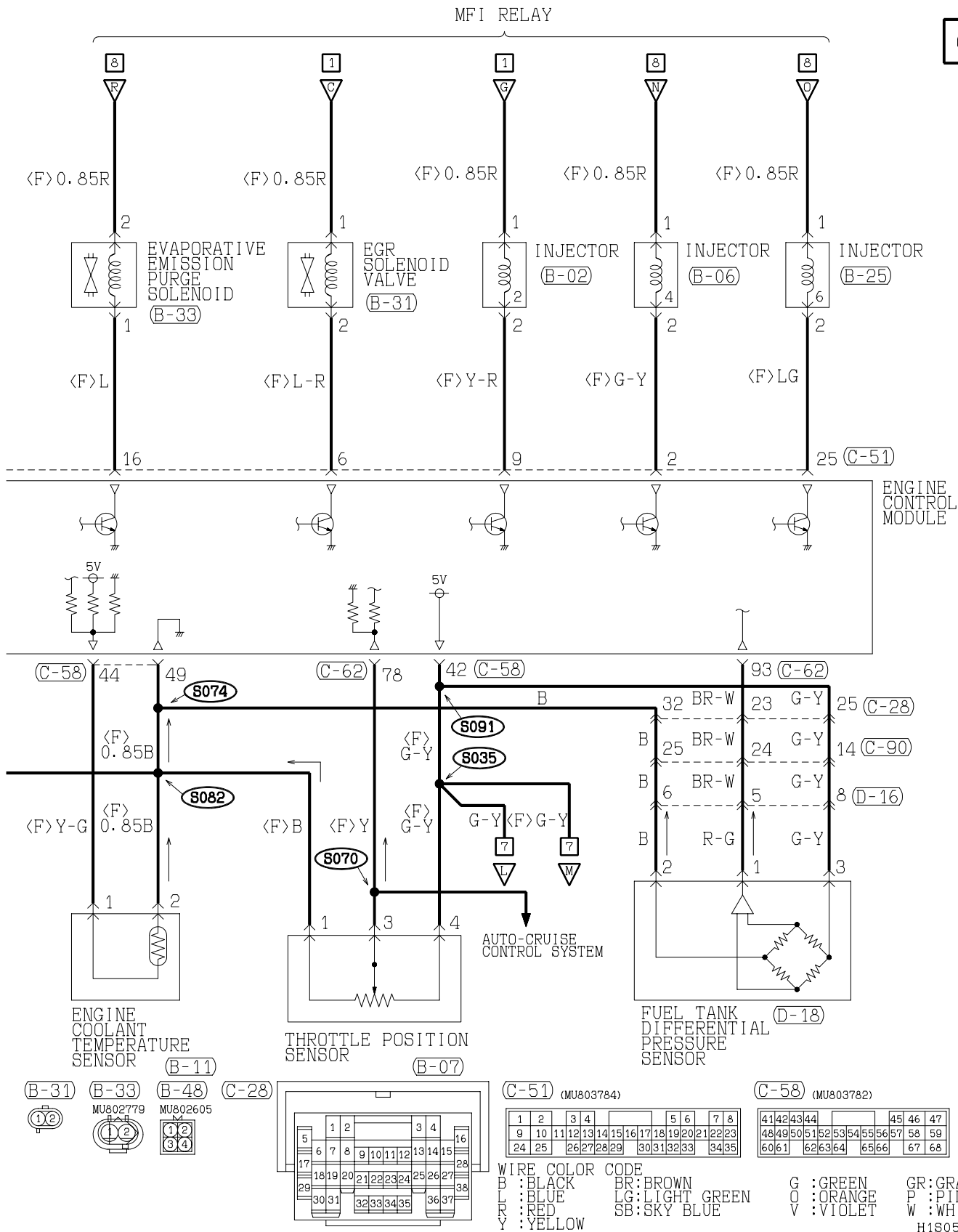

TSB Revision

MFI SYSTEM <3.0L ENGINE-M/T> (CONTINUED)

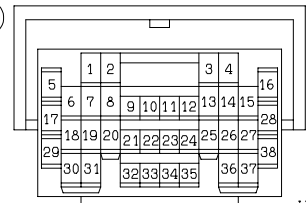
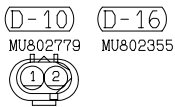
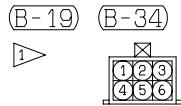
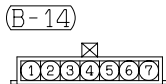
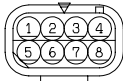
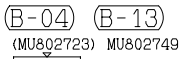
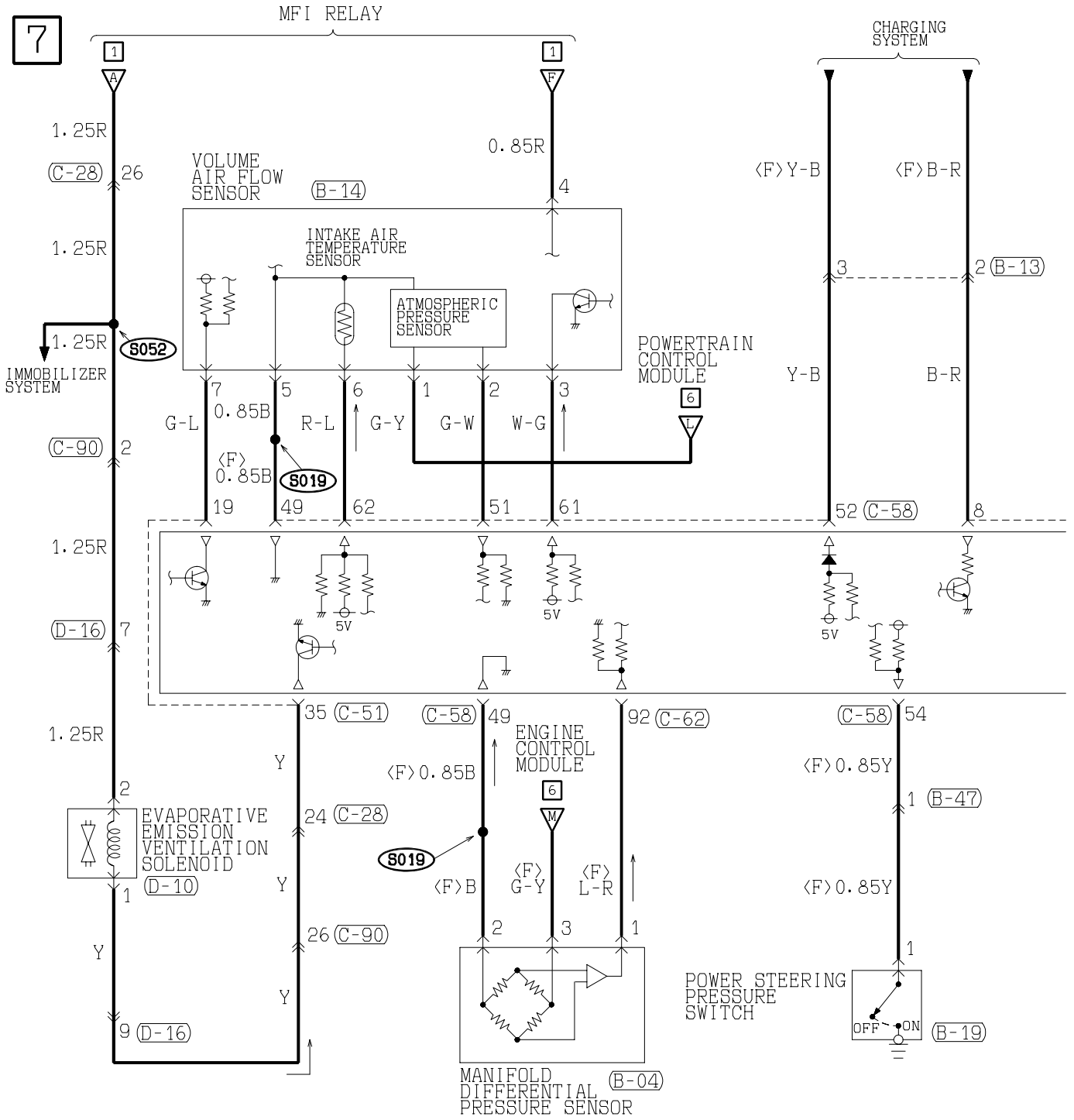

H1S05M08DA

8

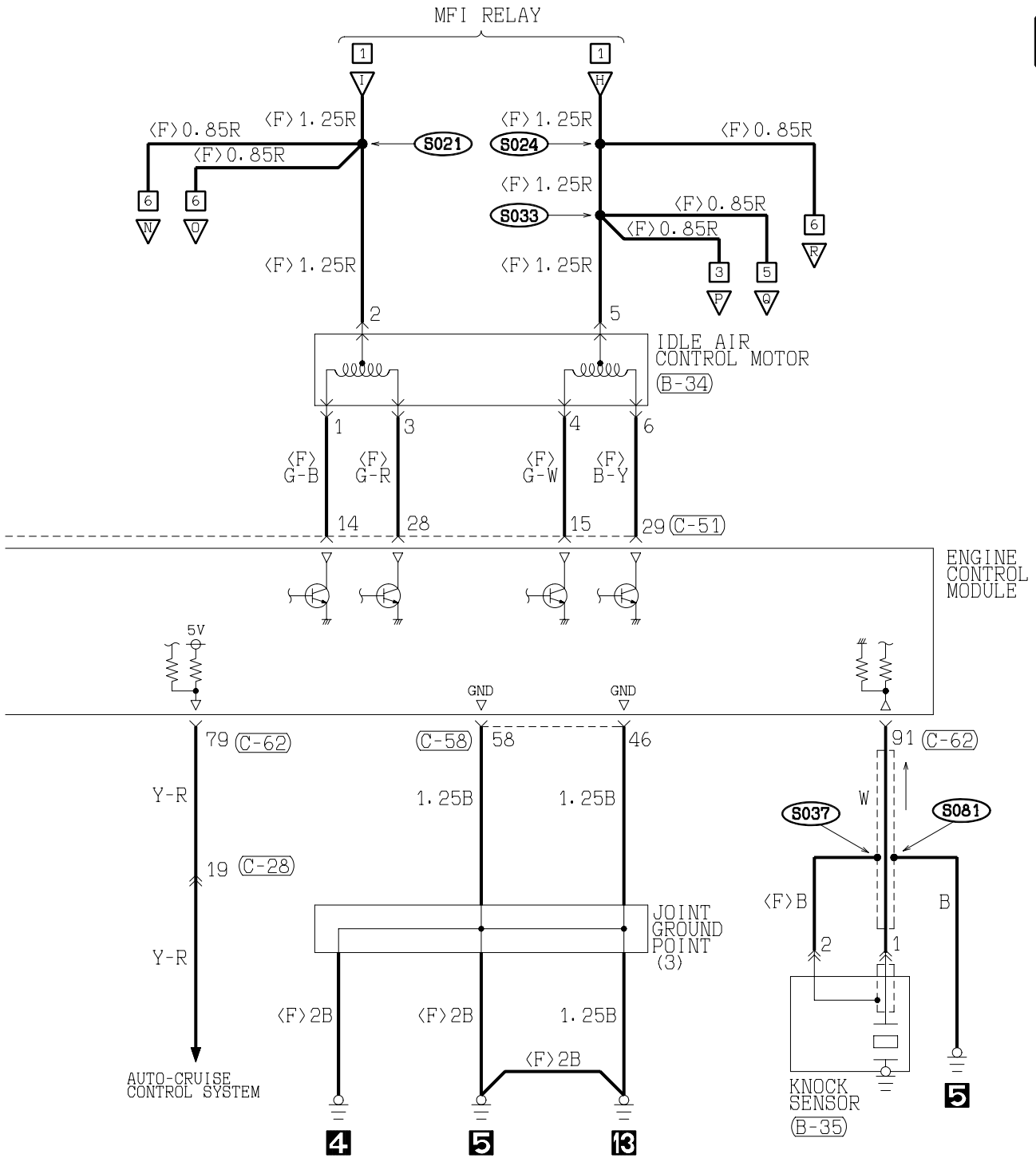

(C-51) (MU803784)

1	2	3	4	5	6	7	8							
9	10	11	12	13	14	15	16	17	18	19	20	21	22	23
24	25	26	27	28	29	30	31	32	33	34	35			

(C-58) (MU803782)

41	42	43	44	45	46	47					
48	49	50	51	52	53	54	55	56	57	58	59
60	61	62	63	64	65	66	67	68			

(C-62) (MU803783)

71	72	73	74	75	76	77						
78	79	80	81	82	83	84	85	86	87	88	89	90
91	92	93	94	95	96	97	98	99	100			

(C-90)

1	2	3	4	5	6	7	8	9			
10	11	12	13	14	15	16	17	18	19	20	21
22	23	24	25	26	27	28	29	30	31	32	33
34	35	36	37	38	39	40	41	42	43		

WIRE COLOR CODE  
 B : BLACK      LG : LIGHT GREEN      G : GREEN      L : BLUE  
 BR : BROWN      O : ORANGE      GR : GRAY      R : RED  
 W : WHITE      SB : SKY BLUE      P : PINK      Y : YELLOW  
 V : VIOLET

H1805M08DB

TSB Revision

MFI SYSTEM <3.0L ENGINE-M/T> (CONTINUED)

9

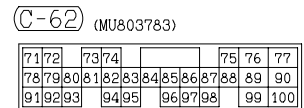
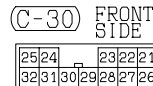
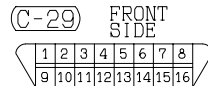
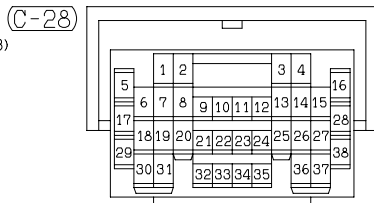
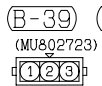
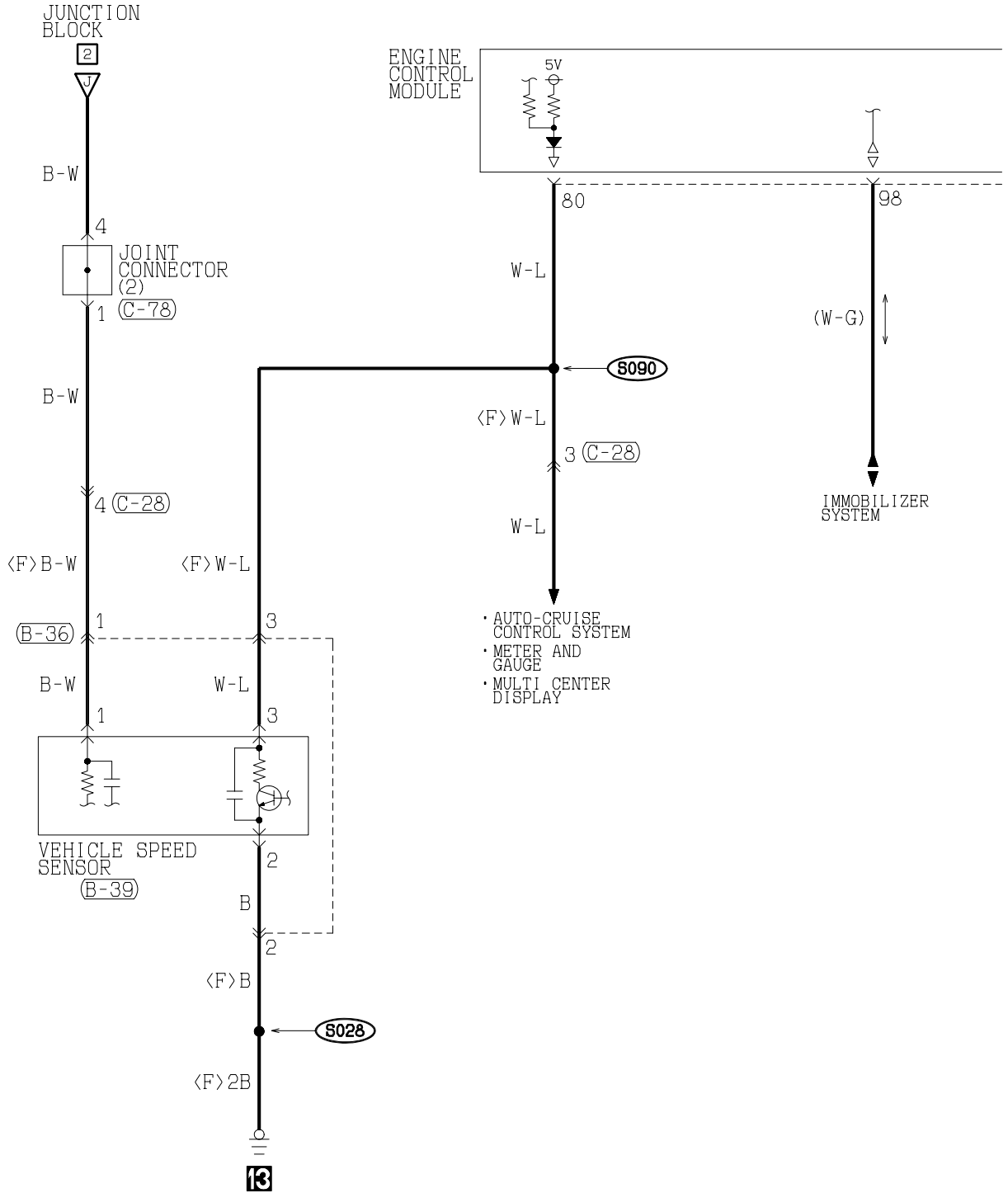

TSB Revision



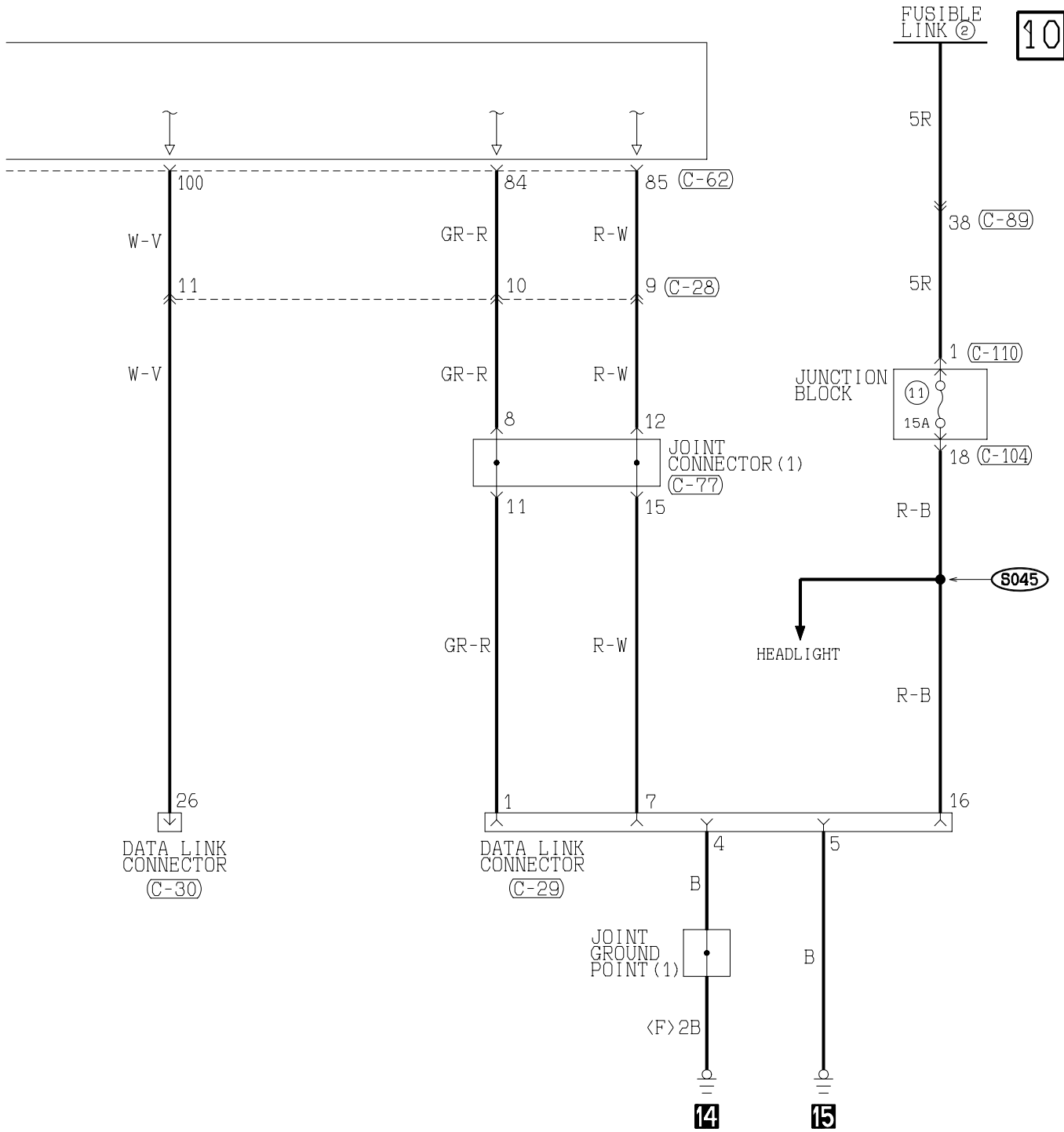

(C-77)

1	2	3	4	5	6	7	8	9	10	11
12	13	14	15	16	17	18	19	20	21	22
23	24	25	26	27	28	29	30	31	32	33

(C-78)

1	2	3	4	5	6	7	8	9	10	11
12	13	14	15	16	17	18	19	20	21	22
23	24	25	26	27	28	29	30	31	32	33

(C-89)

1	2	3	4	5	6	7	8	9	10	11	12	13
14	15	16	17	18	19	20	21	22	23	24	25	
26	27	28	29			30	31			32	33	
		34		35		36	37			38		

(C-104)

1	2	3	4	5	6	7	8	9		
10	11	12	13	14	15	16	17	18	19	20

(C-110)

1
---

WIRE COLOR CODE

B : BLACK BR : BROWN G : GREEN GR : GRAY L : BLUE LG : LIGHT GREEN O : ORANGE  
P : PINK R : RED SB : SKY BLUE V : VIOLET W : WHITE Y : YELLOW

H1S05M08EB

TSB Revision

# MFI SYSTEM <3.0L ENGINE-A/T>

1

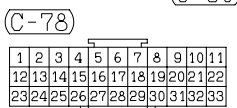
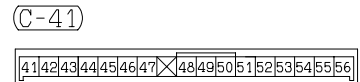
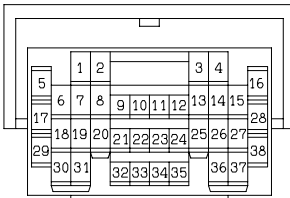
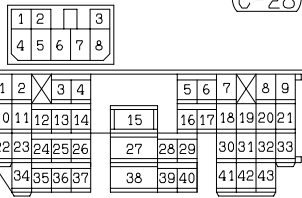
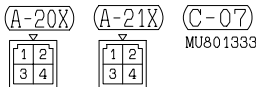
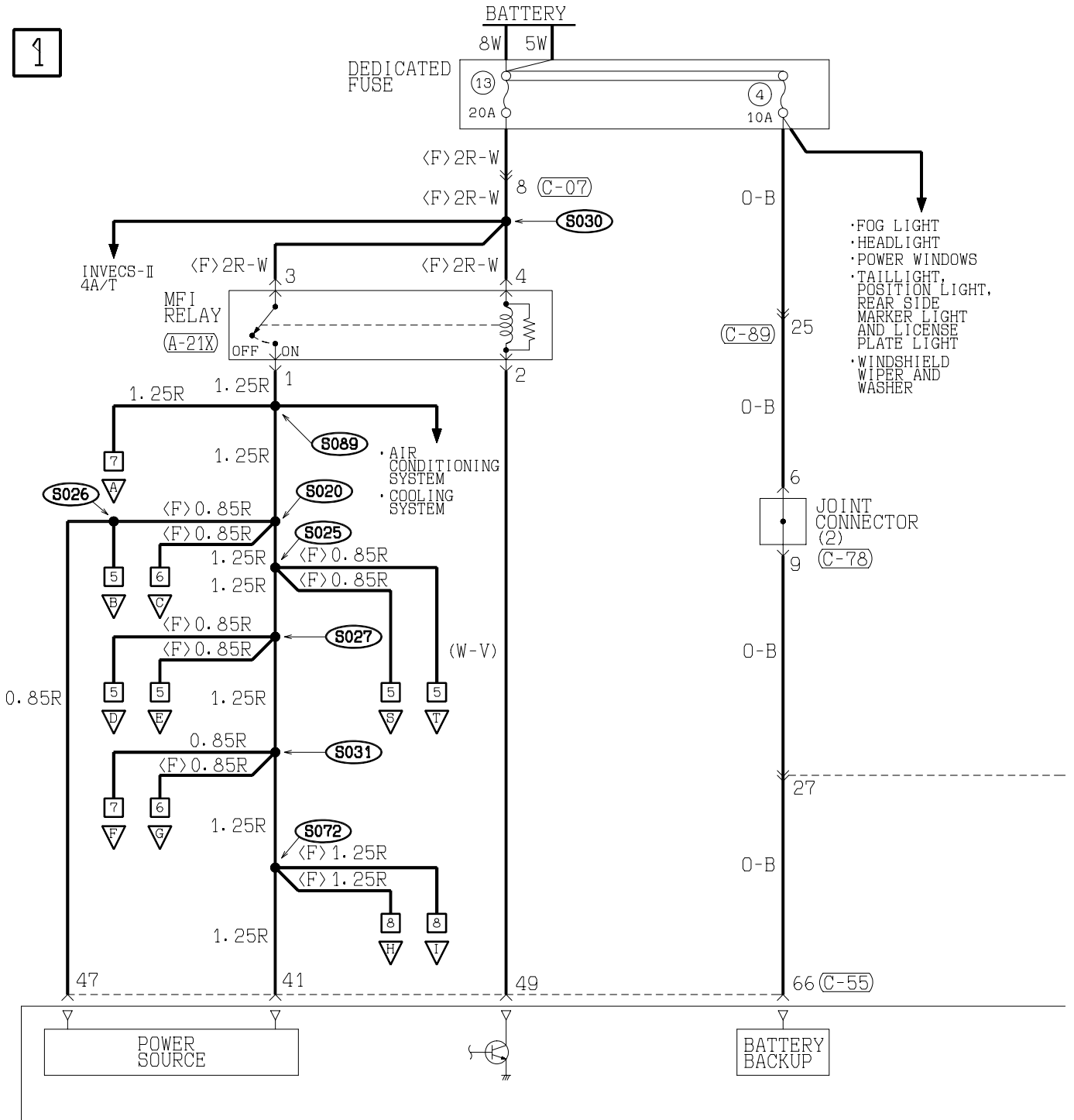

TSB Revision

2

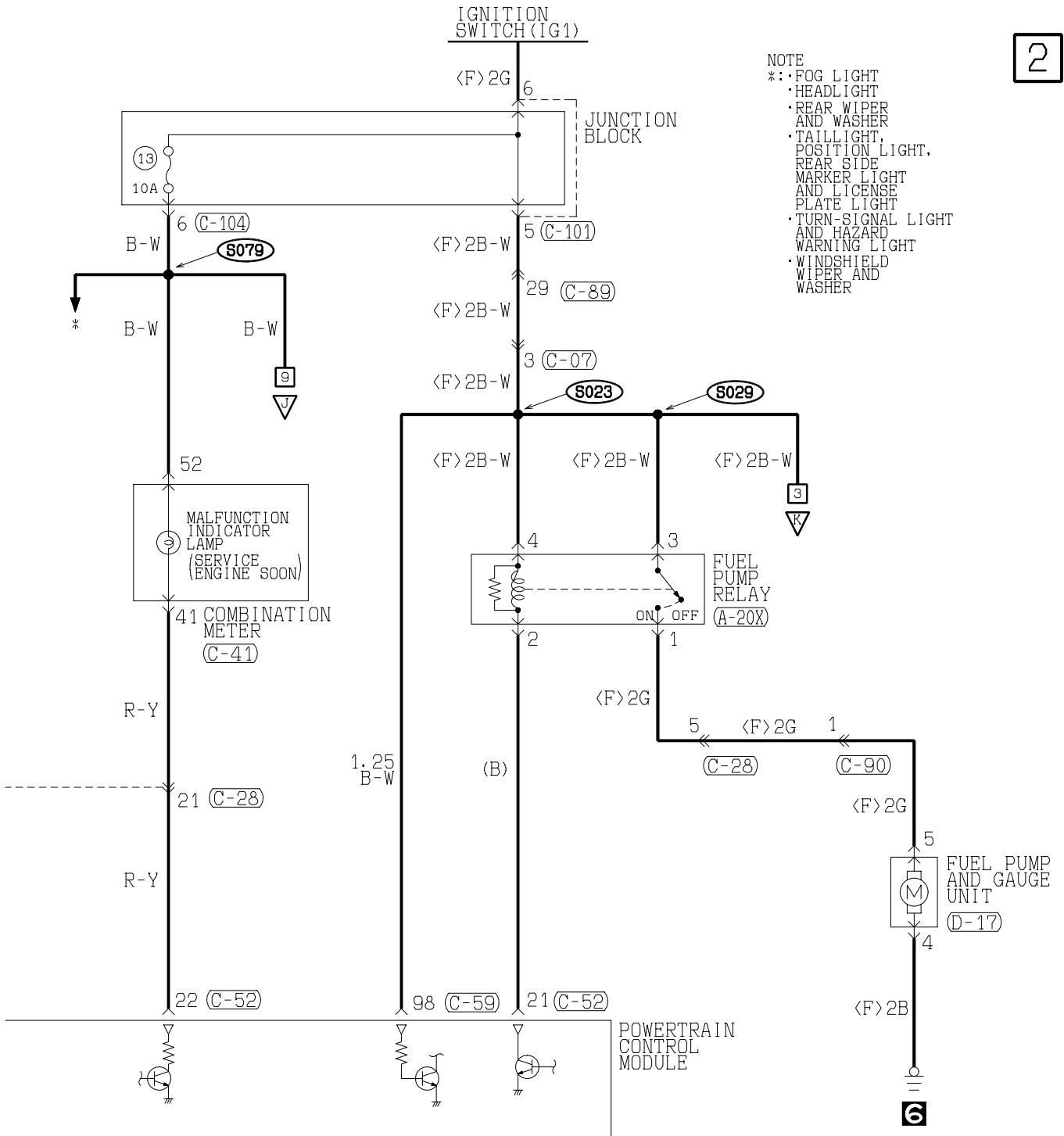

(C-52) (MU803784)

1	2	3	4	5	6	7	8							
9	10	11	12	13	14	15	16	17	18	19	20	21	22	23
24	25	26	27	28	29	30	31	32	33	34	35			

(C-55) (MU803781)

41	42	43	44	45	46					
47	48	49	50	51	52	53	54	55	56	57
58	59	60	61	62	63	64	65	66		

(C-59) (MU803782)

71	72	73	74	75	76	77					
78	79	80	81	82	83	84	85	86	87	88	89
90	91	92	93	94	95	96	97	98			

(C-89)

1	2	3	4	5	6	7	8	9	10	11	12	13
14	15	16	17	18	19	20	21	22	23	24	25	
26	27	28	29	30	31	32	33	34	35	36	37	38

(C-104) (MU801457)

1	2	3	4	5	6	7	8	9		
10	11	12	13	14	15	16	17	18	19	20

(D-17) (MU802058)

1	2	3
4	5	6

WIRE COLOR CODE

B : BLACK BR: BROWN G : GREEN GR: GRAY

L : BLUE LG: LIGHT GREEN O : ORANGE P : PINK

R : RED SB: SKY BLUE V : VIOLET W : WHITE

Y : YELLOW

H1S05M09AB

TSB Revision

MFI SYSTEM <3.0L ENGINE-A/T> (CONTINUED)

3

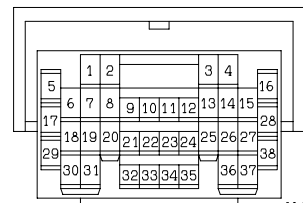
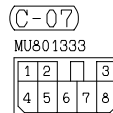
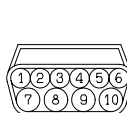
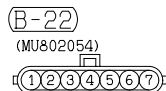
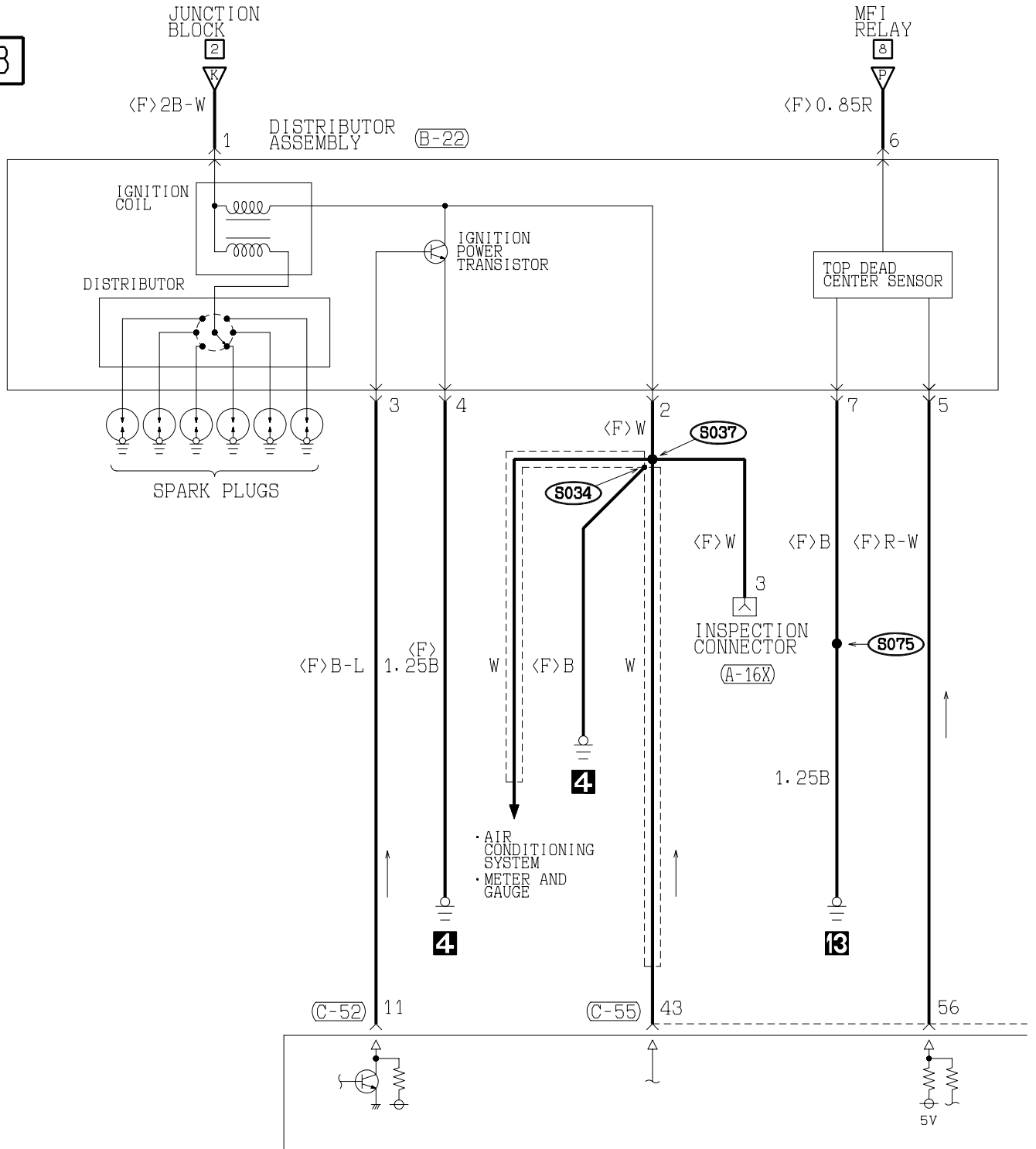

H1S05M09BA

TSB Revision

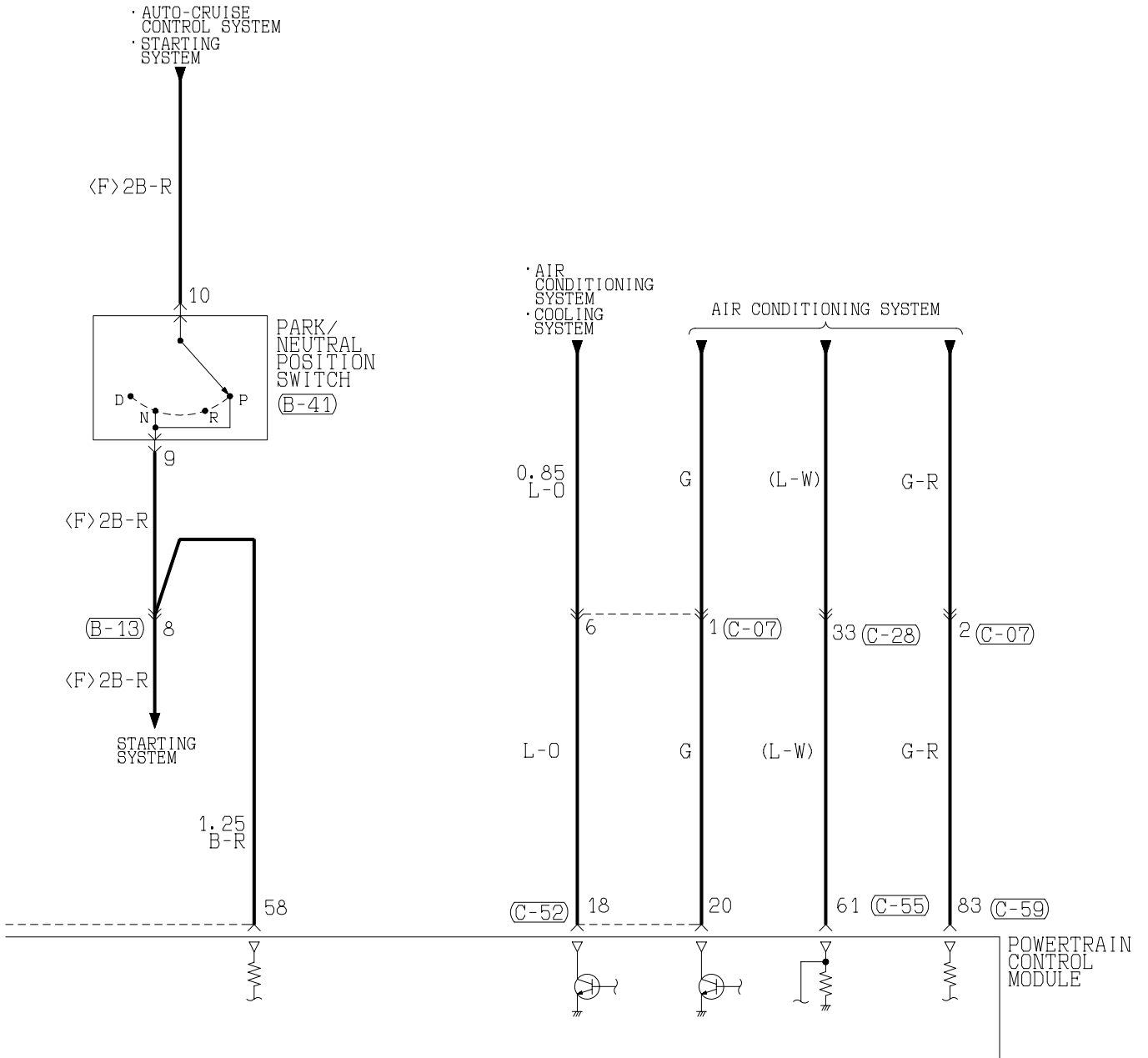

(C-52) (MU803784)

1	2	3	4	5	6	7	8							
9	10	11	12	13	14	15	16	17	18	19	20	21	22	23
24	25	26	27	28	29	30	31	32	33	34	35			

(C-55) (MU803781)

41	42	43	44	45	46					
47	48	49	50	51	52	53	54	55	56	57
58	59	60	61	62	63	64	65	66		

(C-59) (MU803782)

71	72	73	74	75	76	77					
78	79	80	81	82	83	84	85	86	87	88	89
90	91	92	93	94	95	96	97	98			

WIRE COLOR CODE

B : BLACK BR : BROWN G : GREEN GR : GRAY L : BLUE LG : LIGHT GREEN O : ORANGE  
P : PINK R : RED SB : SKY BLUE V : VIOLET W : WHITE Y : YELLOW

H1S05M09BB

MFI SYSTEM <3.0L ENGINE-A/T> (CONTINUED)

5

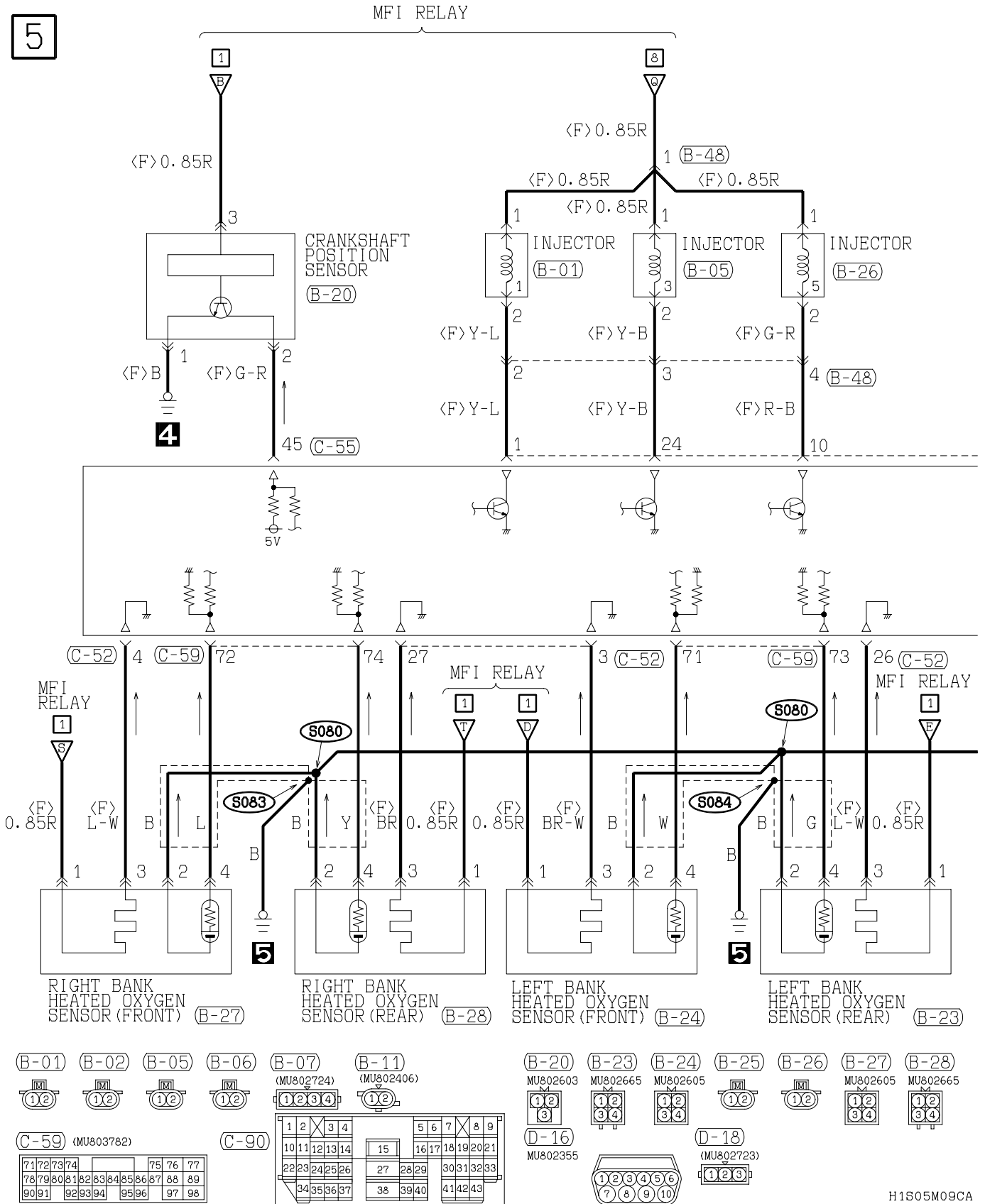

H1S05M09CA

6

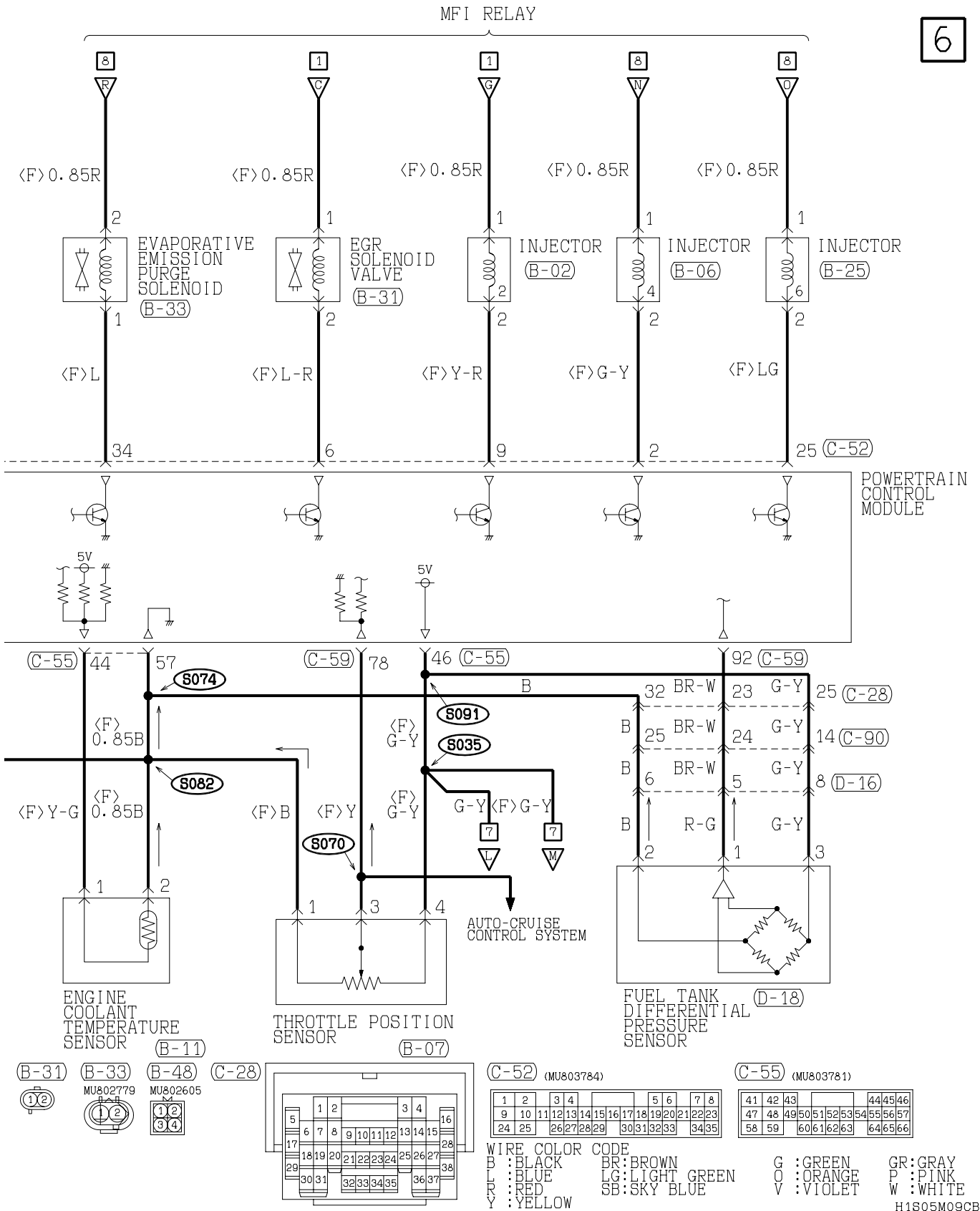

**TSB Revision**

MFI SYSTEM <3.0L ENGINE-A/T> (CONTINUED)

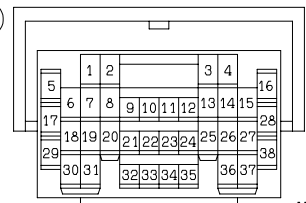
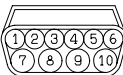
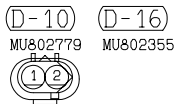
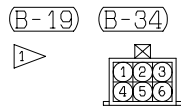
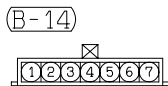
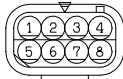
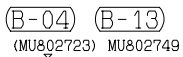
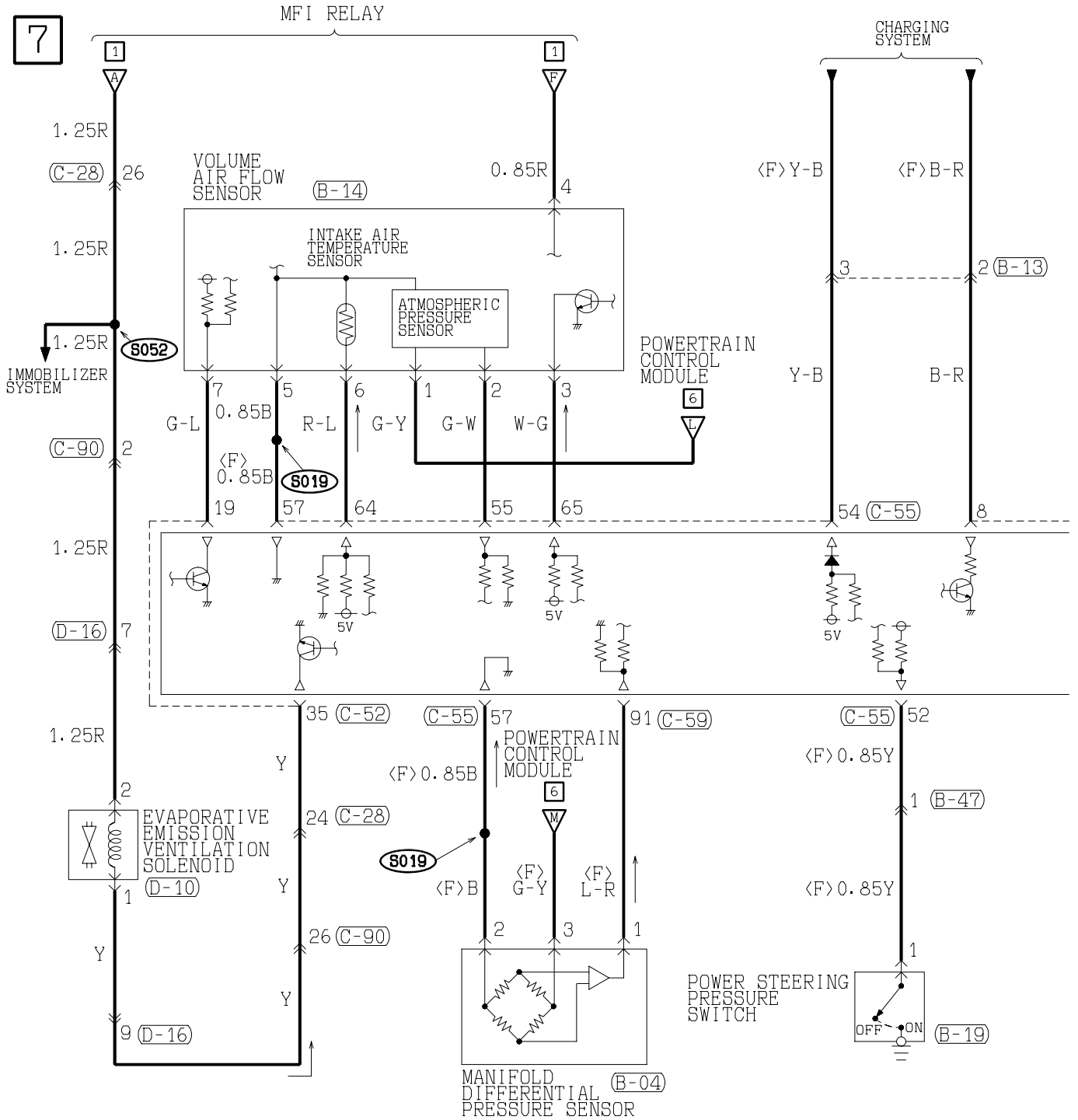

H1805M09DA



8

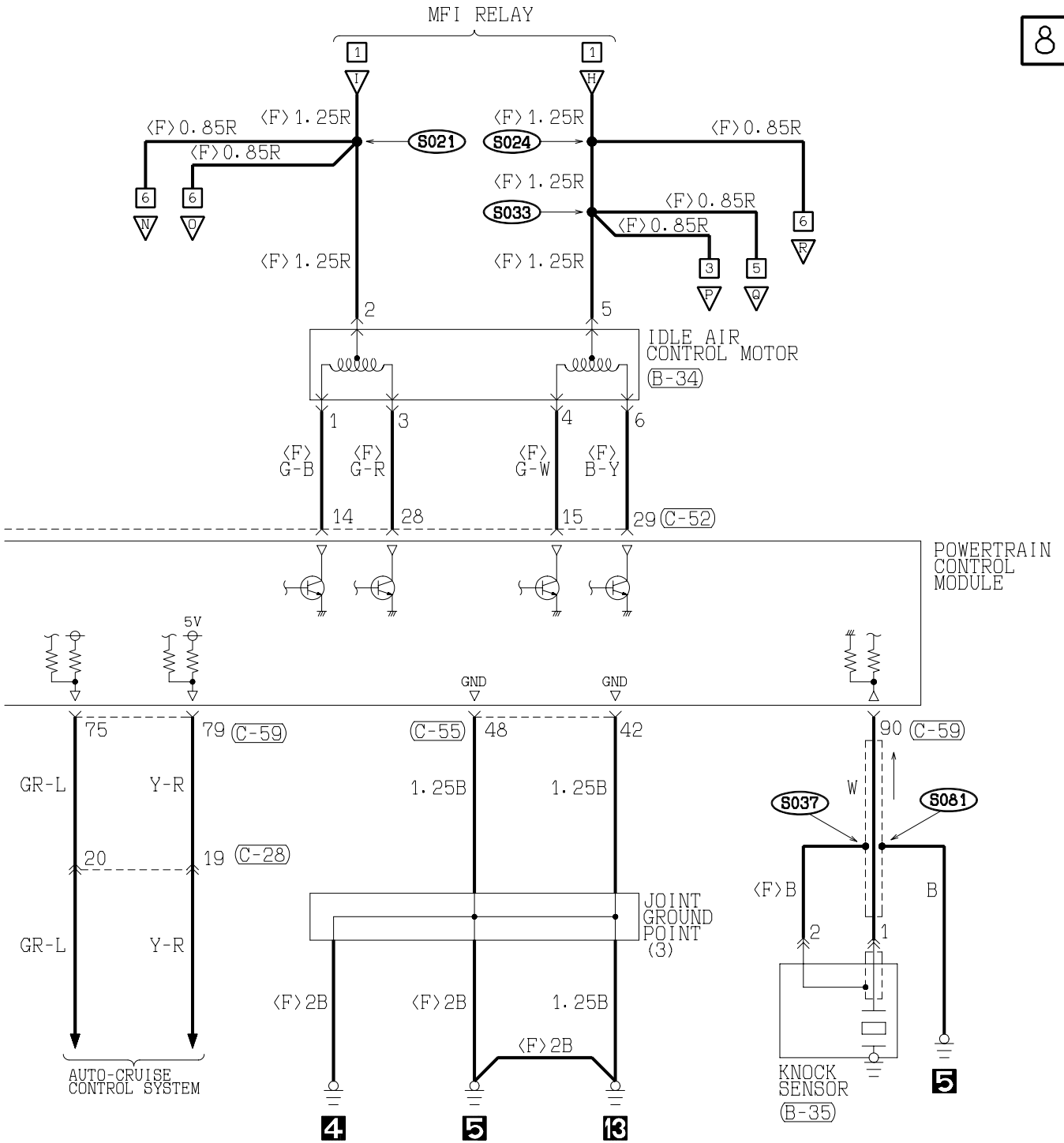

(C-52) (MU803784)

1	2	3	4	5	6	7	8							
9	10	11	12	13	14	15	16	17	18	19	20	21	22	23
24	25	26	27	28	29	30	31	32	33	34	35			

WIRE COLOR CODE  
B : BLACK LG : LIGHT GREEN  
BR : BROWN O : ORANGE  
W : WHITE SB : SKY BLUE  
V : VIOLET

(C-55) (MU803781)

41	42	43	44	45	46					
47	48	49	50	51	52	53	54	55	56	57
58	59	60	61	62	63	64	65	66		

G : GREEN L : BLUE  
GR : GRAY R : RED  
P : PINK Y : YELLOW

(C-59) (MU803782)

71	72	73	74	75	76	77					
78	79	80	81	82	83	84	85	86	87	88	89
90	91	92	93	94	95	96	97	98			

(C-90)

1	2	3	4	5	6	7	8	9			
10	11	12	13	14	15	16	17	18	19	20	21
22	23	24	25	26	27	28	29	30	31	32	33
34	35	36	37	38	39	40	41	42	43		

H1S05M09DB

TSB Revision

MFI SYSTEM <3.0L ENGINE-A/T> (CONTINUED)

9

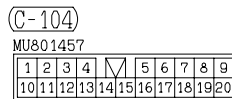
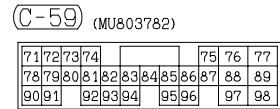
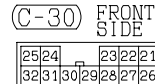
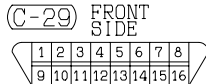
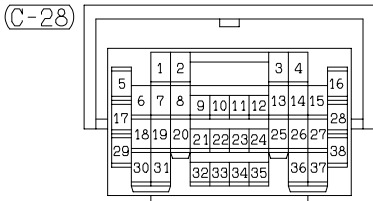
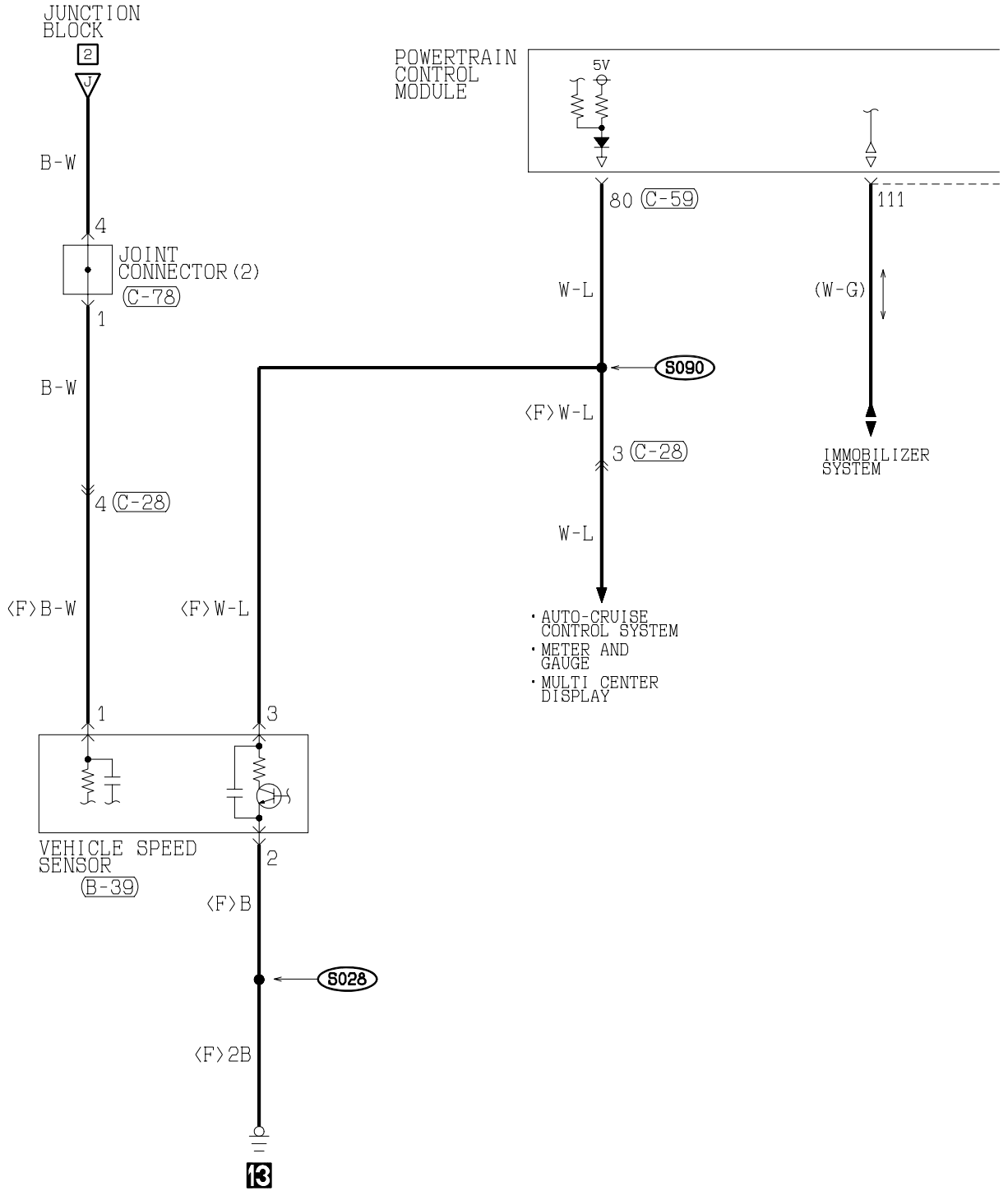

TSB Revision

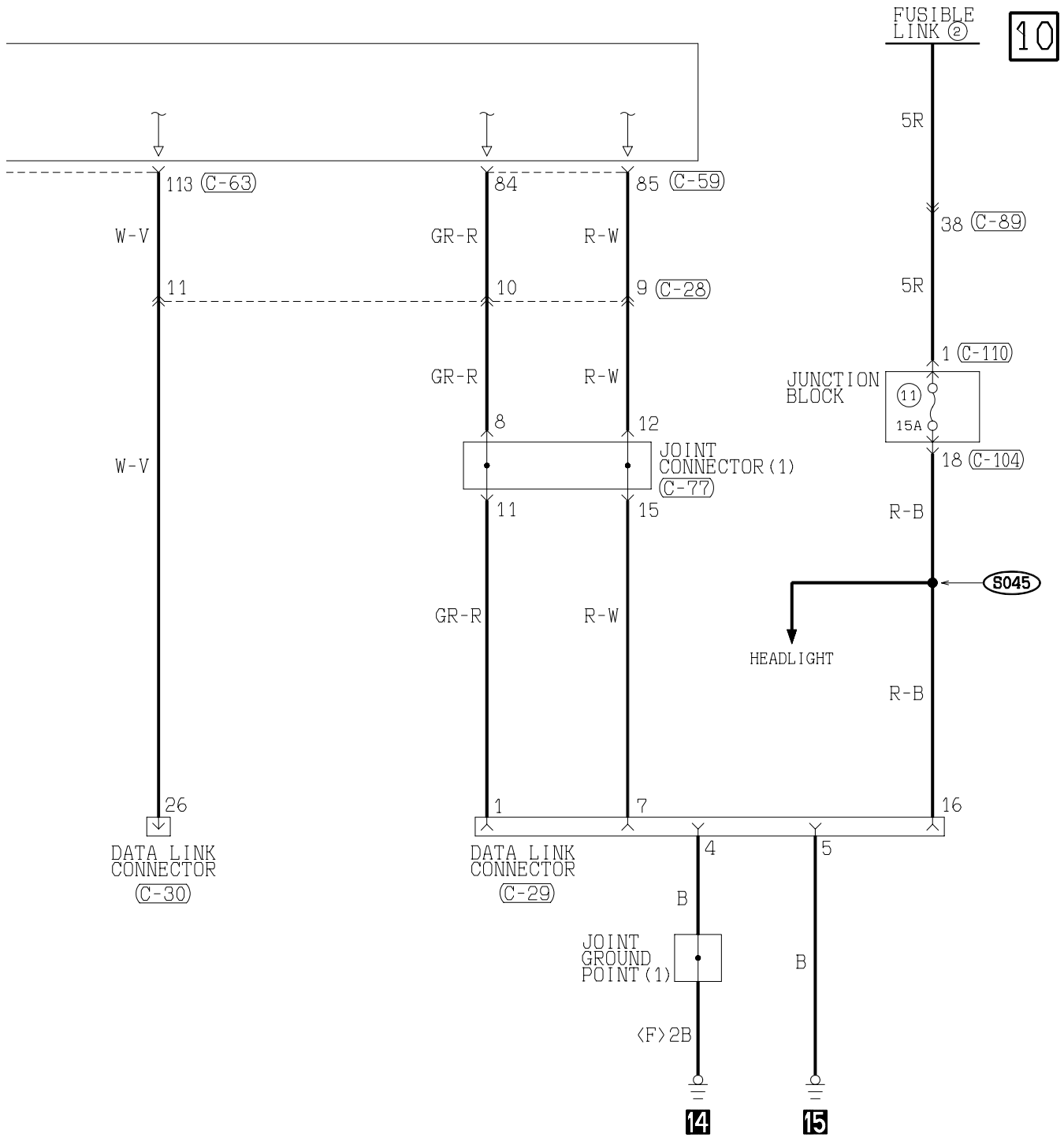

(C-63) (MU803783)

101	102	103	104	105	106	107
108	109	110	111	112	113	114
115	116	117	118	119	120	
121	122	123	124	125	126	127
128	129	130				

(C-77)

1	2	3	4	5	6	7	8	9	10	11
12	13	14	15	16	17	18	19	20	21	22
23	24	25	26	27	28	29	30	31	32	33

(C-78)

1	2	3	4	5	6	7	8	9	10	11
12	13	14	15	16	17	18	19	20	21	22
23	24	25	26	27	28	29	30	31	32	33

(C-89)

1	2	3	4	5	6	7	8	9	10	11	12	13
14	15	16	17	18	19	20	21	22	23	24	25	
26	27	28	29					30	31			
32	33	34						36	37			
											38	

WIRE COLOR CODE  
B : BLACK BR : BROWN  
P : PINK R : RED

G : GREEN SB : SKY BLUE

GR : GRAY V : VIOLET

L : BLUE W : WHITE

LG : LIGHT GREEN Y : YELLOW

O : ORANGE

TSB Revision

# COOLING SYSTEM <2.4L ENGINE>

M1901001000056

1

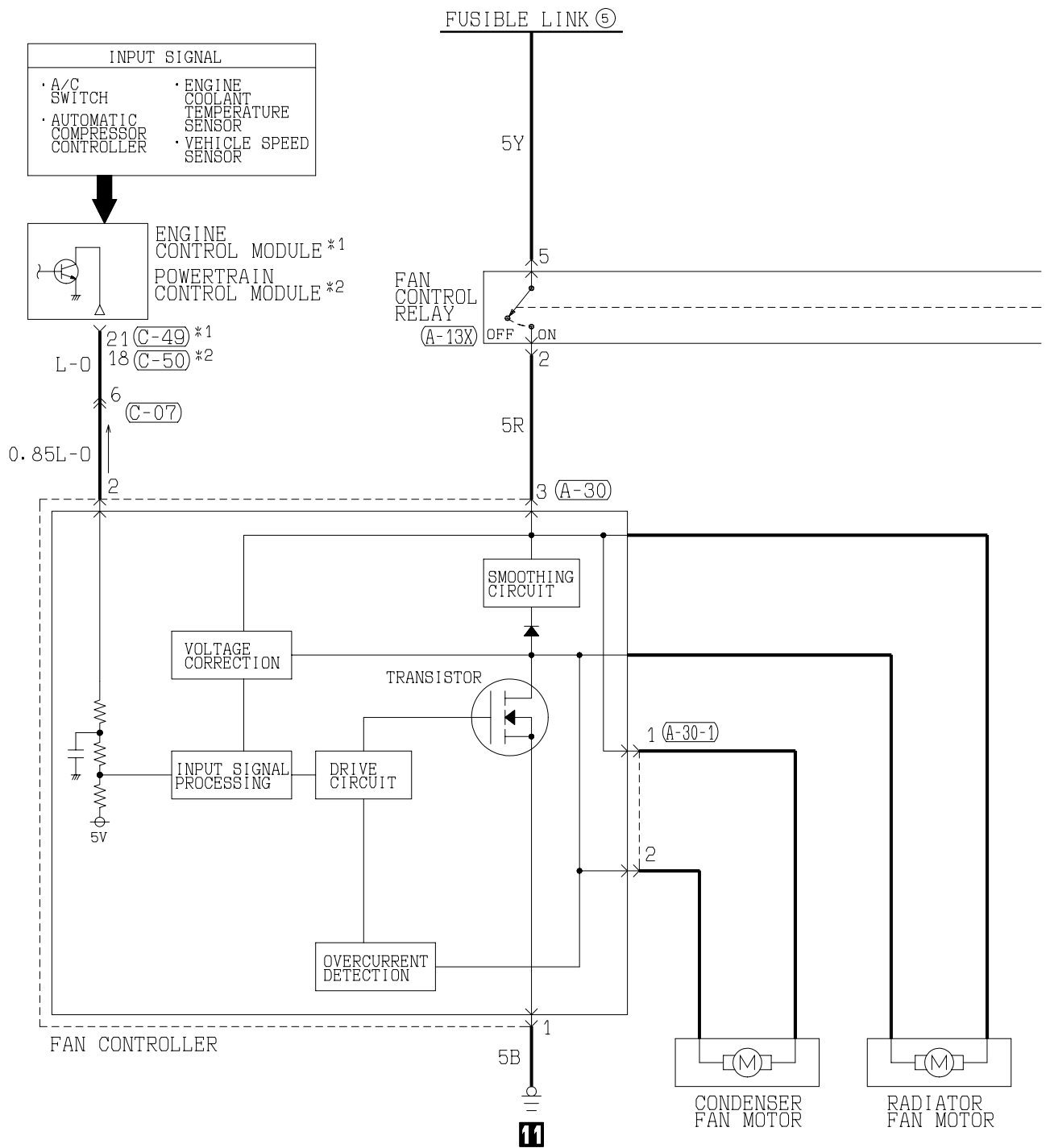

(A-13X)

(A-21X)

(A-30) (MU802322)

(A-30-1) (1)(2)

(C-07) MU801333

(C-49) (MU803773)

(C-50) (MU803784)

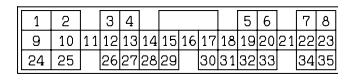
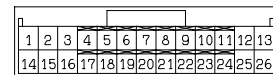

H1S06M03AA

TSB Revision



COOLING SYSTEM <3.0L ENGINE>

M1901001000067

1

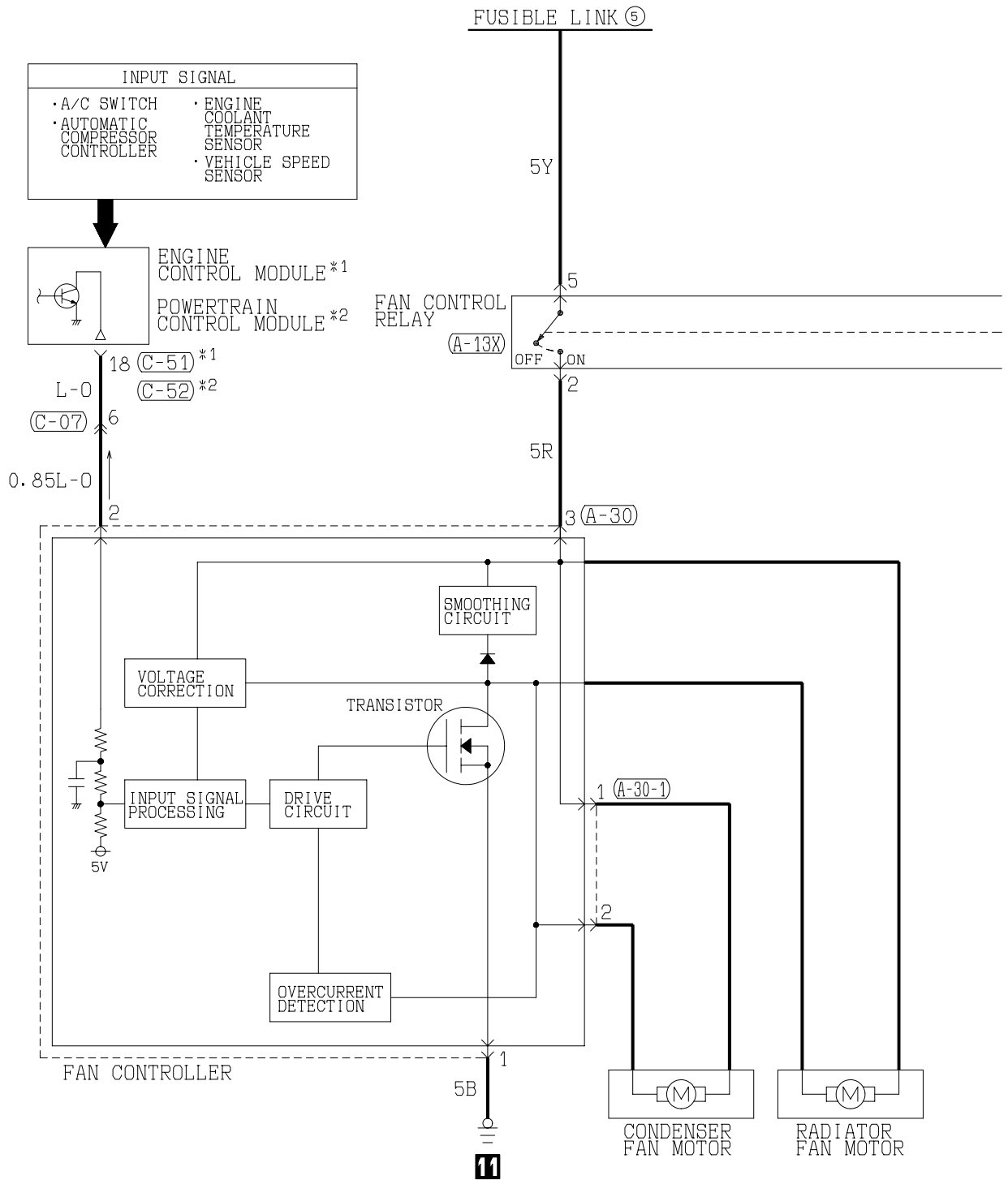

(A-13X)



(A-21X)



(A-30)



(A-30-1)



(C-07)



(C-51) (MU803784)

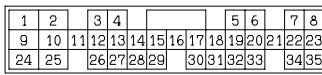

(C-52) (MU803784)

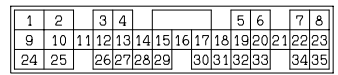

H1S06M04AA

TSB Revision



# INVECS-II 4A/T <VEHICLES WITHOUT SPORT MODE TYPE>

M1901016200078

1

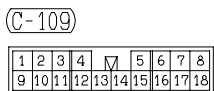
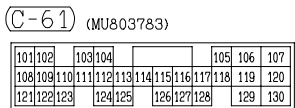
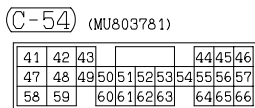
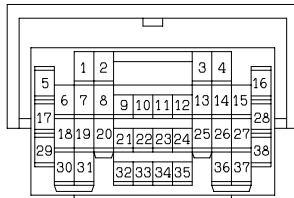
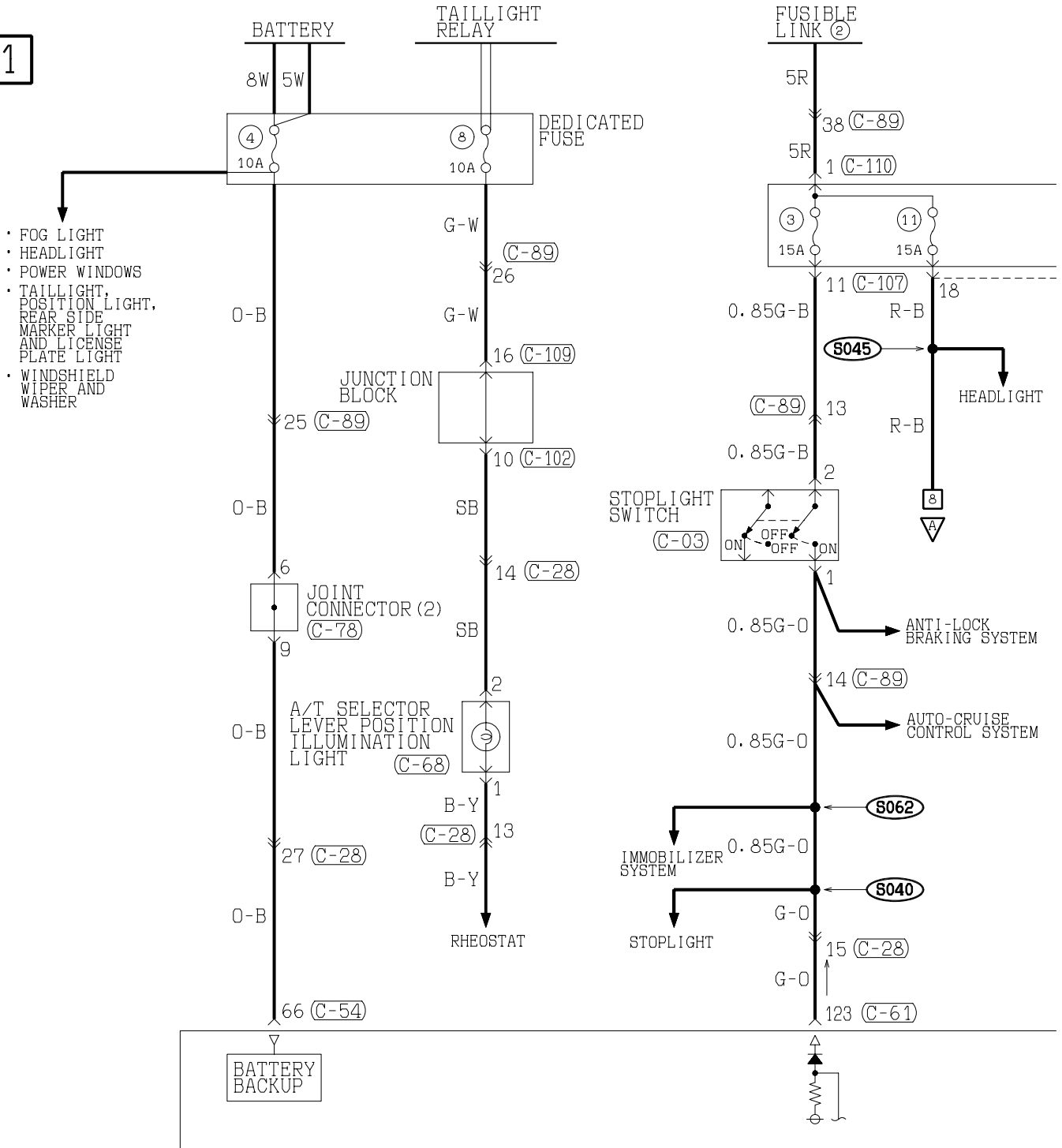

H1S07M04AA

TSB Revision



2

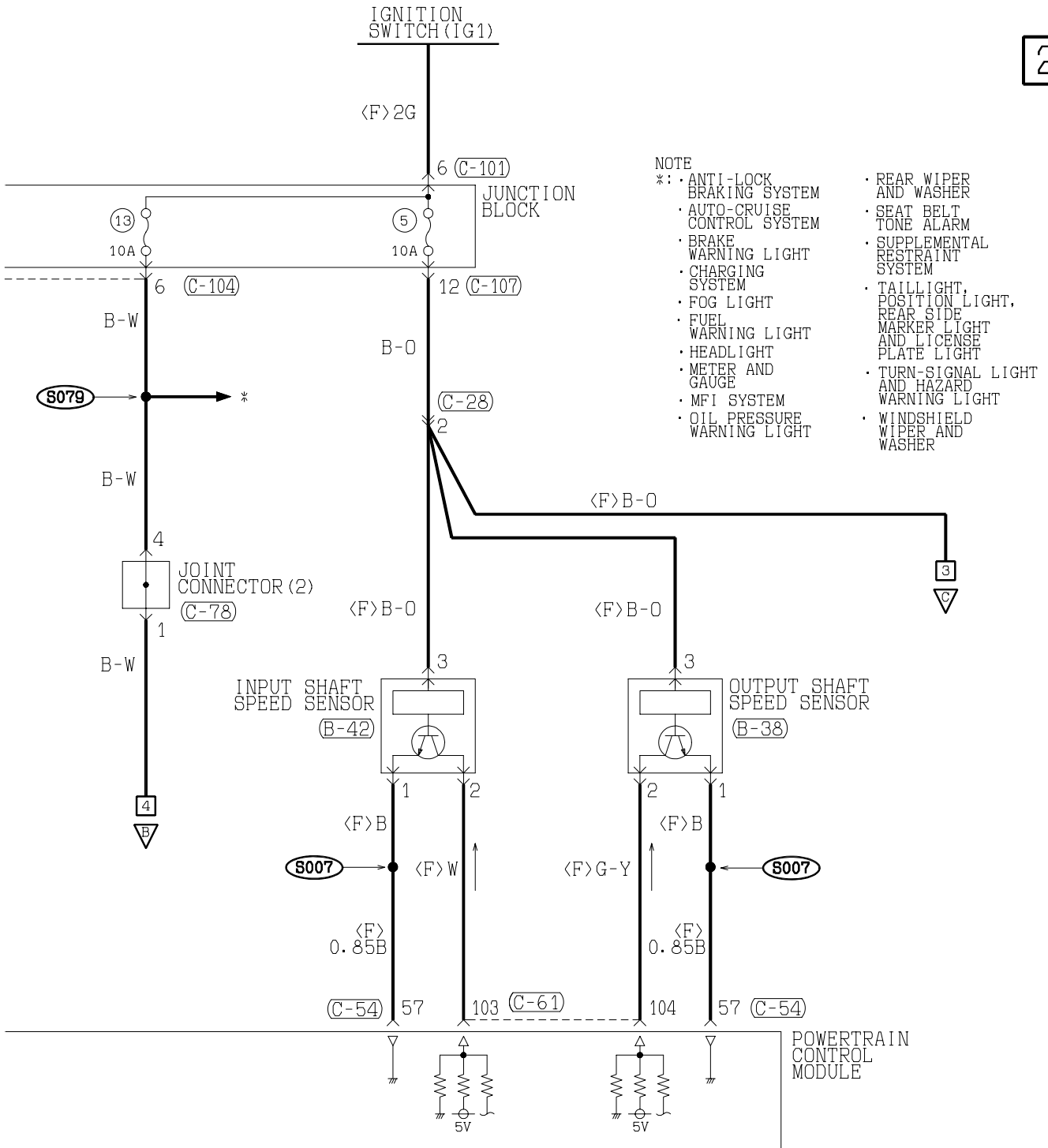

(C-78)

1	2	3	4	5	6	7	8	9	10	11
12	13	14	15	16	17	18	19	20	21	22
23	24	25	26	27	28	29	30	31	32	33

(C-89)

1	2	3	4	5	6	7	8	9	10	11	12	13
14	15	16	17	18	19	20	21	22	23	24	25	
26	27	28	29			30	31					
32	33	34		35		36	37					
											38	

(C-101)

1	2	3
4	5	6

(C-102)

1	2	3	4
5	6	7	8
9	10		

(C-104)

1	2	3	4	5	6	7	8	9
10	11	12	13	14	15	16	17	18
19	20							

(C-107)

1	2	3	4	5	6	7	8	9	10
11	12	13	14	15	16	17	18	19	20
21	22								

**WIRE COLOR CODE**

B : BLACK	BR : BROWN	G : GREEN	GR : GRAY
L : BLUE	LG : LIGHT GREEN	O : ORANGE	P : PINK
R : RED	SB : SKY BLUE	V : VIOLET	W : WHITE
Y : YELLOW			

H1S07M04AB

**TSB Revision**

INVECS-II 4A/T <VEHICLES WITHOUT SPORT MODE TYPE> (CONTINUED)

3

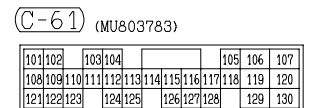
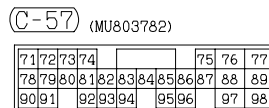
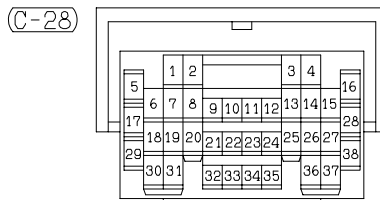
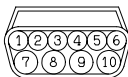
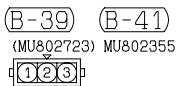
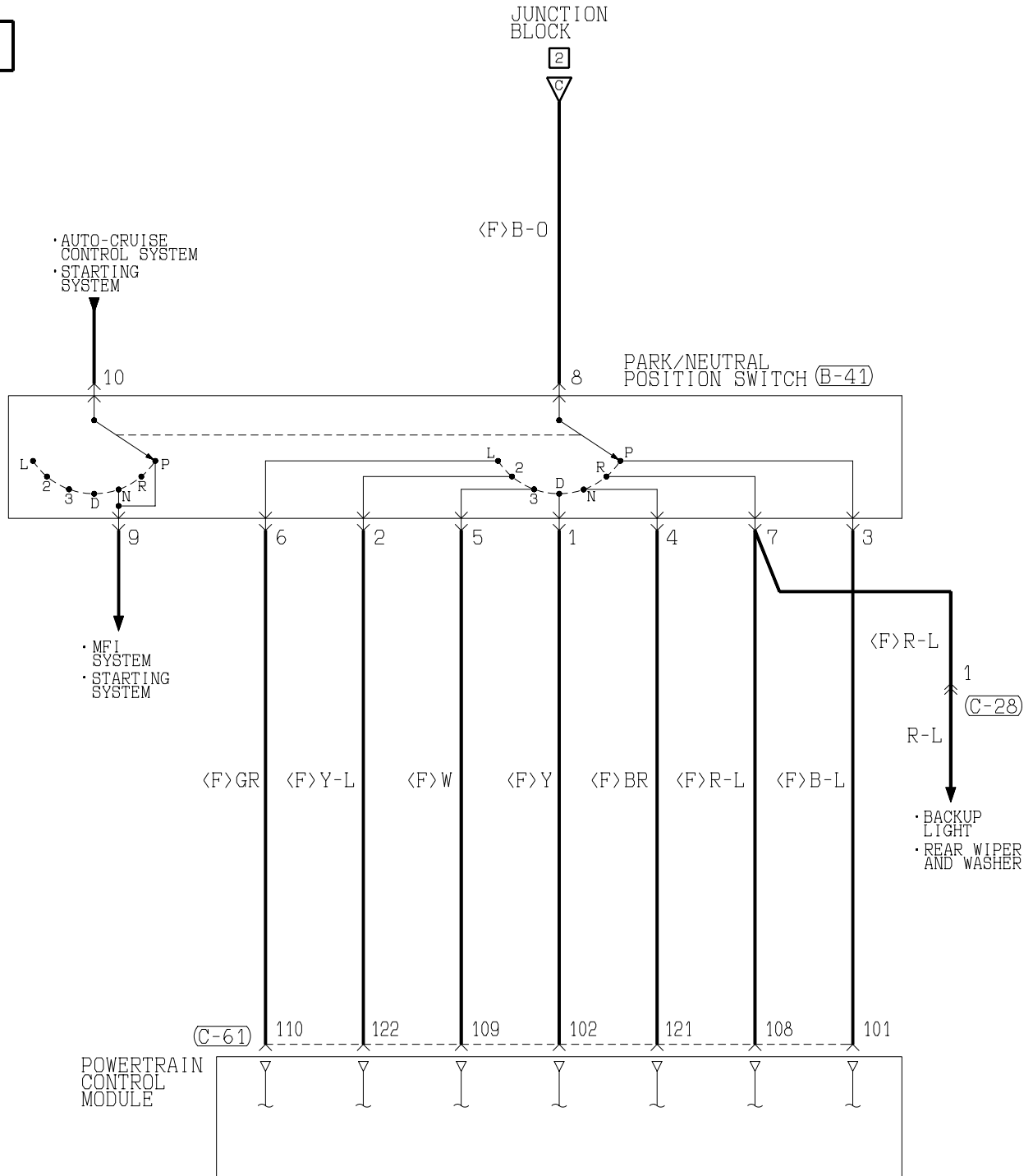

H1S07M04BA

TSB Revision

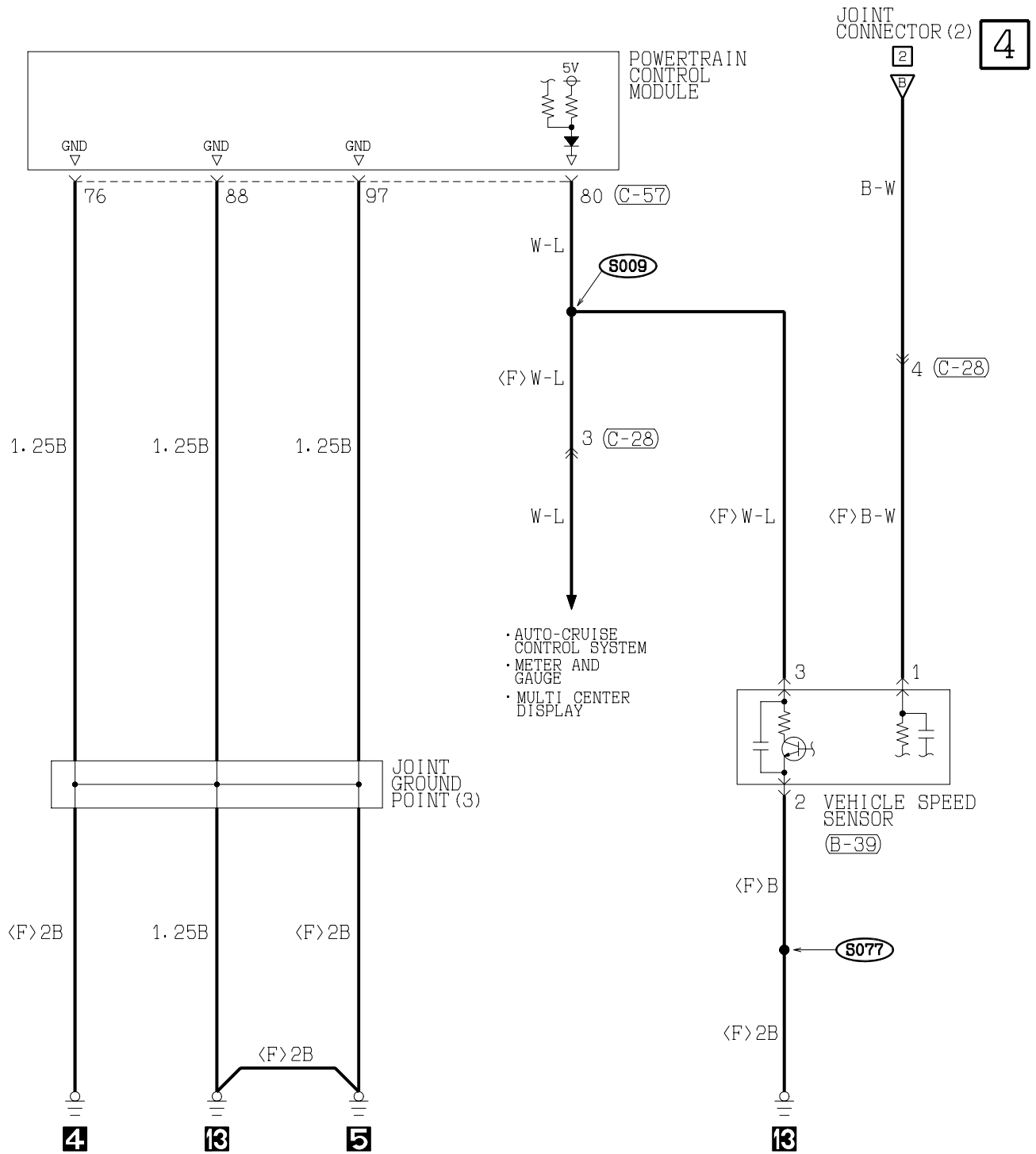

WIRE COLOR CODE  
 B :BLACK BR: BROWN G : GREEN GR: GRAY L : BLUE LG: LIGHT GREEN O : ORANGE  
 P : PINK R : RED SB: SKY BLUE V : VIOLET W : WHITE Y : YELLOW

H1S07M04BB

**TSB Revision**

INVECS-II 4A/T <VEHICLES WITHOUT SPORT MODE TYPE> (CONTINUED)

5

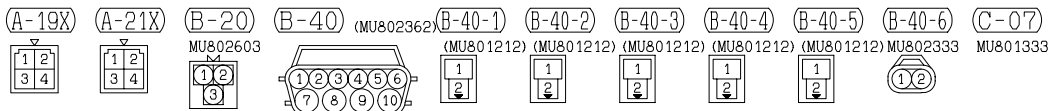
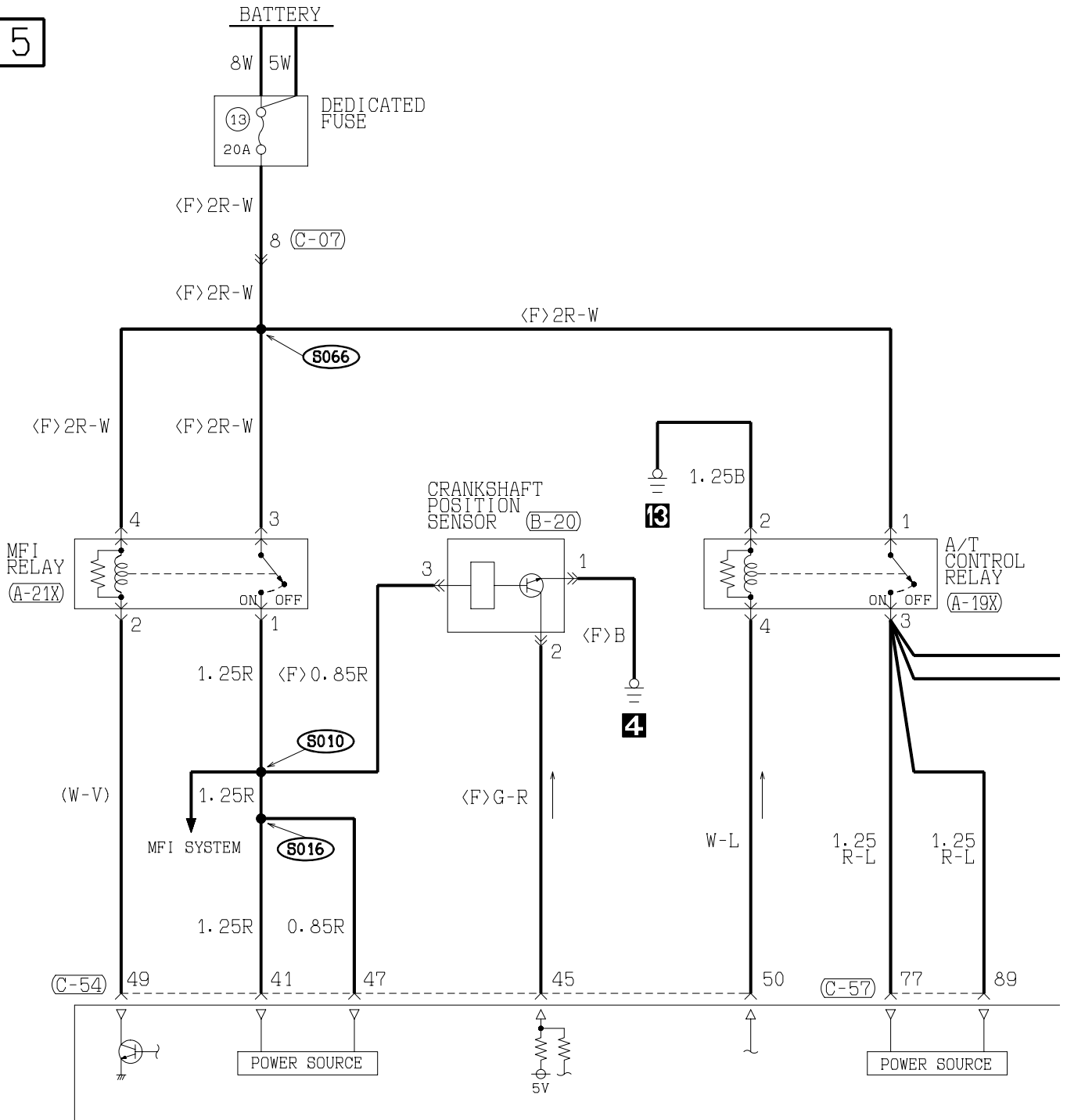

TSB Revision

6

**NOTE**

- \*1: UNDERDRIVE SOLENOID VALVE
- \*2: SECOND SOLENOID VALVE
- \*3: OVERDRIVE SOLENOID VALVE
- \*4: TORQUE CONVERTER CLUTCH CONTROL SOLENOID VALVE
- \*5: LOW AND REVERSE SOLENOID VALVE

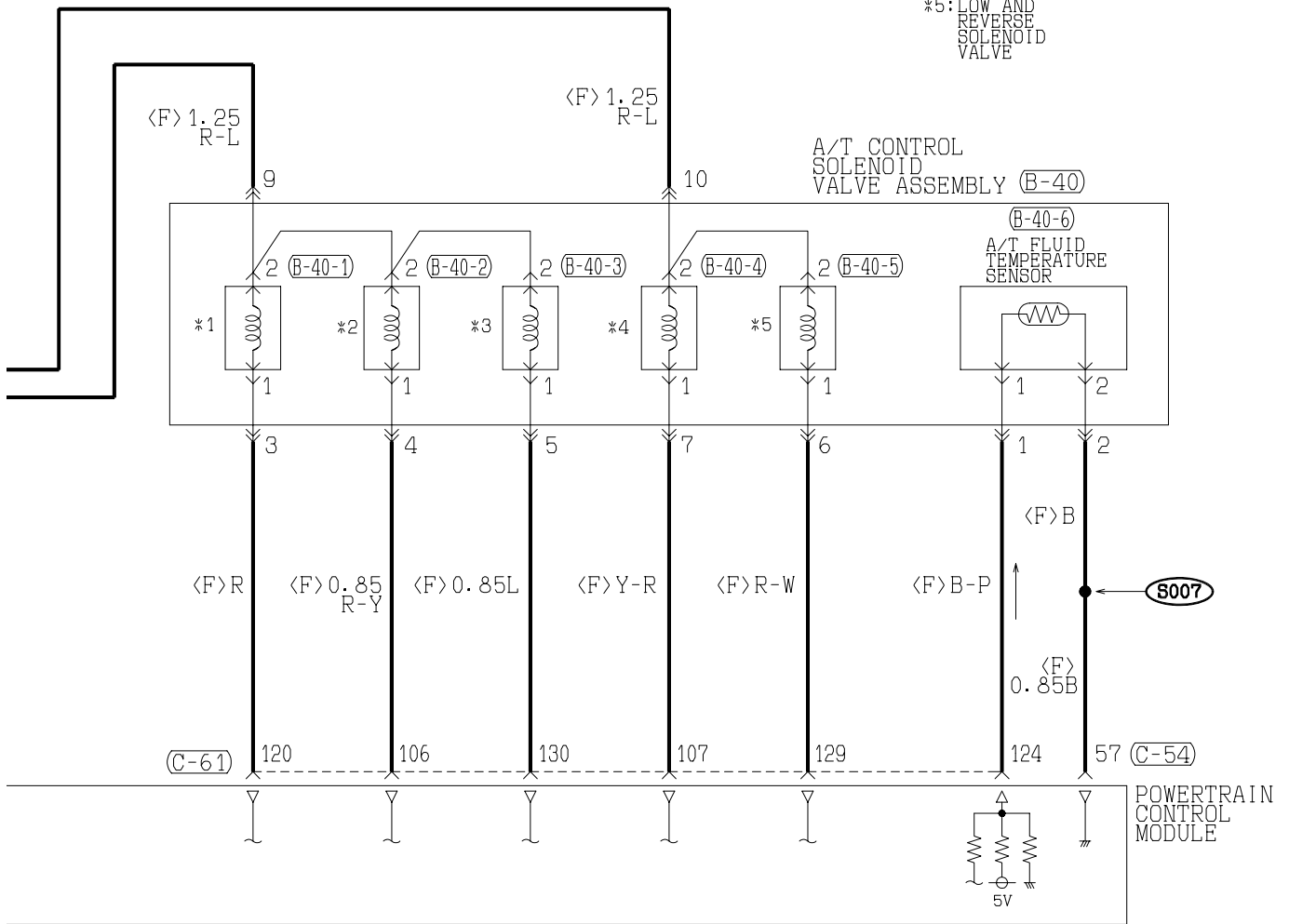

**(C-54)** (MU803781)

41	42	43		44	45	46
47	48	49	50	51	52	53
54	55	56	57			
58	59	60	61	62	63	64
65	66					

**(C-57)** (MU803782)

71	72	73	74		75	76	77
78	79	80	81	82	83	84	85
86	87	88	89				
90	91	92	93	94	95	96	97
98							

**(C-61)** (MU803783)

101	102	103	104		105	106	107
108	109	110	111	112	113	114	115
116	117	118	119	120			
121	122	123	124	125	126	127	128
129	130						

**WIRE COLOR CODE**

- B : BLACK
- BR : BROWN
- G : GREEN
- GR : GRAY
- L : BLUE
- LG : LIGHT GREEN
- O : ORANGE
- P : PINK
- R : RED
- SB : SKY BLUE
- V : VIOLET
- W : WHITE
- Y : YELLOW

H1S07M04CB

**TSB Revision**

INVECS-II 4A/T <VEHICLES WITHOUT SPORT MODE TYPE> (CONTINUED)

7

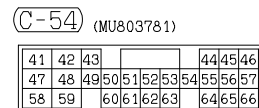
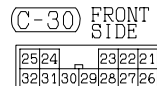
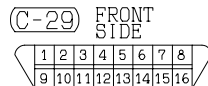
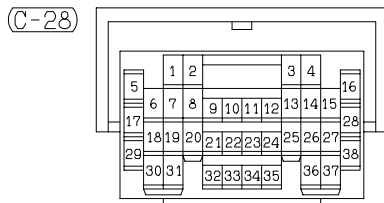
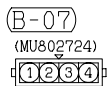
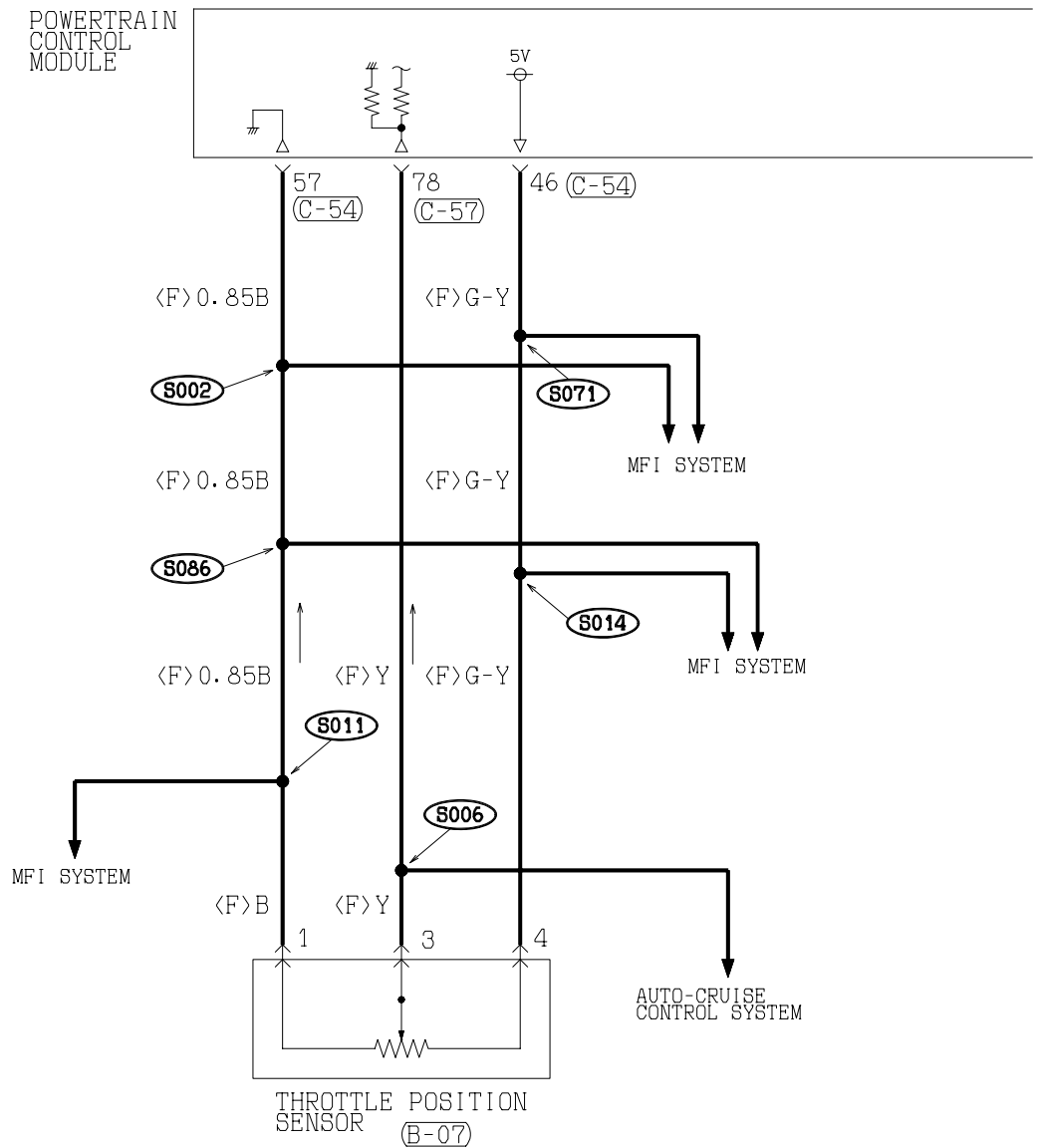

TSB Revision

8

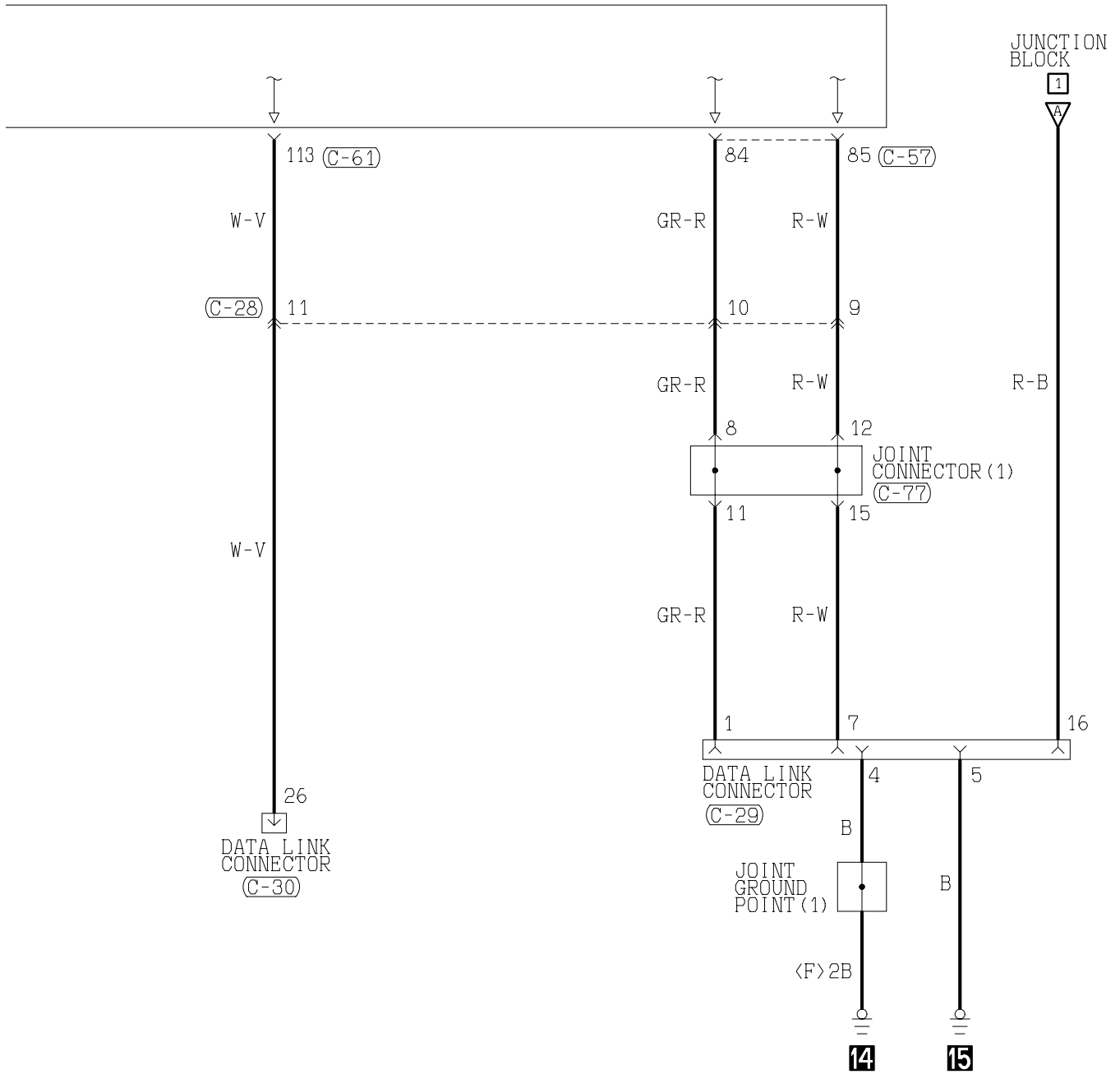

C-57 (MU803782)

71	72	73	74		75	76	77				
78	79	80	81	82	83	84	85	86	87	88	89
90	91	92	93	94	95	96	97	98			

C-61 (MU803783)

101	102	103	104		105	106	107					
108	109	110	111	112	113	114	115	116	117	118	119	120
121	122	123	124	125	126	127	128	129	130			

C-77

1	2	3	4	5	6	7	8	9	10	11
12	13	14	15	16	17	18	19	20	21	22
23	24	25	26	27	28	29	30	31	32	33

WIRE COLOR CODE

B : BLACK BR : BROWN G : GREEN GR : GRAY L : BLUE LG : LIGHT GREEN O : ORANGE  
 P : PINK R : RED SB : SKY BLUE V : VIOLET W : WHITE Y : YELLOW

H1S07M04DB

TSB Revision

# INVECS-II 4A/T <VEHICLES WITH SPORT MODE TYPE (2.4L ENGINE) >

M1901016200089

1

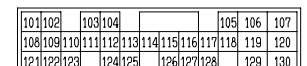
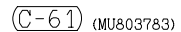
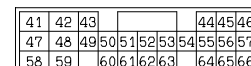
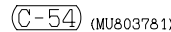
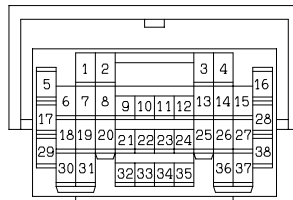
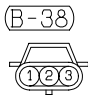
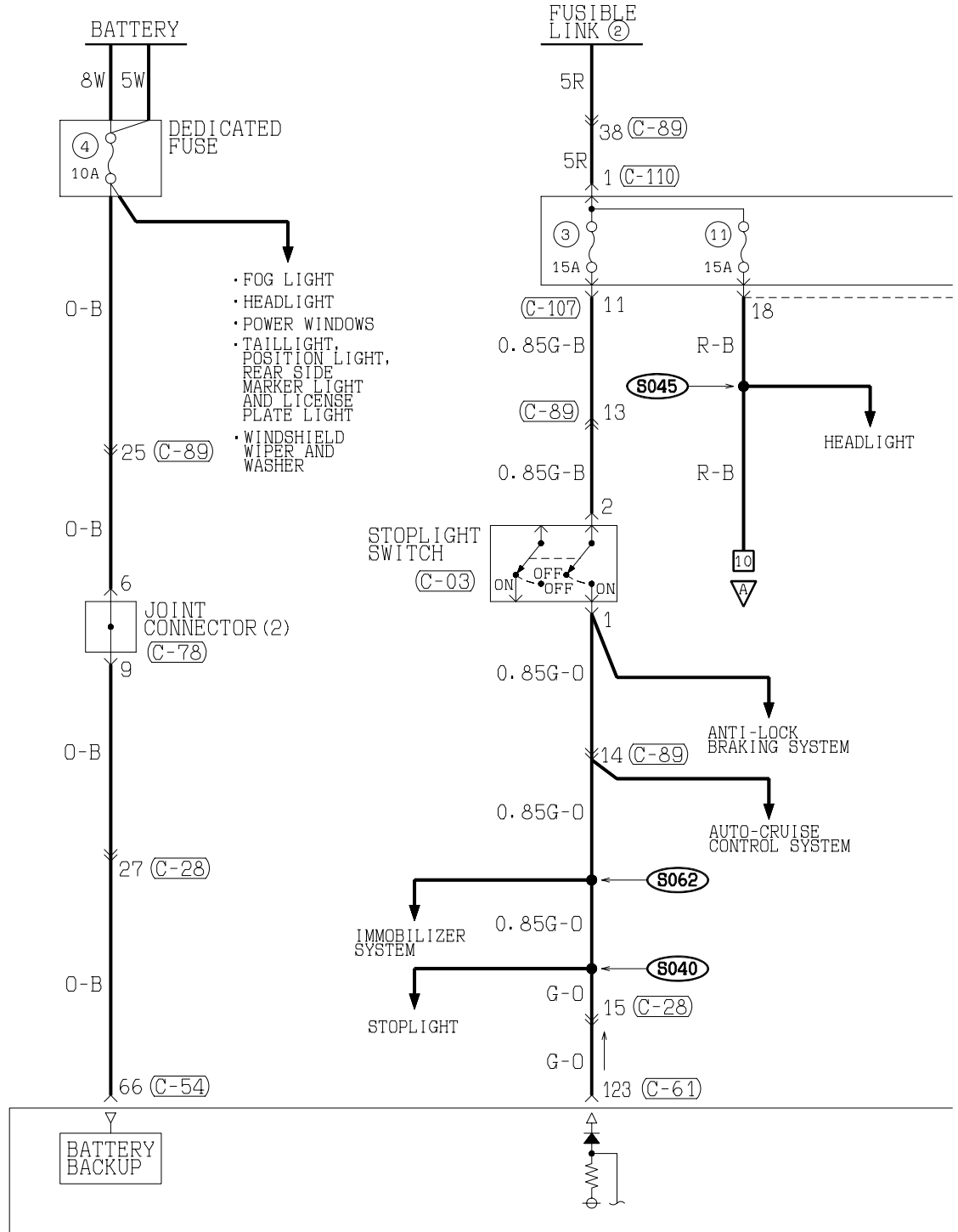

H1S07M03AA

TSB Revision



2

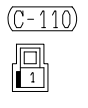
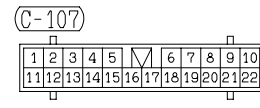
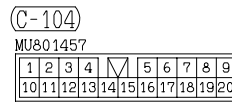
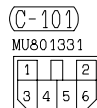
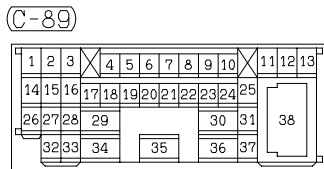
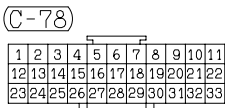
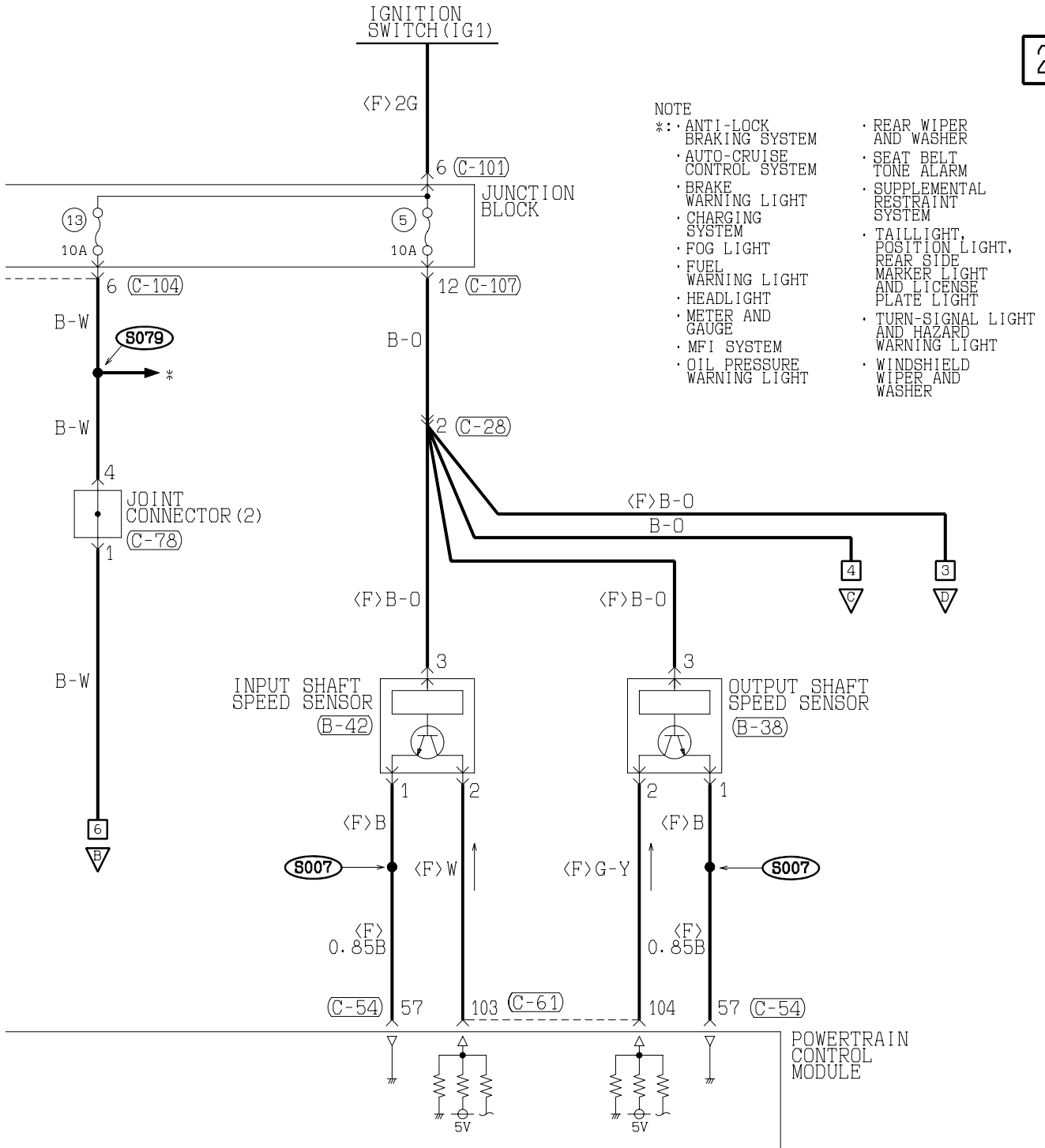

**WIRE COLOR CODE**

B : BLACK	BR : BROWN	G : GREEN	GR : GRAY
L : BLUE	LG : LIGHT GREEN	O : ORANGE	P : PINK
R : RED	SB : SKY BLUE	V : VIOLET	W : WHITE
Y : YELLOW			

H1S07M03AB

**TSB Revision**

INVECS-II 4A/T <VEHICLES WITH SPORT MODE TYPE (2.4L ENGINE) > (CONTINUED)

3

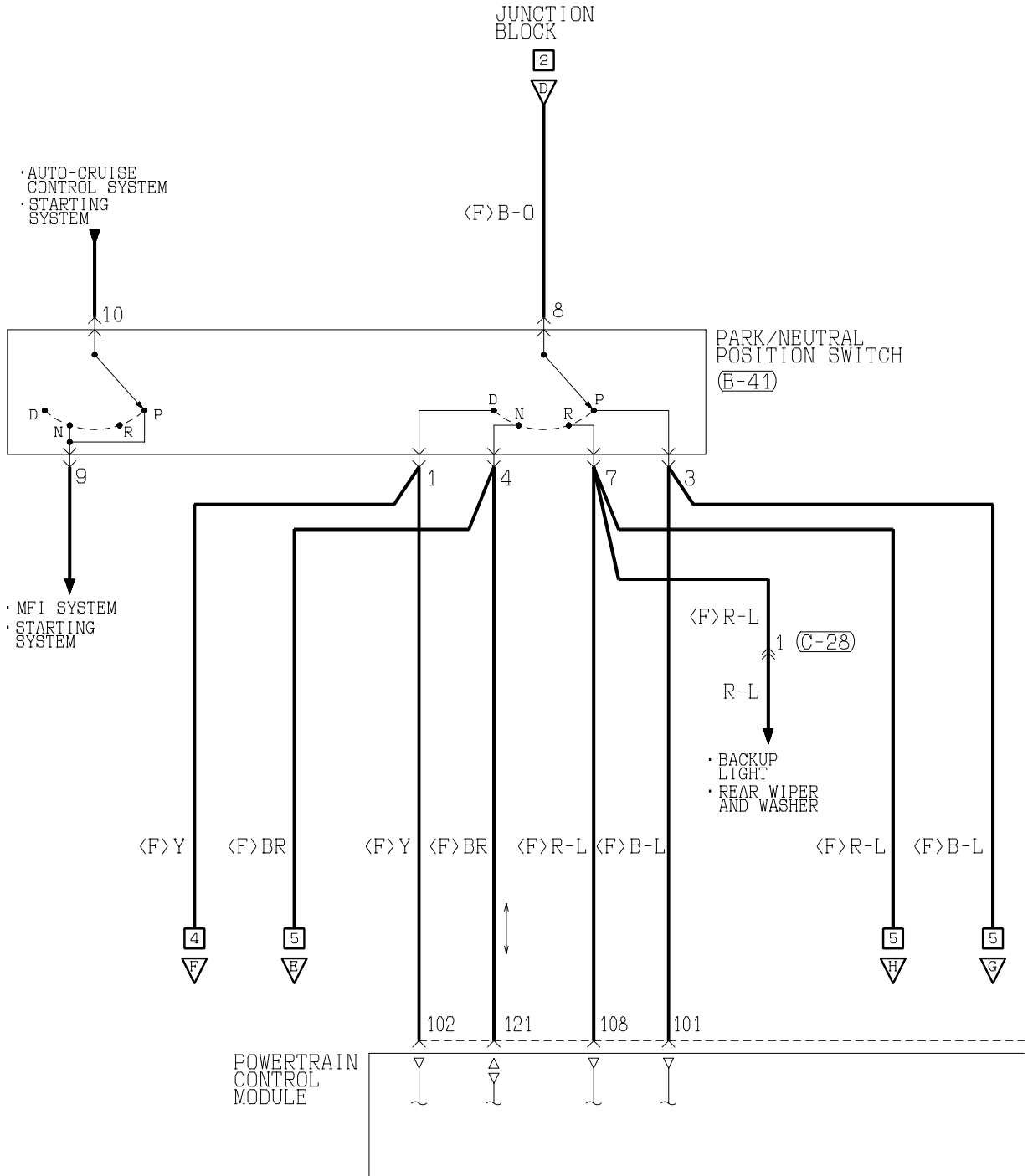

(B-41)  
MU802355

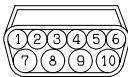

(C-28)

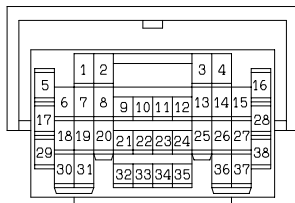

(C-61) (MU803783)

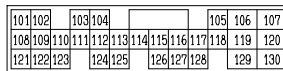

(C-65)



4

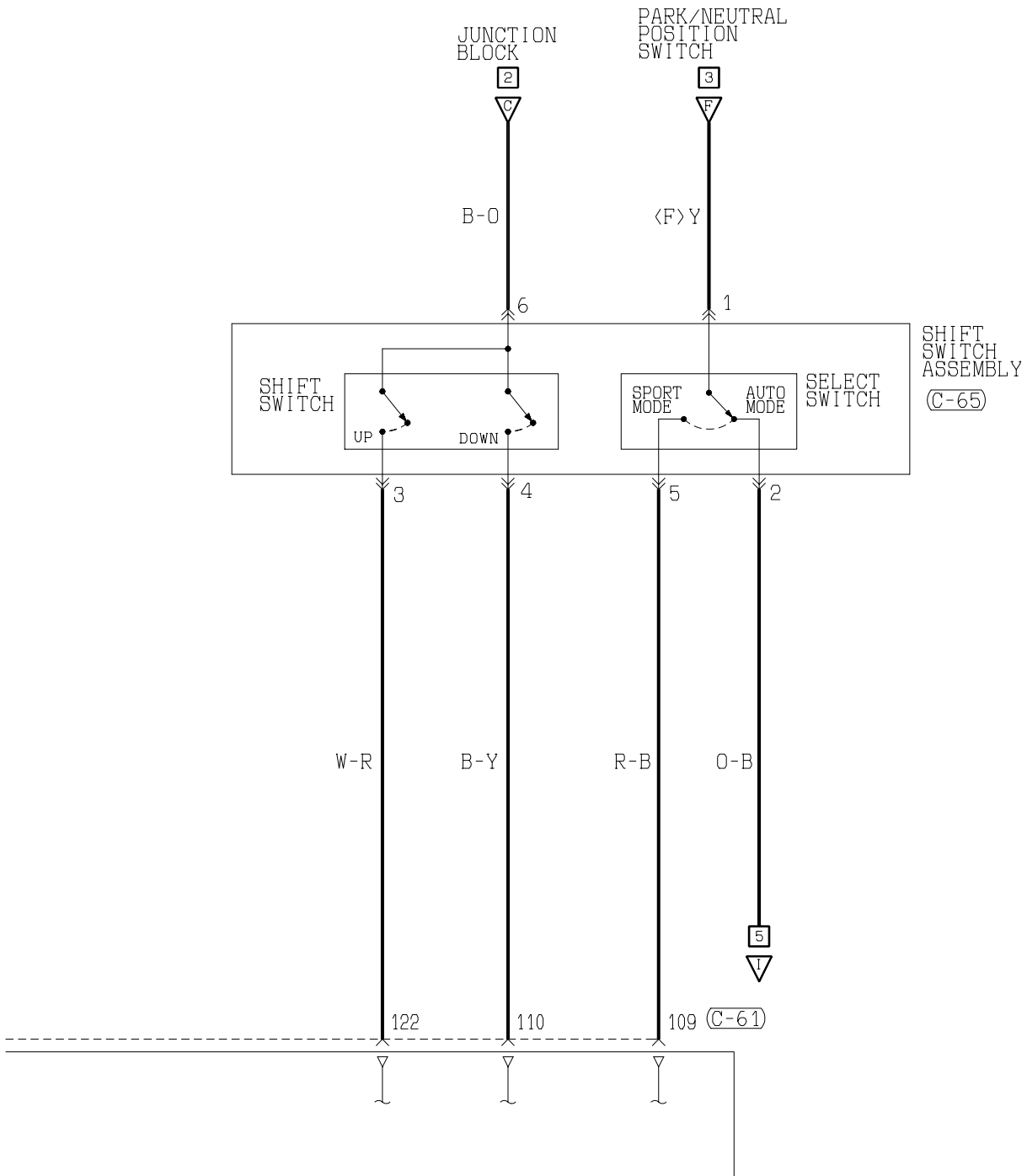

WIRE COLOR CODE  
 B : BLACK BR : BROWN G : GREEN GR : GRAY L : BLUE LG : LIGHT GREEN O : ORANGE  
 P : PINK R : RED SB : SKY BLUE V : VIOLET W : WHITE Y : YELLOW

H1S07M03BB

TSB Revision

INVECS-II 4A/T <VEHICLES WITH SPORT MODE TYPE (2.4L ENGINE) > (CONTINUED)

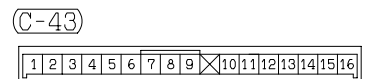
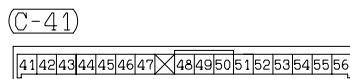
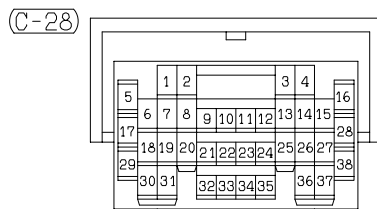
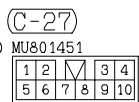
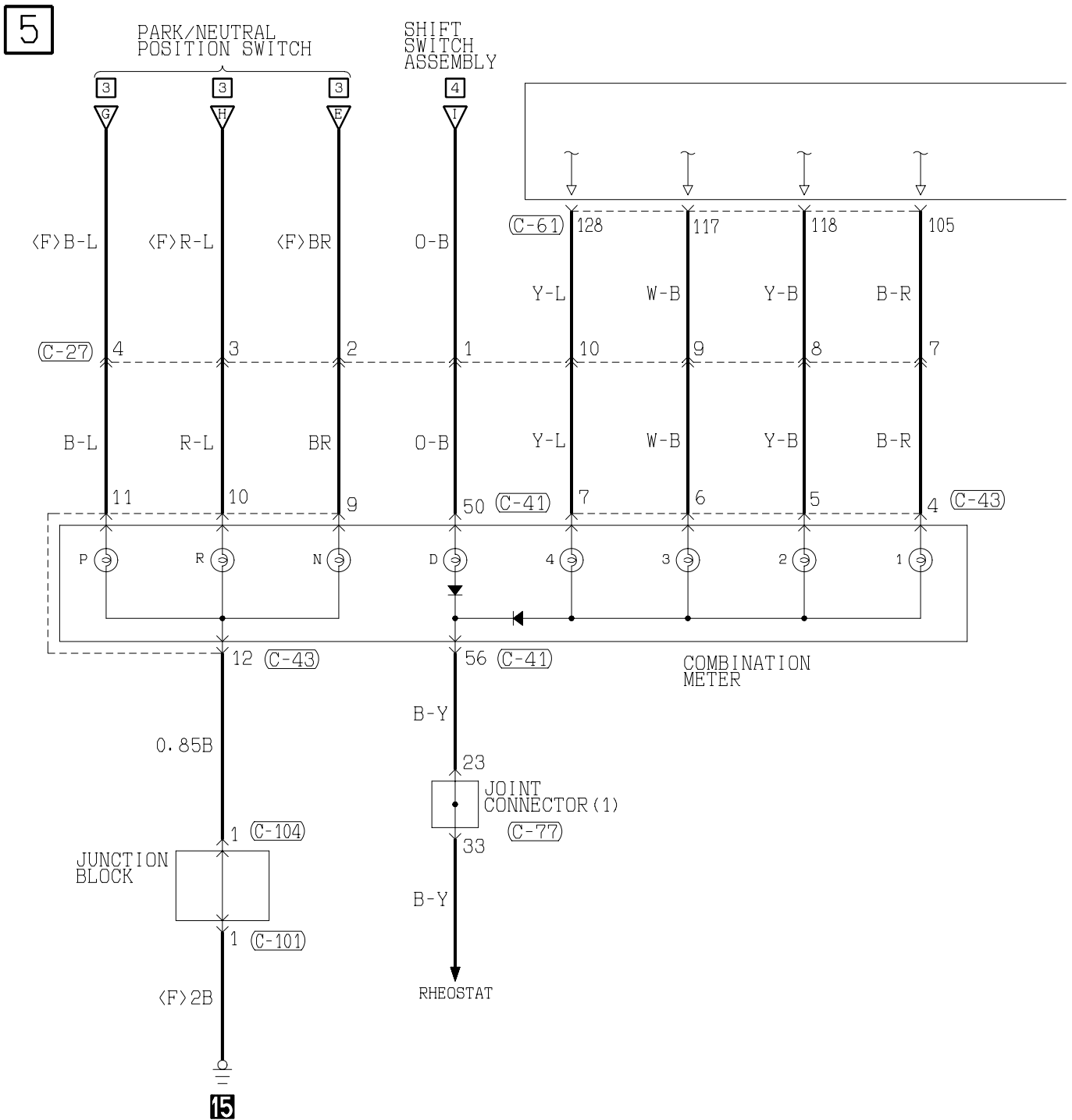

H1807M03CA

**6**

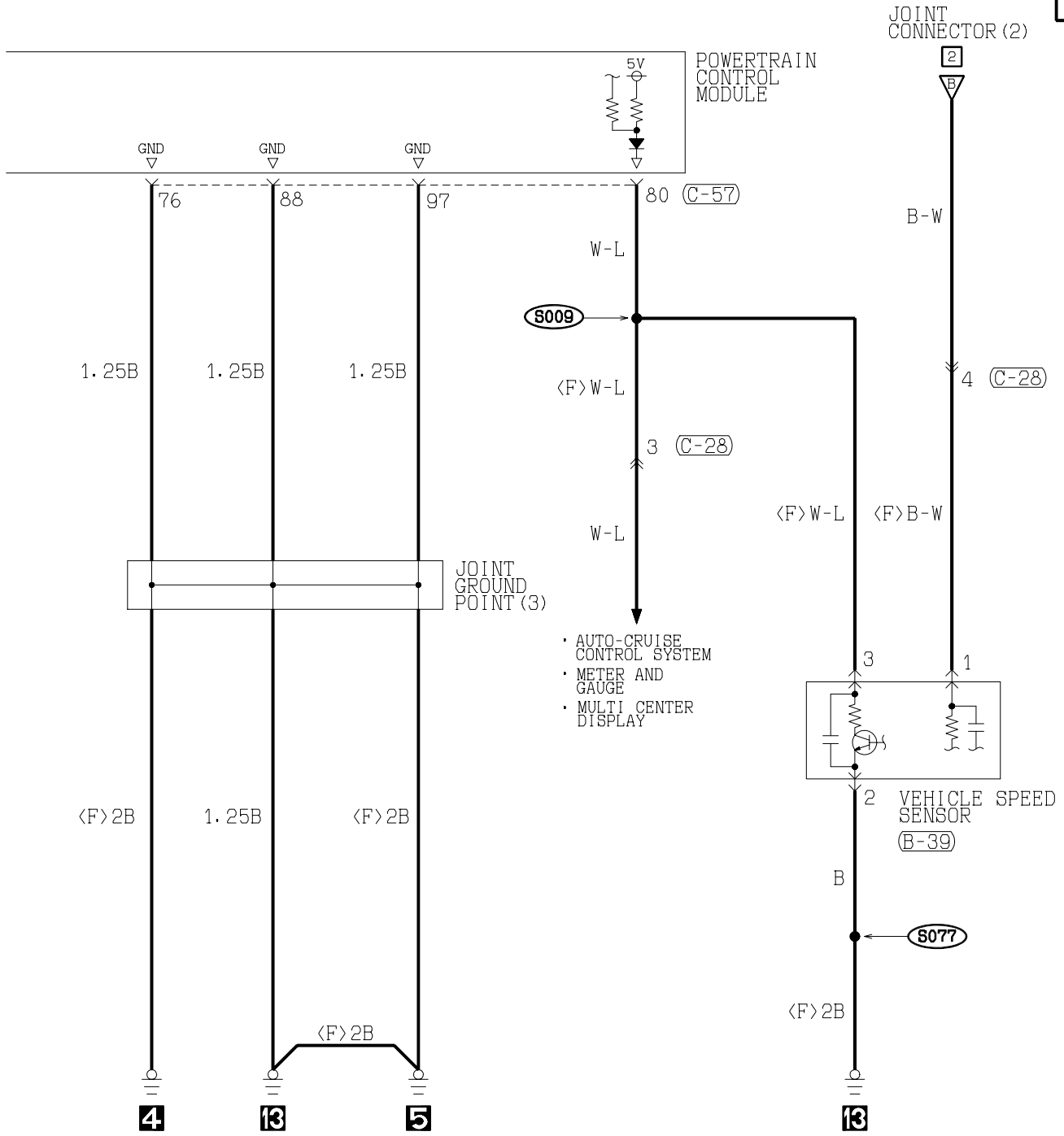

(C-57) (MU803782)

71	72	73	74		75	76	77				
78	79	80	81	82	83	84	85	86	87	88	89
90	91	92	93	94	95	96	97	98			

(C-61) (MU803783)

101	102	103	104		105	106	107					
108	109	110	111	112	113	114	115	116	117	118	119	120
121	122	123	124	125	126	127	128	129	130			

(C-77)

1	2	3	4	5	6	7	8	9	10	11
12	13	14	15	16	17	18	19	20	21	22
23	24	25	26	27	28	29	30	31	32	33

(C-101) MU801331

1		2	
3	4	5	6

(C-104) MU801457

1	2	3	4	5	6	7	8	9		
10	11	12	13	14	15	16	17	18	19	20

**WIRE COLOR CODE**

B : BLACK    BR : BROWN    G : GREEN    GR : GRAY    L : BLUE    LG : LIGHT GREEN    O : ORANGE  
 P : PINK    R : RED    SB : SKY BLUE    V : VIOLET    W : WHITE    Y : YELLOW

H1S07M03CB

**TSB Revision**



8

NOTE  
 \*1: UNDERDRIVE SOLENOID VALVE  
 \*2: SECOND SOLENOID VALVE  
 \*3: OVERDRIVE SOLENOID VALVE  
 \*4: TORQUE CONVERTER CLUTCH CONTROL SOLENOID VALVE  
 \*5: LOW AND REVERSE SOLENOID VALVE

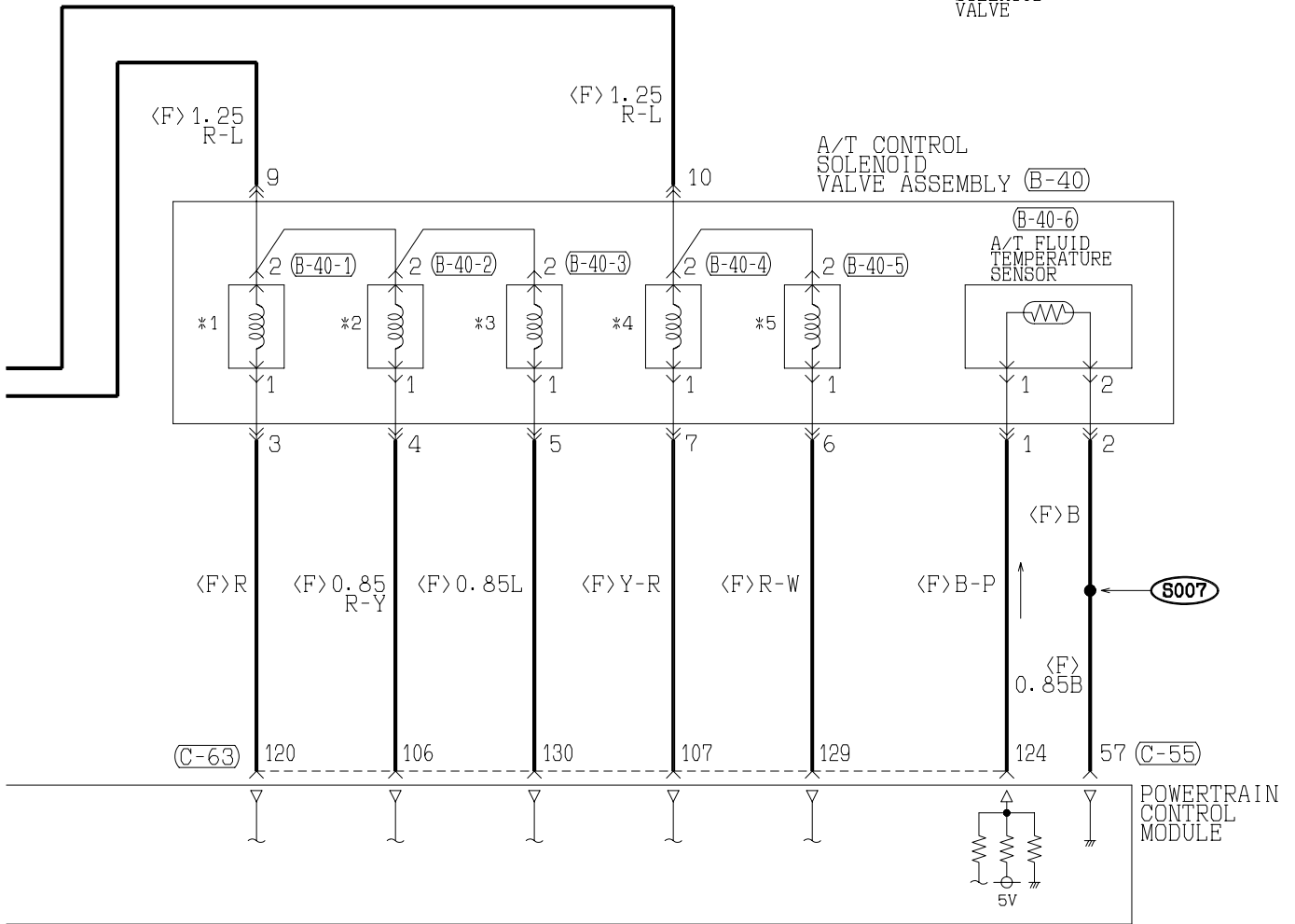

(C-54) (MU803781)

41	42	43		44	45	46				
47	48	49	50	51	52	53	54	55	56	57
58	59	60	61	62	63	64	65	66		

(C-57) (MU803782)

71	72	73	74		75	76	77				
78	79	80	81	82	83	84	85	86	87	88	89
90	91	92	93	94	95	96	97	98			

(C-61) (MU803783)

101	102	103	104		105	106	107					
108	109	110	111	112	113	114	115	116	117	118	119	120
121	122	123	124	125	126	127	128	129	130			

WIRE COLOR CODE  
 B : BLACK BR : BROWN G : GREEN GR : GRAY L : BLUE LG : LIGHT GREEN O : ORANGE  
 P : PINK R : RED SB : SKY BLUE V : VIOLET W : WHITE Y : YELLOW

H1S07M03DB

**TSB Revision**

INVECS-II 4A/T <VEHICLES WITH SPORT MODE TYPE (2.4L ENGINE) > (CONTINUED)

9

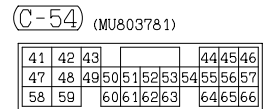
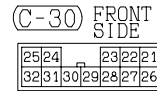
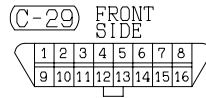
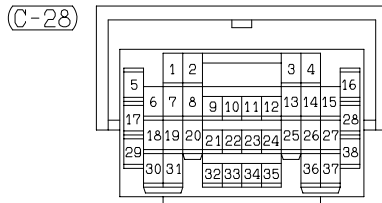
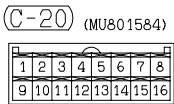
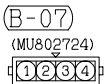
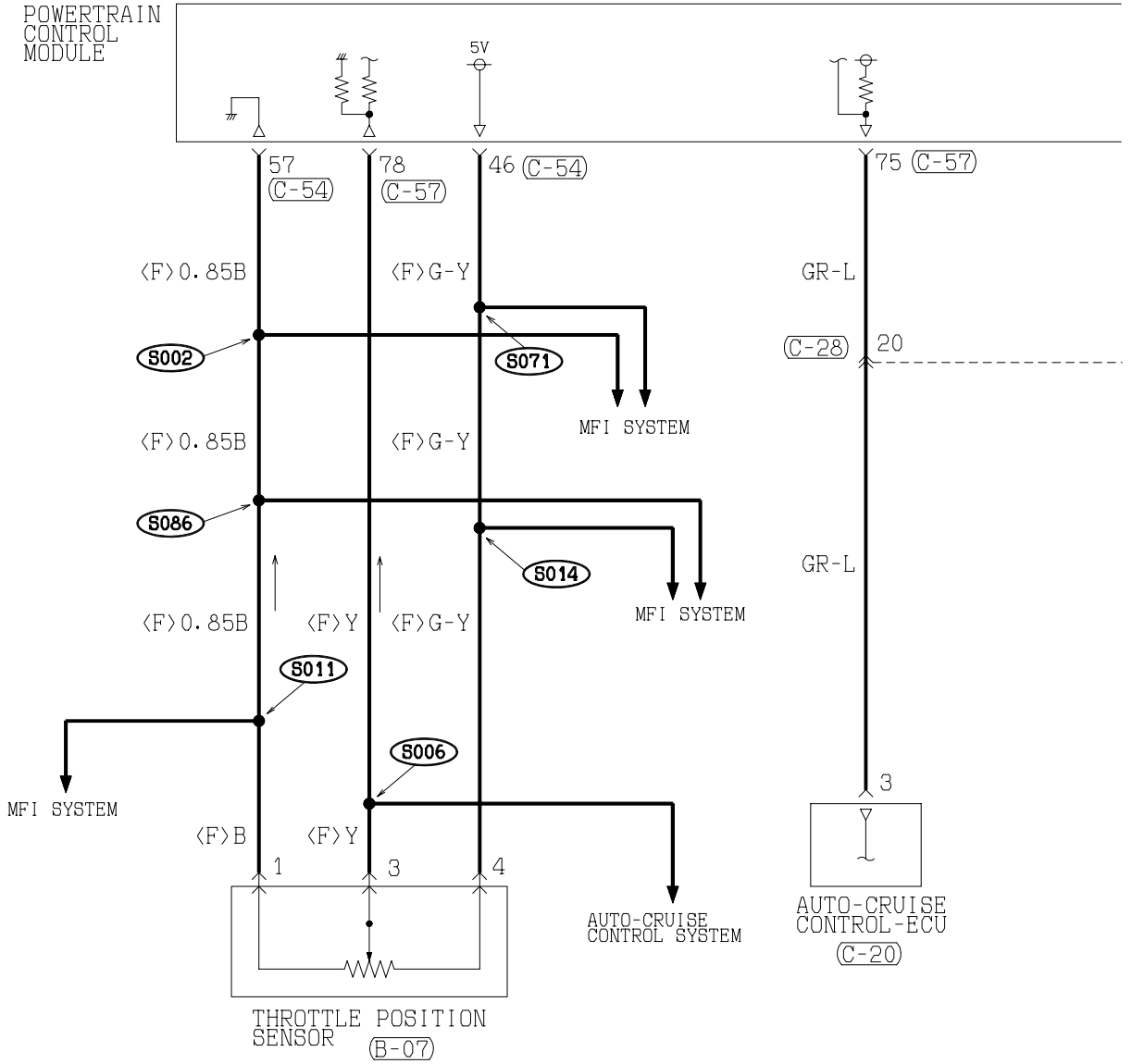

H1S07M03EA

TSB Revision



10

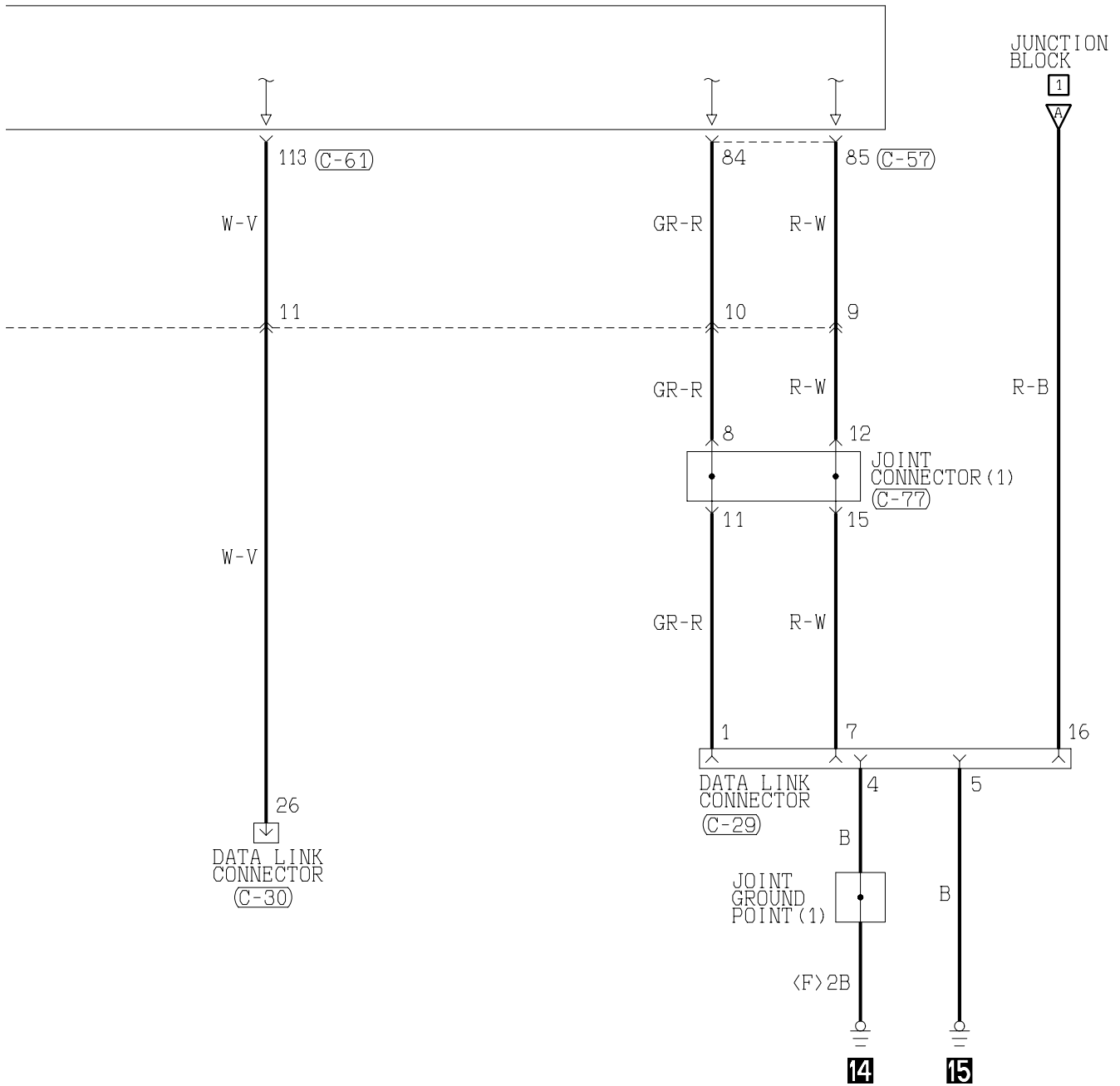

(C-57) (MU803782)

71	72	73	74			75	76	77
78	79	80	81	82	83	84	85	86
87	88	89						
90	91	92	93	94	95	96	97	98

(C-61) (MU803783)

101	102	103	104			105	106	107
108	109	110	111	112	113	114	115	116
117	118	119	120					
121	122	123	124	125	126	127	128	129
130								

(C-77)

1	2	3	4	5	6	7	8	9	10	11
12	13	14	15	16	17	18	19	20	21	22
23	24	25	26	27	28	29	30	31	32	33

WIRE COLOR CODE  
 B : BLACK    BR : BROWN    G : GREEN    GR : GRAY    L : BLUE    LG : LIGHT GREEN    O : ORANGE  
 P : PINK    R : RED    SB : SKY BLUE    V : VIOLET    W : WHITE    Y : YELLOW

H1S07M03EB

**TSB Revision**

# INVECS-II 4A/T <VEHICLES WITH SPORT MODE TYPE (3.0L ENGINE) >

M1901016200090

1

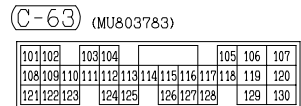
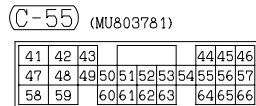
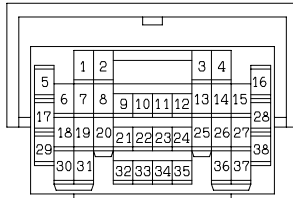
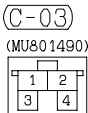
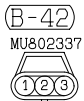
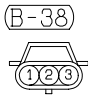
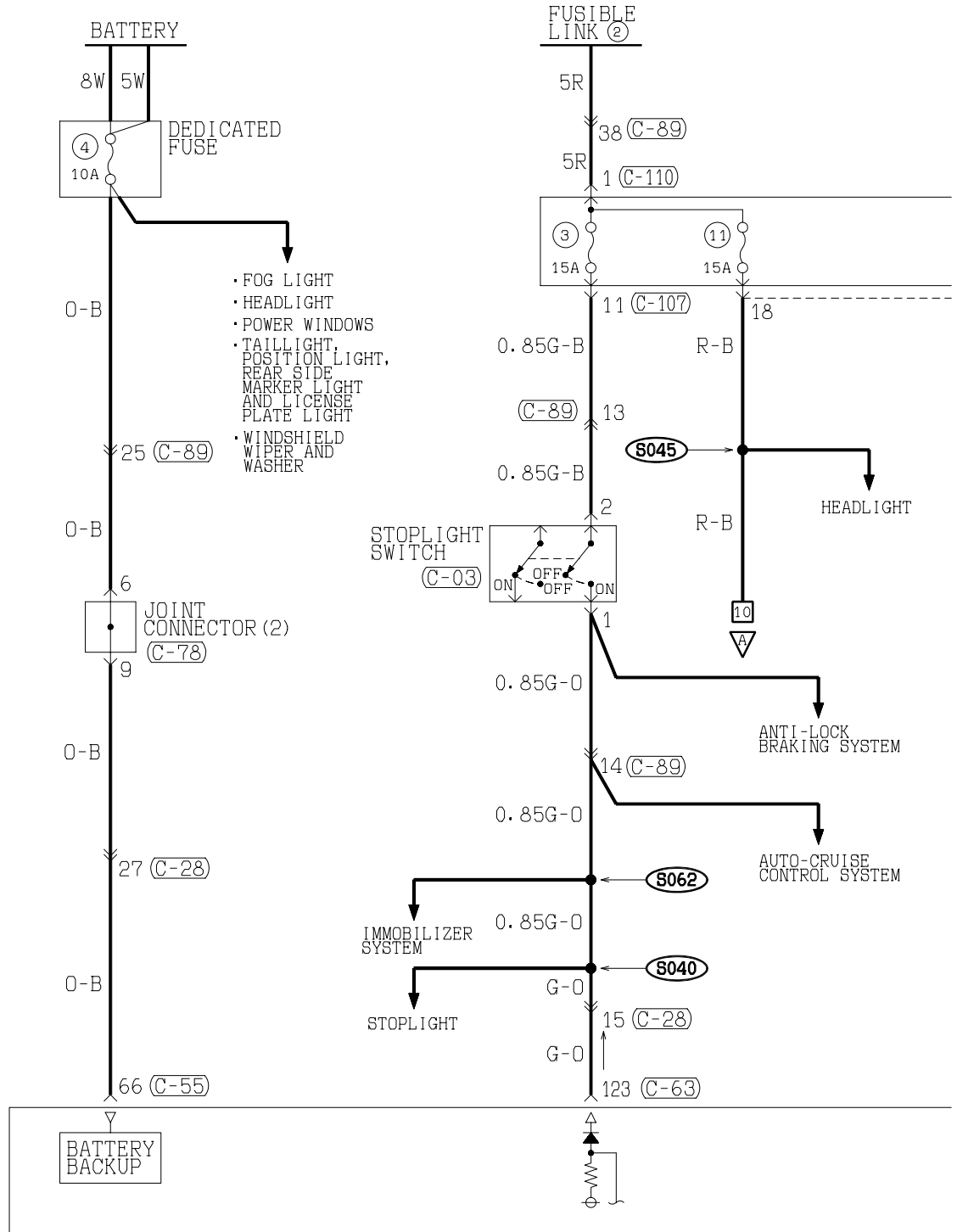

H1S07M05AA

TSB Revision

2

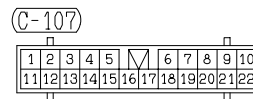
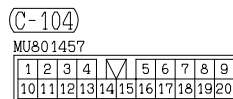
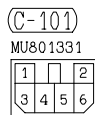
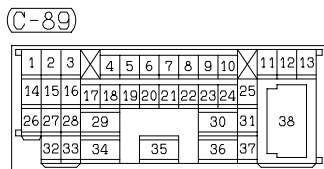
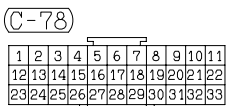
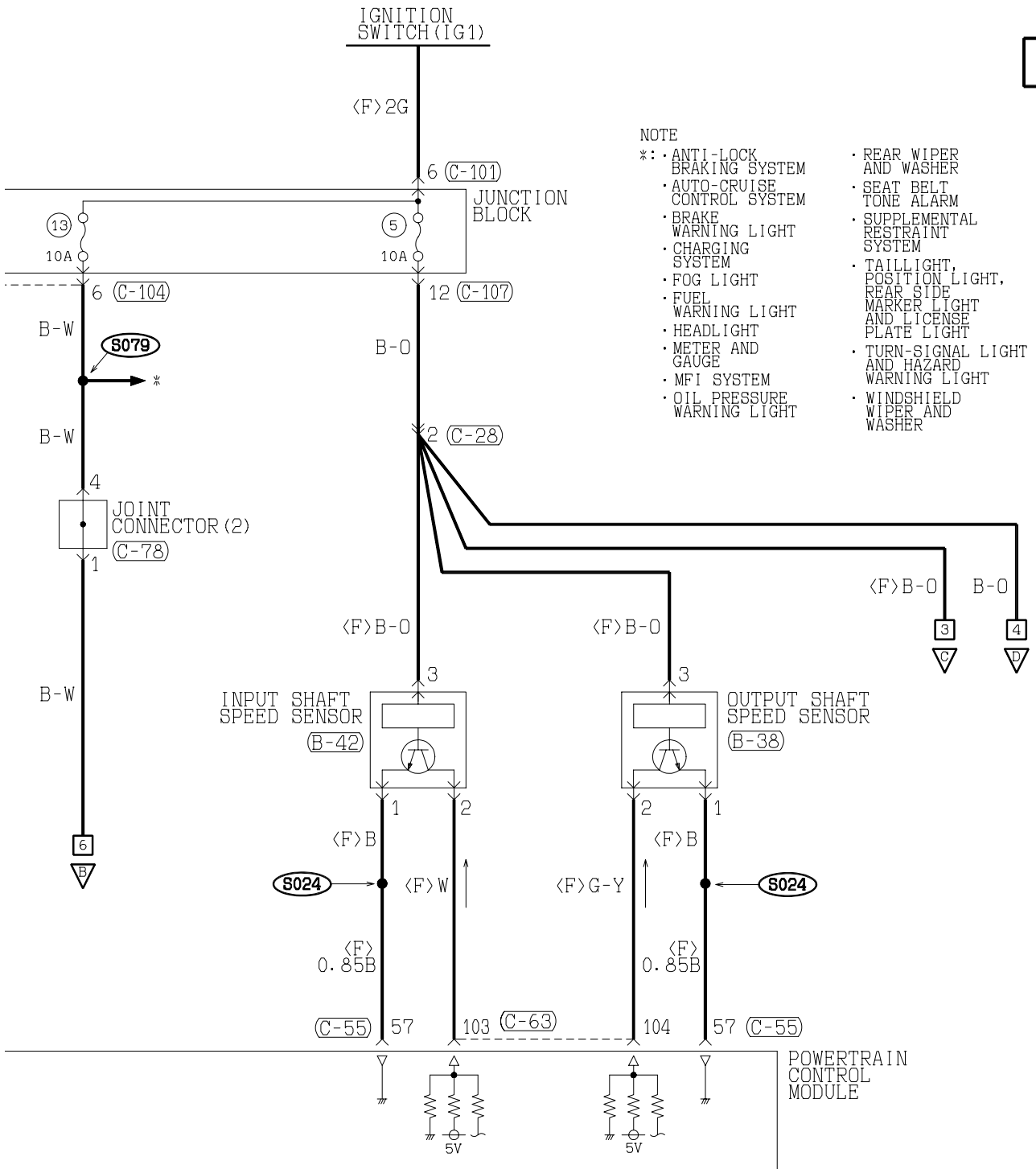

INVECS-II 4A/T <VEHICLES WITH SPORT MODE TYPE (3.0L ENGINE) > (CONTINUED)

3

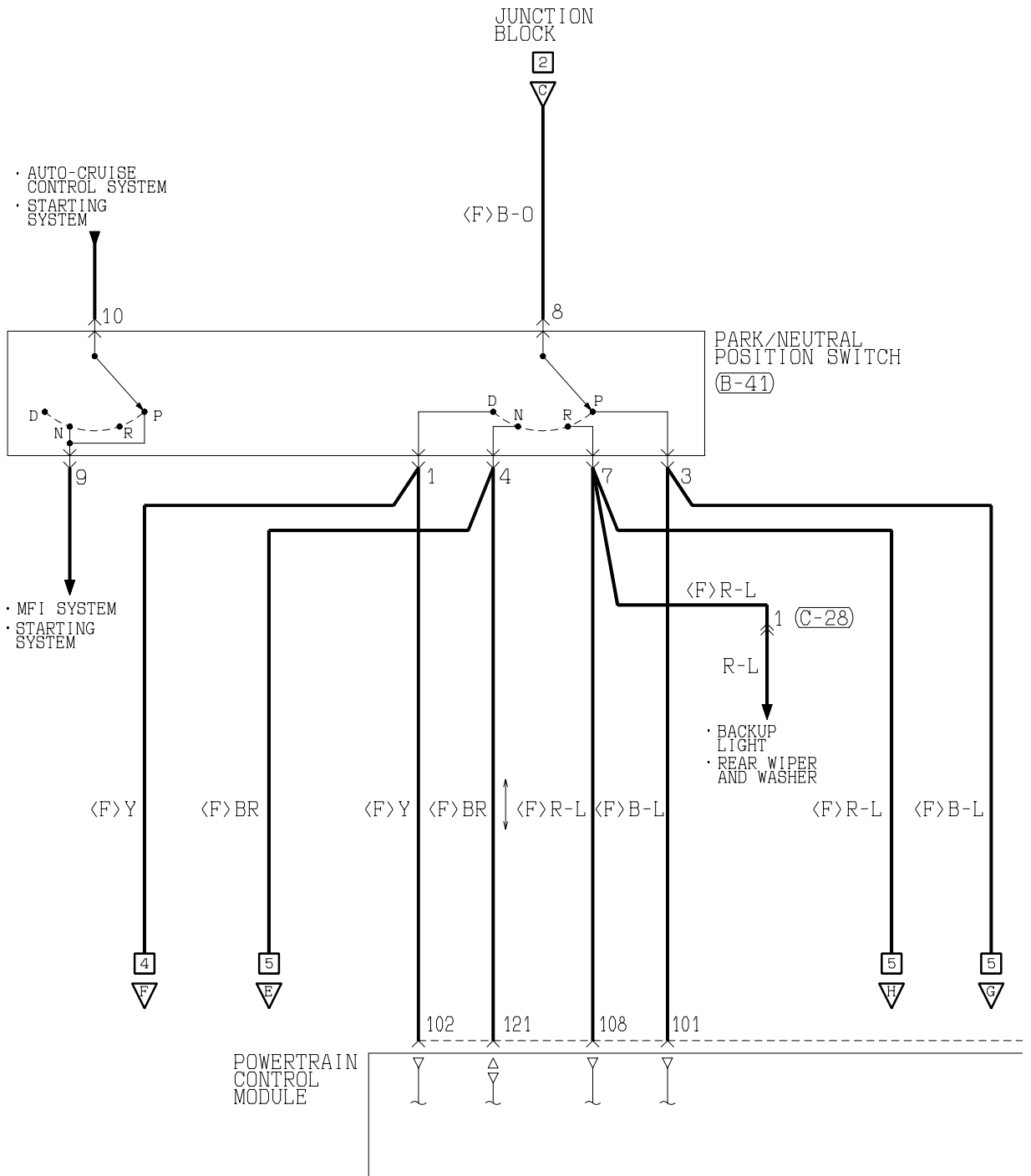

(B-41) MU802355

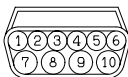

(C-28)

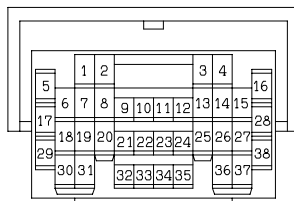

(C-63) (MU803783)

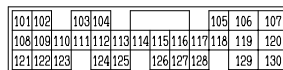

(C-65)



TSB Revision

4

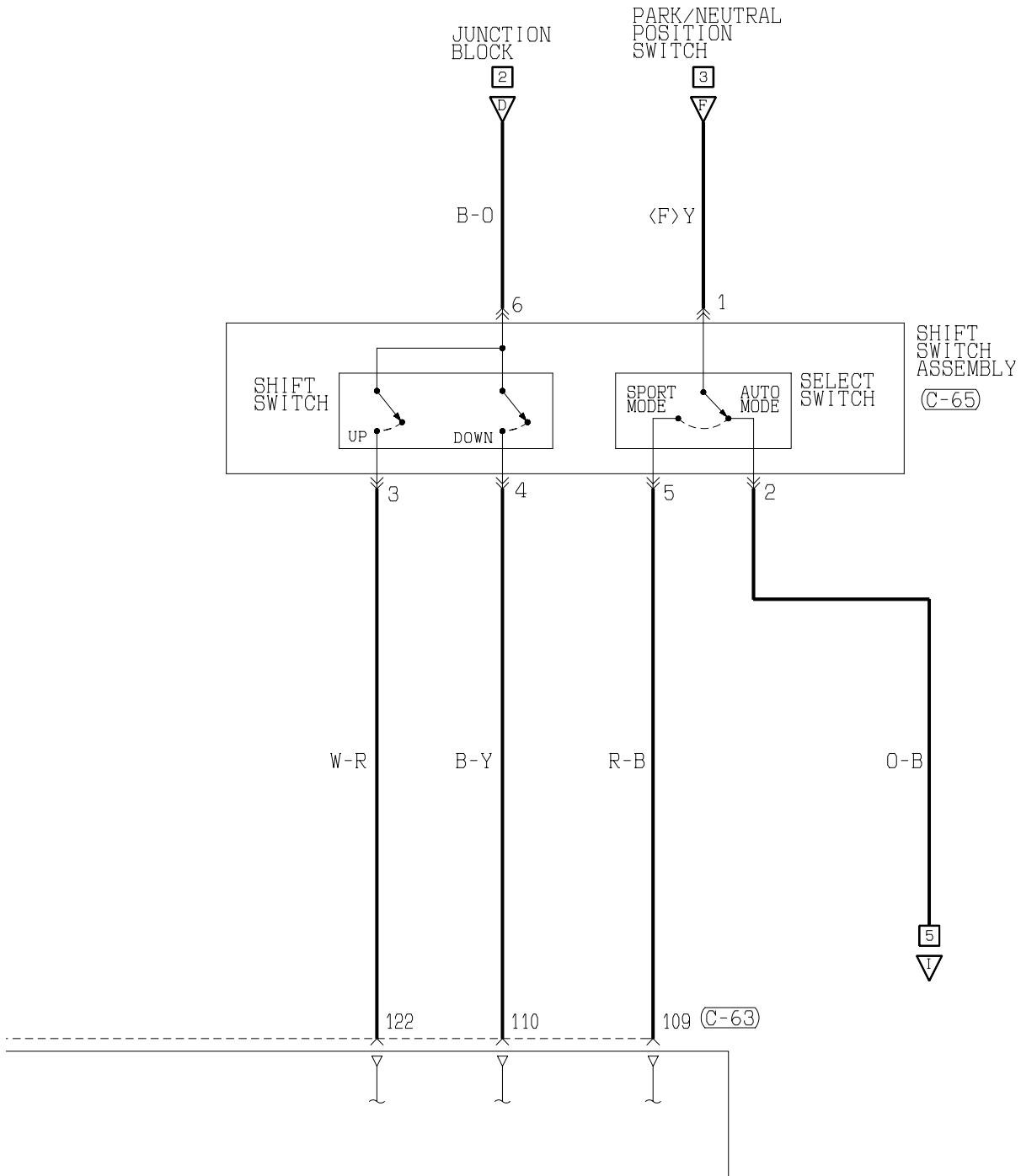

**TSB Revision**

INVECS-II 4A/T <VEHICLES WITH SPORT MODE TYPE (3.0L ENGINE) > (CONTINUED)

5

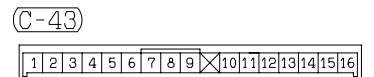
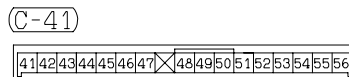
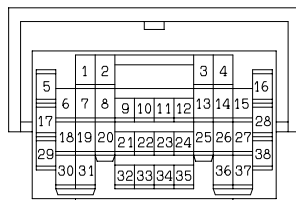
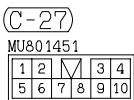
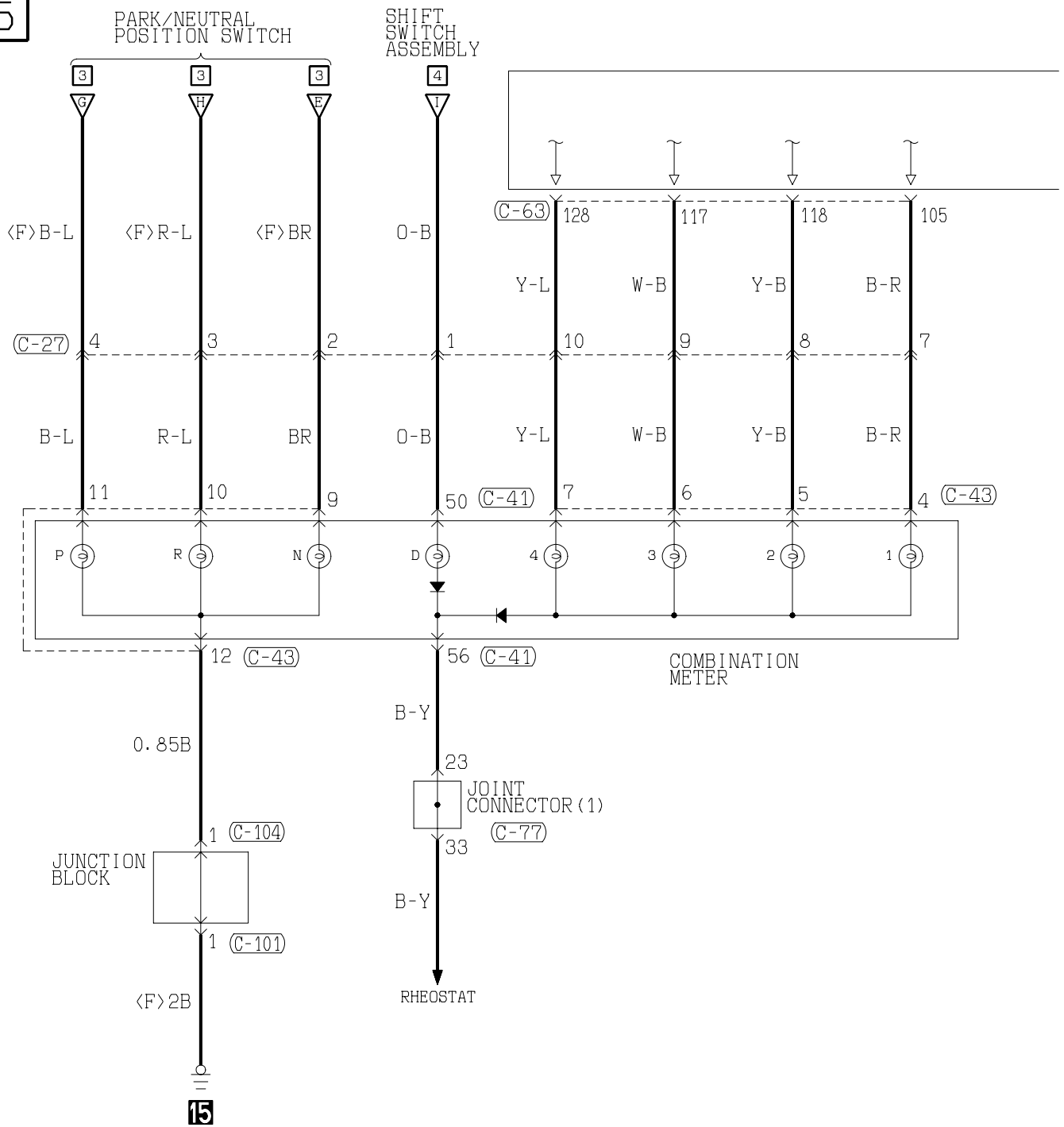

H1S07M05CA

TSB Revision

6

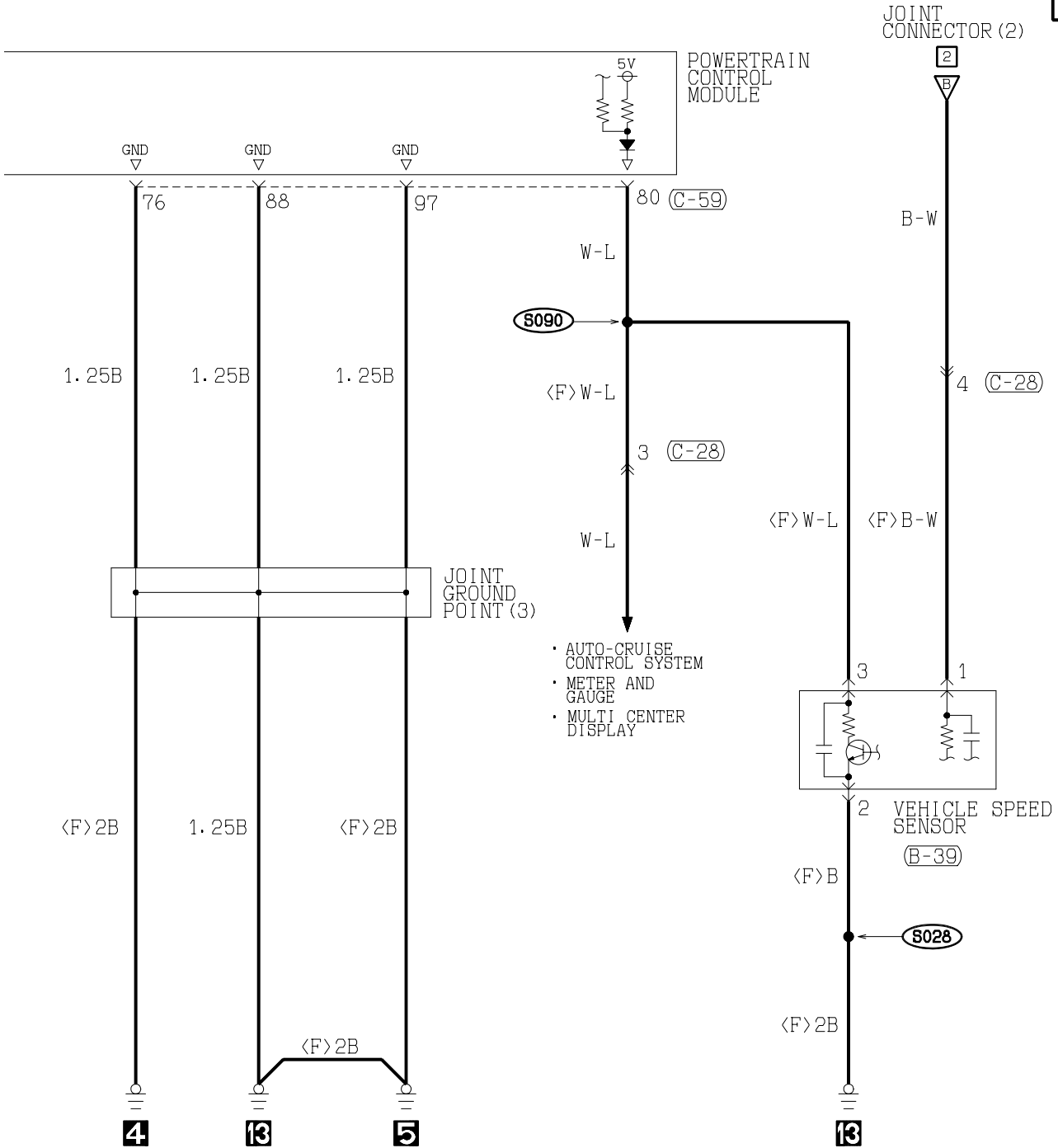

(C-59) (MU803782)

71	72	73	74	75	76	77					
78	79	80	81	82	83	84	85	86	87	88	89
90	91	92	93	94	95	96	97	98			

(C-63) (MU803783)

101	102	103	104	105	106	107						
108	109	110	111	112	113	114	115	116	117	118	119	120
121	122	123	124	125	126	127	128	129	130			

(C-77)

1	2	3	4	5	6	7	8	9	10	11
12	13	14	15	16	17	18	19	20	21	22
23	24	25	26	27	28	29	30	31	32	33

(C-101)

MU801331

1	2		
3	4	5	6

(C-104)

MU801457

1	2	3	4	5	6	7	8	9		
10	11	12	13	14	15	16	17	18	19	20

**WIRE COLOR CODE**

B : BLACK    BR : BROWN    G : GREEN    GR : GRAY    L : BLUE    LG : LIGHT GREEN    O : ORANGE  
 P : PINK    R : RED    SB : SKY BLUE    V : VIOLET    W : WHITE    Y : YELLOW

H1S07M05CB

**TSB Revision**

INVECS-II 4A/T <VEHICLES WITH SPORT MODE TYPE (3.0L ENGINE) > (CONTINUED)

7

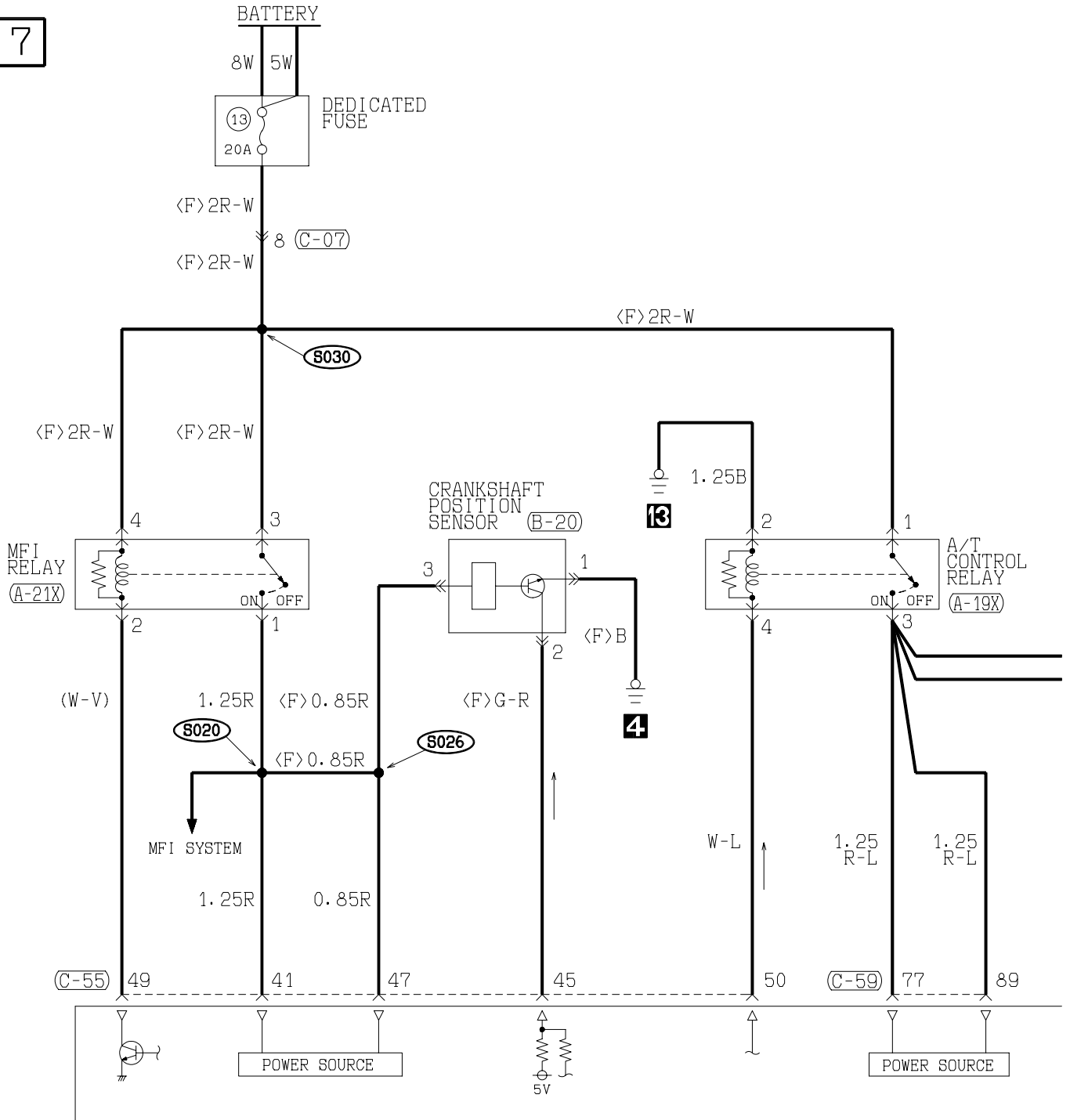

- (A-19X)
- (A-21X)
- (B-20) MU802603
- (B-40) (MU802362)
- (B-40-1) (MU801212)
- (B-40-2) (MU801212)
- (B-40-3) (MU801212)
- (B-40-4) (MU801212)
- (B-40-5) (MU801212)
- (B-40-6) MU802333
- (C-07) MU801333

TSB Revision



- NOTE
- \*1: UNDERDRIVE SOLENOID VALVE
  - \*2: SECOND SOLENOID VALVE
  - \*3: OVERDRIVE SOLENOID VALVE
  - \*4: TORQUE CONVERTER CLUTCH CONTROL SOLENOID VALVE
  - \*5: LOW AND REVERSE SOLENOID VALVE

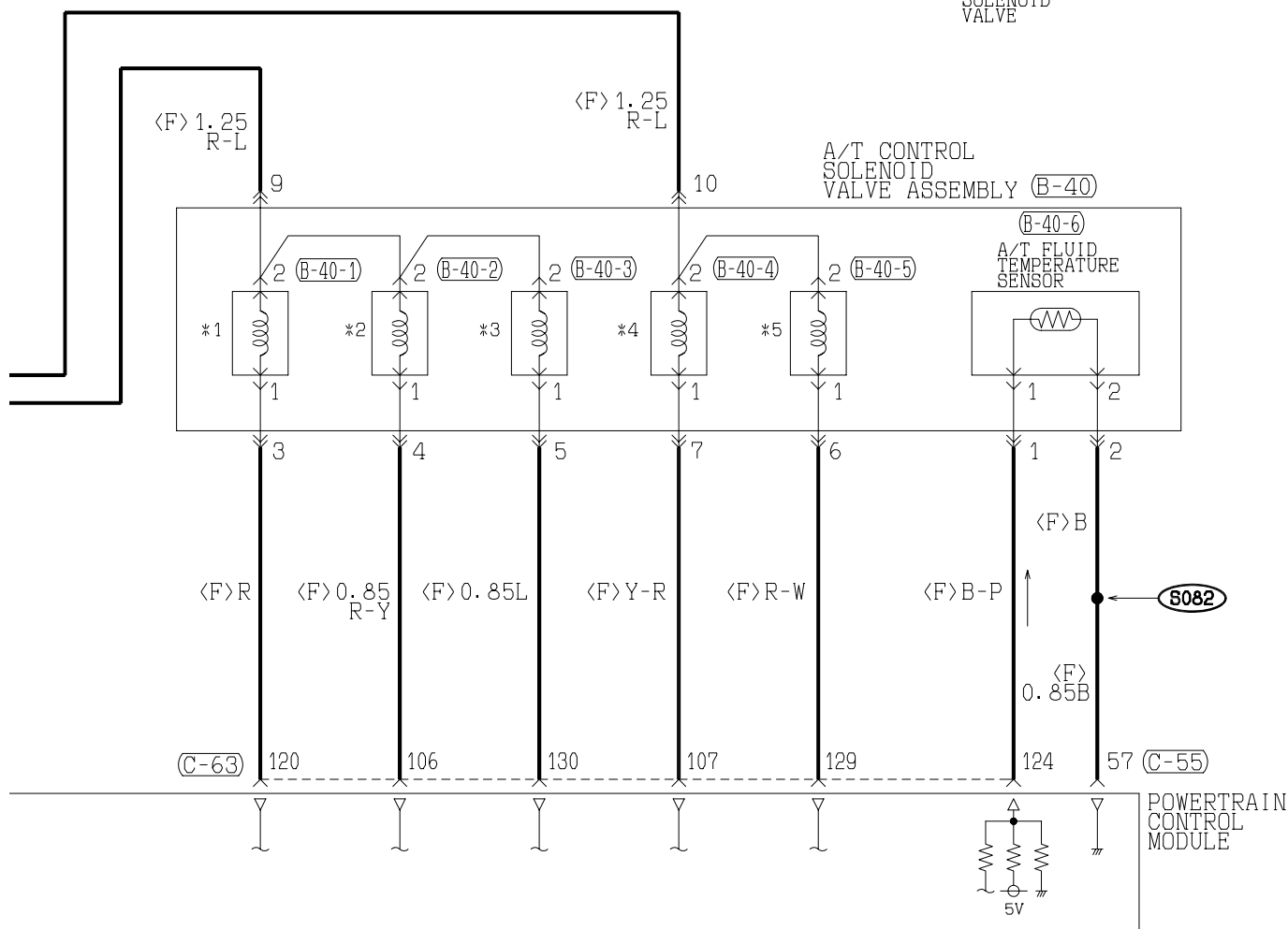

(C-55) (MU803781)

41	42	43		44	45	46				
47	48	49	50	51	52	53	54	55	56	57
58	59	60	61	62	63	64	65	66		

(C-59) (MU803782)

71	72	73	74		75	76	77				
78	79	80	81	82	83	84	85	86	87	88	89
90	91	92	93	94	95	96	97	98			

(C-63) (MU803783)

101	102	103	104		105	106	107					
108	109	110	111	112	113	114	115	116	117	118	119	120
121	122	123	124	125	126	127	128	129	130			

WIRE COLOR CODE  
 B : BLACK    BR : BROWN    G : GREEN    GR : GRAY    L : BLUE    LG : LIGHT GREEN    O : ORANGE  
 P : PINK    R : RED    SB : SKY BLUE    V : VIOLET    W : WHITE    Y : YELLOW

**TSB Revision**

INVECS-II 4A/T <VEHICLES WITH SPORT MODE TYPE (3.0L ENGINE) > (CONTINUED)

9

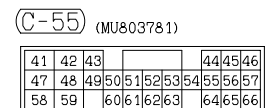
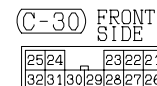
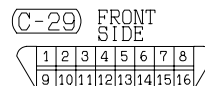
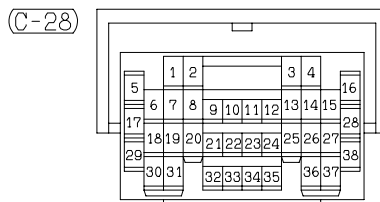
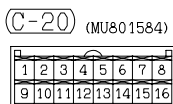
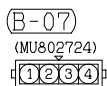
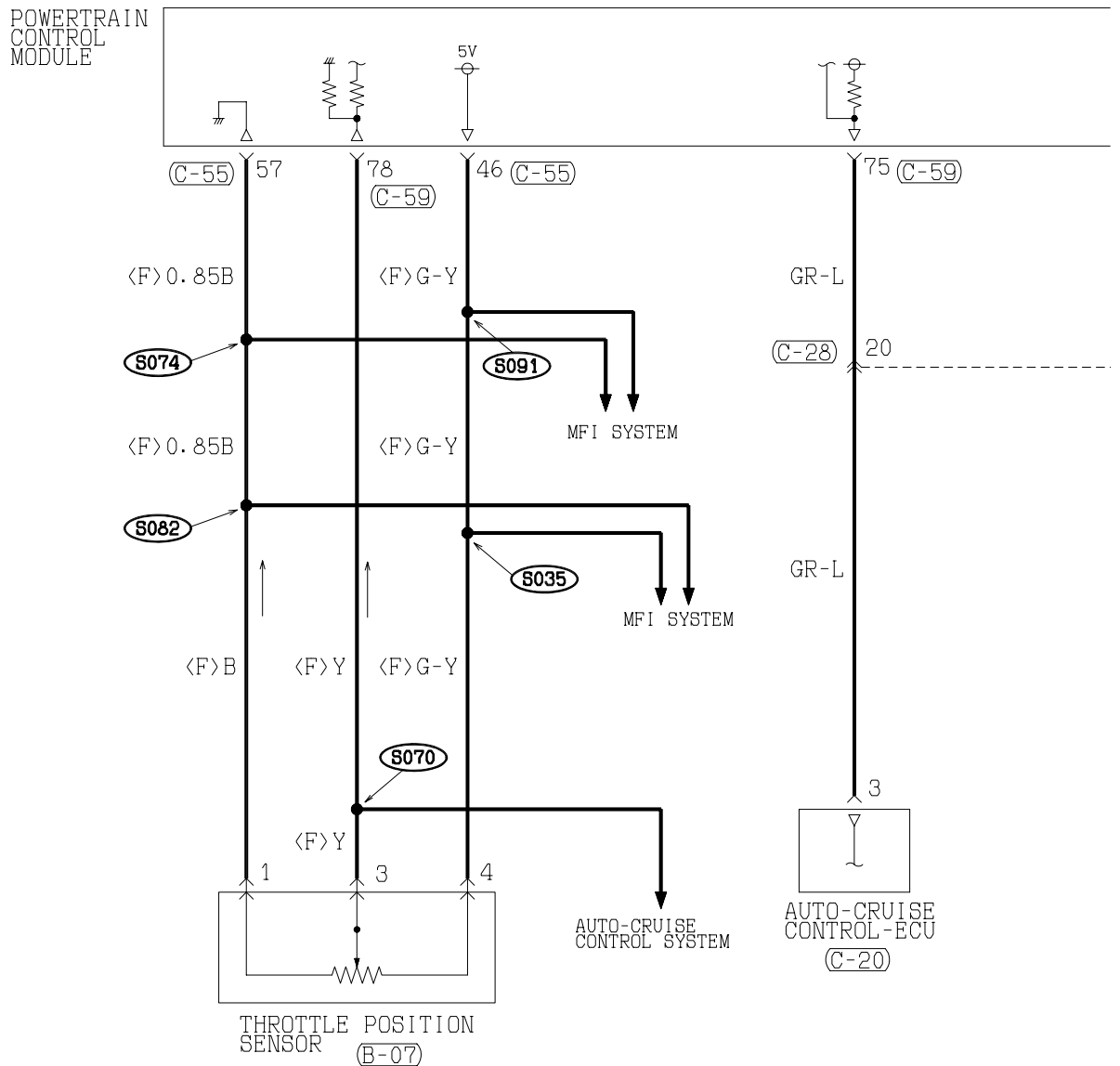

H1S07M05EA

TSB Revision

10

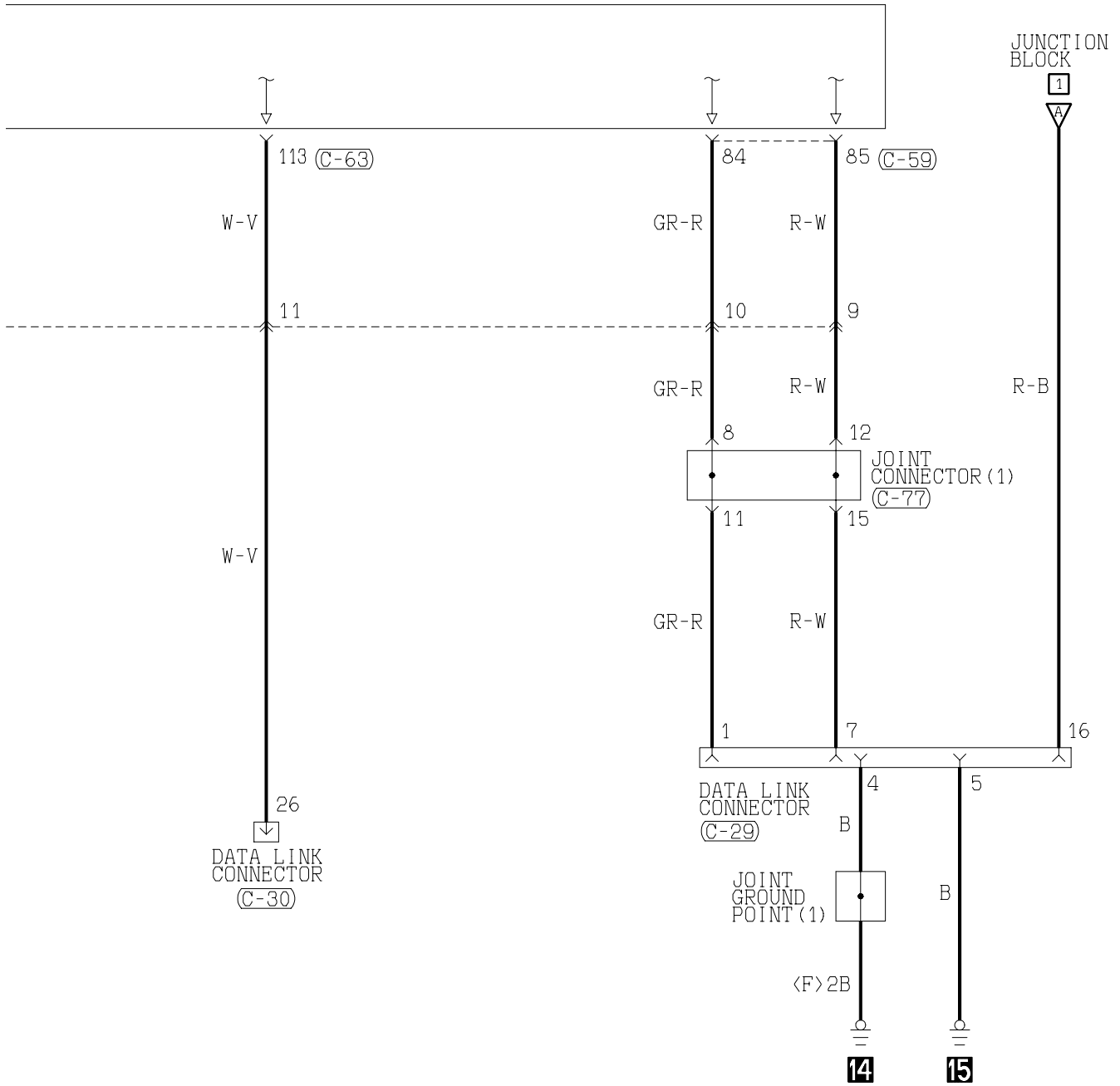

(C-59) (MU803782)

71	72	73	74	75	76	77
78	79	80	81	82	83	84
85	86	87	88	89	90	91
92	93	94	95	96	97	98

(C-63) (MU803783)

101	102	103	104	105	106	107
108	109	110	111	112	113	114
115	116	117	118	119	120	121
122	123	124	125	126	127	128
129	130					

(C-77)

1	2	3	4	5	6	7
8	9	10	11	12	13	14
15	16	17	18	19	20	21
22	23	24	25	26	27	28
29	30	31	32	33		

WIRE COLOR CODE  
 B : BLACK BR : BROWN G : GREEN GR : GRAY L : BLUE LG : LIGHT GREEN O : ORANGE  
 P : PINK R : RED SB : SKY BLUE V : VIOLET W : WHITE Y : YELLOW

H1S07M05EB

TSB Revision

# HEADLIGHT

1

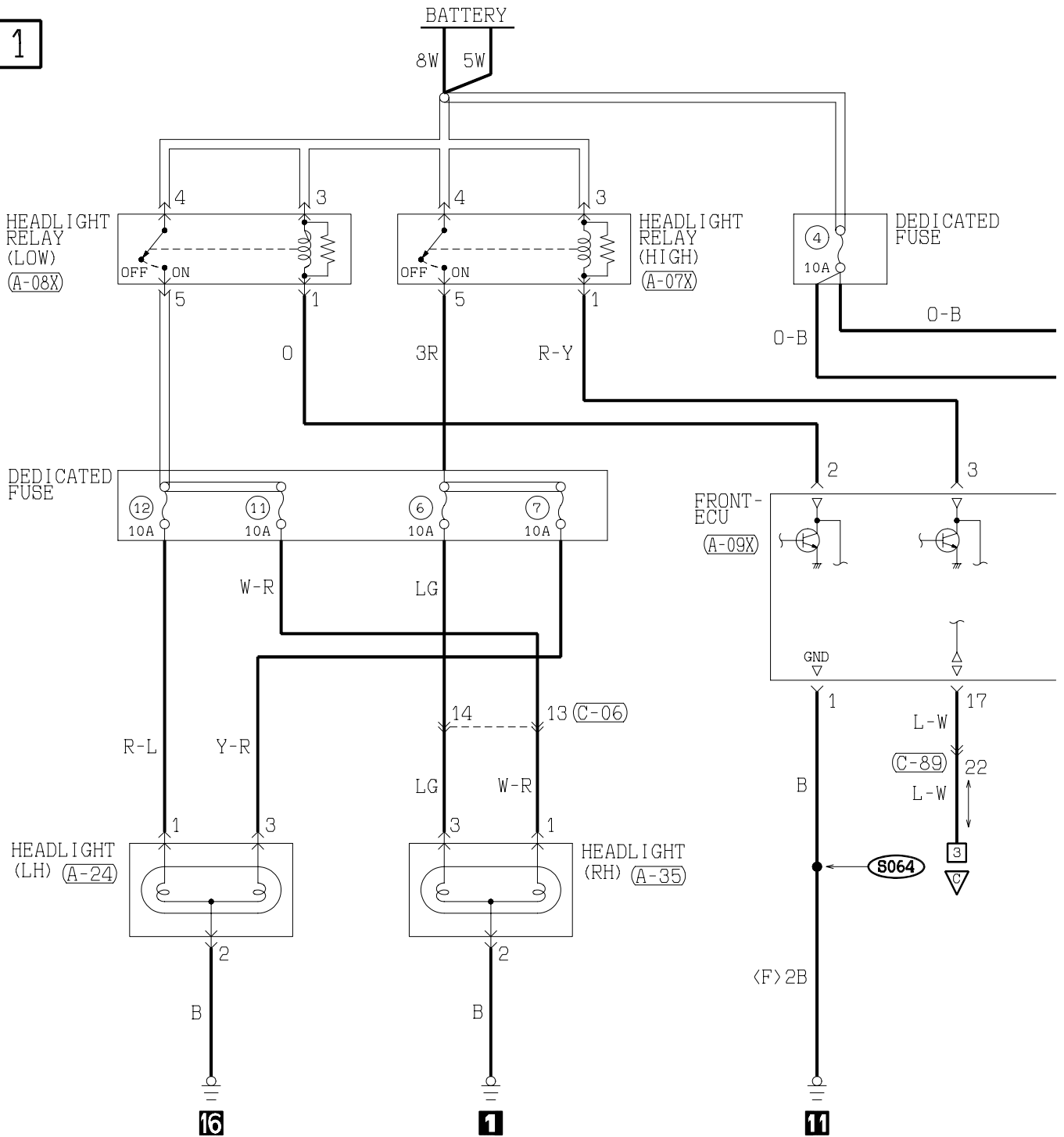

(A-07X) (A-08X) (A-09X)

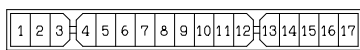
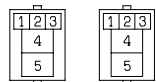

(A-24) (A-35) (C-06)

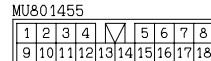
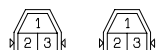

(C-78)

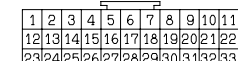

(C-109)

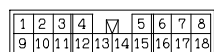

TSB Revision

2

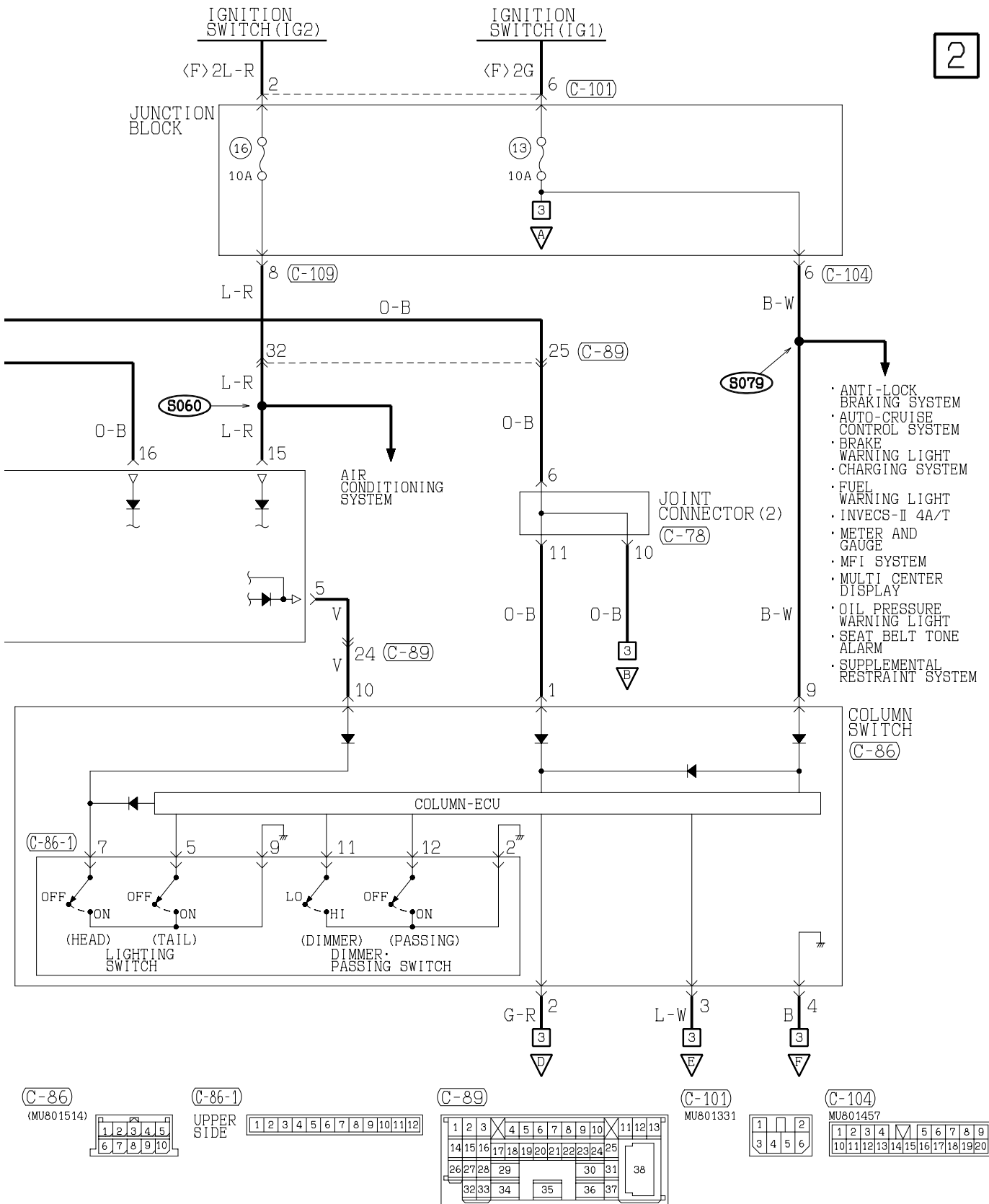

TSB Revision



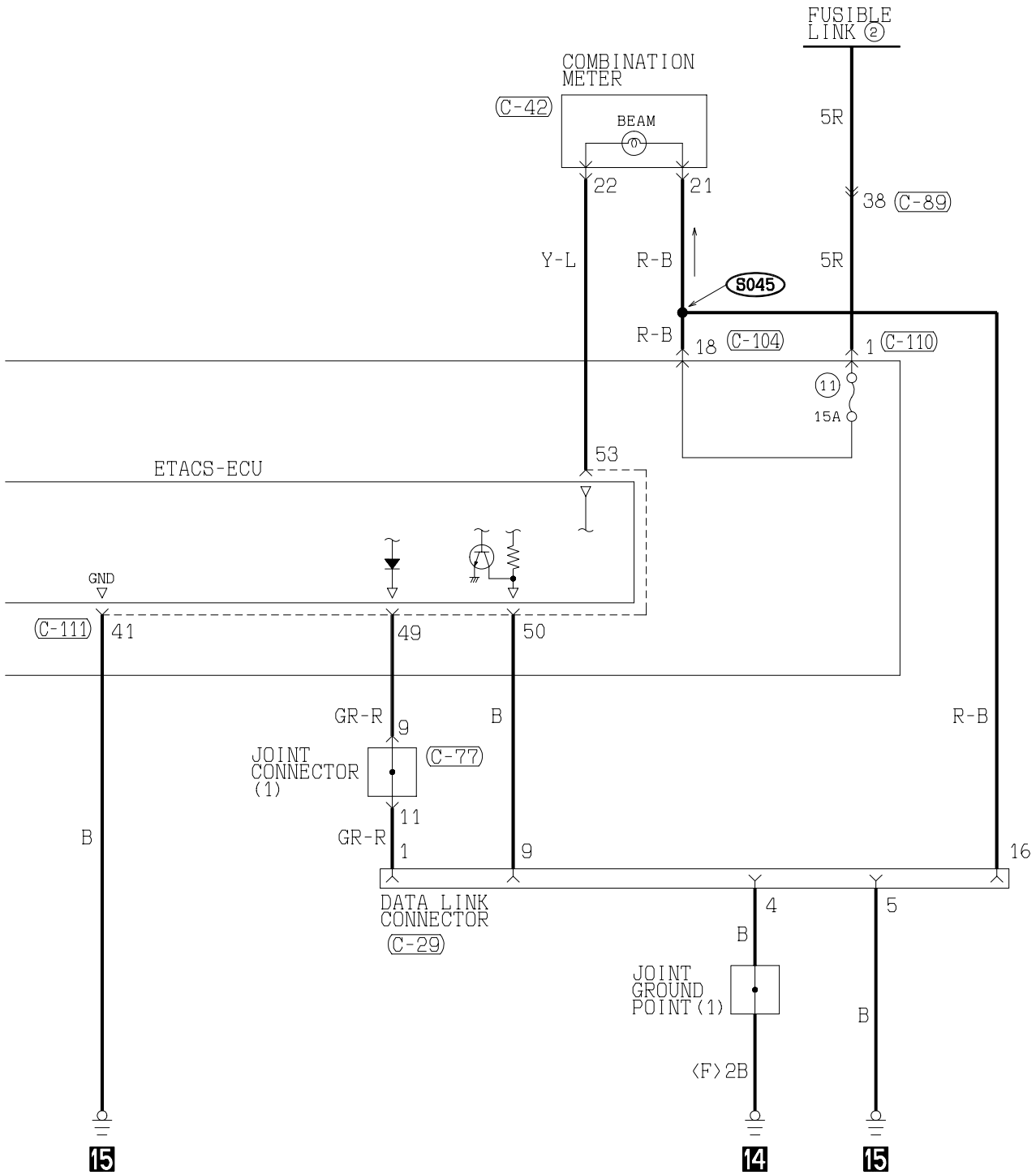

(C-101) MU801331

1	2
3	4
5	6

(C-104) MU801457

1	2	3	4	5	6	7	8	9
10	11	12	13	14	15	16	17	18
19	20							

(C-109)

1	2	3	4	5	6	7	8
9	10	11	12	13	14	15	16
17	18						

(C-110)

1
---

(C-111) (MU801584)

41	42	43	44	45	46	47	48
49	50	51	52	53	54	55	56

(C-113)

1	2	3	4	5	6	7	8	9
10	11	12	13	14	15	16	17	18
19								

WIRE COLOR CODE  
 B : BLACK BR : BROWN G : GREEN GR : GRAY L : BLUE LG : LIGHT GREEN O : ORANGE  
 P : PINK R : RED SB : SKY BLUE V : VIOLET W : WHITE Y : YELLOW

H1S08M10BB

TSB Revision

# TAILLIGHT, POSITION LIGHT, REAR SIDE MARKER LIGHT AND LICENSE PLATE LIGHT

M1901016400072

1

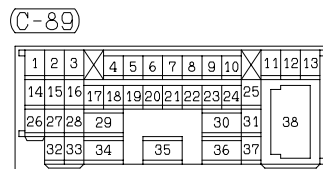
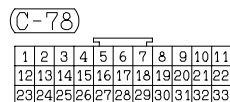
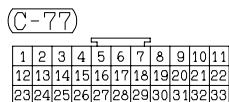
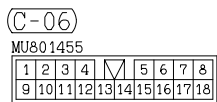
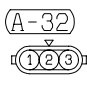
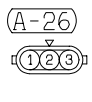
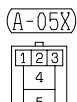
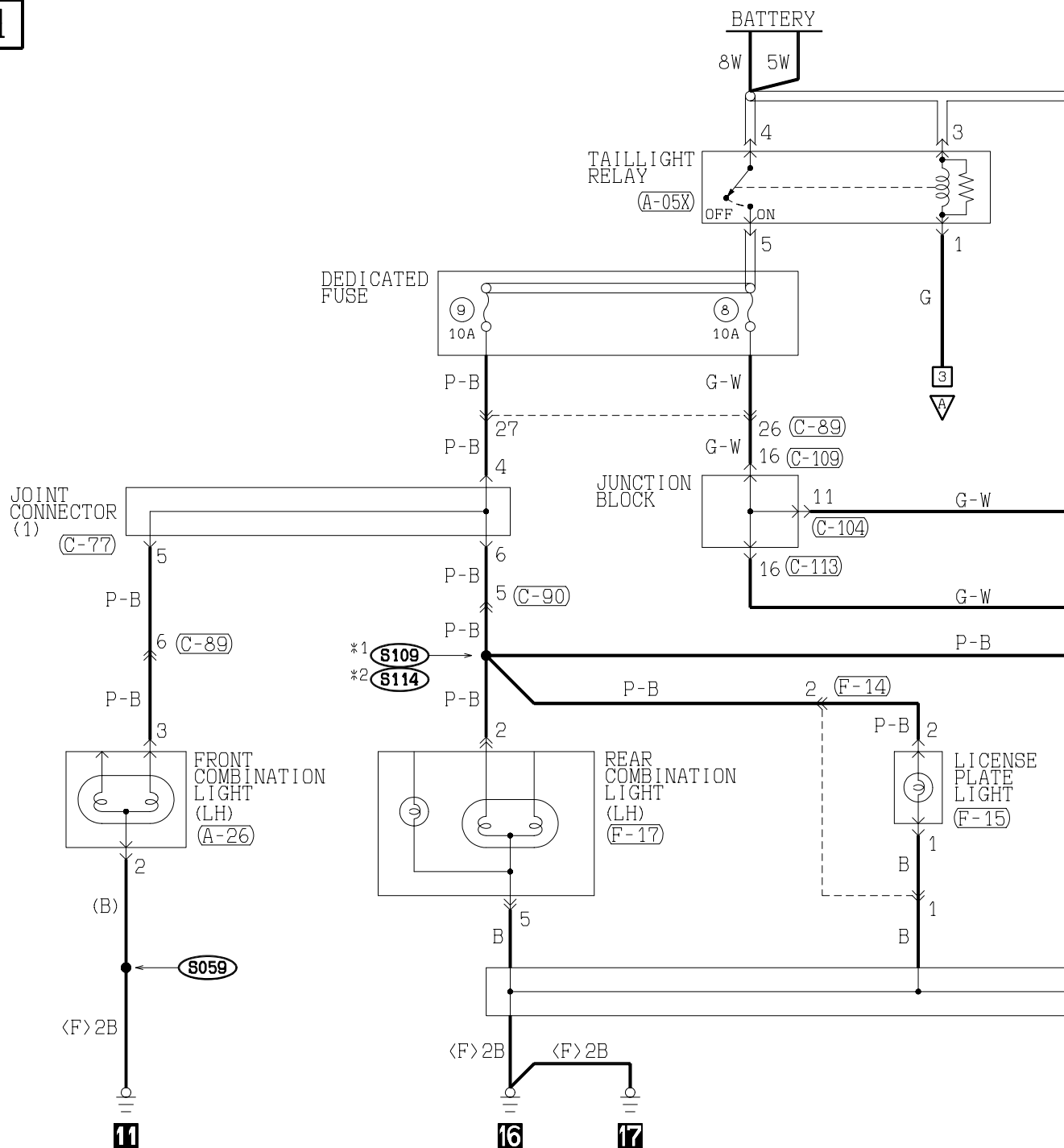

H1508M11AA

TSB Revision



2

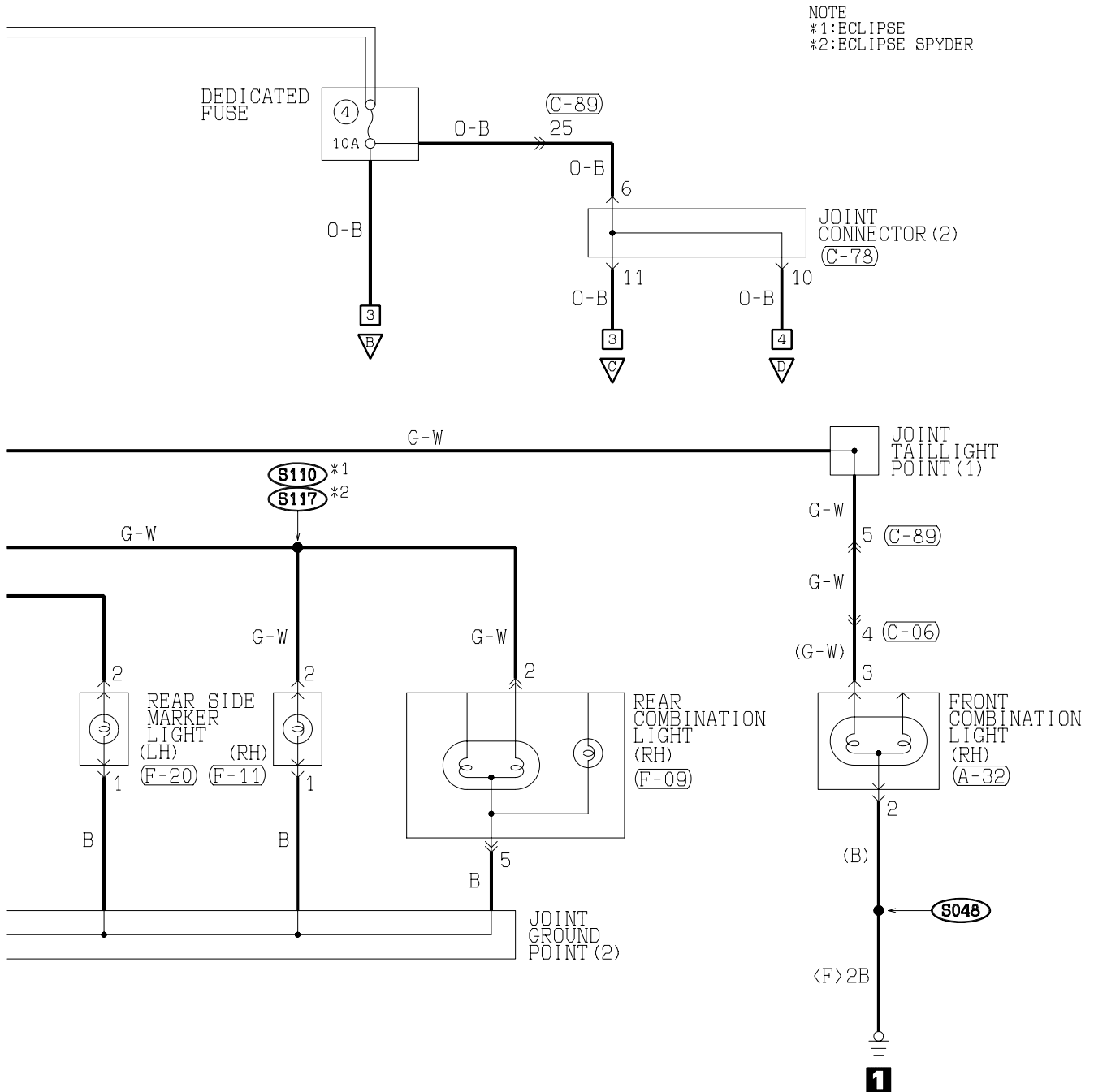

(C-90)

1	2	3	4	5	6	7	8	9
10	11	12	13	14	15	16	17	18
19	20	21	22	23	24	25	26	27
28	29	30	31	32	33	34	35	36
37	38	39	40	41	42	43		

(C-104)

MU801457

1	2	3	4	5	6	7	8	9
10	11	12	13	14	15	16	17	18
19	20	21	22	23	24	25	26	27
28	29	30	31	32	33	34	35	36
37	38	39	40	41	42	43		

(C-109)

1	2	3	4	5	6	7	8
9	10	11	12	13	14	15	16
17	18	19	20	21	22	23	24

(C-113)

1	2	3	4	5	6	7	8	9
10	11	12	13	14	15	16	17	18
19	20	21	22	23	24	25	26	27
28	29	30	31	32	33	34	35	36
37	38	39	40	41	42	43		

(F-09)

1	2	3
4	5	6

(F-11)

1	2
---	---

(F-14)

MU802335

1	2
---	---

WIRE COLOR CODE

B : BLACK BR: BROWN G : GREEN GR: GRAY  
 L : BLUE LG: LIGHT GREEN O : ORANGE P : PINK  
 R : RED SB: SKY BLUE V : VIOLET W : WHITE  
 Y : YELLOW

H1508M11AB

TSB Revision

TAILLIGHT, POSITION LIGHT, REAR SIDE MARKER LIGHT AND LICENSE PLATE LIGHT (CONTINUED)

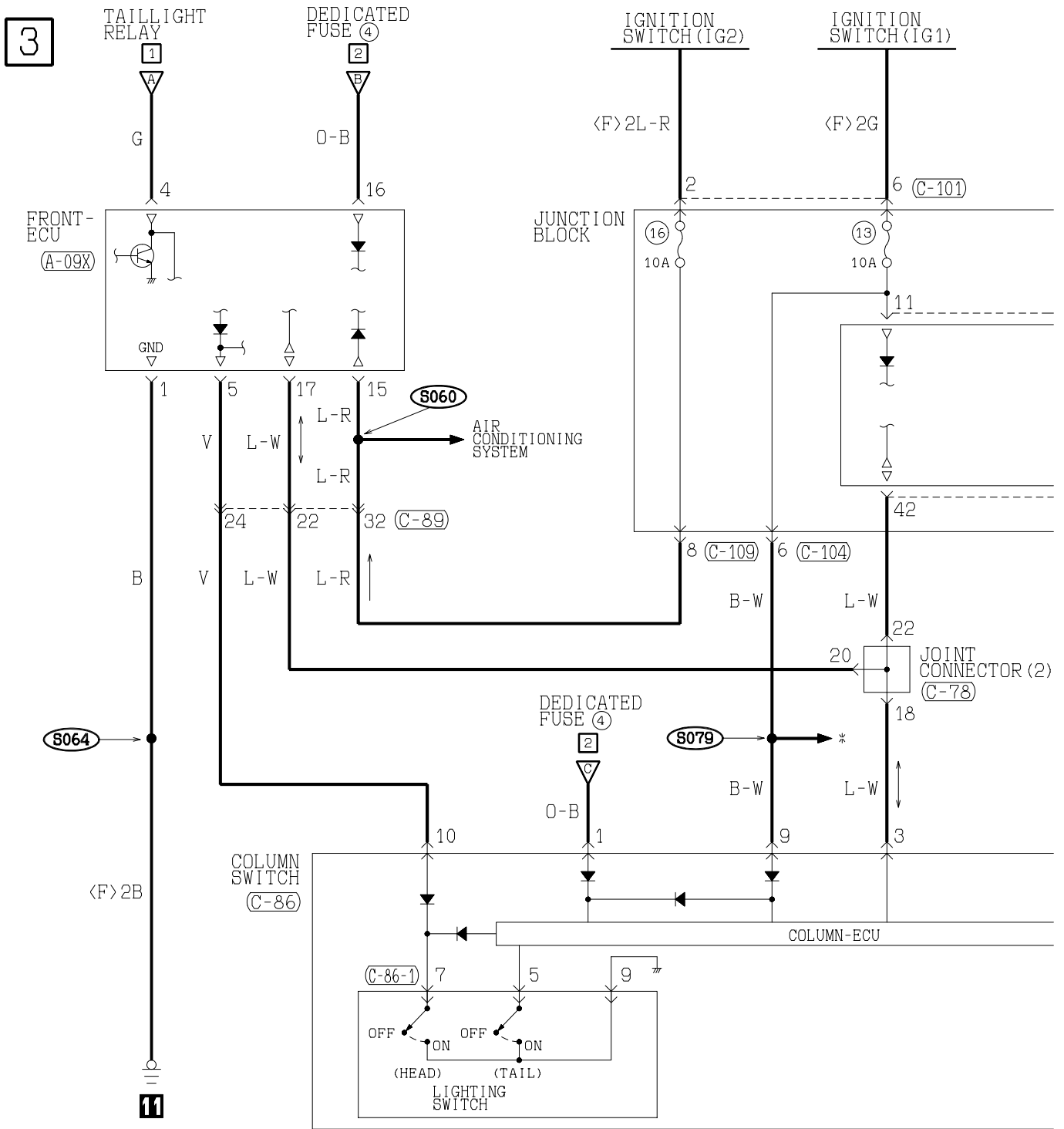

(A-09X)

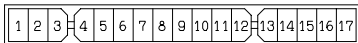

(C-29) FRONT SIDE

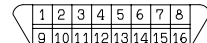

(C-77)

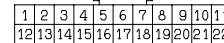

(C-78)

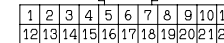

(C-86)

(MU801514)

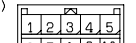

(C-110)



(C-111) (MU801584)

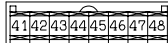

(C-114)

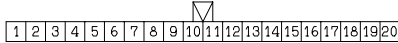

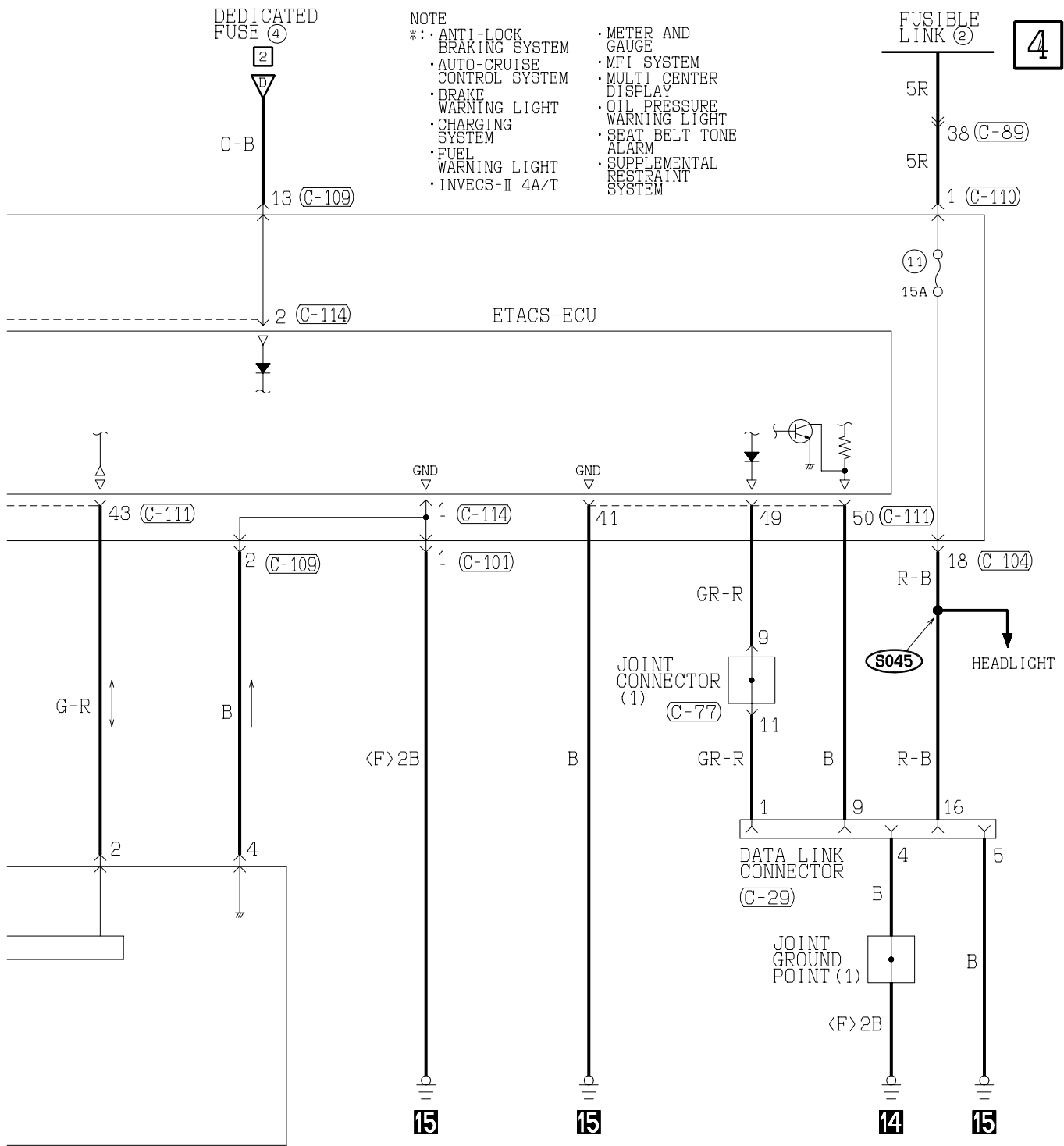

(C-86-1)

UPPER SIDE

1	2	3	4	5	6	7	8	9	10	11	12
---	---	---	---	---	---	---	---	---	----	----	----

(C-89)

1	2	3	4	5	6	7	8	9	10	11	12	13
14	15	16	17	18	19	20	21	22	23	24	25	38
26	27	28	29					30	31			
32	33	34		35		36	37					

(C-101)

MU801331

1	2
3	4
5	6

(C-104)

MU801457

1	2	3	4	5	6	7	8	9
10	11	12	13	14	15	16	17	18
19	20							

(C-109)

1	2	3	4	5	6	7	8
9	10	11	12	13	14	15	16
17	18						

H1S08M11BB



2

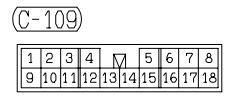
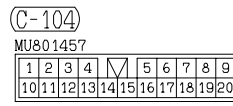
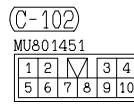
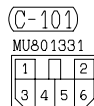
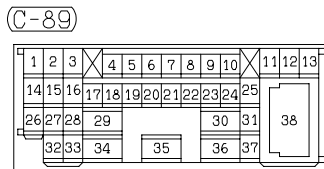
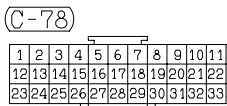
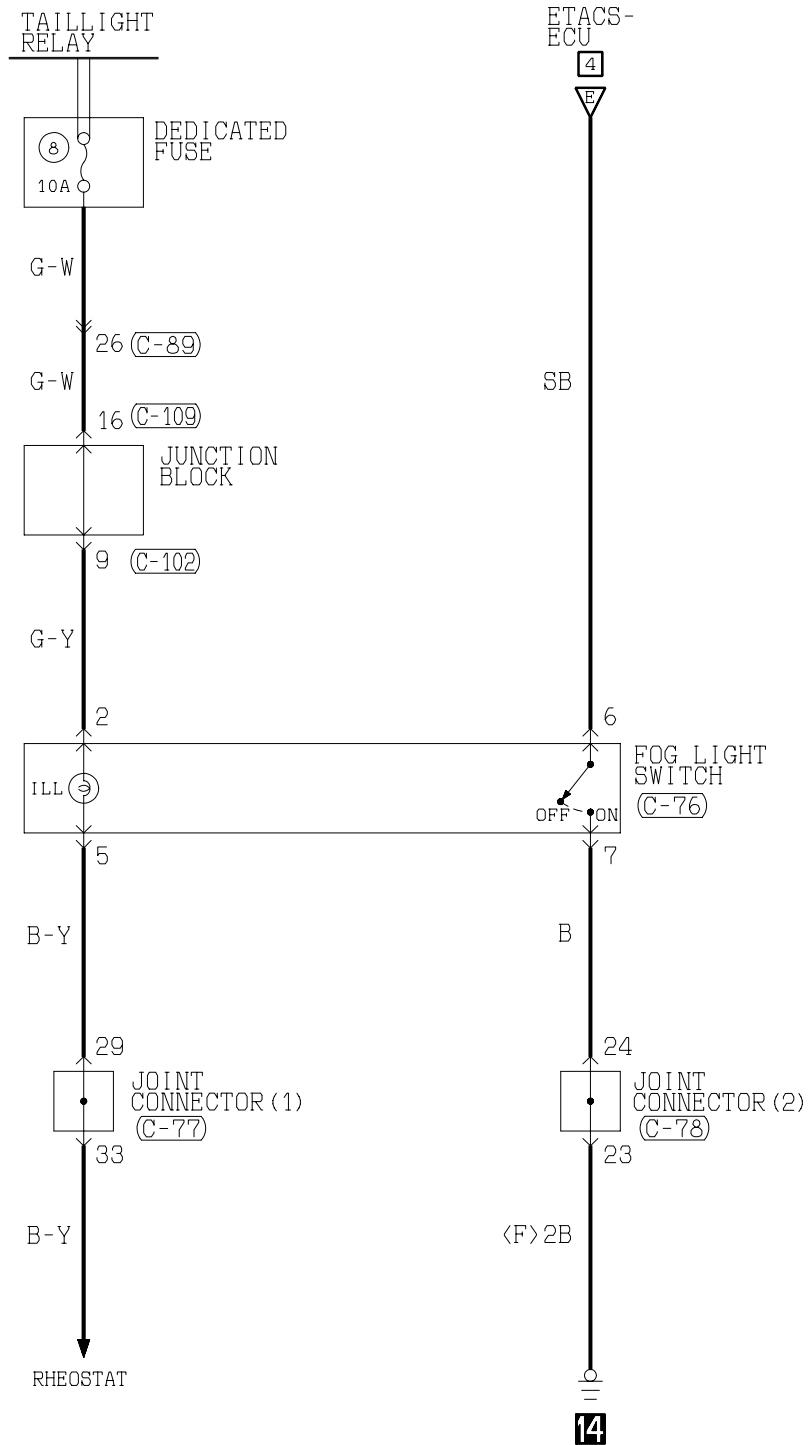

TSB Revision

FOG LIGHT (CONTINUED)

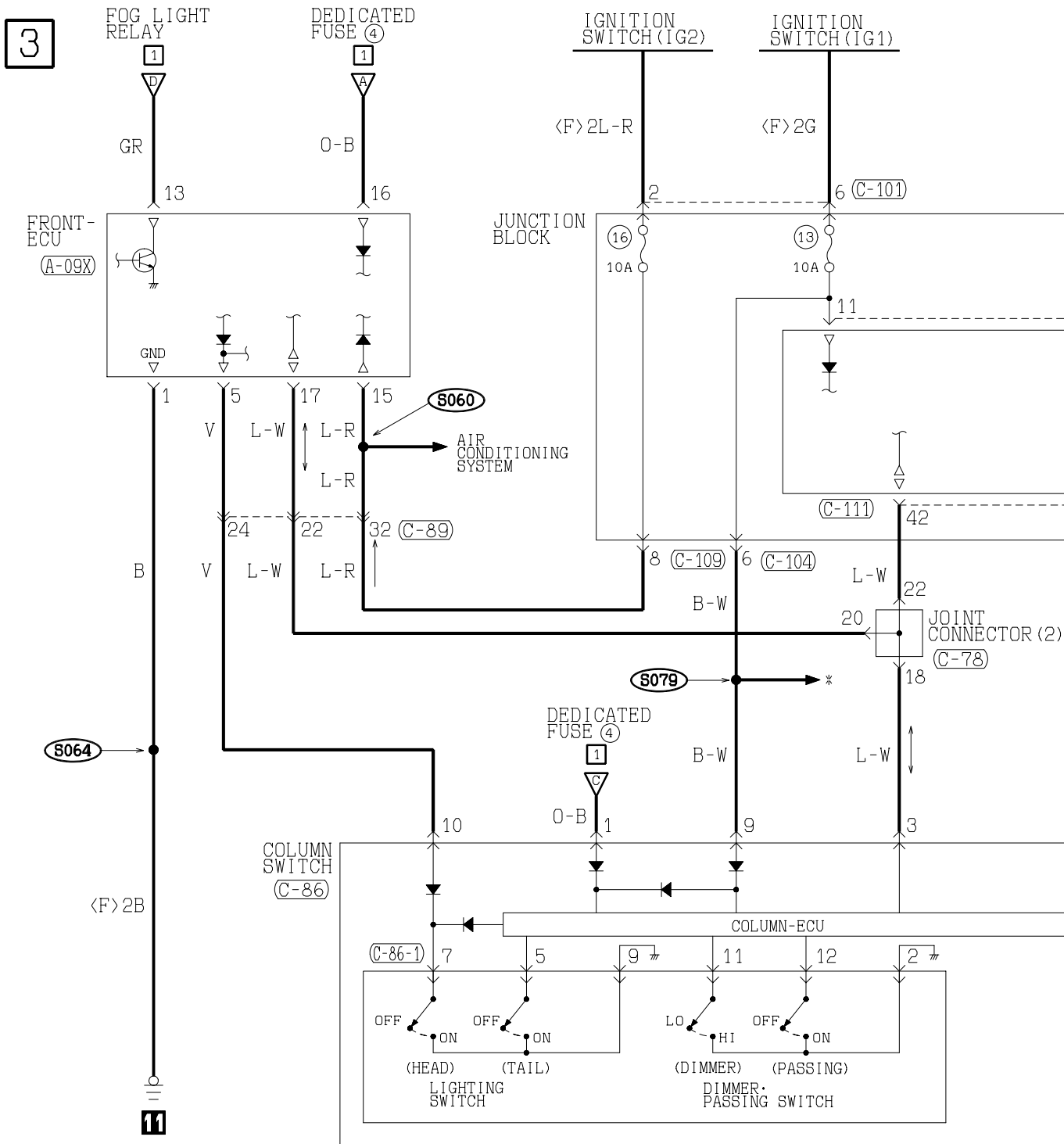

(A-09X)

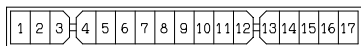

(C-29) FRONT SIDE

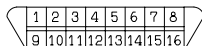

(C-77)

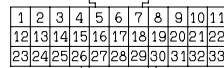

(C-78)

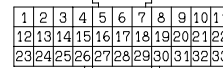

(C-86)

(MU801514)

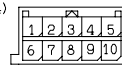

(C-110)



(C-111) (MU801584)



(C-114)

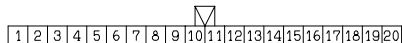

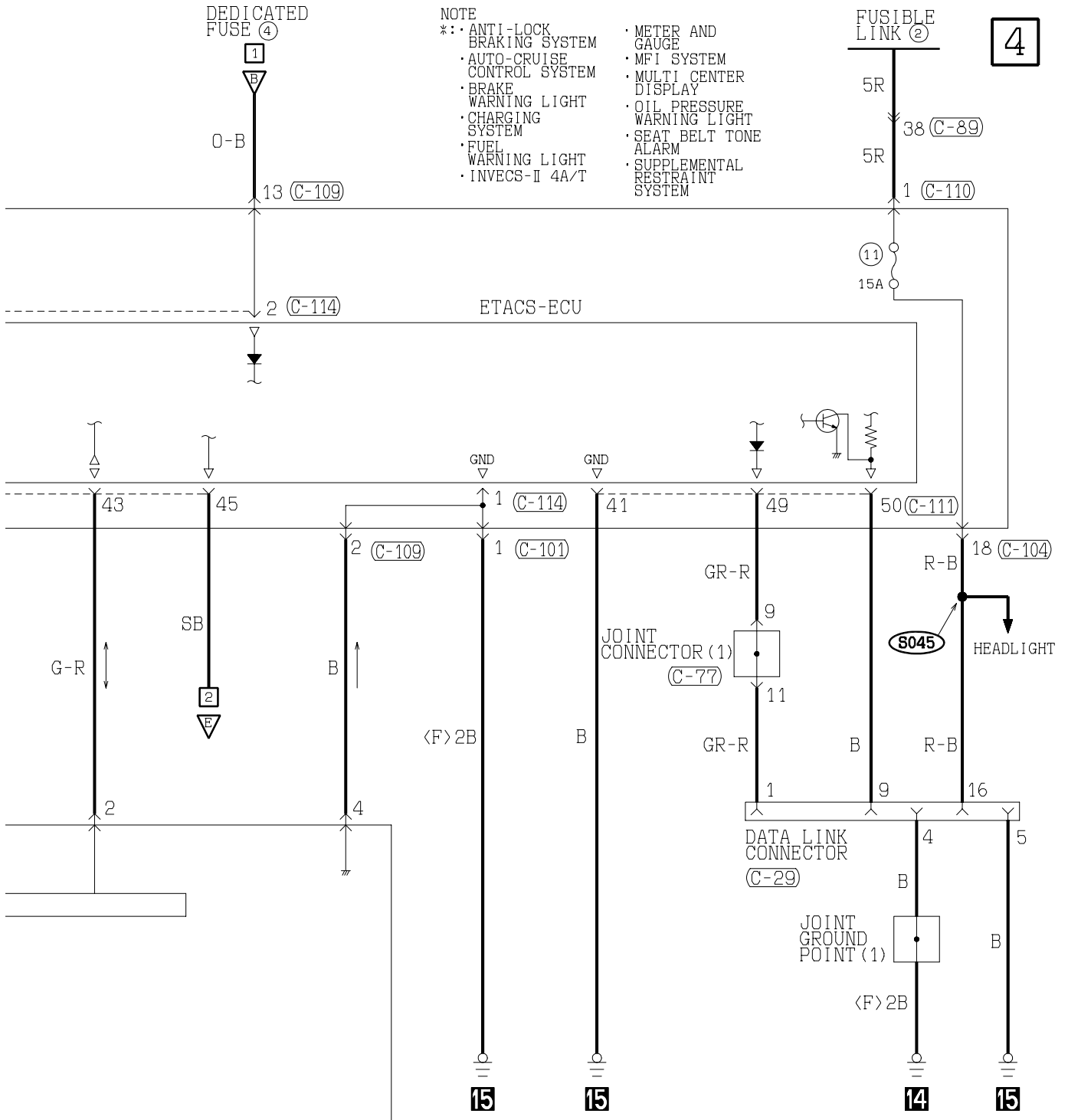

(C-86-1)

1	2	3	4	5	6	7	8	9	10	11	12
---	---	---	---	---	---	---	---	---	----	----	----

(C-89)

1	2	3	4	5	6	7	8	9	10	11	12	13
14	15	16	17	18	19	20	21	22	23	24	25	
26	27	28	29					30	31			38
32	33	34		35		36	37					

(C-101)

MU801331

1	2
3	4
5	6

(C-104)

MU801457

1	2	3	4	5	6	7	8	9
10	11	12	13	14	15	16	17	18
19	20							

(C-109)

1	2	3	4	5	6	7	8
9	10	11	12	13	14	15	16
17	18						

# DOME LIGHT AND LUGGAGE COMPARTMENT LIGHT <ECLIPSE>

M1901002100056

1

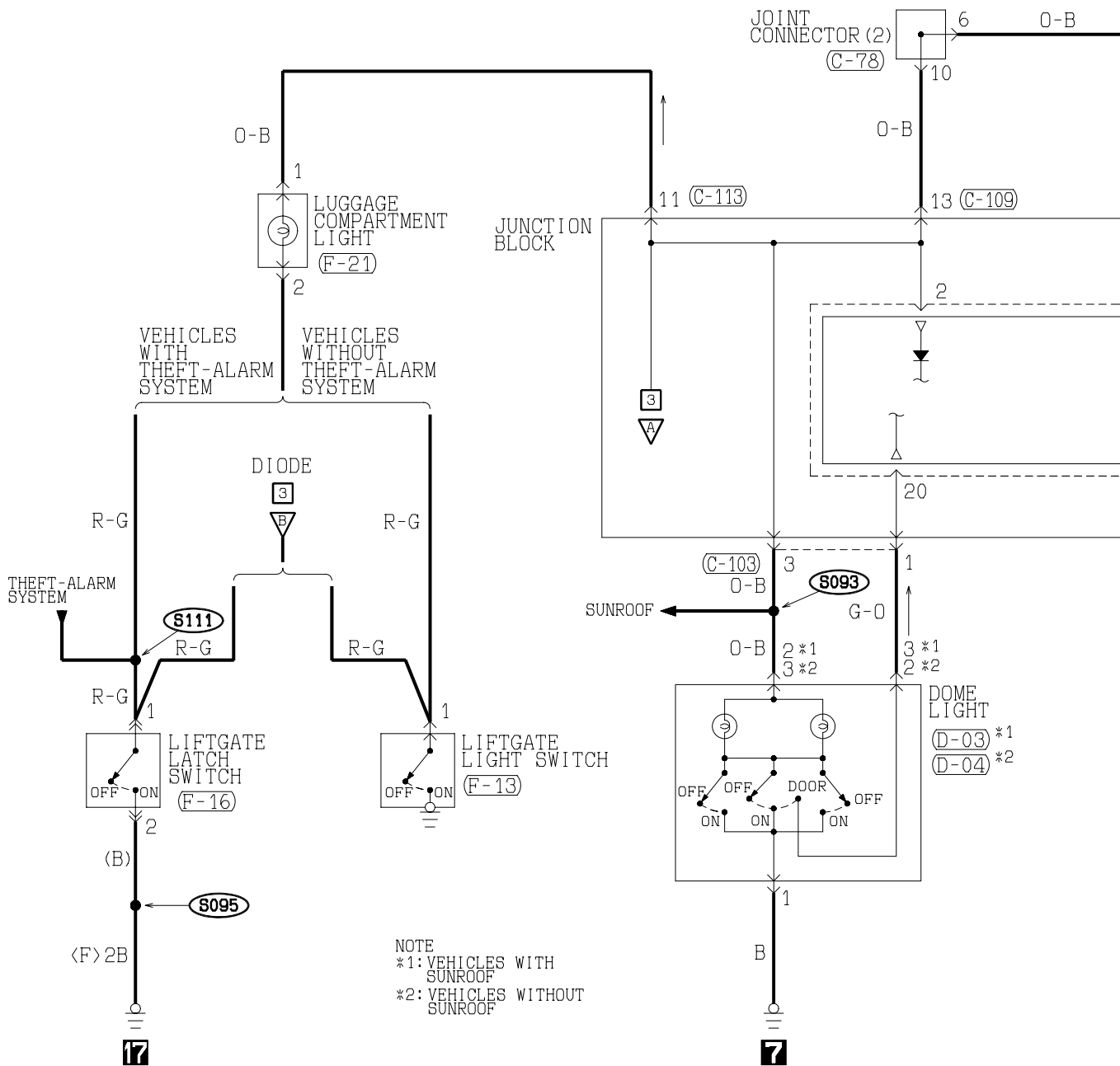

NOTE  
\*1: VEHICLES WITH SUNROOF  
\*2: VEHICLES WITHOUT SUNROOF

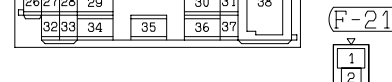
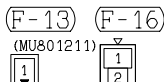
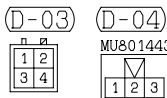
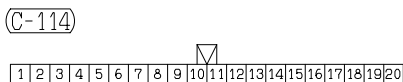
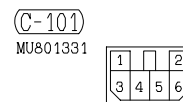
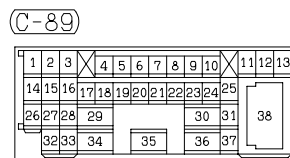
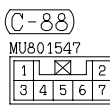
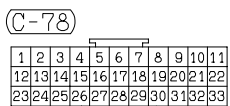
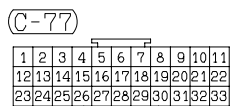

H1S08M13AA

TSB Revision



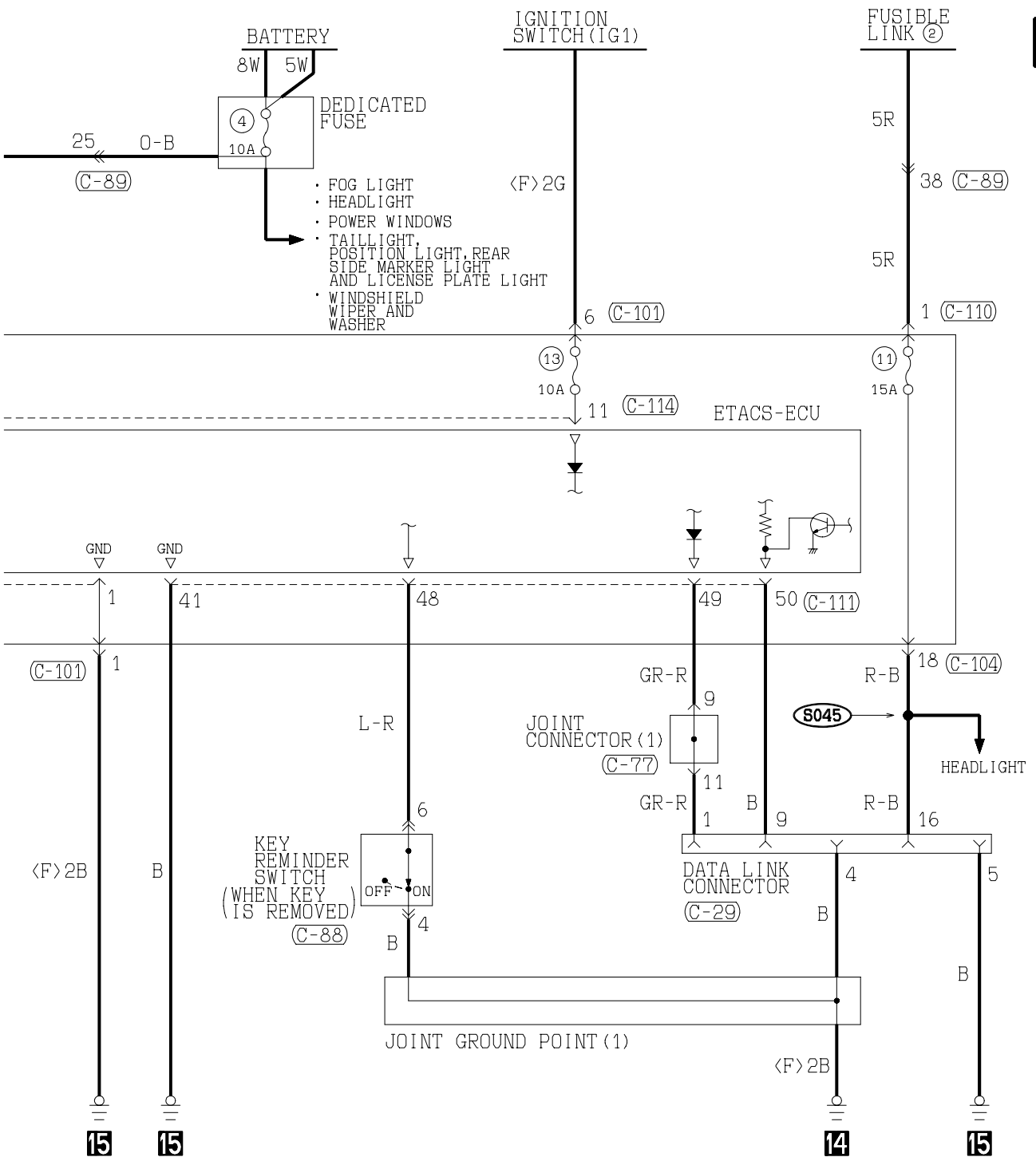

(C-103) MU801447

1	M	2	
3	4	5	6

(C-104) MU801457

1	2	3	4	M	5	6	7	8	9	
10	11	12	13	14	15	16	17	18	19	20

(C-109)

1	2	3	4	M	5	6	7	8	
9	10	11	12	13	14	15	16	17	18

(C-110)

1
---

(C-111) (MU801584)

41	42	43	44	45	46	47	48
49	50	51	52	53	54	55	56

(C-113)

1	2	3	4	M	5	6	7	8	9
10	11	12	13	14	15	16	17	18	19

WIRE COLOR CODE  
 B : BLACK BR : BROWN G : GREEN GR : GRAY L : BLUE LG : LIGHT GREEN O : ORANGE  
 P : PINK R : RED SB : SKY BLUE V : VIOLET W : WHITE Y : YELLOW

DOME LIGHT AND LUGGAGE COMPARTMENT LIGHT <ECLIPSE> (CONTINUED)

3

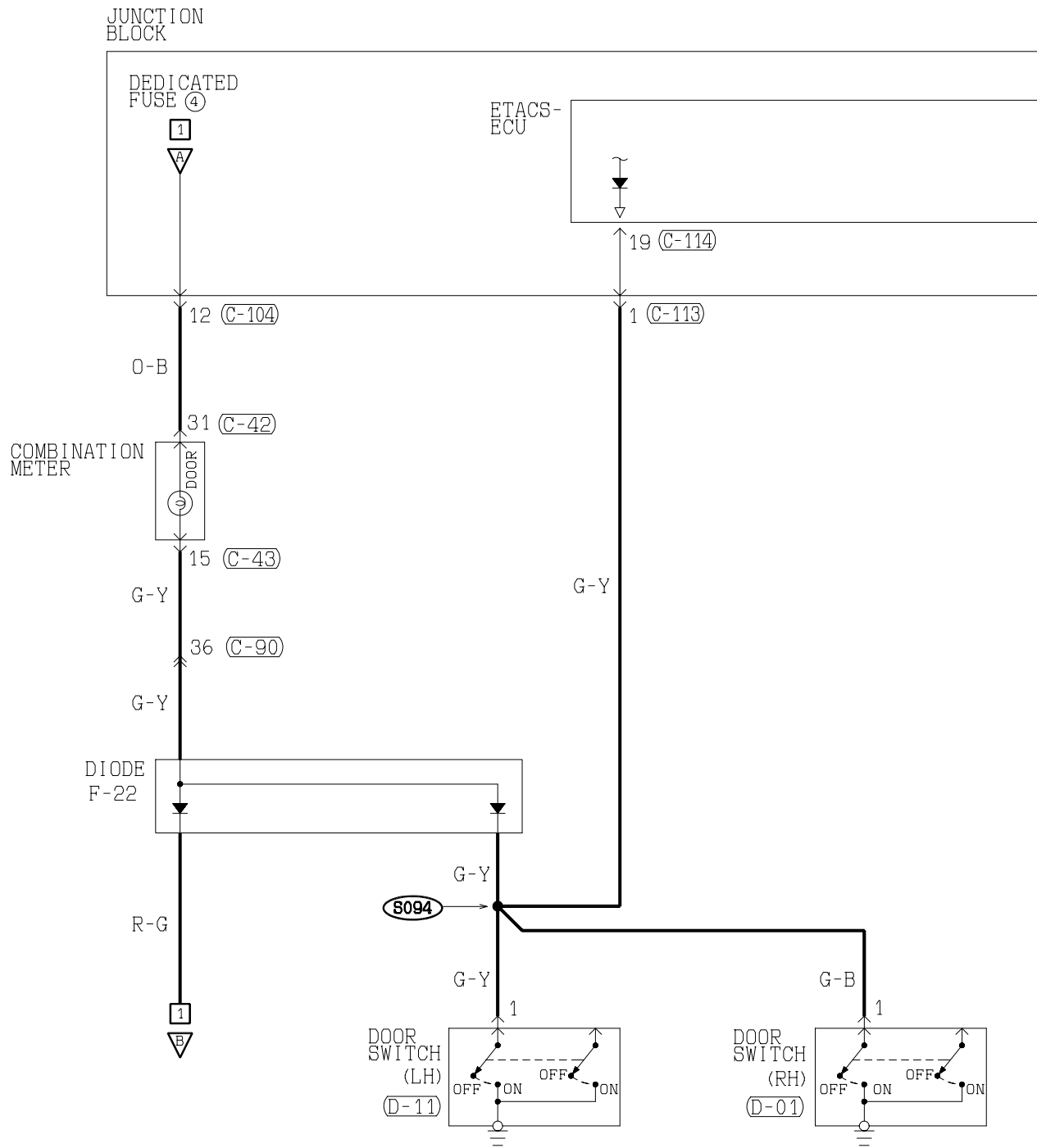

(C-42)

21	22	23	24	25	26	27	28	29	30	31	32	33	34
----	----	----	----	----	----	----	----	----	----	----	----	----	----

(C-43)

1	2	3	4	5	6	7	8	9	10	11	12	13	14	15	16
---	---	---	---	---	---	---	---	---	----	----	----	----	----	----	----

(C-90)

1	2	3	4	5	6	7	8	9			
10	11	12	13	14	15	16	17	18	19	20	21
22	23	24	25	26	27	28	29	30	31	32	33
34	35	36	37	38	39	40	41	42	43		

(C-91)

1	2	3	4	5	6	7	8	9			
10	11	12	13	14	15	16	17	18	19	20	21
22	23	24	25	26	27	28	29	30	31	32	

(E-13)

MU802341



H1S08M13BA

TSB Revision

4

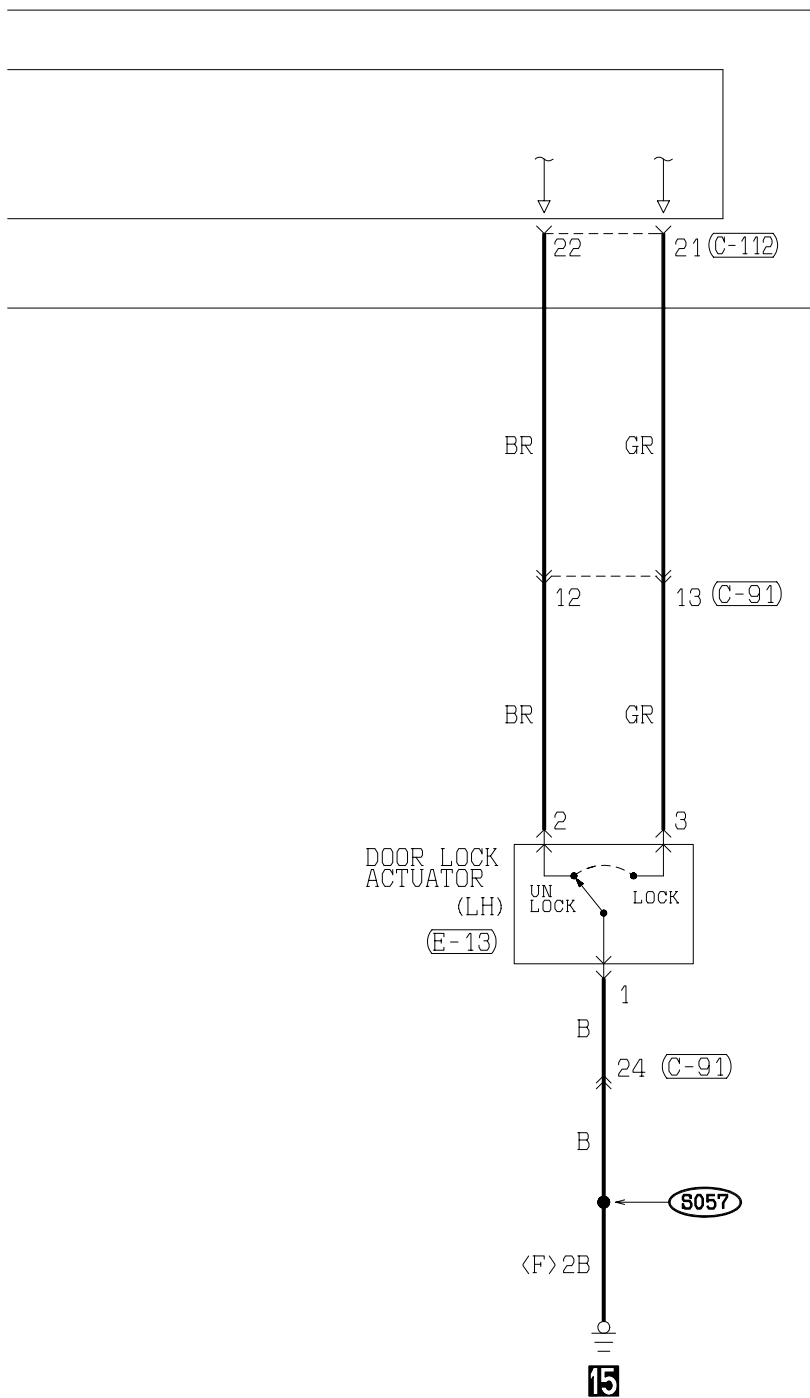

(C-104) MU801457

1	2	3	4	M	5	6	7	8	9	
10	11	12	13	14	15	16	17	18	19	20

(C-112) (MU801585)

21	22	23	24	25	26	27	28	29	30
31	32	33	34	35	36	37	38	39	40

(C-113)

1	2	3	4	M	5	6	7	8	9
10	11	12	13	14	15	16	17	18	19

(C-114)

1	2	3	4	5	6	7	8	9	10	M	12	13	14	15	16	17	18	19	20
---	---	---	---	---	---	---	---	---	----	---	----	----	----	----	----	----	----	----	----

(D-01)

1	2	3
---	---	---

(D-11)

1	2	3
---	---	---

WIRE COLOR CODE  
 B : BLACK BR: BROWN G : GREEN GR: GRAY L : BLUE LG: LIGHT GREEN O : ORANGE  
 P : PINK R : RED SB: SKY BLUE V : VIOLET W : WHITE Y : YELLOW

H1S0&M13BB

**TSB Revision**

# DOME LIGHT AND TRUNK LIGHT <ECLIPSE SPYDER>

1

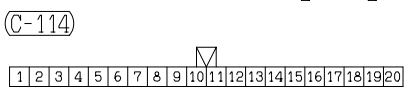
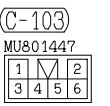
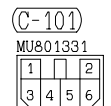
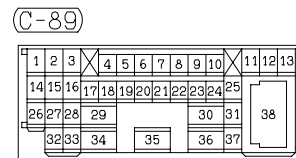
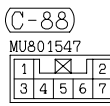
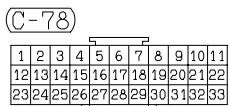
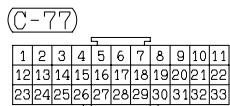
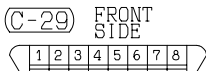
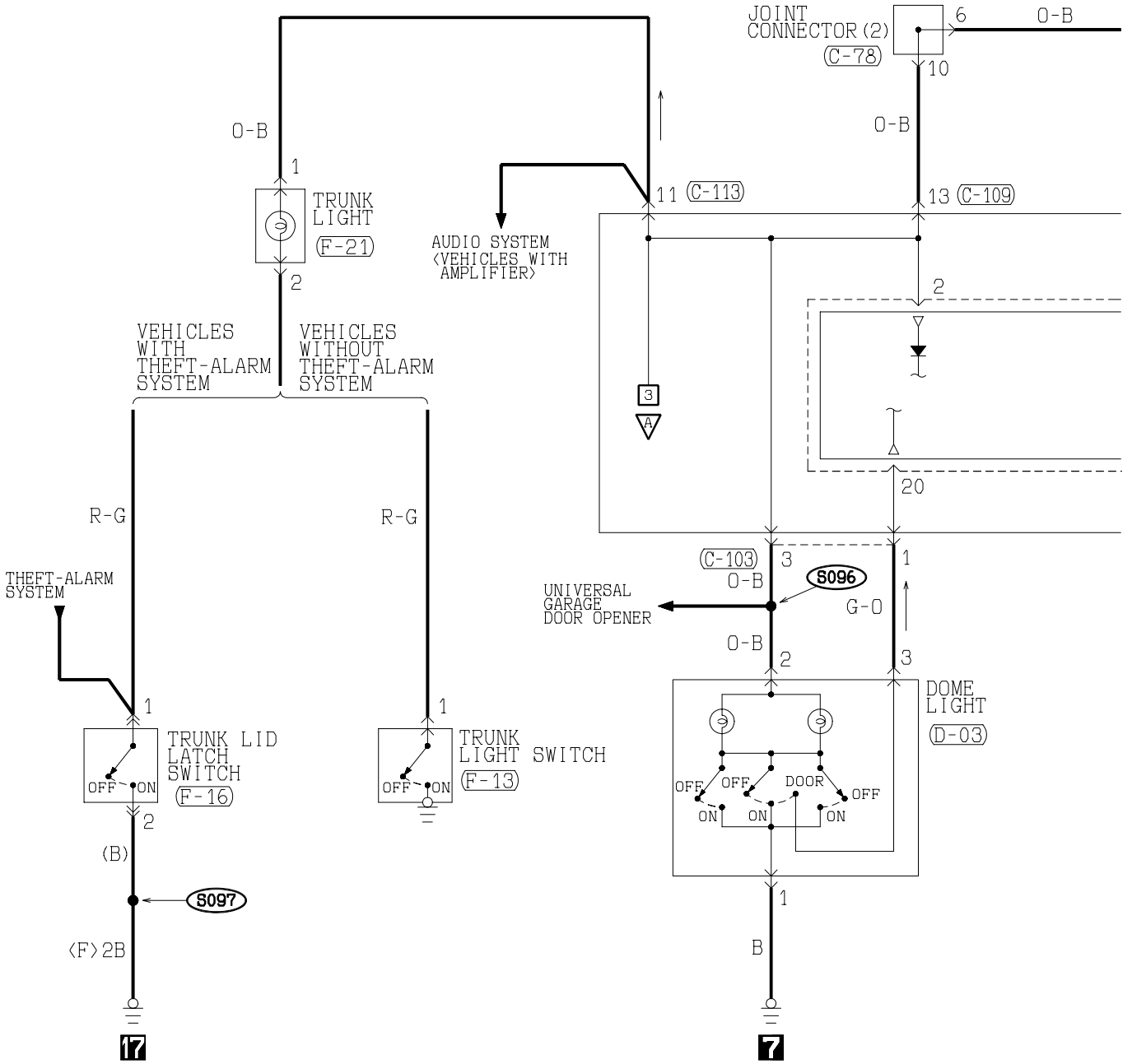

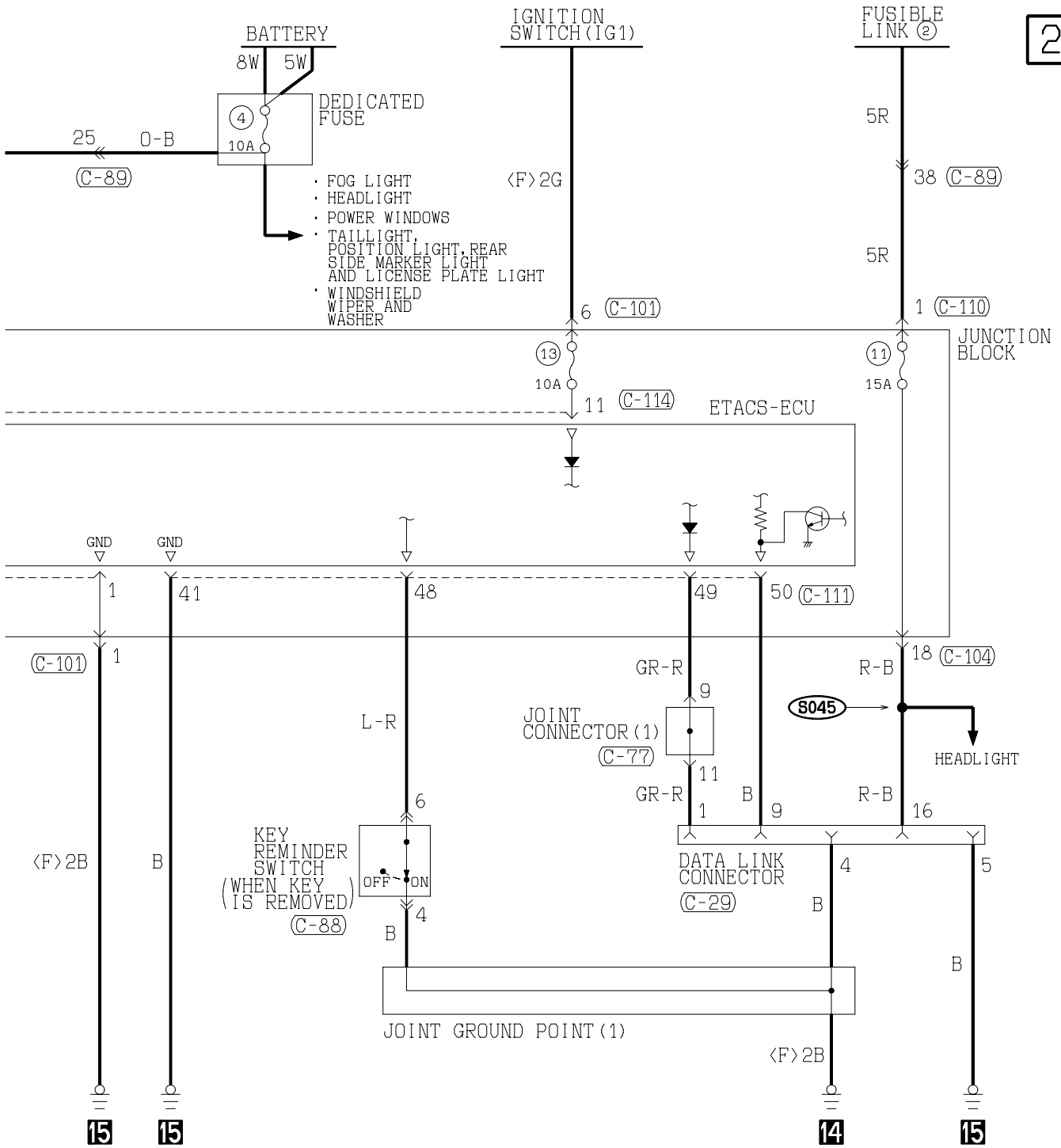

**2**

(C-104)

1	2	3	4	5	6	7	8	9		
10	11	12	13	14	15	16	17	18	19	20

(C-109)

1	2	3	4	5	6	7	8		
9	10	11	12	13	14	15	16	17	18

(C-110)

1
---

(C-111) (MU801584)

41	42	43	44	45	46	47	48
49	50	51	52	53	54	55	56

(C-113)

1	2	3	4	5	6	7	8	9	
10	11	12	13	14	15	16	17	18	19

WIRE COLOR CODE  
 B : BLACK BR : BROWN G : GREEN GR : GRAY L : BLUE LG : LIGHT GREEN O : ORANGE  
 P : PINK R : RED SB : SKY BLUE V : VIOLET W : WHITE Y : YELLOW

H1S08M14AB

**TSB Revision**

DOME LIGHT AND TRUNK LIGHT <ECLIPSE SPYDER> (CONTINUED)

3

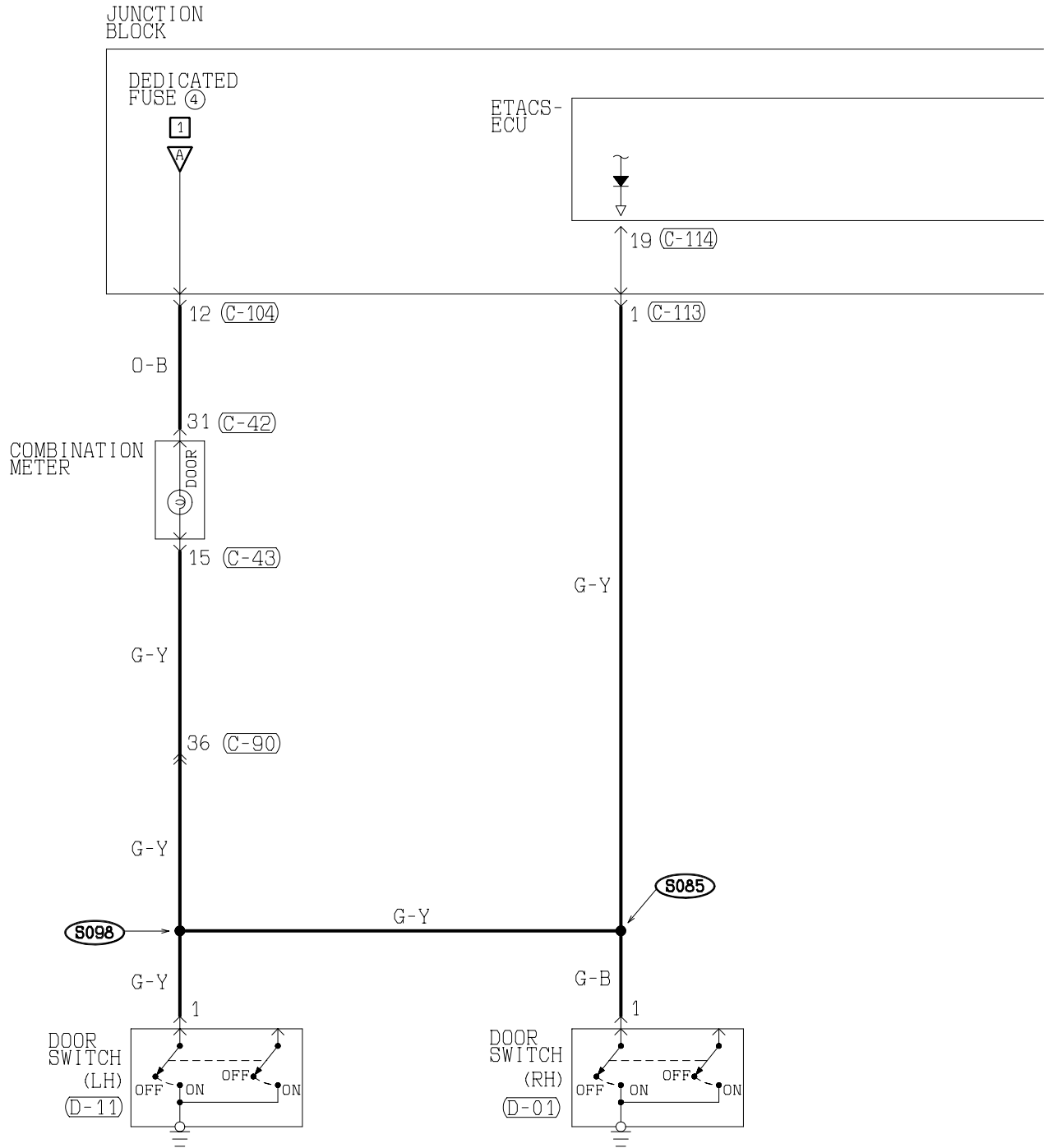

(C-42)

21	22	23	24	25	26	27	28	29	30	31	32	33	34
----	----	----	----	----	----	----	----	----	----	----	----	----	----

(C-43)

1	2	3	4	5	6	7	8	9	10	11	12	13	14	15	16
---	---	---	---	---	---	---	---	---	----	----	----	----	----	----	----

(C-90)

1	2	3	4	5	6	7	8	9
10	11	12	13	14	15	16	17	18
19	20	21	22	23	24	25	26	27
28	29	30	31	32	33	34	35	36
37	38	39	40	41	42	43		

(C-91)

1	2	3	4	5	6	7	8	9
10	11	12	13	14	15	16	17	18
19	20	21	22	23	24	25	26	27
28	29	30	31	32				

(E-13)

MU802341



H1S08M14BA

TSB Revision

4

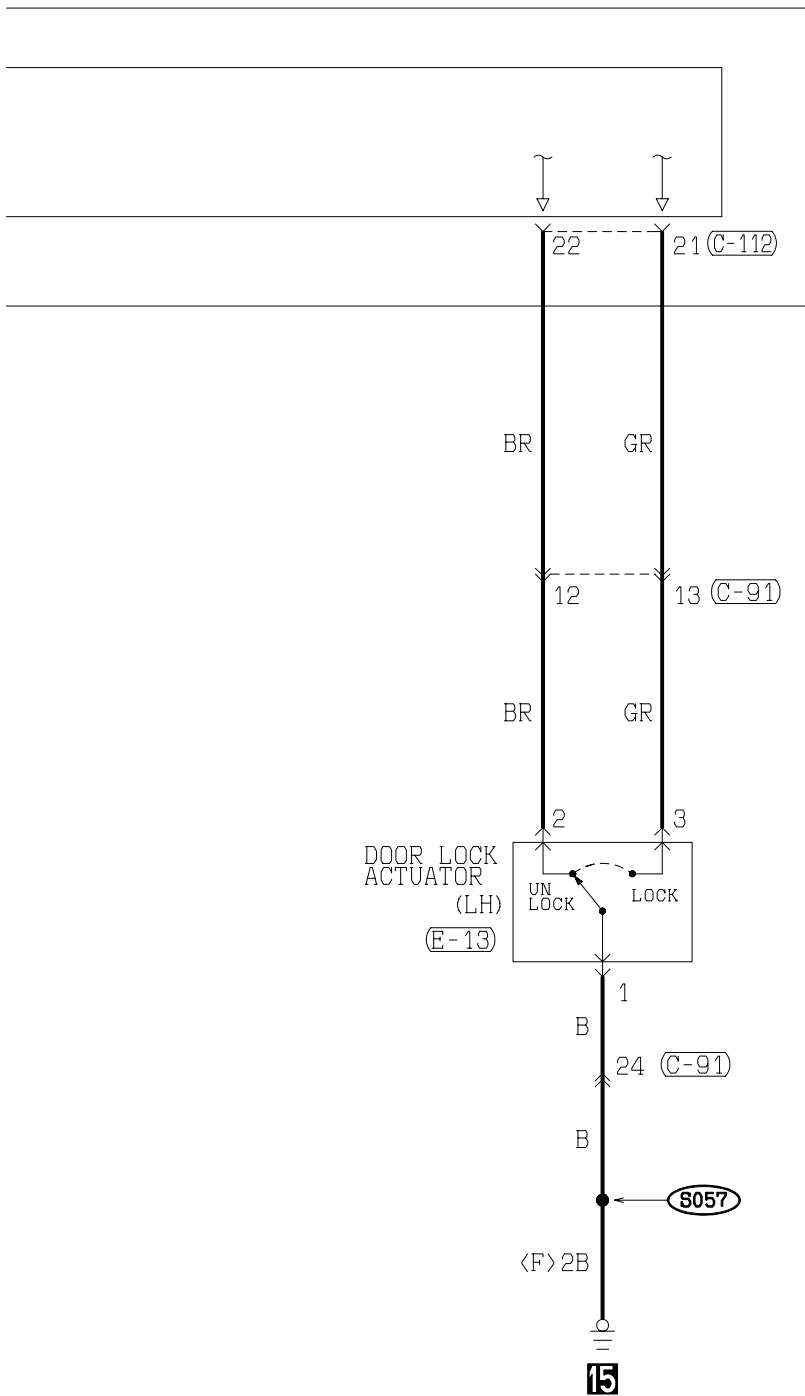

(C-104)  
 MU801457

1	2	3	4	M	5	6	7	8	9	
10	11	12	13	14	15	16	17	18	19	20

(C-112) (MU801585)

21	22	23	24	25	26	27	28	29	30
31	32	33	34	35	36	37	38	39	40

(C-113)

1	2	3	4	M	5	6	7	8	9
10	11	12	13	14	15	16	17	18	19

(C-114)

1	2	3	4	5	6	7	8	9	10	M	11	12	13	14	15	16	17	18	19	20
---	---	---	---	---	---	---	---	---	----	---	----	----	----	----	----	----	----	----	----	----

(D-01)

1	2	3
---	---	---

(D-11)

1	2	3
---	---	---

WIRE COLOR CODE  
 B : BLACK BR: BROWN G : GREEN GR: GRAY L : BLUE LG: LIGHT GREEN O : ORANGE  
 P : PINK R : RED SB: SKY BLUE V : VIOLET W : WHITE Y : YELLOW

H1S08M14BB

TSB Revision

# TURN-SIGNAL LIGHT AND HAZARD WARNING LIGHT

M1901002900104

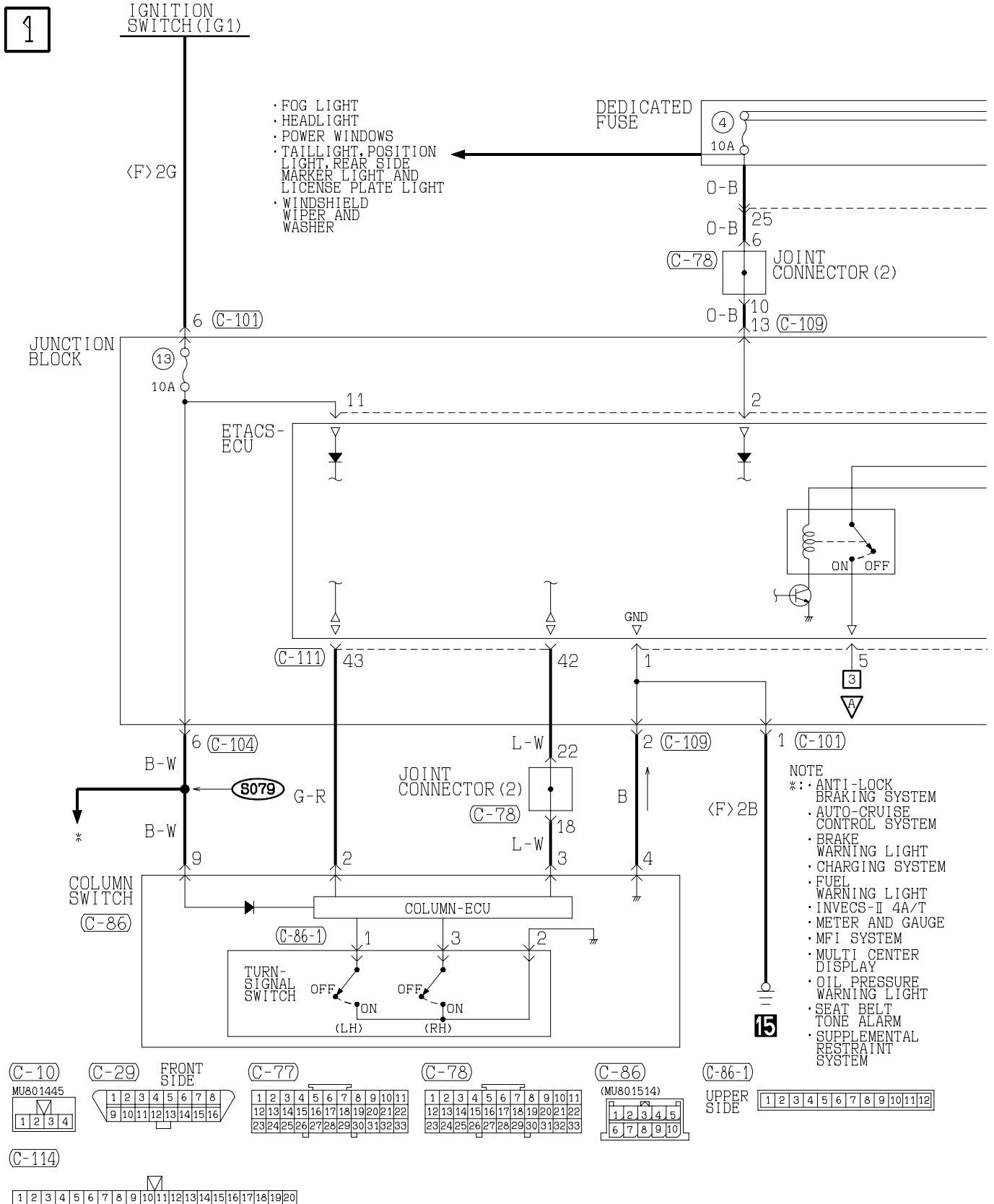

H1809M09AA



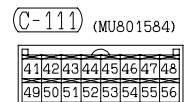
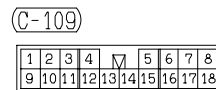
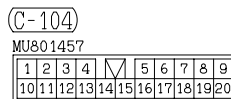
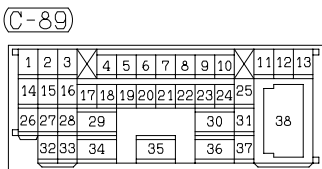
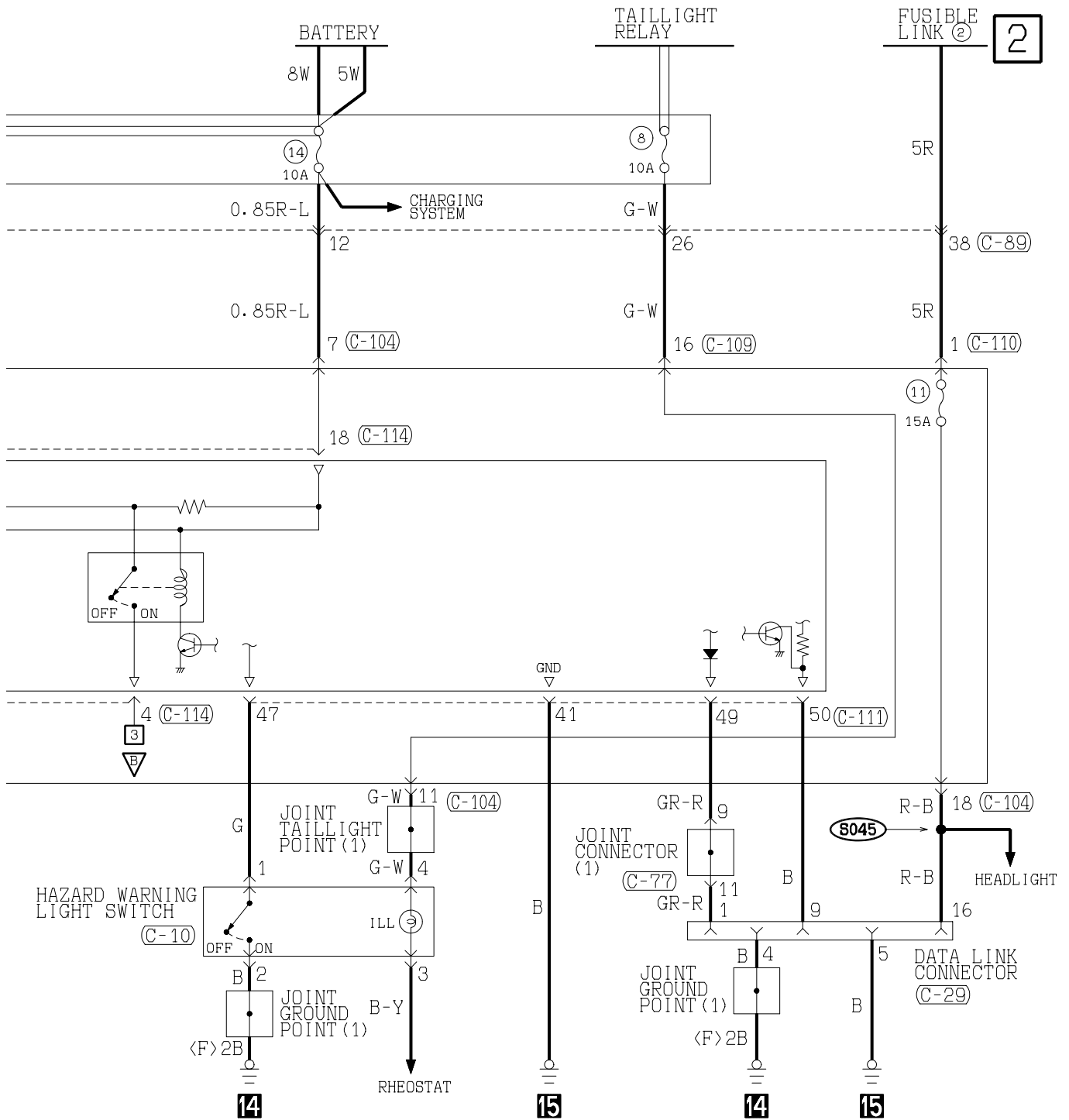

Wire colour code  
 B : Black  
 BR : Brown  
 W : White  
 V : Violet  
 LG : Light green  
 O : Orange  
 SB : Sky blue  
 G : Green  
 GR : Gray  
 P : Pink  
 L : Blue  
 R : Red  
 Y : Yellow

H1S09M09AB

**TSB Revision**

TURN-SIGNAL LIGHT AND HAZARD WARNING LIGHT (CONTINUED)

3

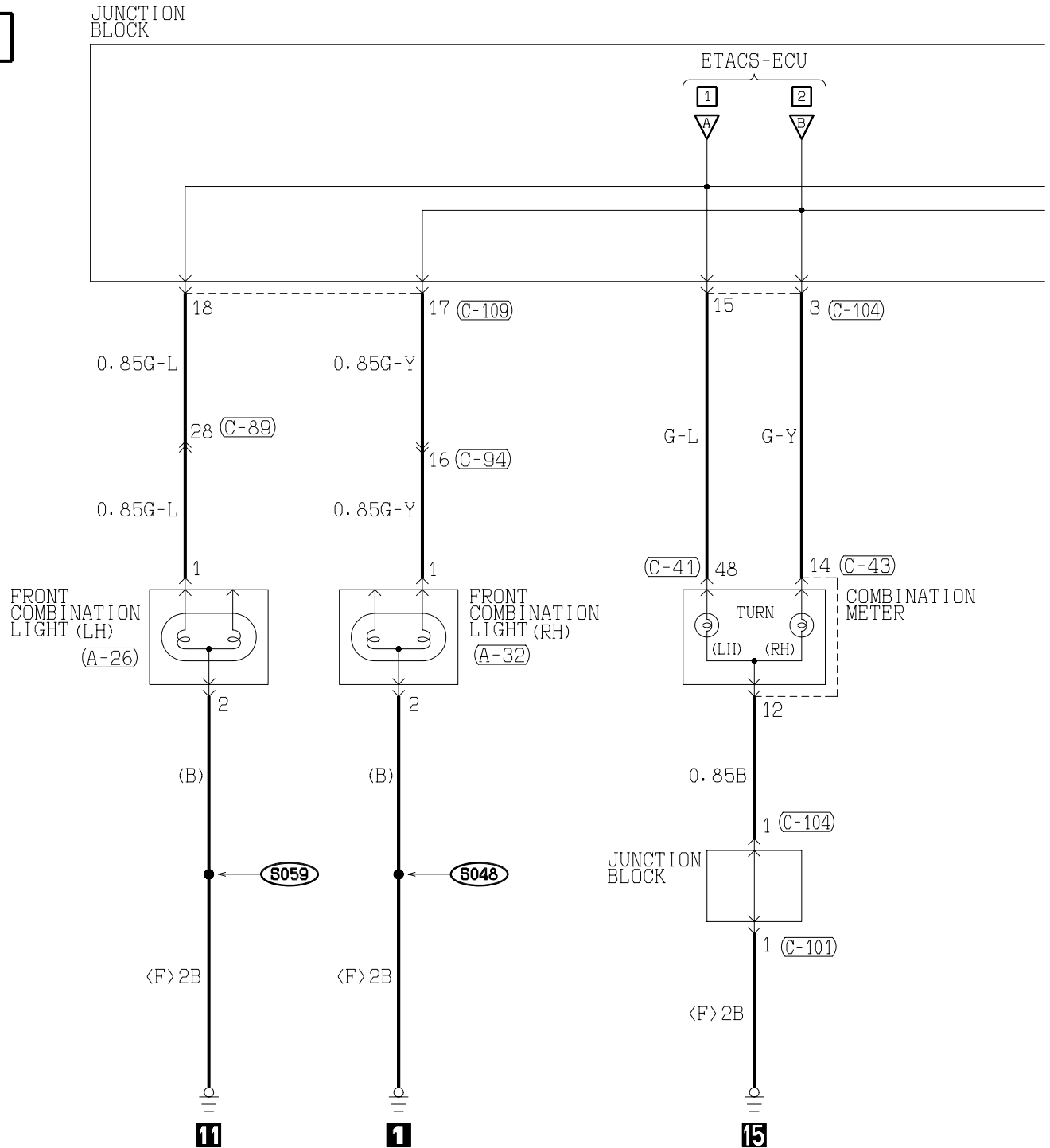

(A-26) (A-32) (C-41)



(C-43)

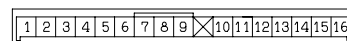

(C-89)

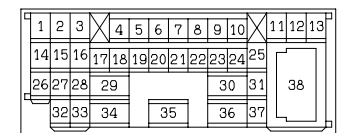

(C-109)

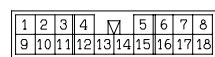

(F-09)



(F-17)



TSB Revision

4

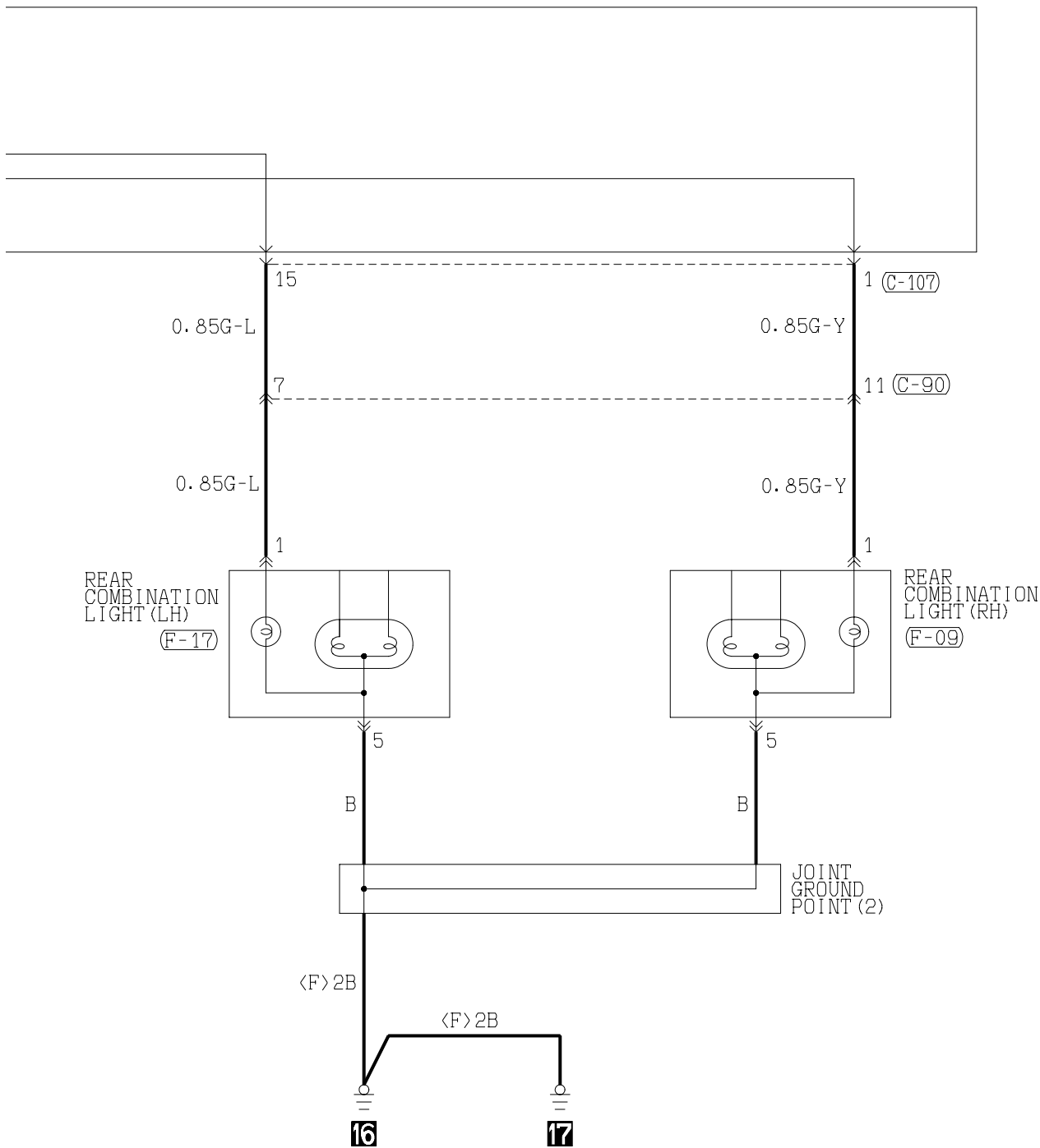

(C-90)

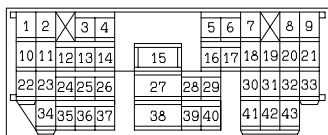

(C-94)

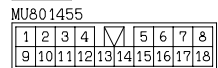

(C-101)

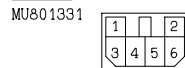

(C-104)

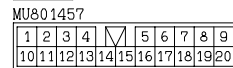

(C-107)

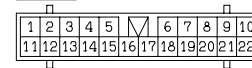

WIRE COLOR CODE  
 B : BLACK BR : BROWN G : GREEN GR : GRAY  
 L : BLUE LG : LIGHT GREEN O : ORANGE P : PINK  
 R : RED SB : SKY BLUE V : VIOLET W : WHITE  
 Y : YELLOW

H1S09M09BB

TSB Revision

# STOPLIGHT

1

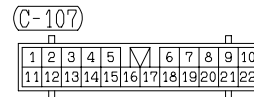
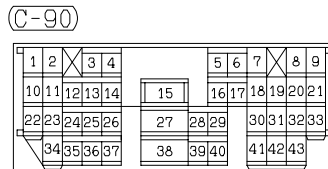
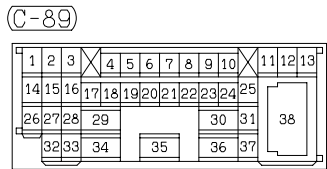
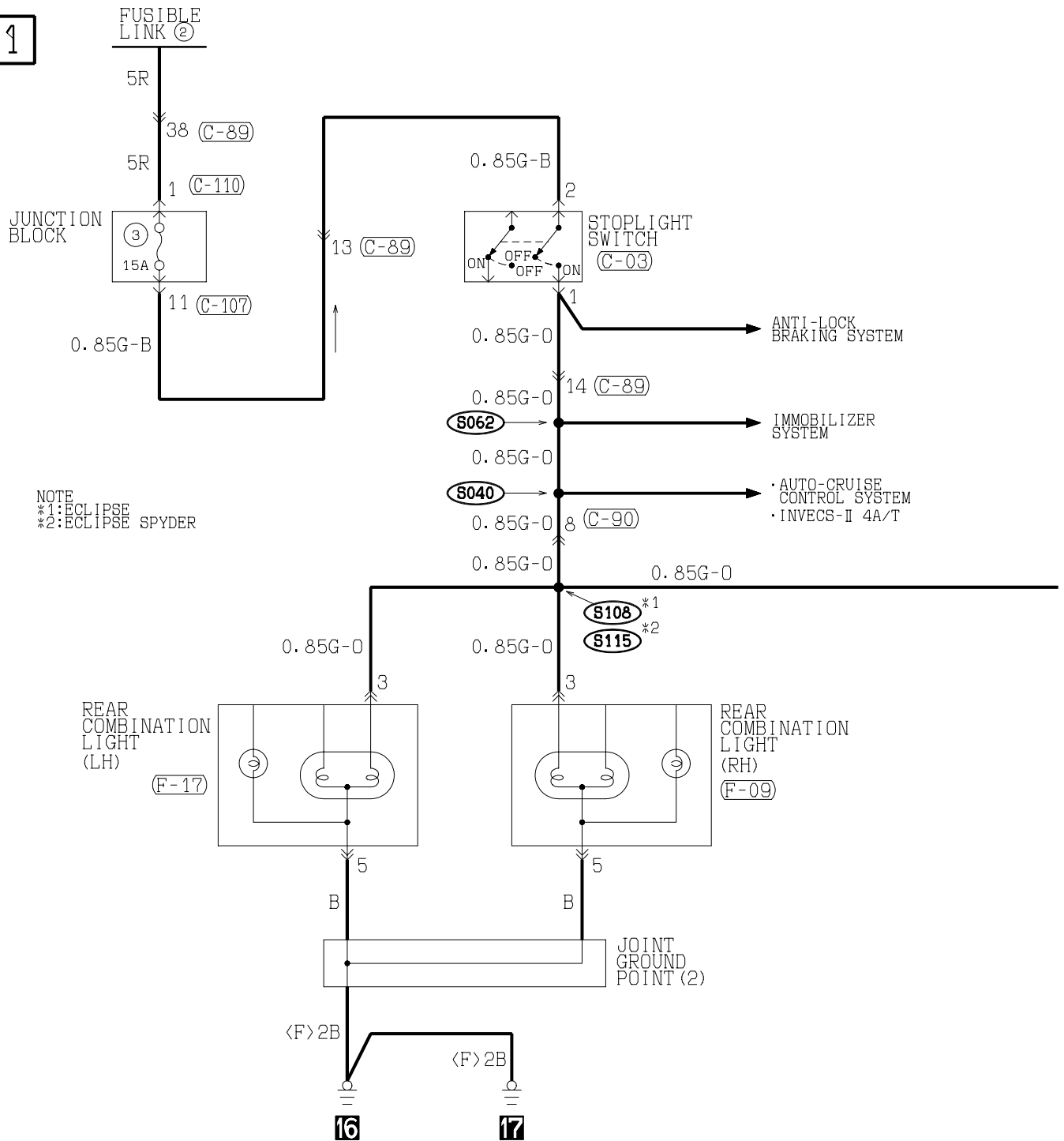

TSB Revision

2

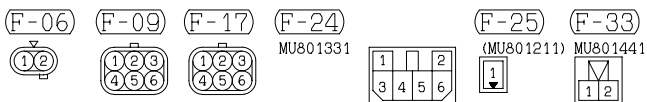
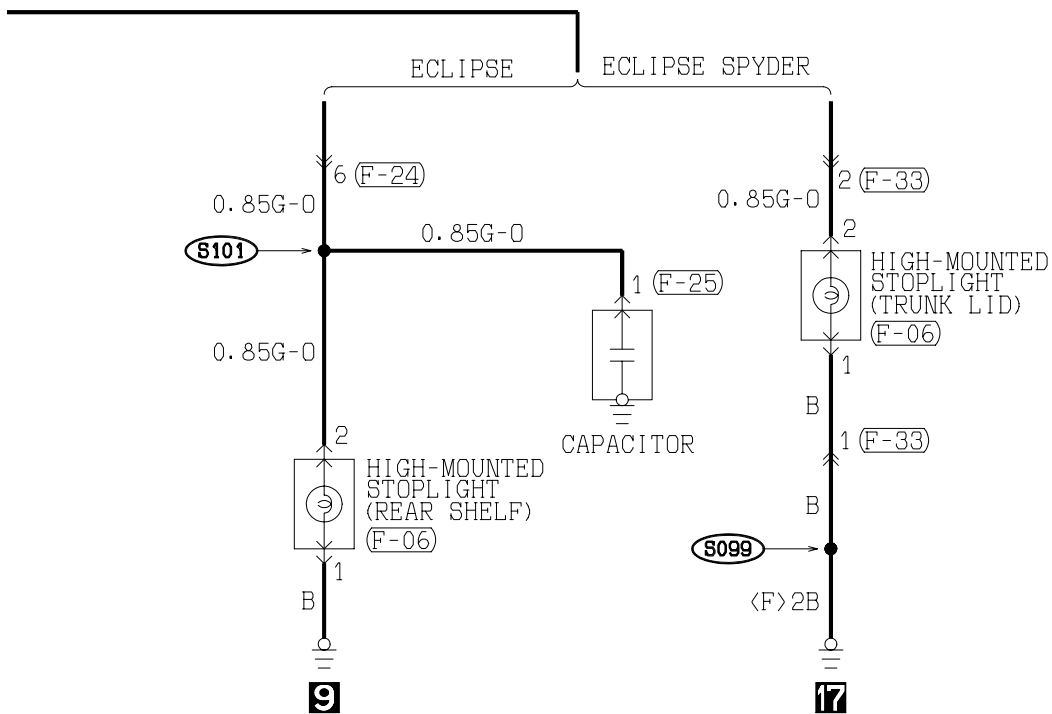

WIRE COLOR CODE  
 B :BLACK LG:LIGHT GREEN G :GREEN L :BLUE W :WHITE Y :YELLOW SB:SKY BLUE  
 BR:BROWN O :ORANGE GR:GRAY R :RED P :PINK V :VIOLET

H1S09M10AA

TSB Revision

# BACKUP LIGHT <M/T>

M1901003100093

1

NOTE  
\*1: ECLIPSE  
\*2: ECLIPSE SPYDER

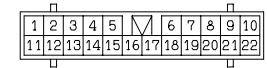
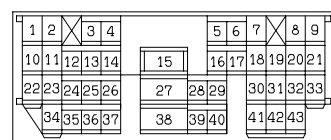
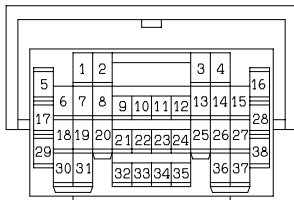
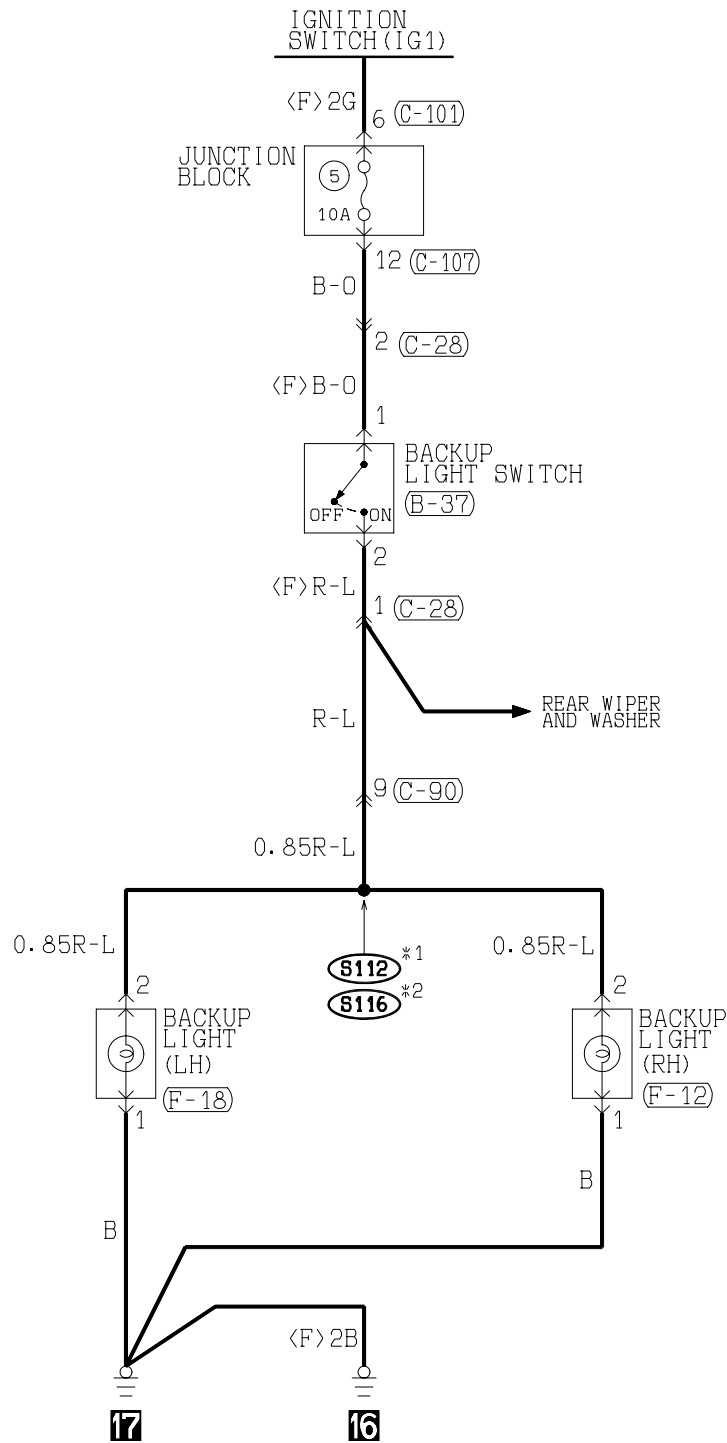

H1S09M11AA

TSB Revision

BACKUP LIGHT <A/T>

M1901003100101

1

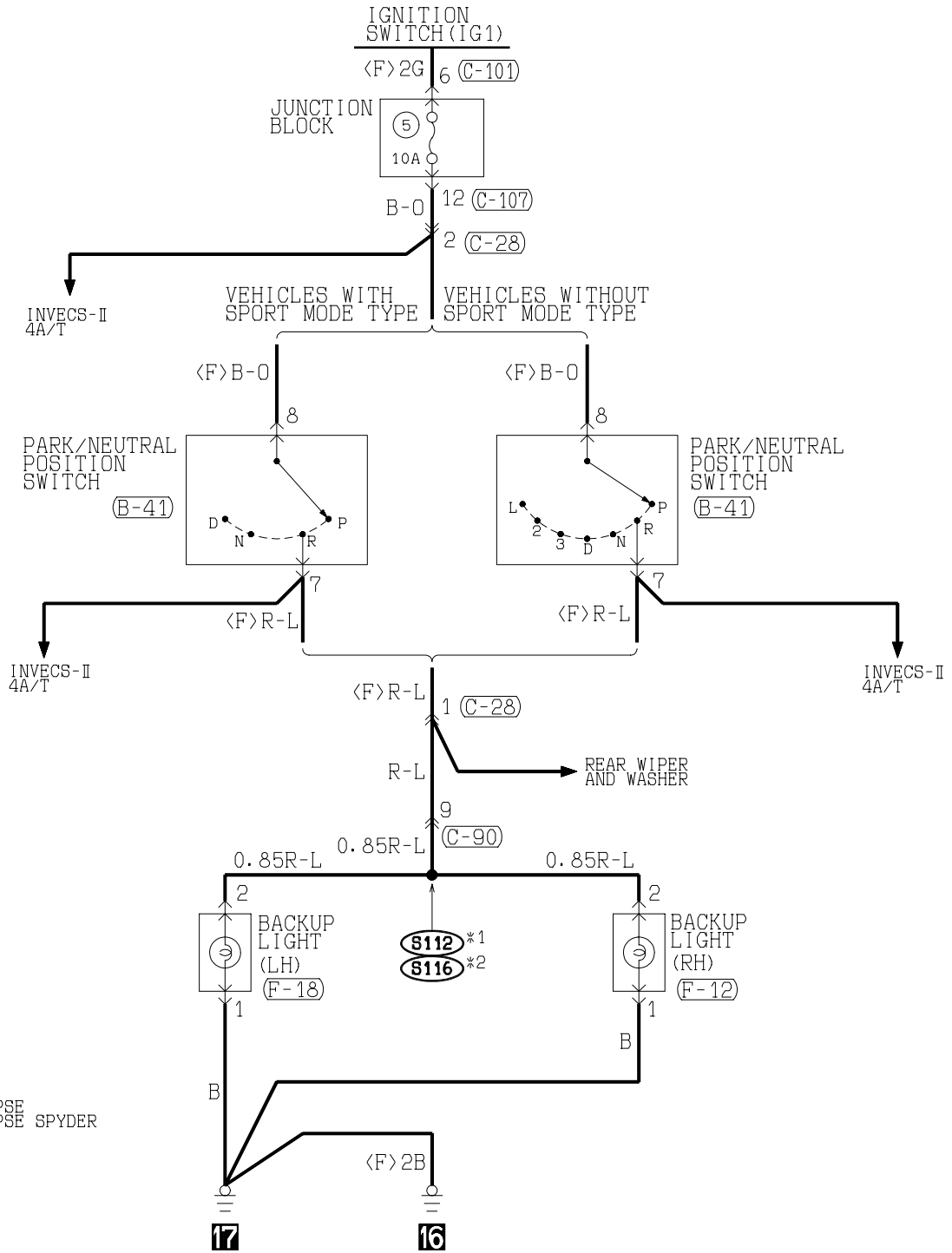

NOTE  
\*1: ECLIPSE  
\*2: ECLIPSE SPYDER

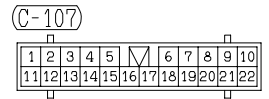
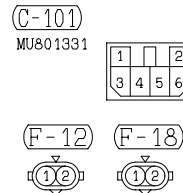
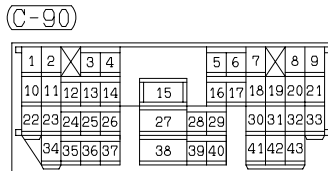
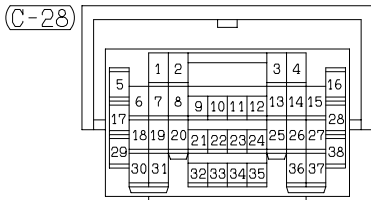
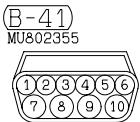

H1S09M12AB

TSB Revision

# HORN

1

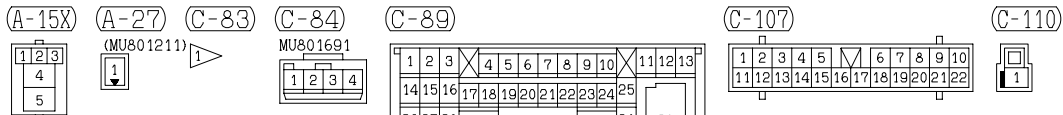
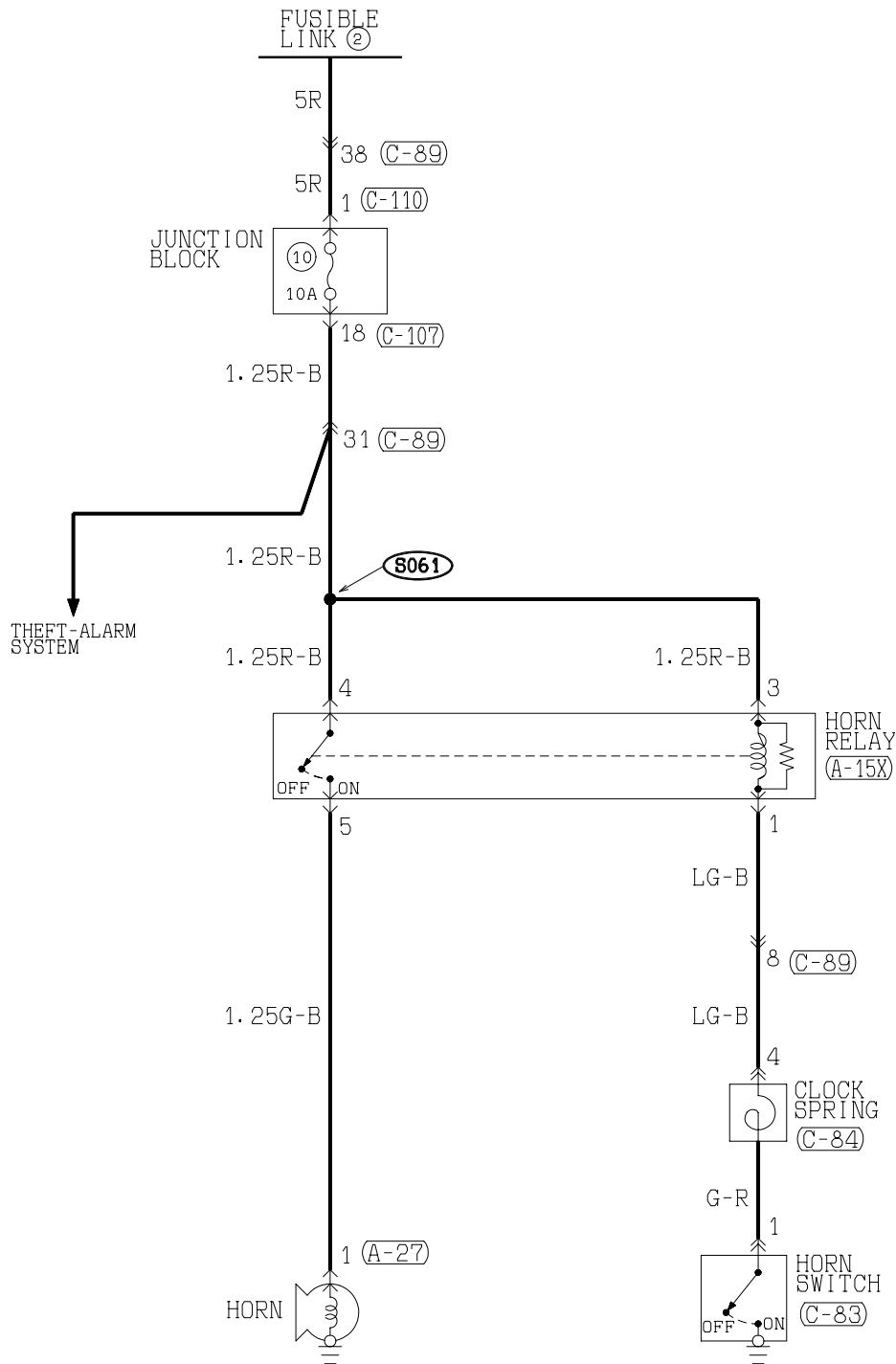

WIRE COLOR CODE  
 B : BLACK BR : BROWN G : GREEN GR : GRAY L : BLUE LG : LIGHT GREEN O : ORANGE  
 P : PINK R : RED SB : SKY BLUE V : VIOLET W : WHITE Y : YELLOW

H1509M13AA

TSB Revision



NOTES

TSB Revision

# METER AND GAUGE

M1901003500079

1

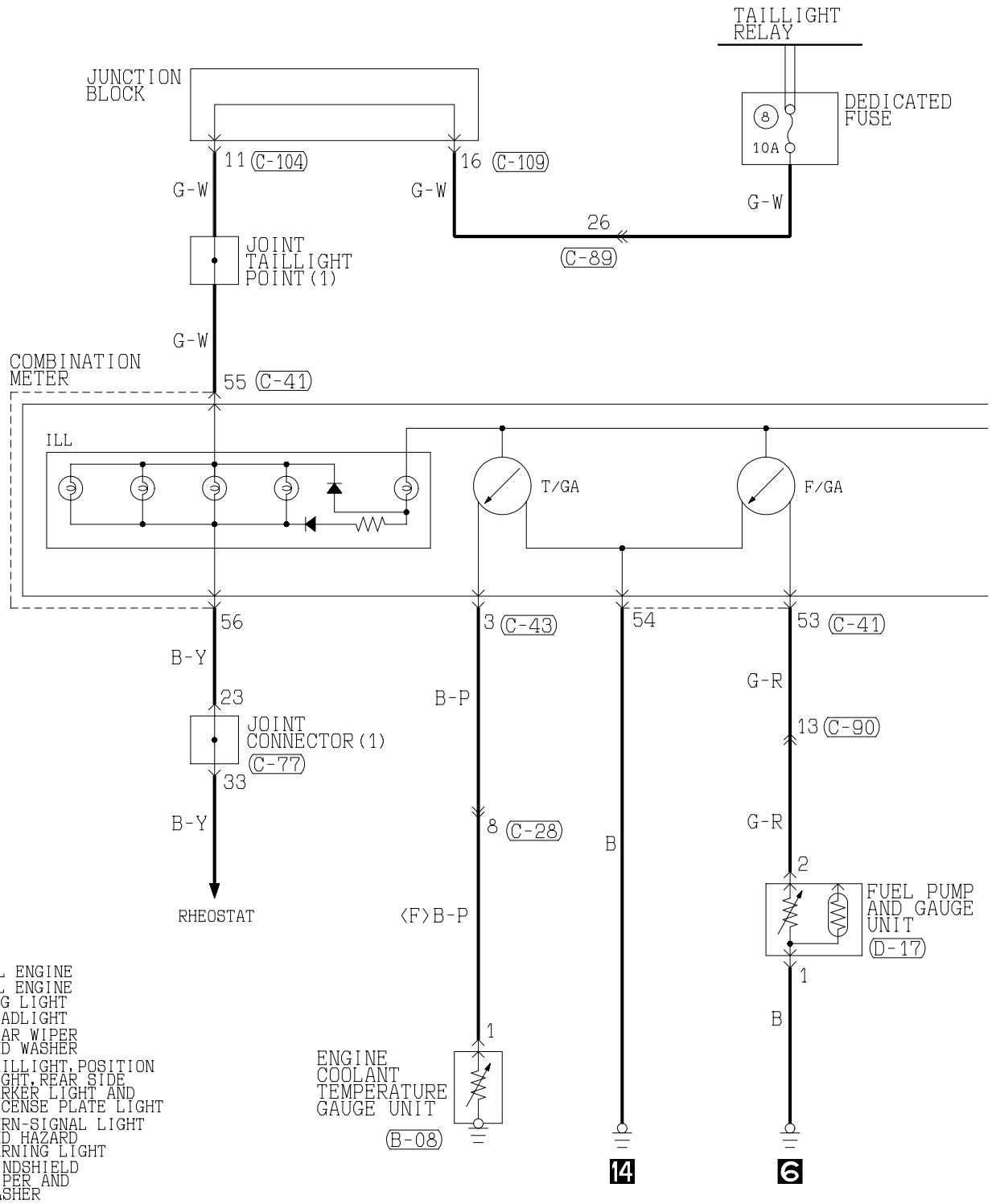

NOTE

- \*1: 2.4L ENGINE
- \*2: 3.0L ENGINE
- \*3: FOG LIGHT
- HEADLIGHT
- REAR WIPER AND WASHER
- TAILLIGHT, POSITION LIGHT, REAR SIDE MARKER LIGHT AND LICENSE PLATE LIGHT
- TURN-SIGNAL LIGHT AND HAZARD WARNING LIGHT
- WINDSHIELD WIPER AND WASHER

(B-08)

(B-36)

(B-39)

(C-28)

(C-41)

1

1 2 3

1 2 3

(C-89)

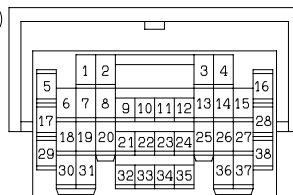
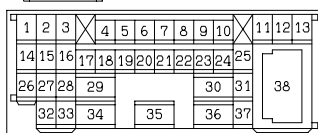

41 42 43 44 45 46 47 48 49 50 51 52 53 54 55 56

(C-90)

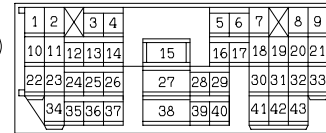

H1S10M04AA

TSB Revision

2

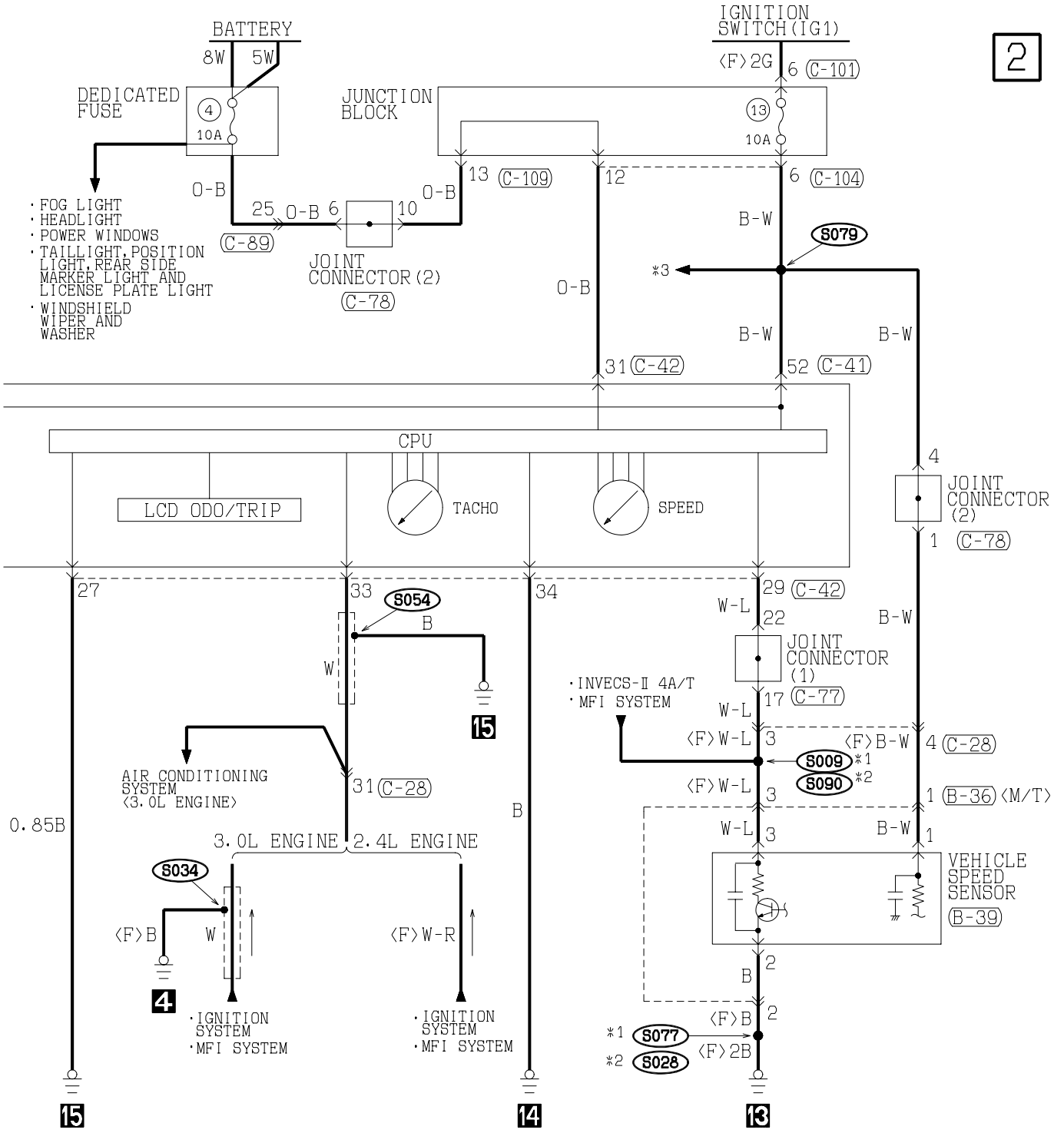

C-42

21	22	23	24	25	26	27	28	29	30	31	32	33	34
----	----	----	----	----	----	----	----	----	----	----	----	----	----

C-43

1	2	3	4	5	6	7	8	9	10	11	12	13	14	15	16
---	---	---	---	---	---	---	---	---	----	----	----	----	----	----	----

C-77

1	2	3	4	5	6	7	8	9	10	11
12	13	14	15	16	17	18	19	20	21	22
23	24	25	26	27	28	29	30	31	32	33

C-78

1	2	3	4	5	6	7	8	9	10	11
12	13	14	15	16	17	18	19	20	21	22
23	24	25	26	27	28	29	30	31	32	33

C-101

MU801331

1	2
3	4

C-104

MU801457

1	2	3	4	5	6	7	8	9
10	11	12	13	14	15	16	17	18
19	20							

C-109

1	2	3	4	5	6	7	8
9	10	11	12	13	14	15	16
17	18						

D-17

(MU802058)

1	2	3
4	5	

TSB Revision

# BRAKE WARNING LIGHT, OIL PRESSURE WARNING LIGHT, FUEL WARNING LIGHT

M1901011800075

1

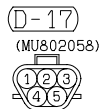
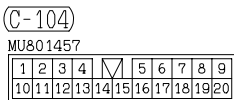
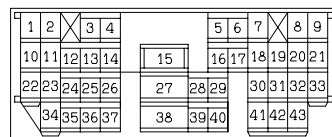
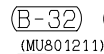
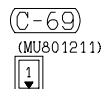
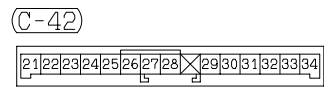
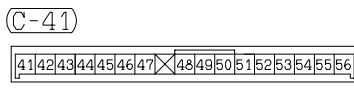
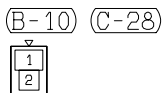
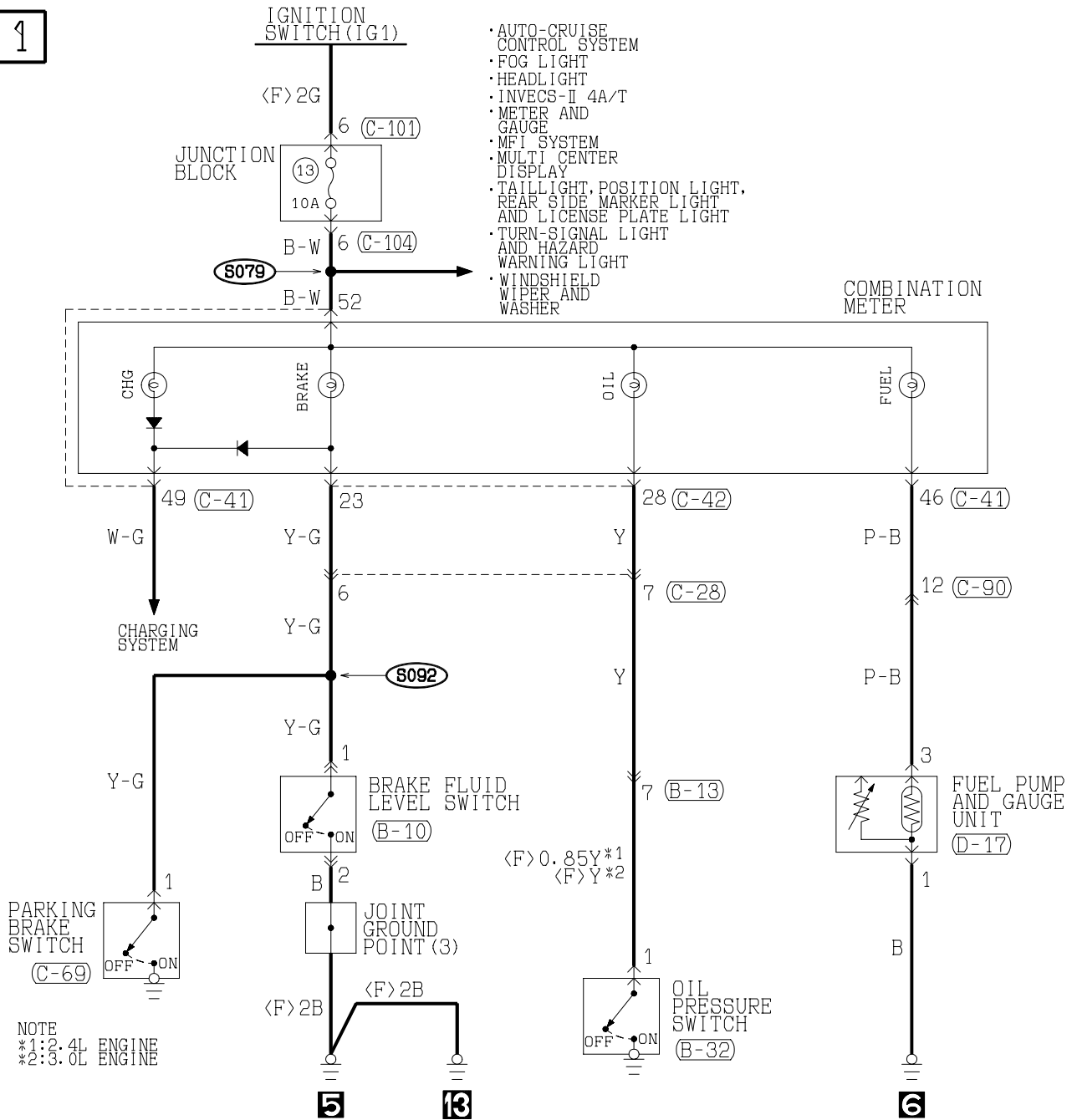

WIRE COLOR CODE  
B: BLACK LG: LIGHT GREEN G: GREEN L: BLUE  
BR: BROWN O: ORANGE GR: GRAY R: RED  
W: WHITE SB: SKY BLUE P: PINK Y: YELLOW  
V: VIOLET

H1S10M05AA

TSB Revision

TSB Revision

# POWER WINDOWS <ECLIPSE>

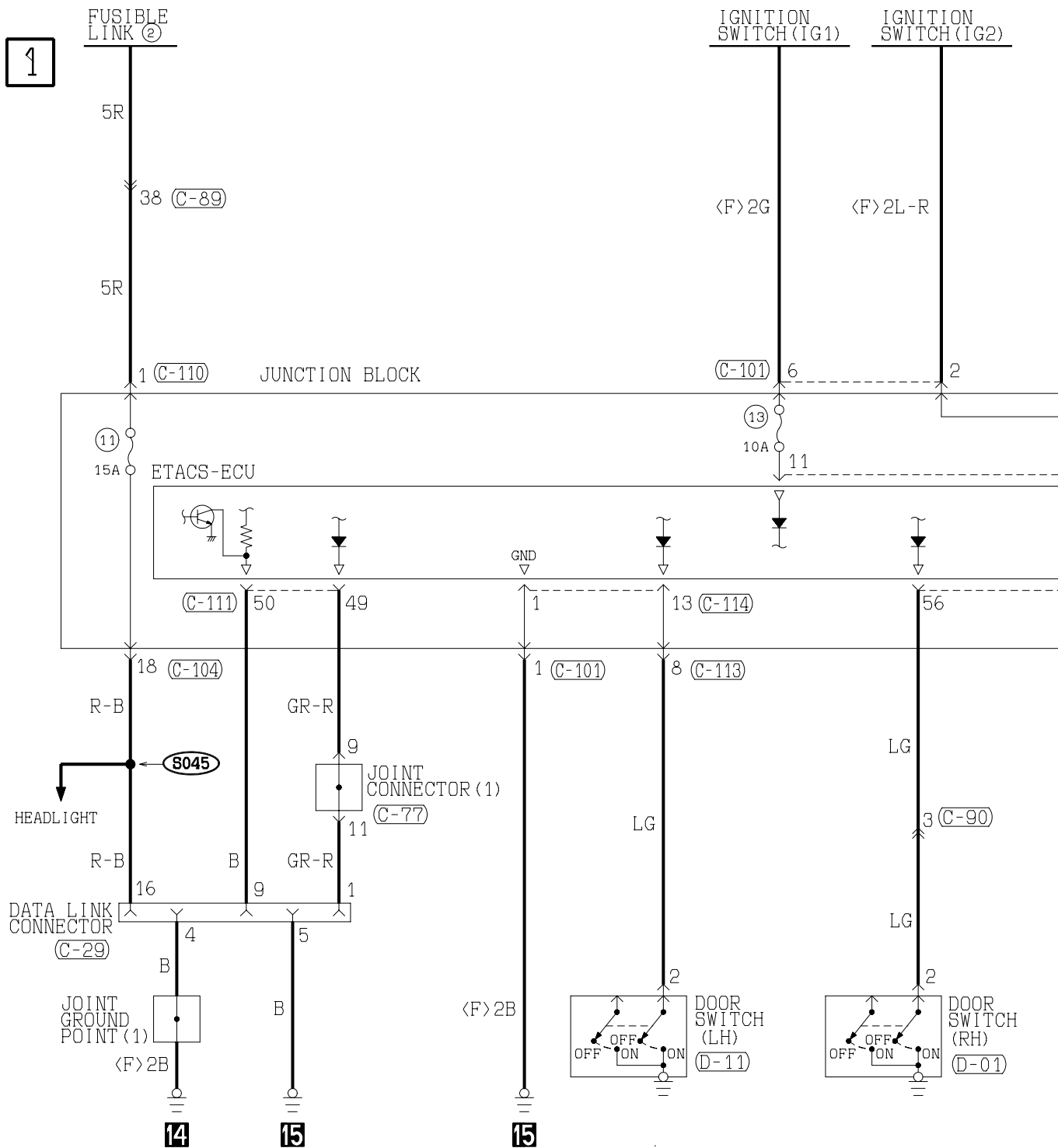

(A-04X)



(A-09X)

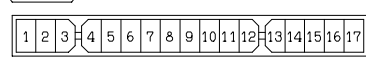

(C-29) FRONT SIDE

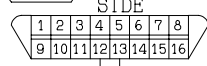

(C-77)

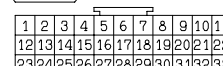

(C-78)

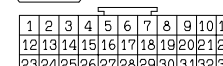

(C-111) (MU801584)

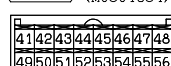

(C-113)

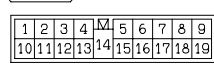

(C-114)

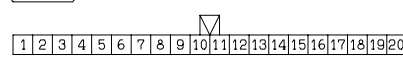

(D-01)



(D-11)



TSB Revision

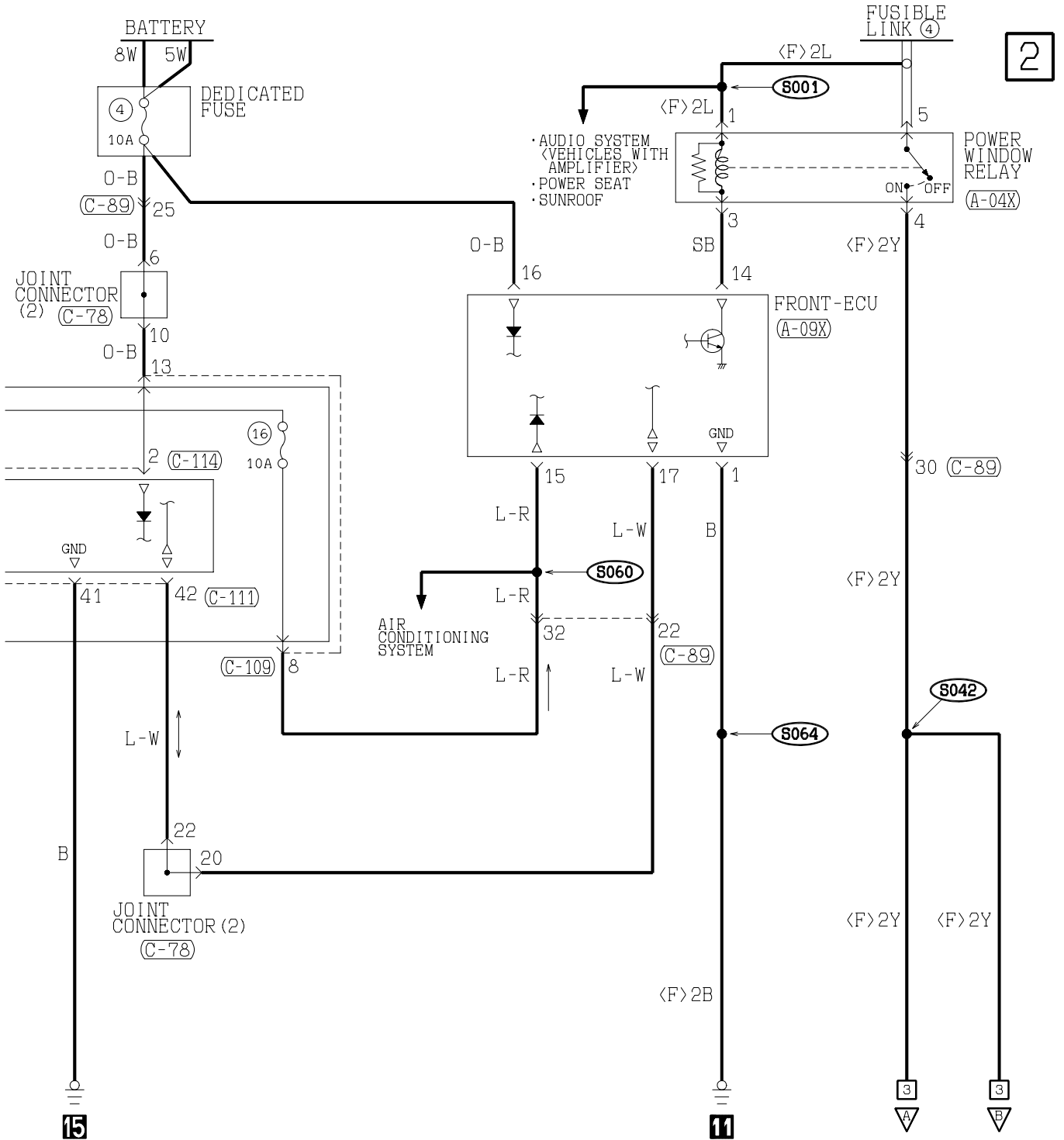

(C-89)

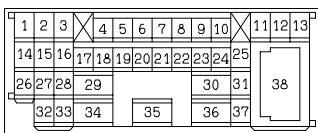

(C-90)

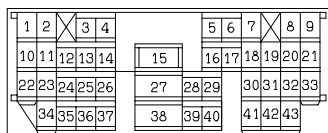

(C-101)



(C-104)

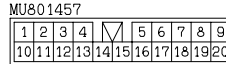

(C-109)

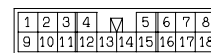

(C-110)



POWER WINDOWS <ECLIPSE> (CONTINUED)

3

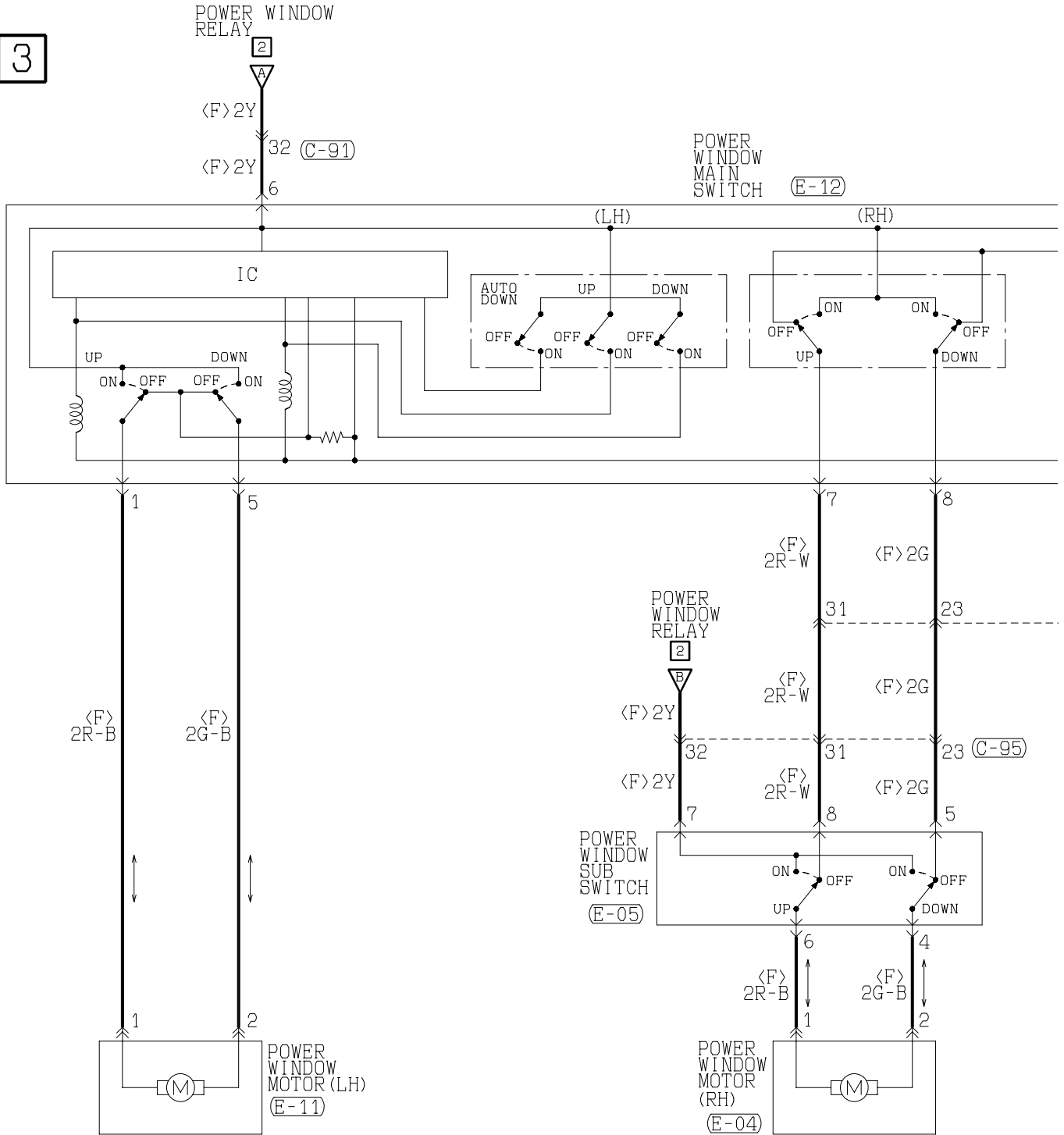

(C-91)

1	2	3	4	5	6	7	8	9
10	11	12	13	14	15	16	17	18
19	20	21	22	23	24	25	26	27
28	29	30	31	32				

(C-95)

1	2	3	4	5	6	7	8	9
10	11	12	13	14	15	16	17	18
19	20	21	22	23	24	25	26	27
28	29	30	31	32				

(E-04)



(E-05)

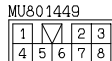

(E-11)



(E-12)

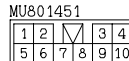



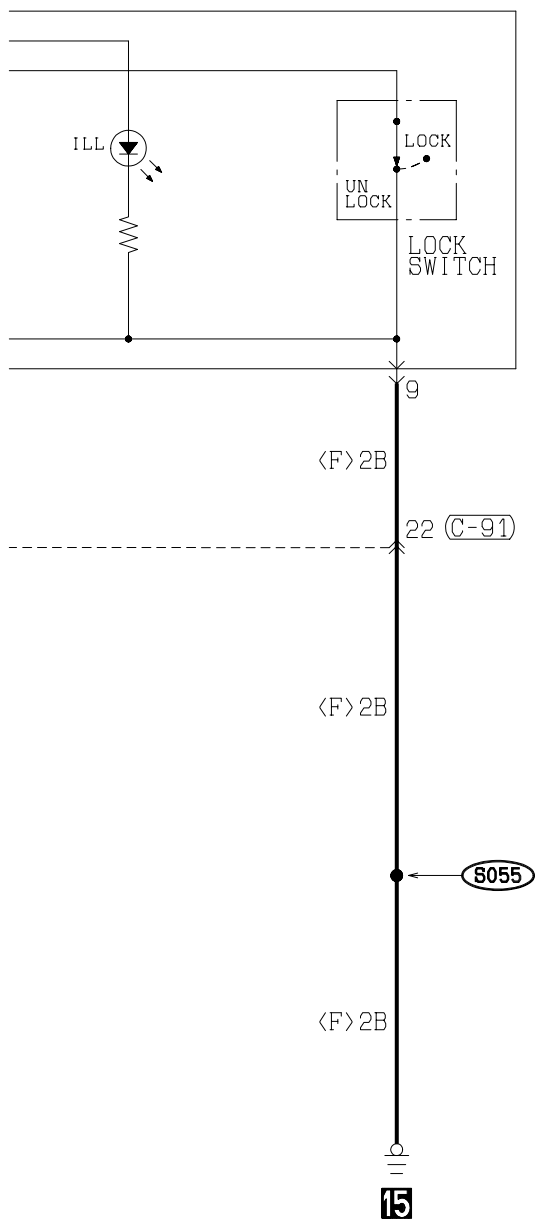

WIRE COLOR CODE  
 B : BLACK BR : BROWN G : GREEN GR : GRAY L : BLUE LG : LIGHT GREEN O : ORANGE  
 P : PINK R : RED SB : SKY BLUE V : VIOLET W : WHITE Y : YELLOW

H1S11M04BB

TSB Revision

# POWER WINDOWS <ECLIPSE SPYDER>

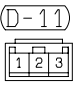
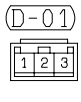
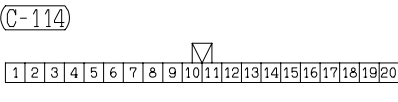
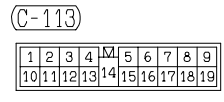
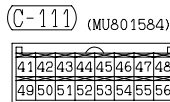
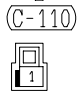
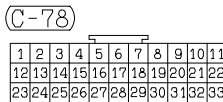
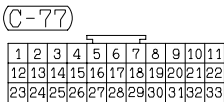
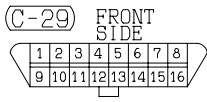
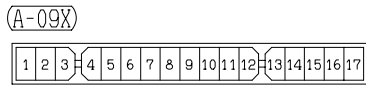
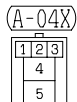
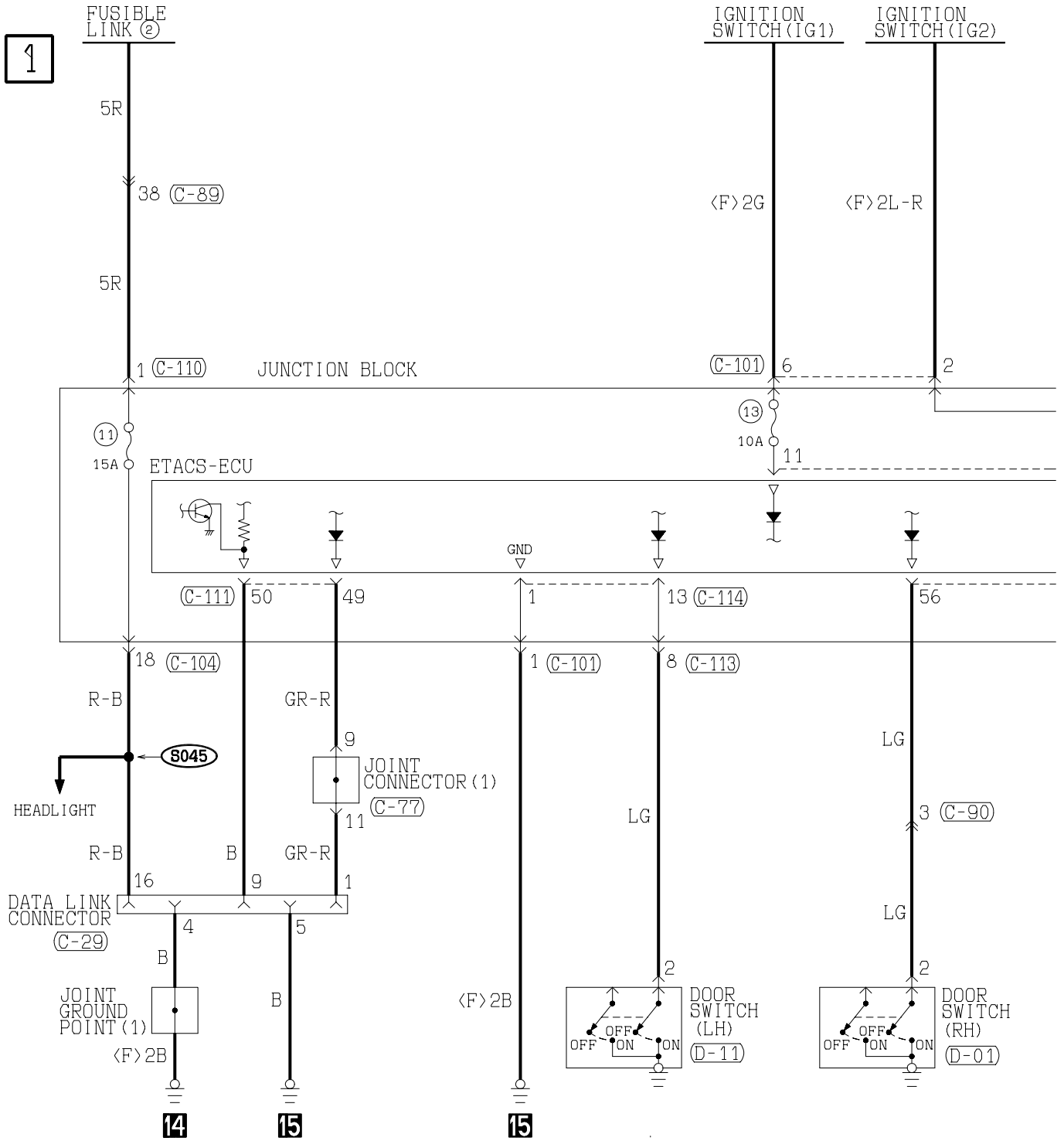

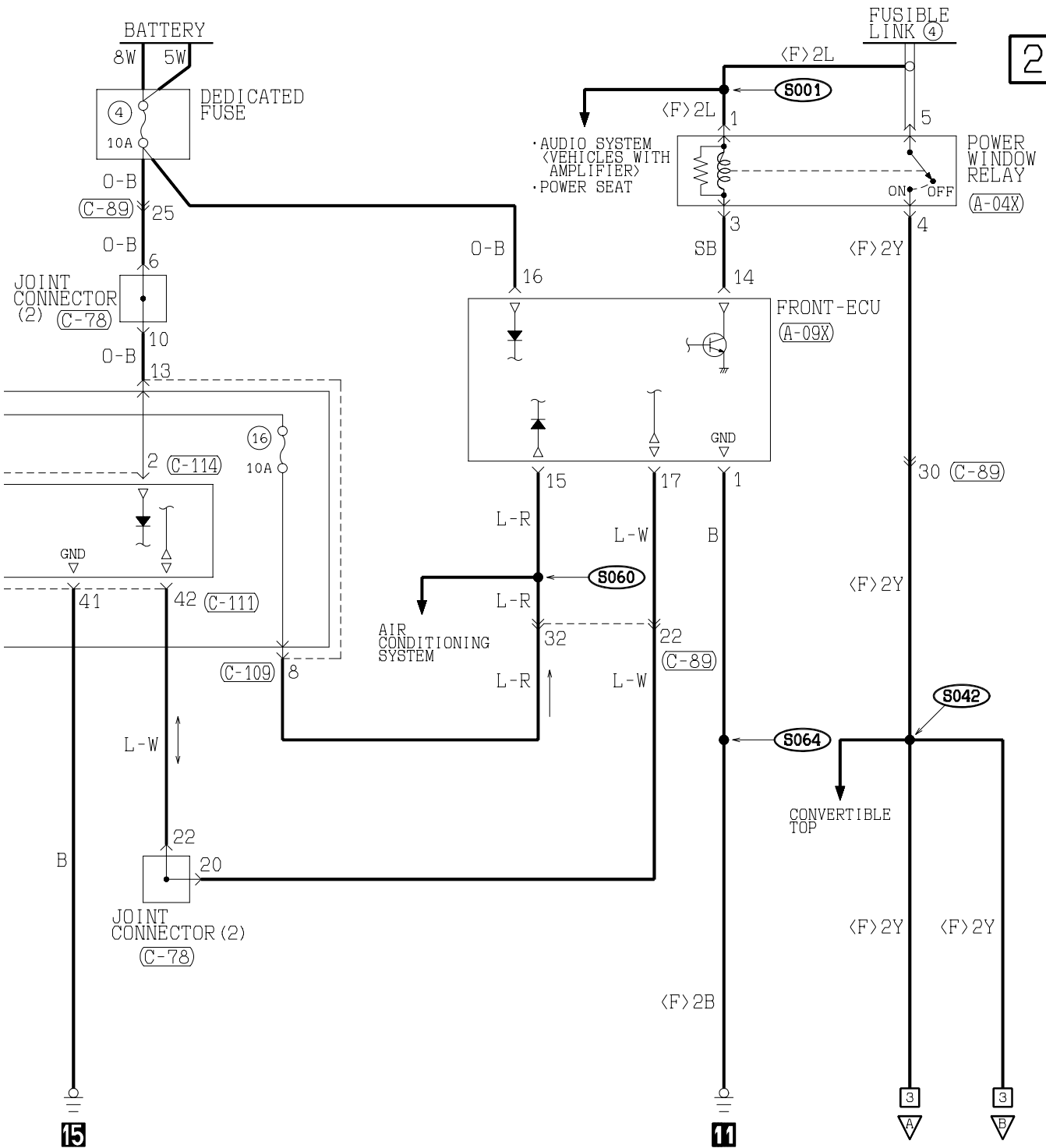

(C-89)

1	2	3	4	5	6	7	8	9	10	11	12	13
14	15	16	17	18	19	20	21	22	23	24	25	38
26	27	28	29			30	31					
32	33	34		35		36	37					

(C-90)

1	2	3	4		5	6	7	8	9		
10	11	12	13	14	15	16	17	18	19	20	21
22	23	24	25	26	27	28	29	30	31	32	33
34	35	36	37		38	39	40	41	42	43	

(C-101)  
MU801331

1	2		
3	4	5	6

(C-104)  
MU801457

1	2	3	4	5	6	7	8	9		
10	11	12	13	14	15	16	17	18	19	20

(C-109)

1	2	3	4	5	6	7	8		
9	10	11	12	13	14	15	16	17	18

POWER WINDOWS <ECLIPSE SPYDER> (CONTINUED)

3

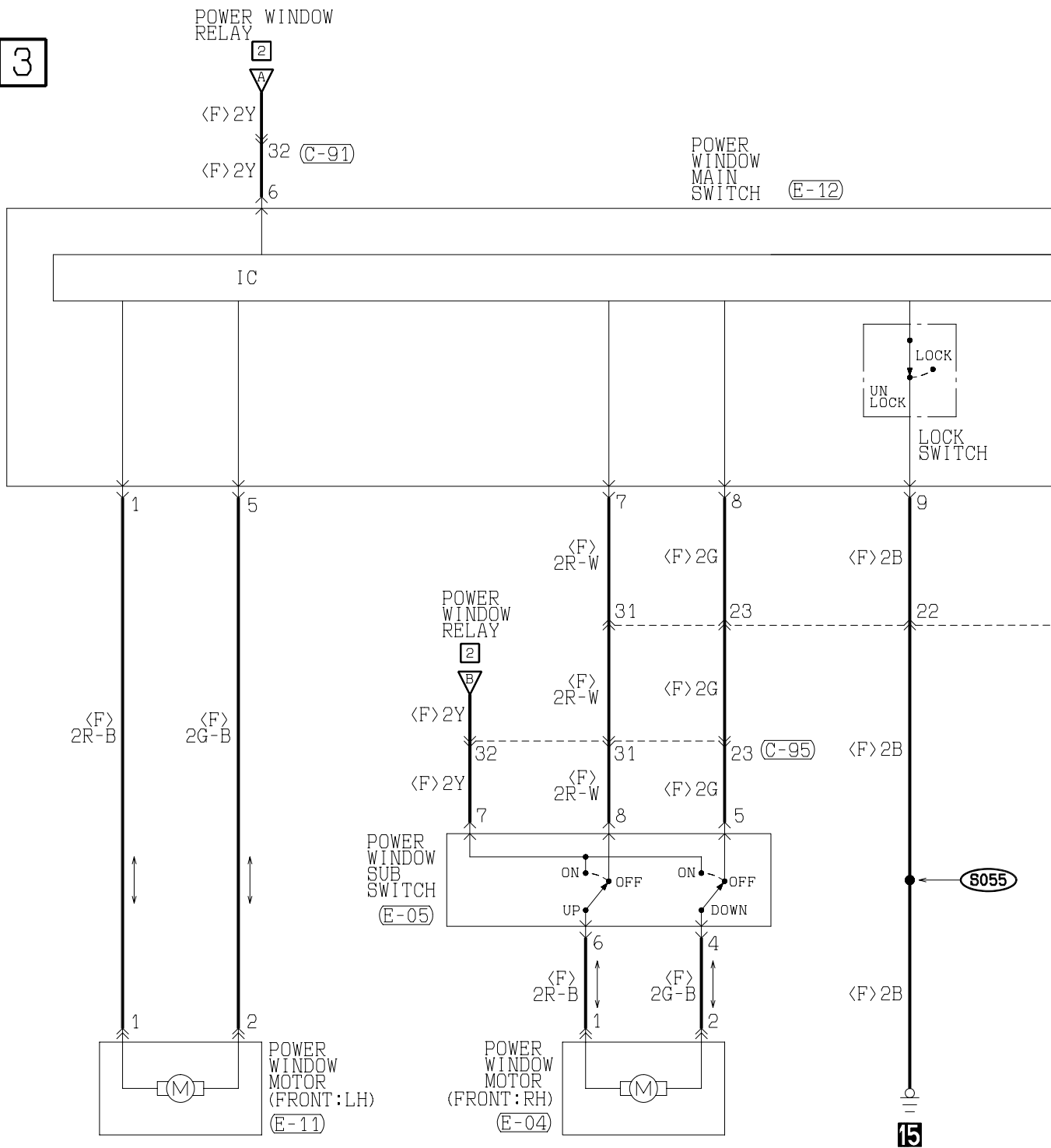

(C-90)

1	2	3	4	5	6	7	8	9
10	11	12	13	14	15	16	17	18
19	20	21	22	23	24	25	26	27
28	29	30	31	32	33	34	35	36
37	38	39	40	41	42	43		

(C-91)

1	2	3	4	5	6	7	8	9
10	11	12	13	14	15	16	17	18
19	20	21	22	23	24	25	26	27
28	29	30	31	32				

(C-95)

1	2	3	4	5	6	7	8	9
10	11	12	13	14	15	16	17	18
19	20	21	22	23	24	25	26	27
28	29	30	31	32				

(E-04)

1
2

(E-05)

MU801449

1	2	3
4	5	6
7	8	

(E-11)

1
2

TSB Revision

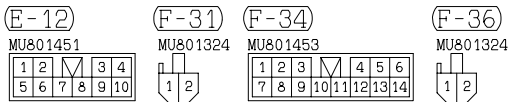
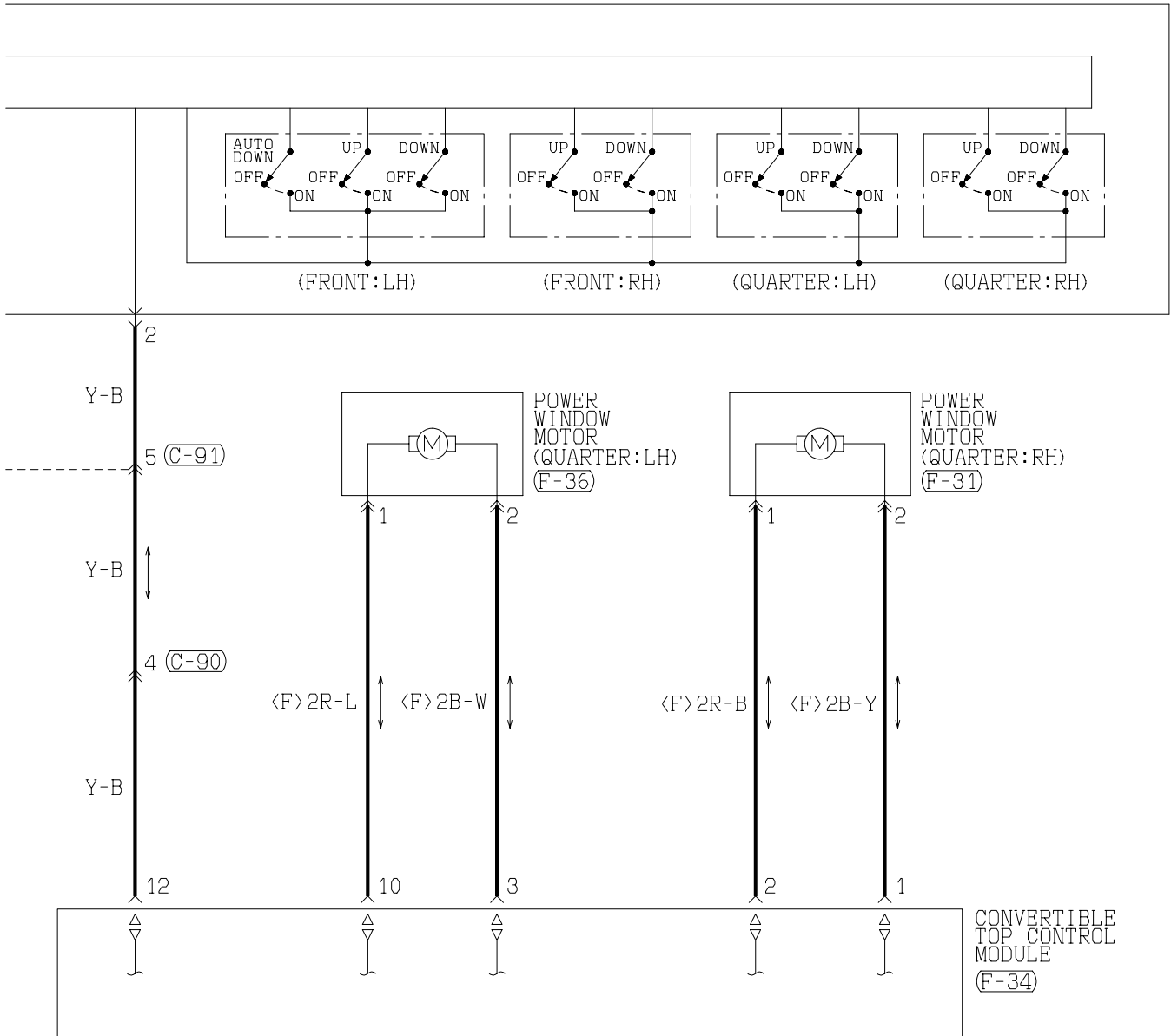

WIRE COLOR CODE  
 B : BLACK BR : BROWN G : GREEN GR : GRAY L : BLUE LG : LIGHT GREEN O : ORANGE  
 P : PINK R : RED SB : SKY BLUE V : VIOLET W : WHITE Y : YELLOW

H1S11M05BB

# CENTRAL DOOR LOCKING SYSTEM <VEHICLES WITHOUT KEYLESS ENTRY SYSTEM>

M1901004700139

1

JUNCTION BLOCK

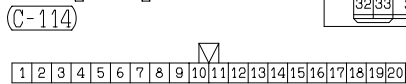
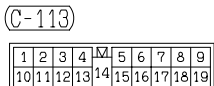
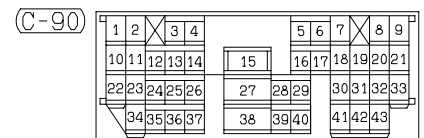
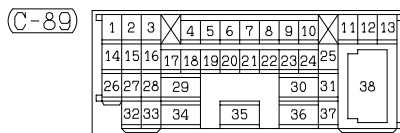
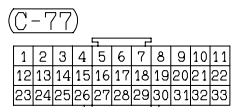
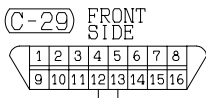
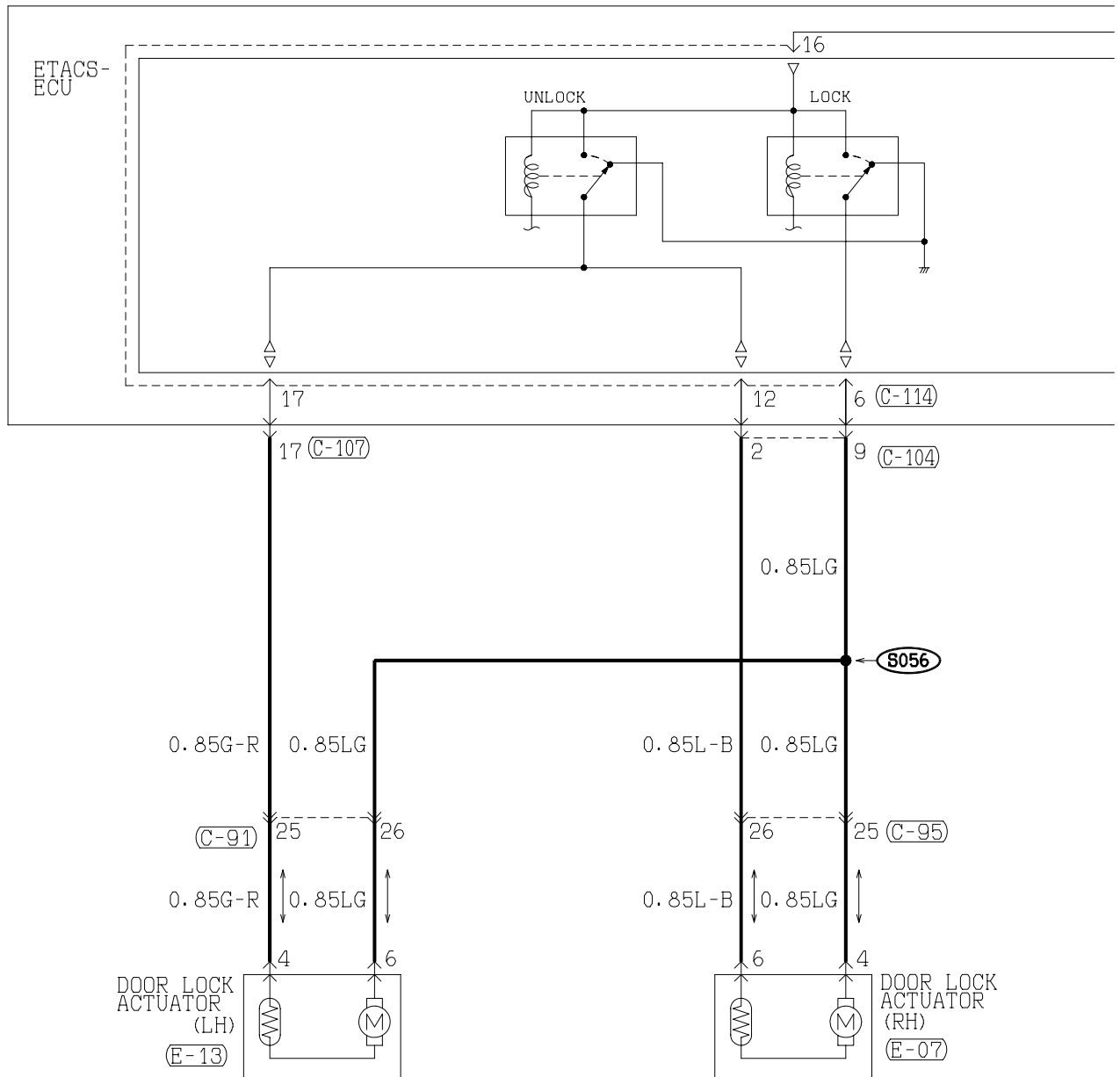

H1S11M06AA

TSB Revision

2

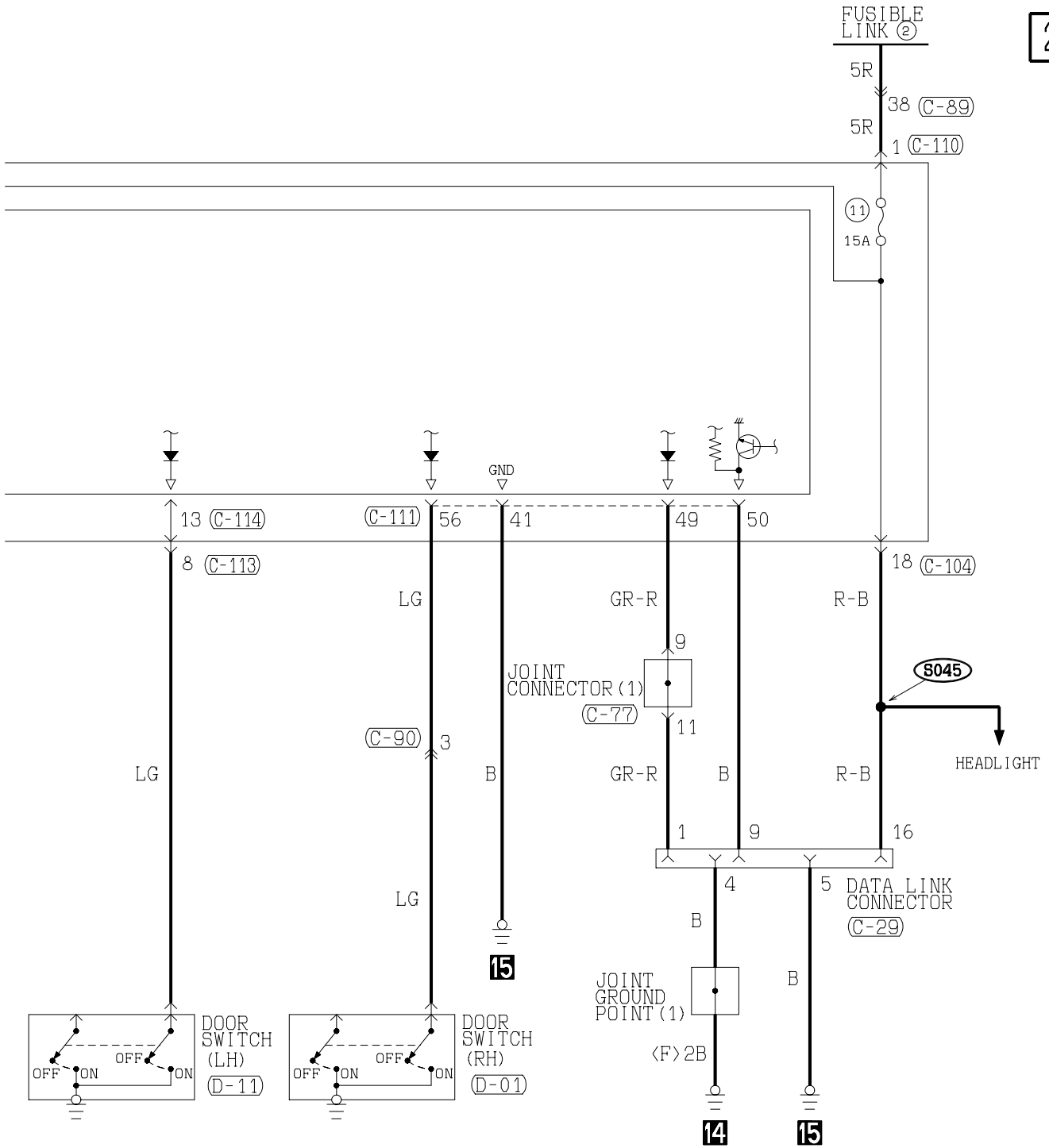

(C-91)

1	2	3	4	5	6	7	8	9
10	11	12	13	14	15	16	17	18
19	20	21	22	23	24	25	26	27
28	29	30	31	32				

(D-01)

1	2	3
---	---	---

(D-11)

1	2	3
---	---	---

(E-07)

1	2	3
---	---	---

MU802341

(C-95)

1	2	3	4	5	6	7	8	9
10	11	12	13	14	15	16	17	18
19	20	21	22	23	24	25	26	27
28	29	30	31	32				

(E-13)

1	2	3
4	5	6

MU802341

1	2	3
4	5	6

(C-104)

MU801457

1	2	3	4	5	6	7	8	9
10	11	12	13	14	15	16	17	18
19	20							

(C-107)

1	2	3	4	5	6	7	8	9	10
11	12	13	14	15	16	17	18	19	20
21	22								

WIRE COLOR CODE  
 B : BLACK    LG : LIGHT GREEN  
 BR : BROWN    O : ORANGE  
 W : WHITE    SB : SKY BLUE  
 V : VIOLET

(C-110)

1
---

(C-111)

1
---

(C-111) (MU801584)

41	42	43	44	45	46	47	48
49	50	51	52	53	54	55	56

L : BLUE  
 R : RED  
 Y : YELLOW

H1S11M06AB

TSB Revision

CENTRAL DOOR LOCKING SYSTEM <VEHICLES WITHOUT KEYLESS ENTRY SYSTEM> (CONTINUED)

3

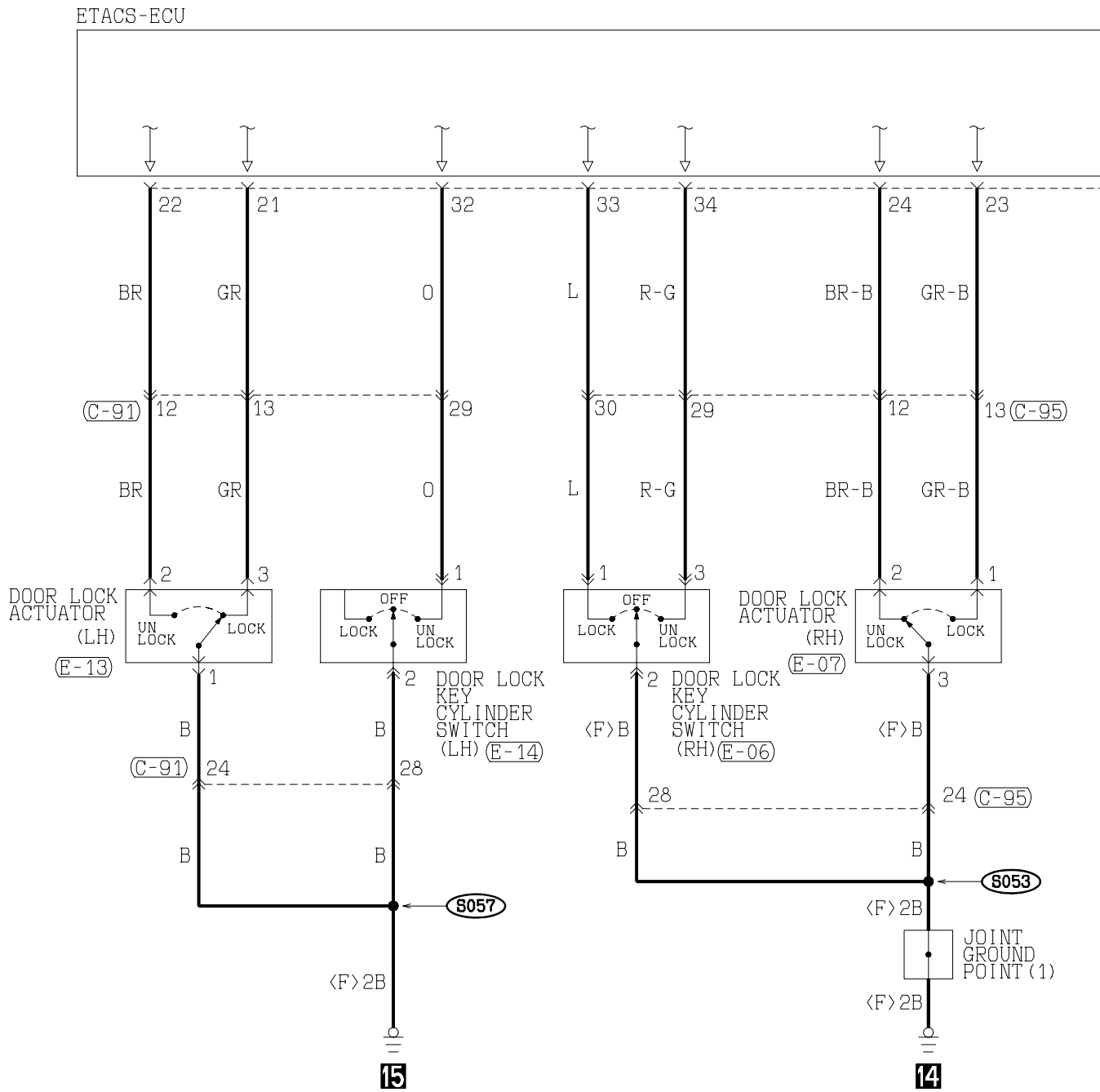

(C-88) MU801547

1	2	3	4	5	6	7
8	9	10	11	12	13	14
15	16	17	18	19	20	21
22	23	24	25	26	27	28
29	30	31	32	33	34	35

(C-91)

1	2	3	4	5	6	7	8	9
10	11	12	13	14	15	16	17	18
19	20	21	22	23	24	25	26	27
28	29	30	31	32	33	34	35	36

(C-95)

1	2	3	4	5	6	7	8	9
10	11	12	13	14	15	16	17	18
19	20	21	22	23	24	25	26	27
28	29	30	31	32	33	34	35	36

(C-111) (MU801584)

41	42	43	44	45	46	47	48
49	50	51	52	53	54	55	56

(C-112) (MU801585)

21	22	23	24	25	26	27	28	29	30
31	32	33	34	35	36	37	38	39	40

(E-05) MU801449

1	2	3
4	5	6
7	8	9

(E-06) MU802338

1	2	3
---	---	---



4

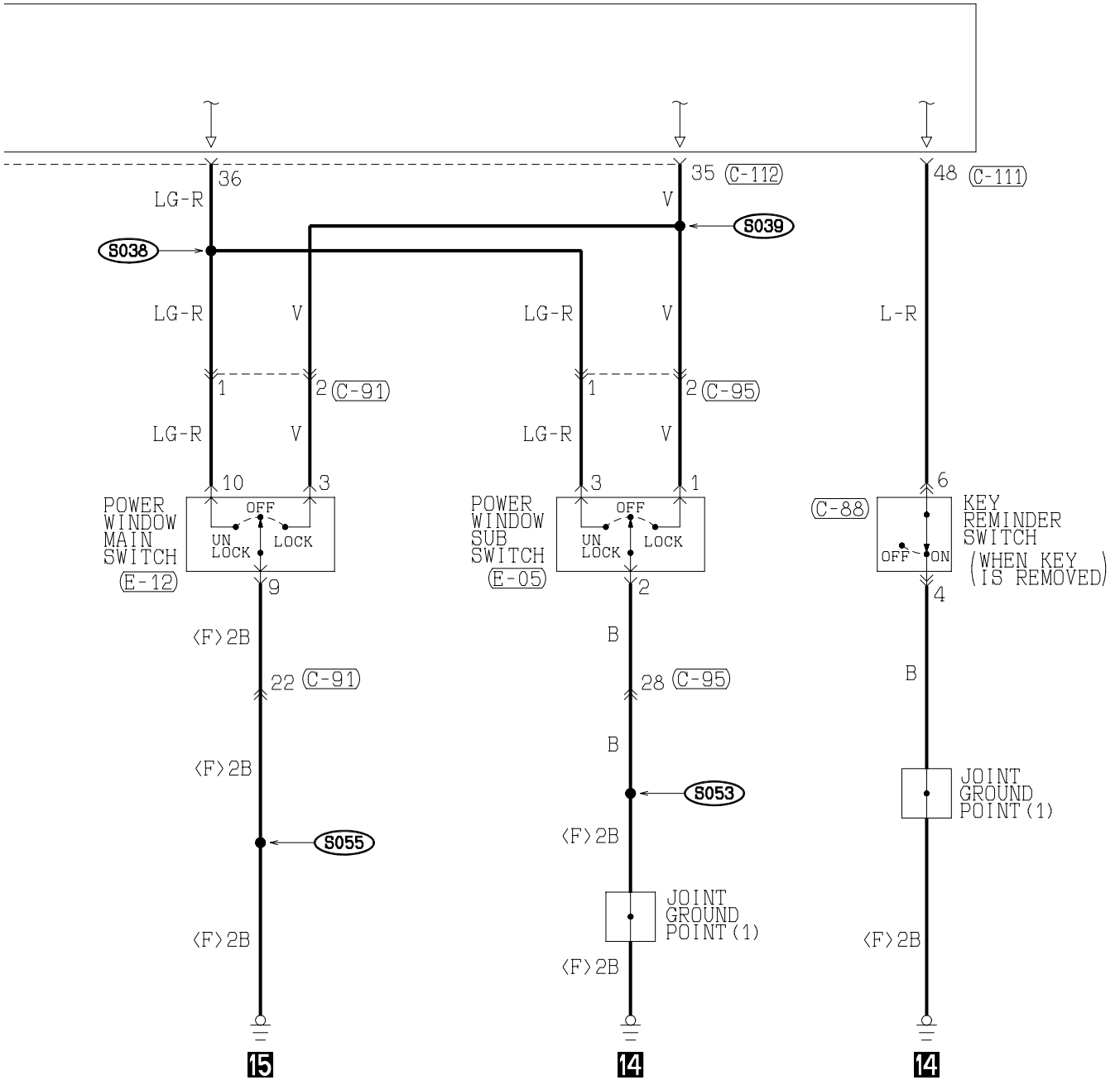

E-07  
 MU802341



E-12  
 MU801451

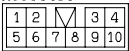

E-13  
 MU802341



E-14  
 MU802338



WIRE COLOR CODE  
 B : BLACK BR : BROWN G : GREEN GR : GRAY L : BLUE LG : LIGHT GREEN O : ORANGE  
 P : PINK R : RED SB : SKY BLUE V : VIOLET W : WHITE Y : YELLOW

H1S11M06BB

TSB Revision

# CENTRAL DOOR LOCKING SYSTEM <VEHICLES WITH KEYLESS ENTRY SYSTEM (WITHOUT THEFT-ALARM SYSTEM) >

M1901004700128

1

JUNCTION BLOCK

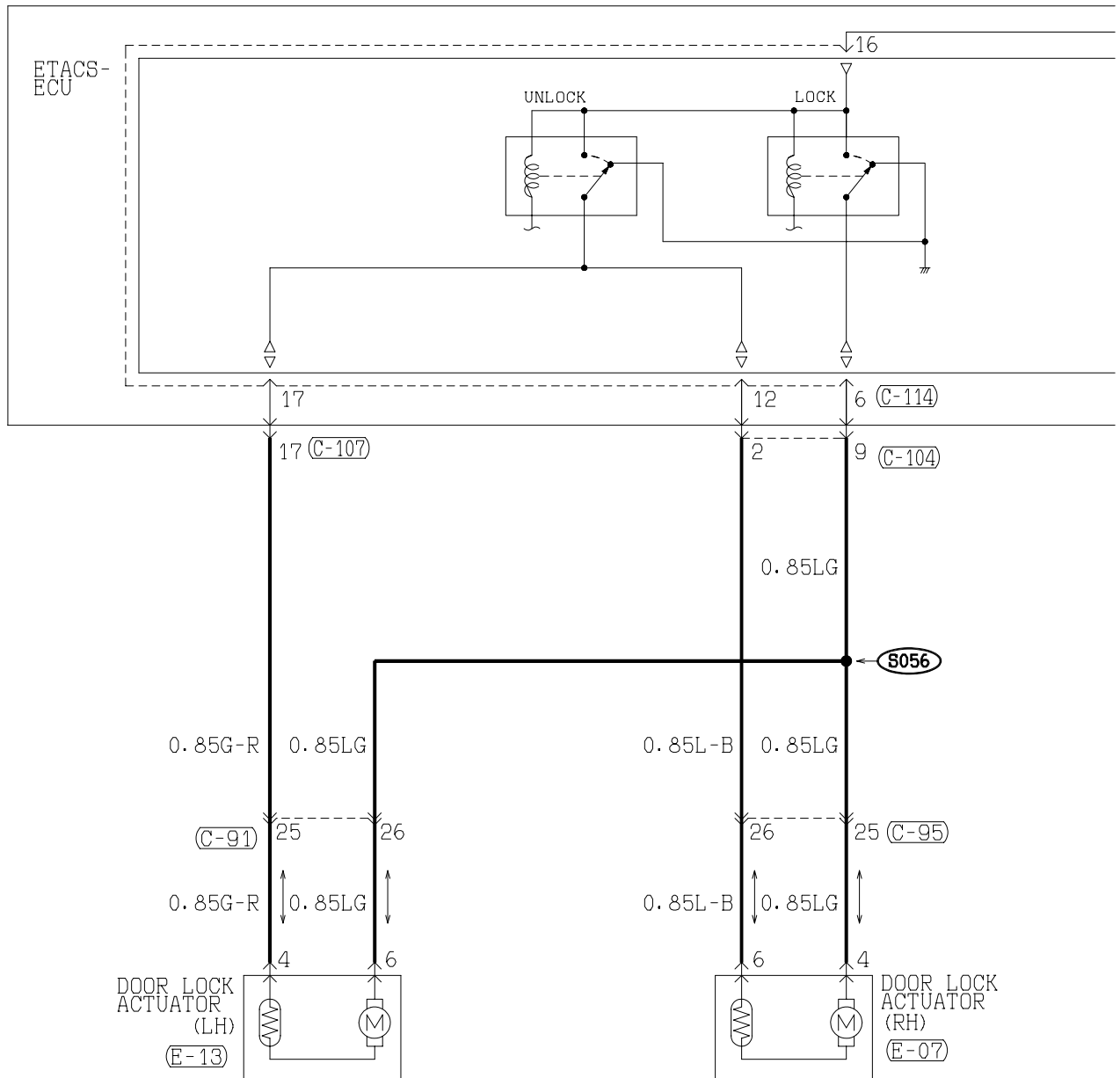

(A-11X)

(A-25)

(C-89)

(C-91)

(C-95)

(C-104)

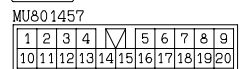
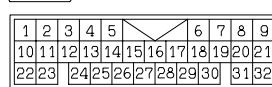
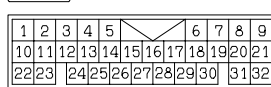
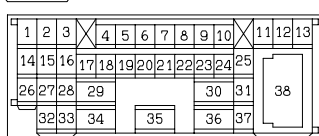

H1S11M07AA

TSB Revision

2

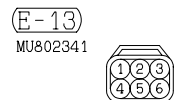
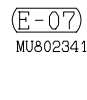
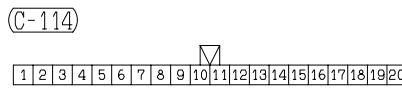
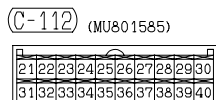
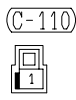
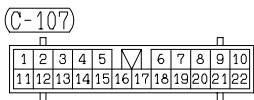
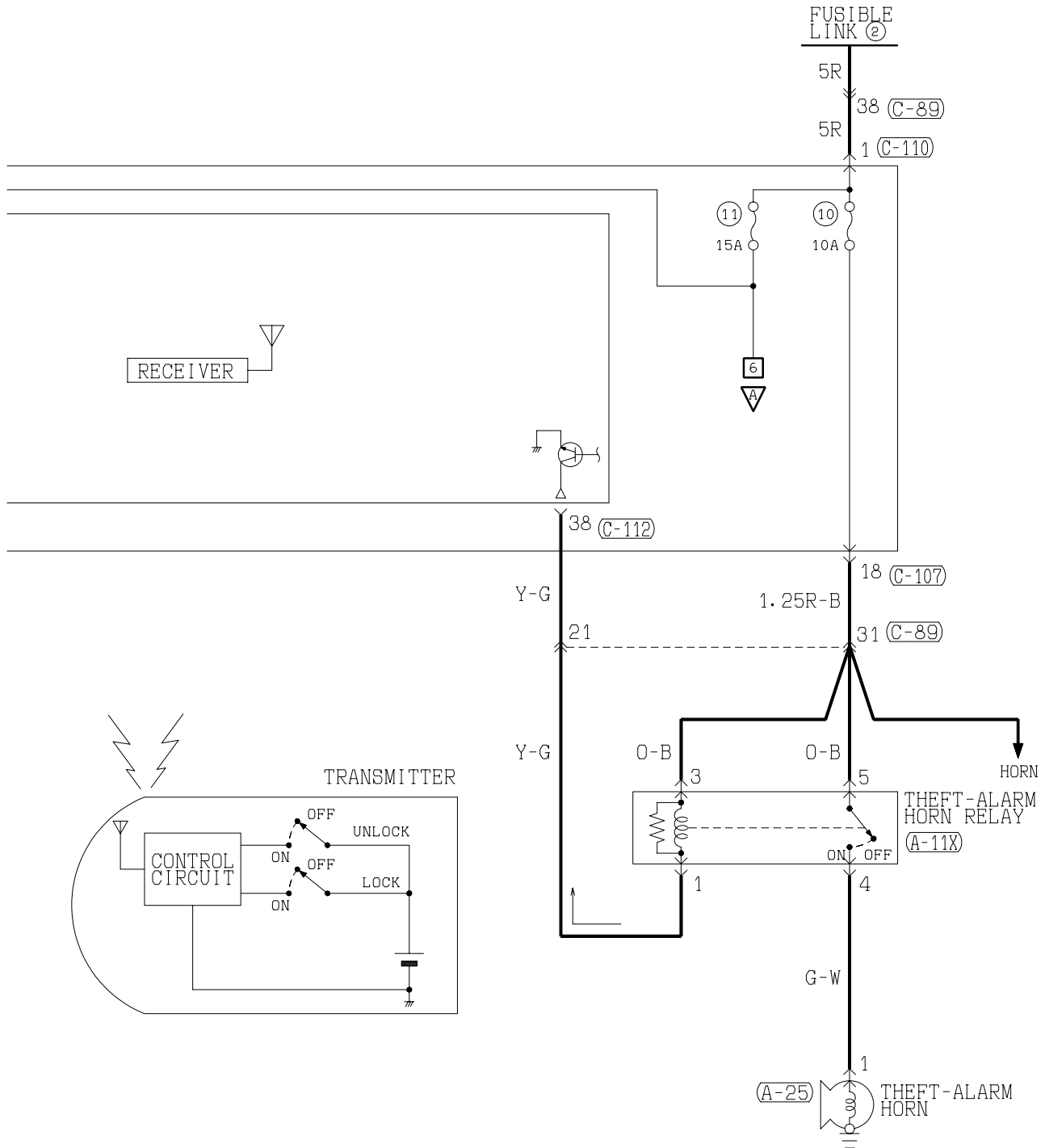

WIRE COLOR CODE  
 B : BLACK BR: BROWN G : GREEN GR: GRAY L : BLUE LG: LIGHT GREEN O : ORANGE  
 P : PINK R : RED SB: SKY BLUE V : VIOLET W : WHITE Y : YELLOW

H1S11M07AB

TSB Revision



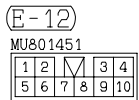
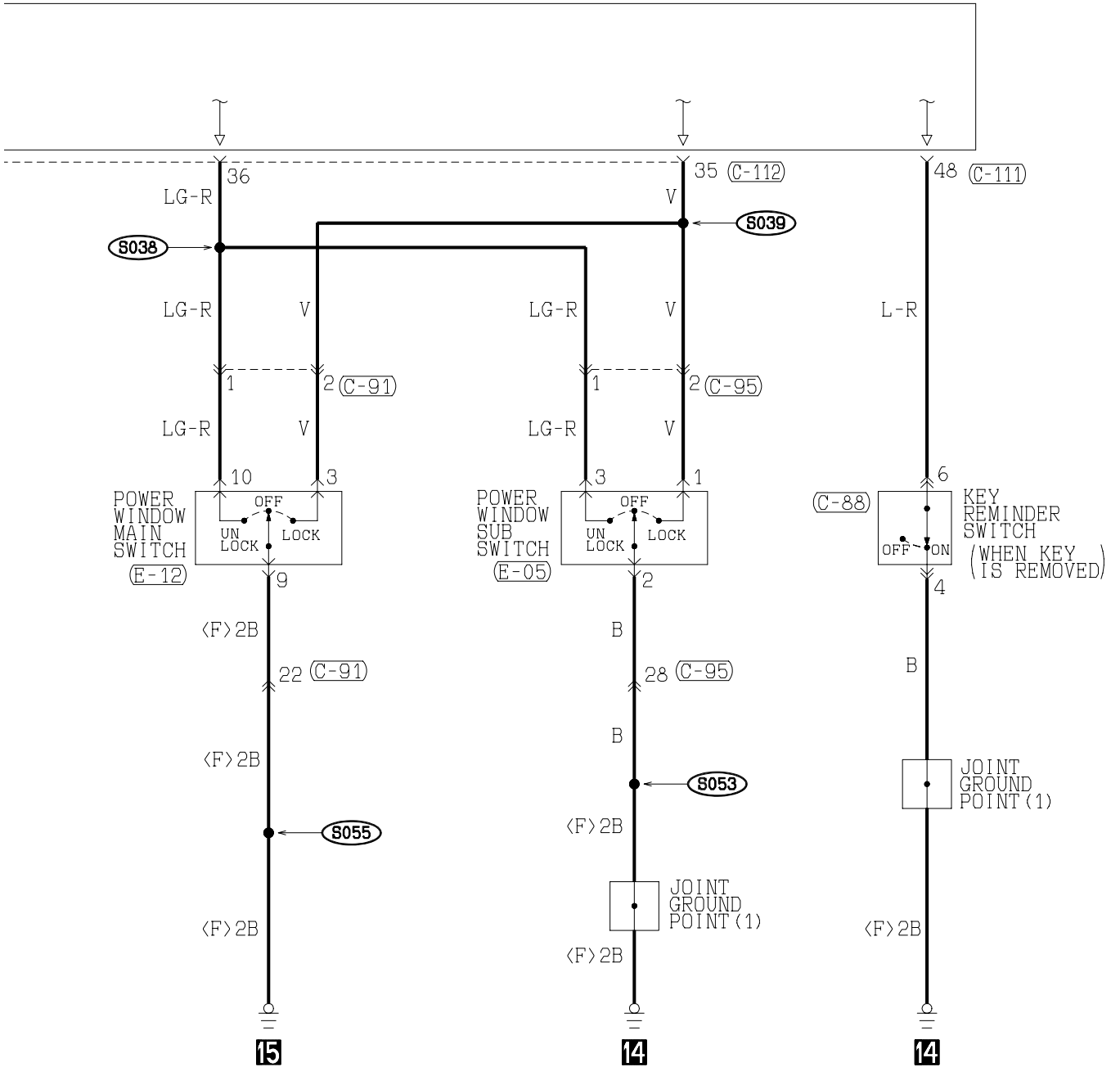

WIRE COLOR CODE  
 B : BLACK BR : BROWN G : GREEN GR : GRAY L : BLUE LG : LIGHT GREEN O : ORANGE  
 P : PINK R : RED SB : SKY BLUE V : VIOLET W : WHITE Y : YELLOW

H1S11M07BB

TSB Revision

CENTRAL DOOR LOCKING SYSTEM <VEHICLES WITH KEYLESS ENTRY SYSTEM (WITHOUT THEFT-ALARM SYSTEM) > (CONTINUED)

5

JUNCTION BLOCK

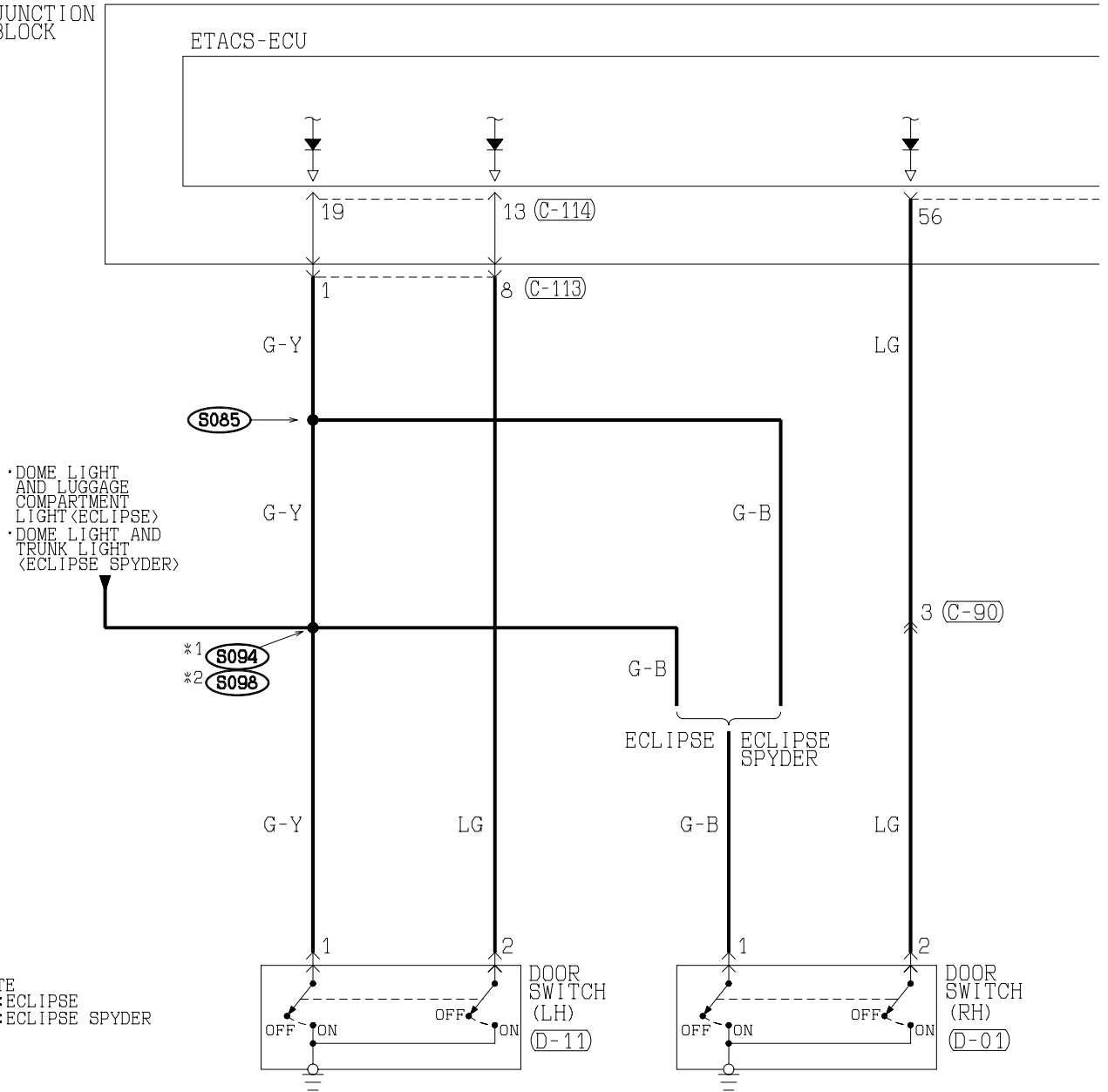

• DOME LIGHT AND LUGGAGE COMPARTMENT LIGHT (ECLIPSE)  
• DOME LIGHT AND TRUNK LIGHT (ECLIPSE SPYDER)

NOTE  
\*1: ECLIPSE  
\*2: ECLIPSE SPYDER

(C-29) FRONT SIDE

1	2	3	4	5	6	7	8
9	10	11	12	13	14	15	16

(C-77)

1	2	3	4	5	6	7	8	9	10	11
12	13	14	15	16	17	18	19	20	21	22
23	24	25	26	27	28	29	30	31	32	33

(C-90)

1	2	3	4	5	6	7	8	9
10	11	12	13	14	15	16	17	18
19	20	21	22	23	24	25	26	27
28	29	30	31	32	33	34	35	36
37	38	39	40	41	42	43		

(C-104) MU801457

1	2	3	4	5	6	7	8	9
10	11	12	13	14	15	16	17	18
19	20	21	22	23	24	25	26	27
28	29	30	31	32	33	34	35	36
37	38	39	40	41	42	43		

(C-111) (MU801584)

1	2	3	4	5	6	7	8	9
10	11	12	13	14	15	16	17	18
19	20	21	22	23	24	25	26	27
28	29	30	31	32	33	34	35	36
37	38	39	40	41	42	43	44	45
46	47	48	49	50	51	52	53	54
55	56							

TSB Revision

6

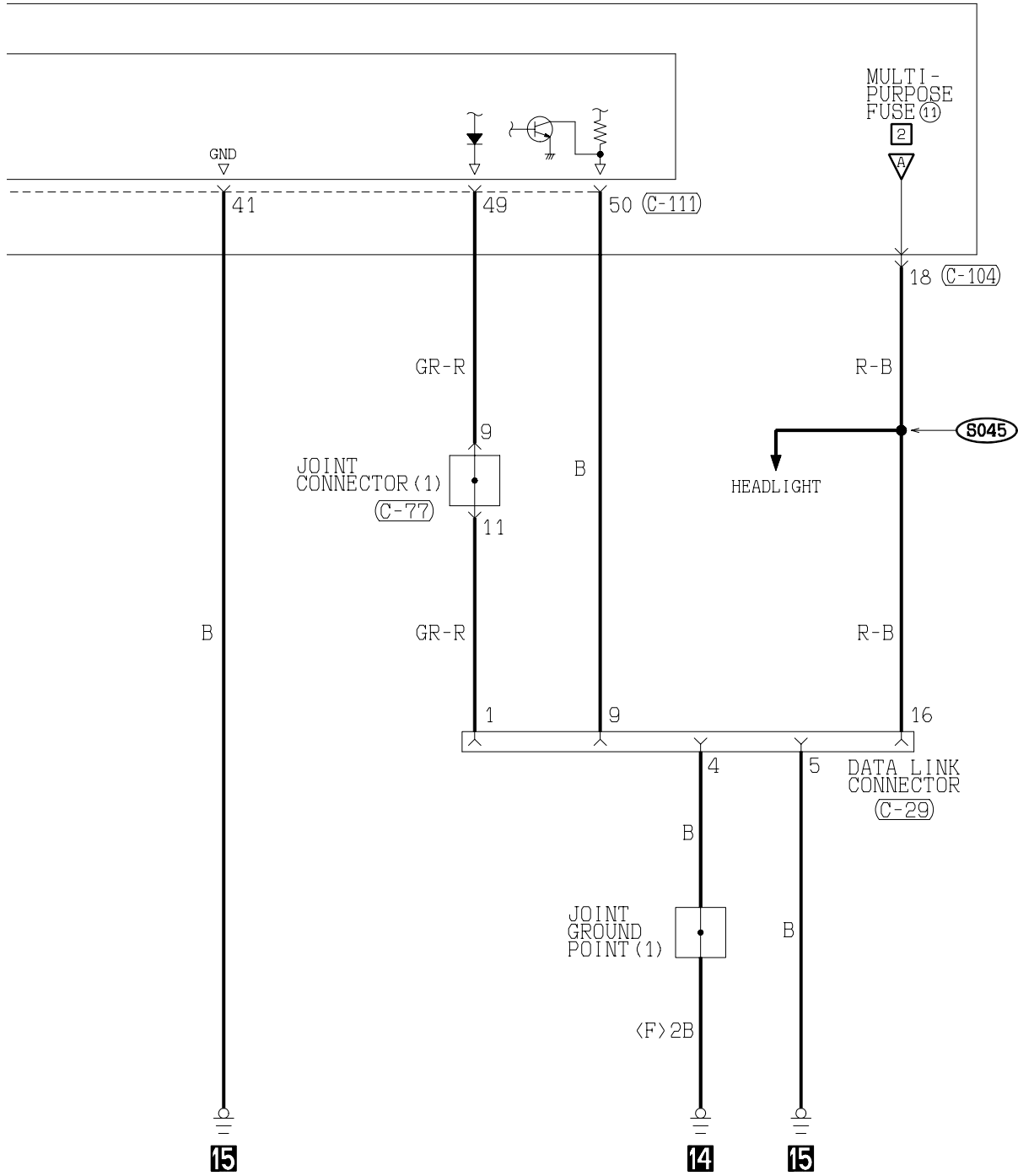

(C-113)

(C-114)

(D-01)

(D-11)

1	2	3	4	5	6	7	8	9	
10	11	12	13	14	15	16	17	18	19

1	2	3	4	5	6	7	8	9	10	11	12	13	14	15	16	17	18	19	20
---	---	---	---	---	---	---	---	---	----	----	----	----	----	----	----	----	----	----	----

1	2	3
---	---	---

1	2	3
---	---	---

WIRE COLOR CODE  
 B : BLACK BR : BROWN G : GREEN GR : GRAY L : BLUE LG : LIGHT GREEN O : ORANGE  
 P : PINK R : RED SB : SKY BLUE V : VIOLET W : WHITE Y : YELLOW

H1S11M07CB

TSB Revision

CENTRAL DOOR LOCKING SYSTEM <VEHICLES WITH KEYLESS ENTRY SYSTEM (WITHOUT THEFT-ALARM SYSTEM) > (CONTINUED)

7

NOTE  
 \*1: VEHICLES WITH SUNROOF OR ECLIPSE SPYDER  
 \*2: VEHICLES WITHOUT SUNROOF  
 \*3: ECLIPSE  
 \*4: ECLIPSE SPYDER

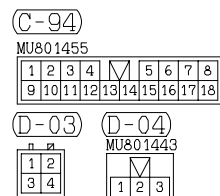
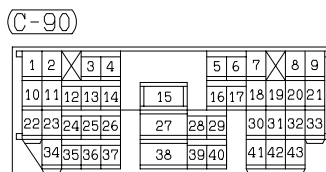
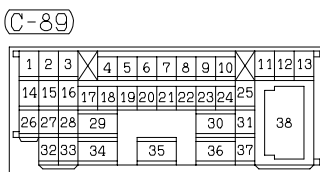
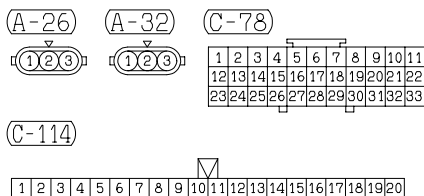
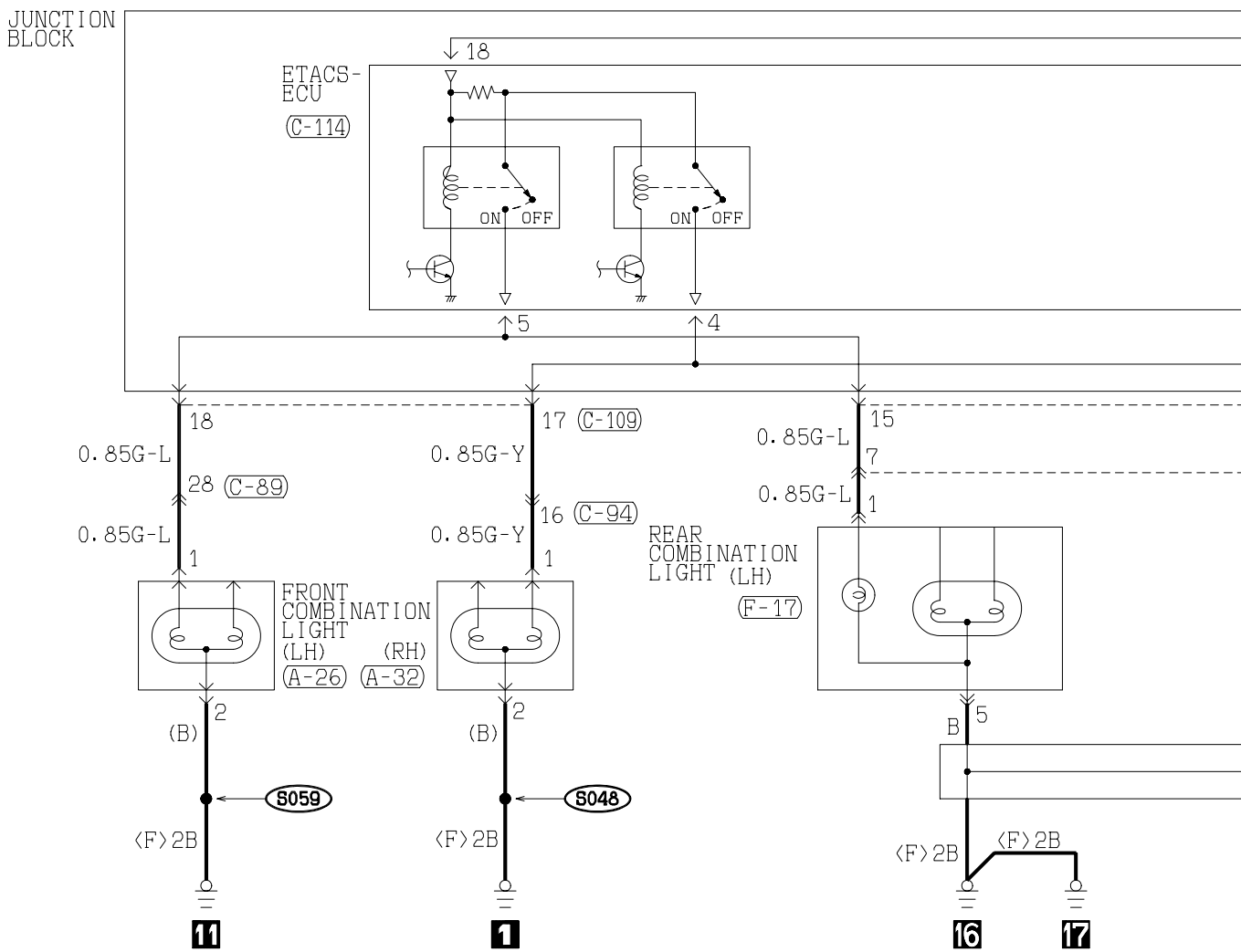

H1S11M07DA





# CENTRAL DOOR LOCKING SYSTEM <VEHICLES WITH KEYLESS ENTRY SYSTEM (WITH THEFT-ALARM SYSTEM) >

M1901004700117

1

JUNCTION BLOCK

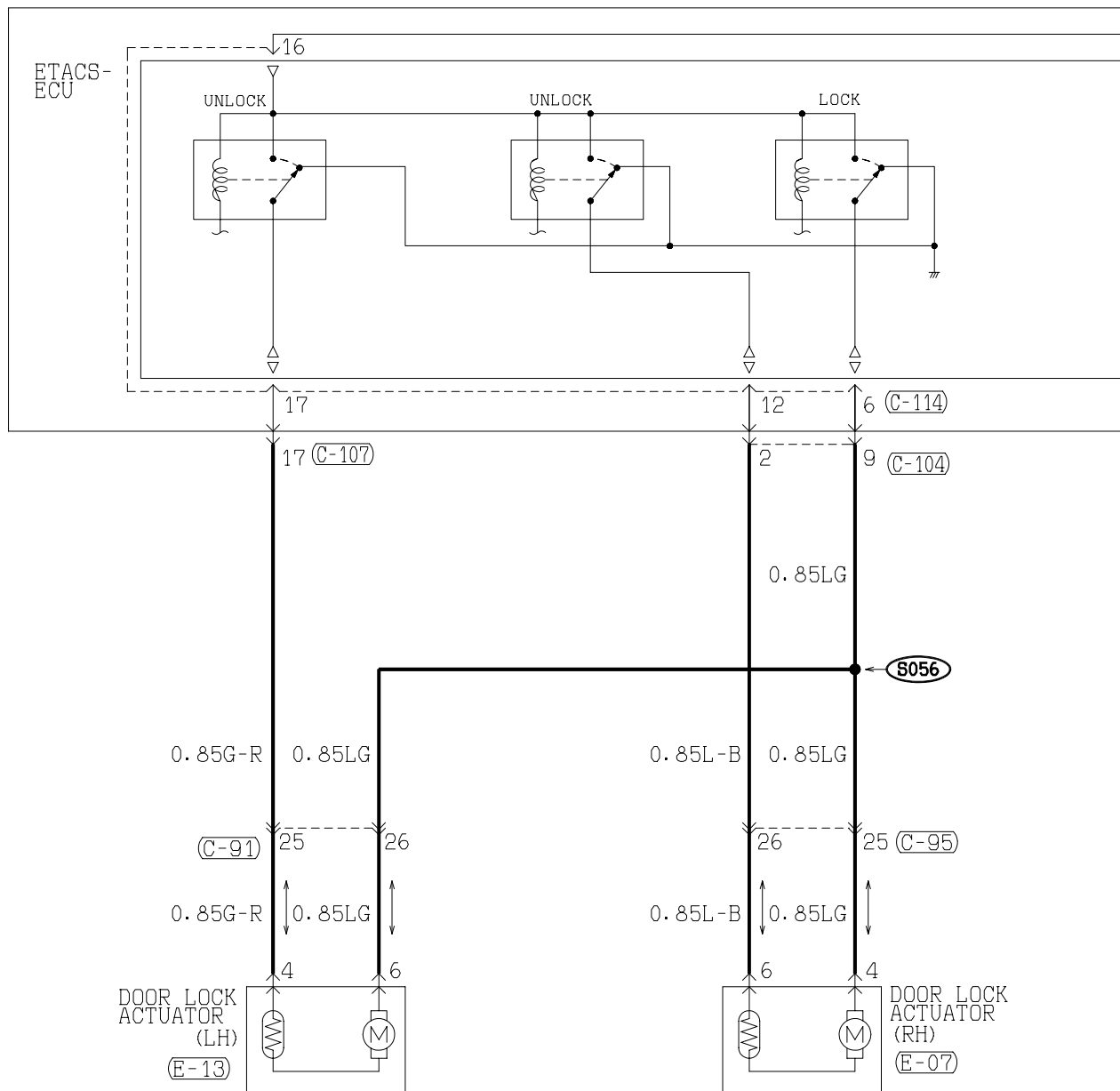

(A-11X)

1	2	3
4		
5		

(A-25)

1
---

(C-89)

1	2	3	4	5	6	7	8	9	10	11	12	13
14	15	16	17	18	19	20	21	22	23	24	25	38
26	27	28	29					30	31			
32	33	34	35	36	37							

(C-91)

1	2	3	4	5	6	7	8	9
10	11	12	13	14	15	16	17	18
19	20	21	22	23	24	25	26	27
28	29	30	31	32				

(C-95)

1	2	3	4	5	6	7	8	9
10	11	12	13	14	15	16	17	18
19	20	21	22	23	24	25	26	27
28	29	30	31	32				

(C-104)

MU801457

1	2	3	4	5	6	7	8	9
10	11	12	13	14	15	16	17	18
19	20							

H1S11M08AA

TSB Revision

2

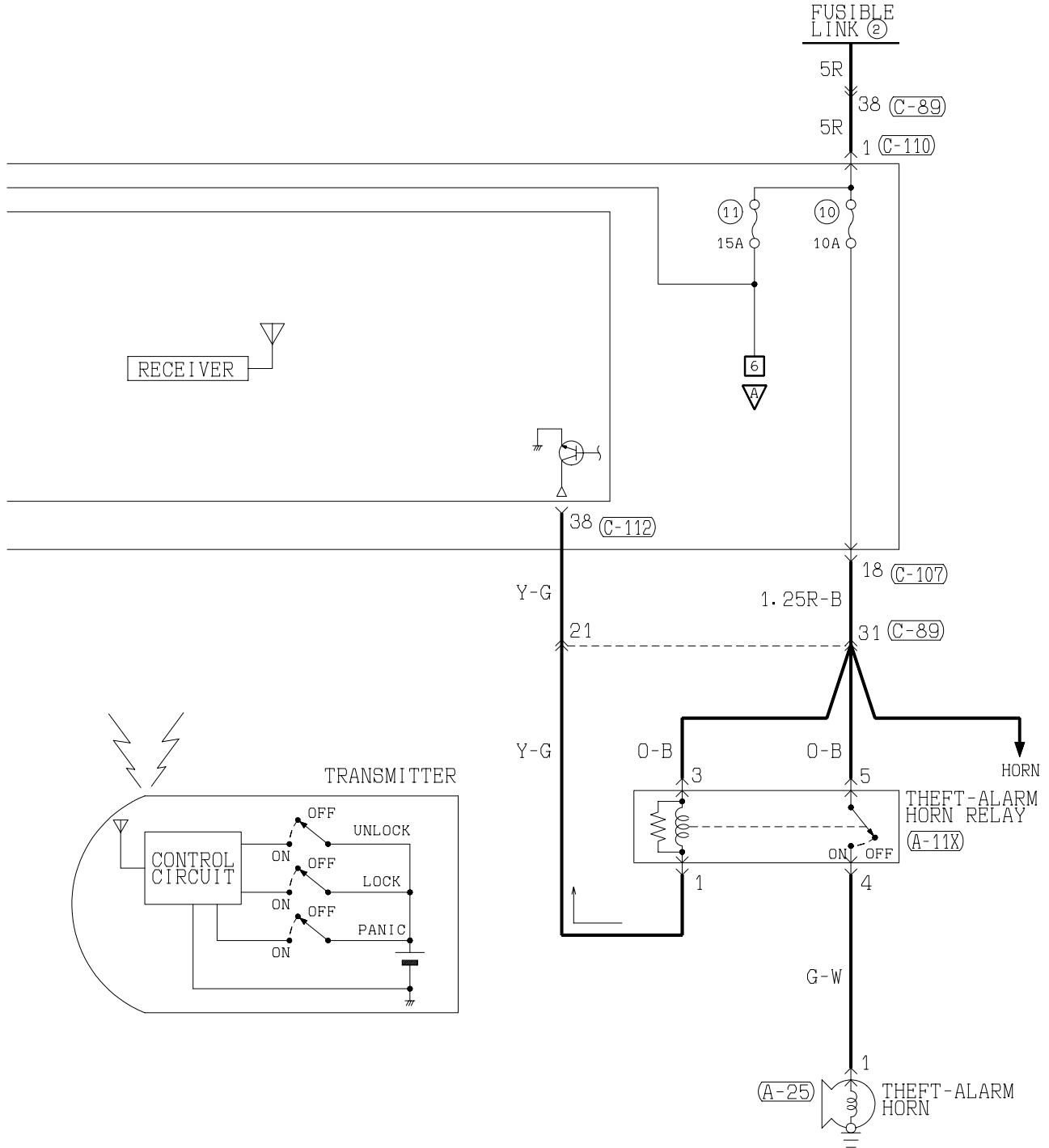

C-107

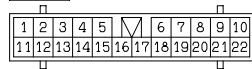

C-110



C-112 (MU801585)

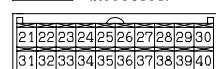

C-114

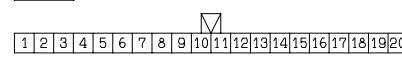

E-07



E-13



WIRE COLOR CODE

B : BLACK  
P : PINK

BR : BROWN  
R : RED

G : GREEN  
SB : SKY BLUE

GR : GRAY  
V : VIOLET

L : BLUE  
W : WHITE

LG : LIGHT GREEN  
Y : YELLOW

O : ORANGE

TSB Revision

CENTRAL DOOR LOCKING SYSTEM <VEHICLES WITH KEYLESS ENTRY SYSTEM (WITH THEFT-ALARM SYSTEM) > (CONTINUED)

3

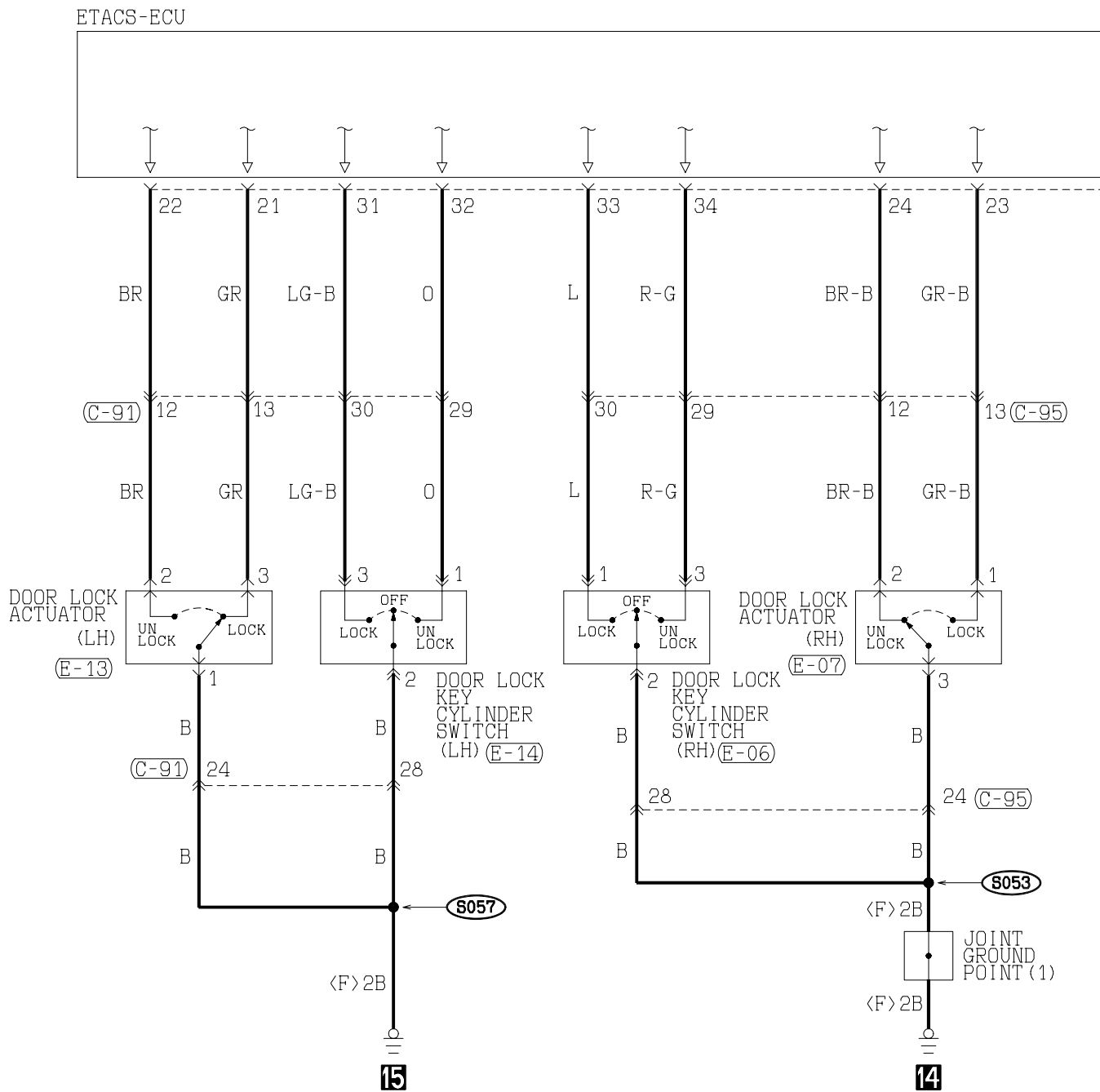

(C-88) MU801547

1	2	3	4	5	6	7
8	9	10	11	12	13	14
15	16	17	18	19	20	21
22	23	24	25	26	27	28
29	30	31	32	33	34	35

(C-91)

1	2	3	4	5	6	7	8	9
10	11	12	13	14	15	16	17	18
19	20	21	22	23	24	25	26	27
28	29	30	31	32	33	34	35	36

(C-95)

1	2	3	4	5	6	7	8	9
10	11	12	13	14	15	16	17	18
19	20	21	22	23	24	25	26	27
28	29	30	31	32	33	34	35	36

(C-111) (MU801584)

41	42	43	44	45	46	47	48
49	50	51	52	53	54	55	56

(C-112) (MU801585)

21	22	23	24	25	26	27	28	29	30
31	32	33	34	35	36	37	38	39	40

(E-05) MU801449

1	2	3
4	5	6
7	8	9

(E-06) MU802338

1	2	3
---	---	---

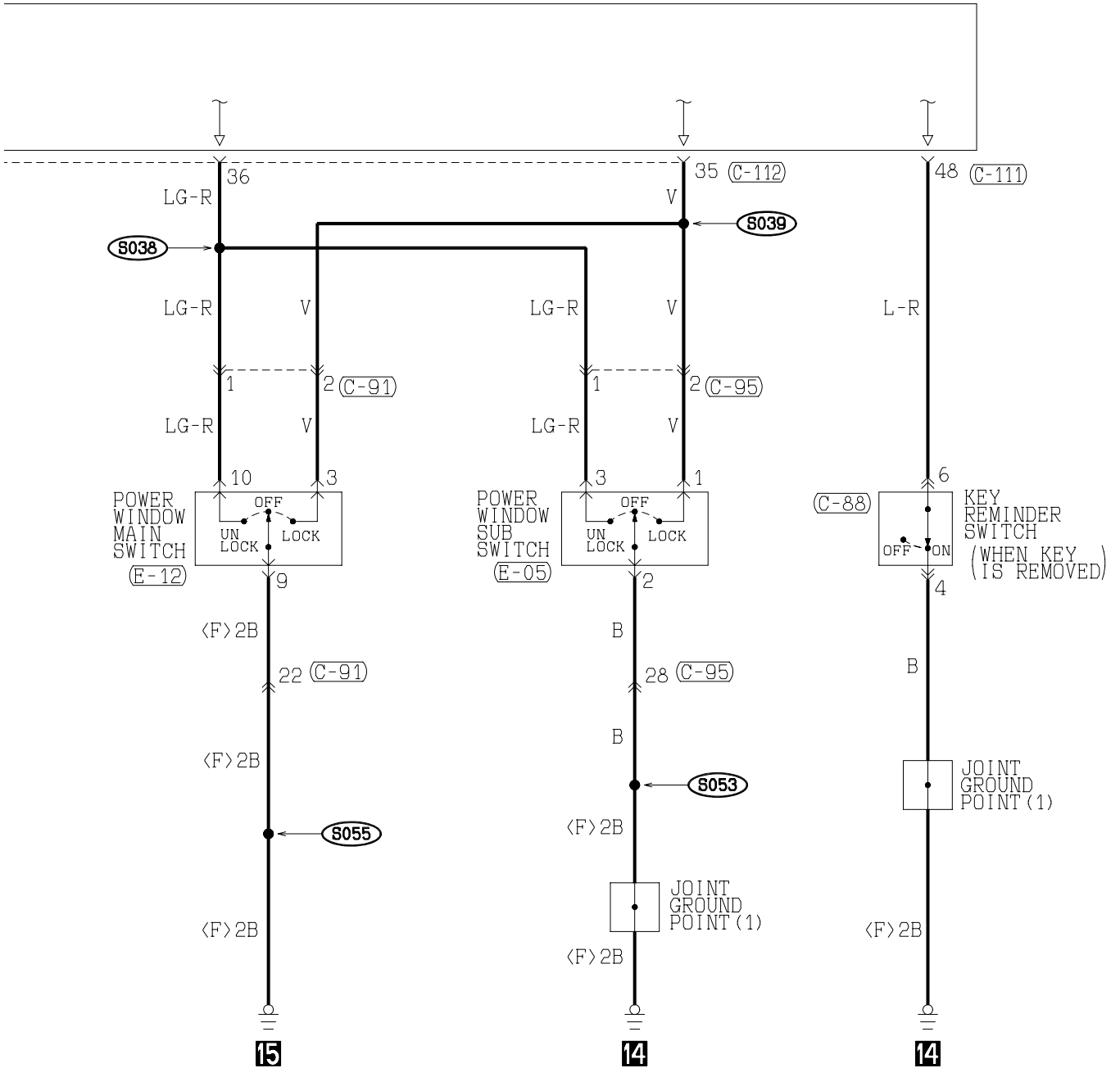

E-07  
MU802341



E-12  
MU801451

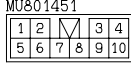

E-13  
MU802341



E-14  
MU802338



WIRE COLOR CODE  
 B : BLACK BR : BROWN G : GREEN GR : GRAY L : BLUE LG : LIGHT GREEN O : ORANGE  
 P : PINK R : RED SB : SKY BLUE V : VIOLET W : WHITE Y : YELLOW

H1S11M08BB

TSB Revision

CENTRAL DOOR LOCKING SYSTEM <VEHICLES WITH KEYLESS ENTRY SYSTEM (WITH THEFT-ALARM SYSTEM) > (CONTINUED)

5

JUNCTION BLOCK

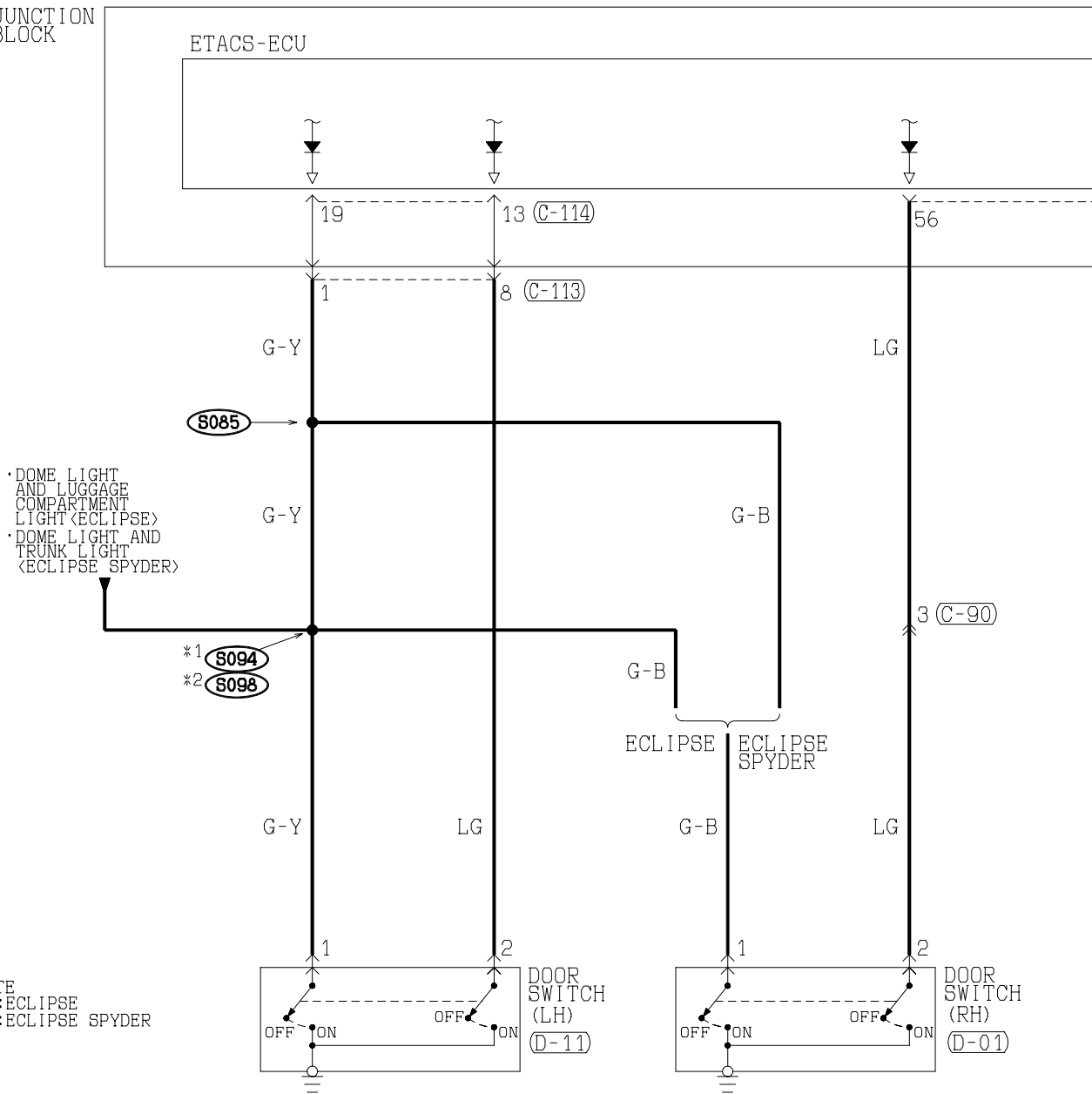

NOTE  
\*1: ECLIPSE  
\*2: ECLIPSE SPYDER

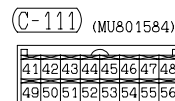
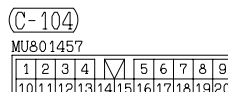
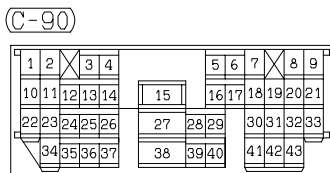
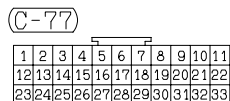
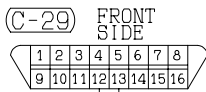

TSB Revision

6

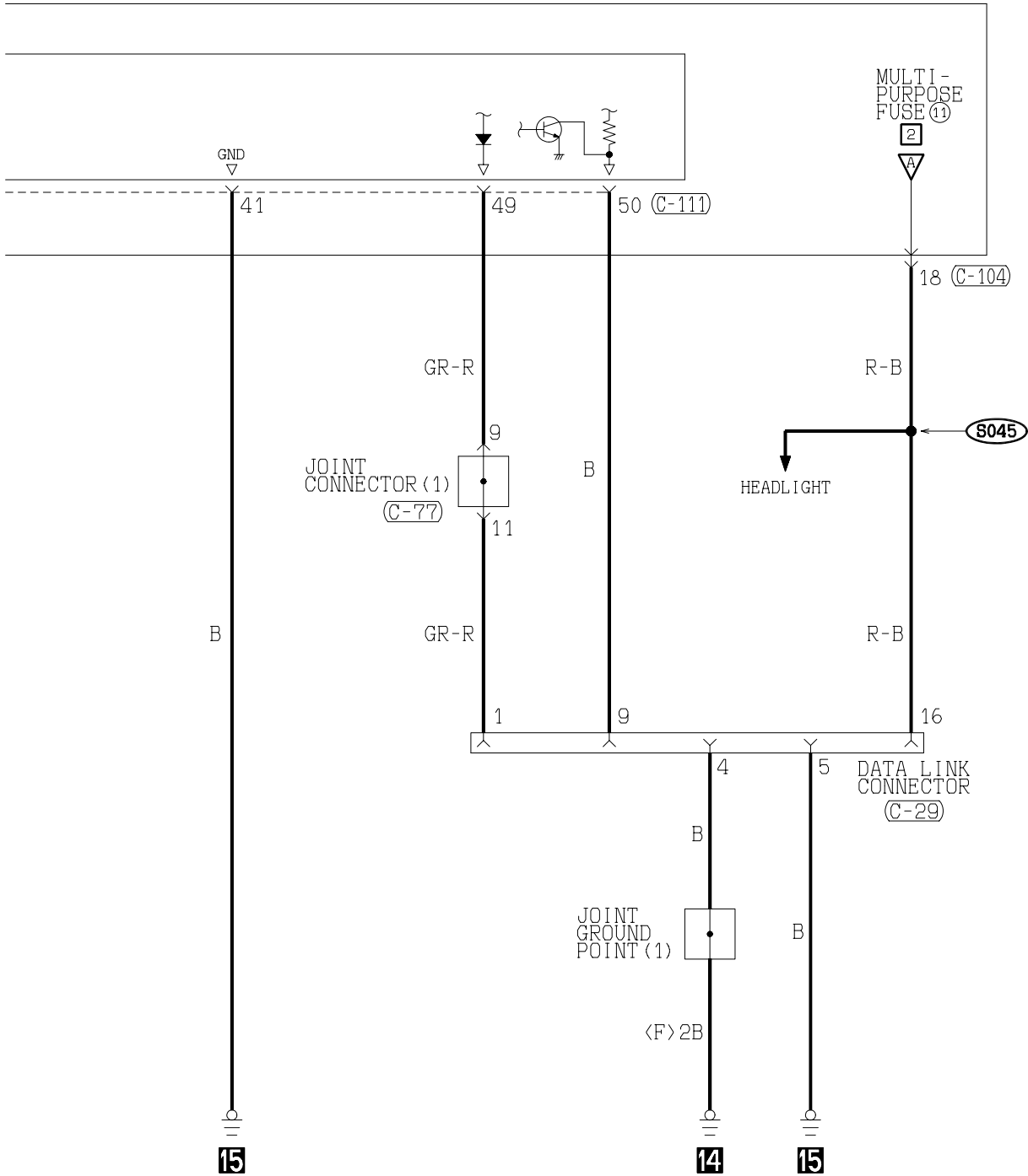

(C-113)

1	2	3	4	5	6	7	8	9	
10	11	12	13	14	15	16	17	18	19

(C-114)

1	2	3	4	5	6	7	8	9	10	11	12	13	14	15	16	17	18	19	20
---	---	---	---	---	---	---	---	---	----	----	----	----	----	----	----	----	----	----	----

(D-01)

1	2	3
---	---	---

(D-11)

1	2	3
---	---	---

WIRE COLOR CODE  
 B : BLACK BR : BROWN G : GREEN GR : GRAY L : BLUE LG : LIGHT GREEN O : ORANGE  
 P : PINK R : RED SB : SKY BLUE V : VIOLET W : WHITE Y : YELLOW

H1S11M08CB

TSB Revision

CENTRAL DOOR LOCKING SYSTEM <VEHICLES WITH KEYLESS ENTRY SYSTEM (WITH THEFT-ALARM SYSTEM) > (CONTINUED)

7

- NOTE
- \*1: VEHICLES WITH SUNROOF OR ECLIPSE SPYDER
  - \*2: VEHICLES WITHOUT SUNROOF
  - \*3: ECLIPSE
  - \*4: ECLIPSE SPYDER

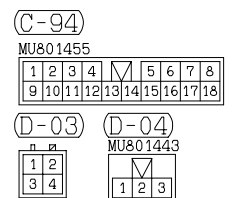
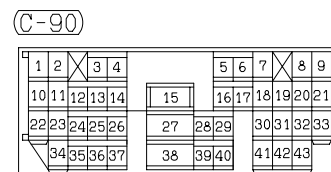
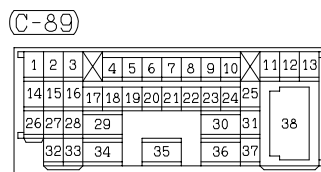
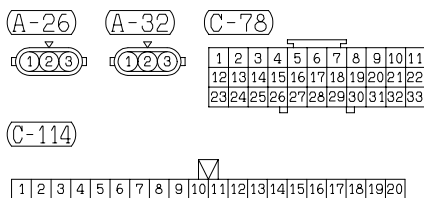
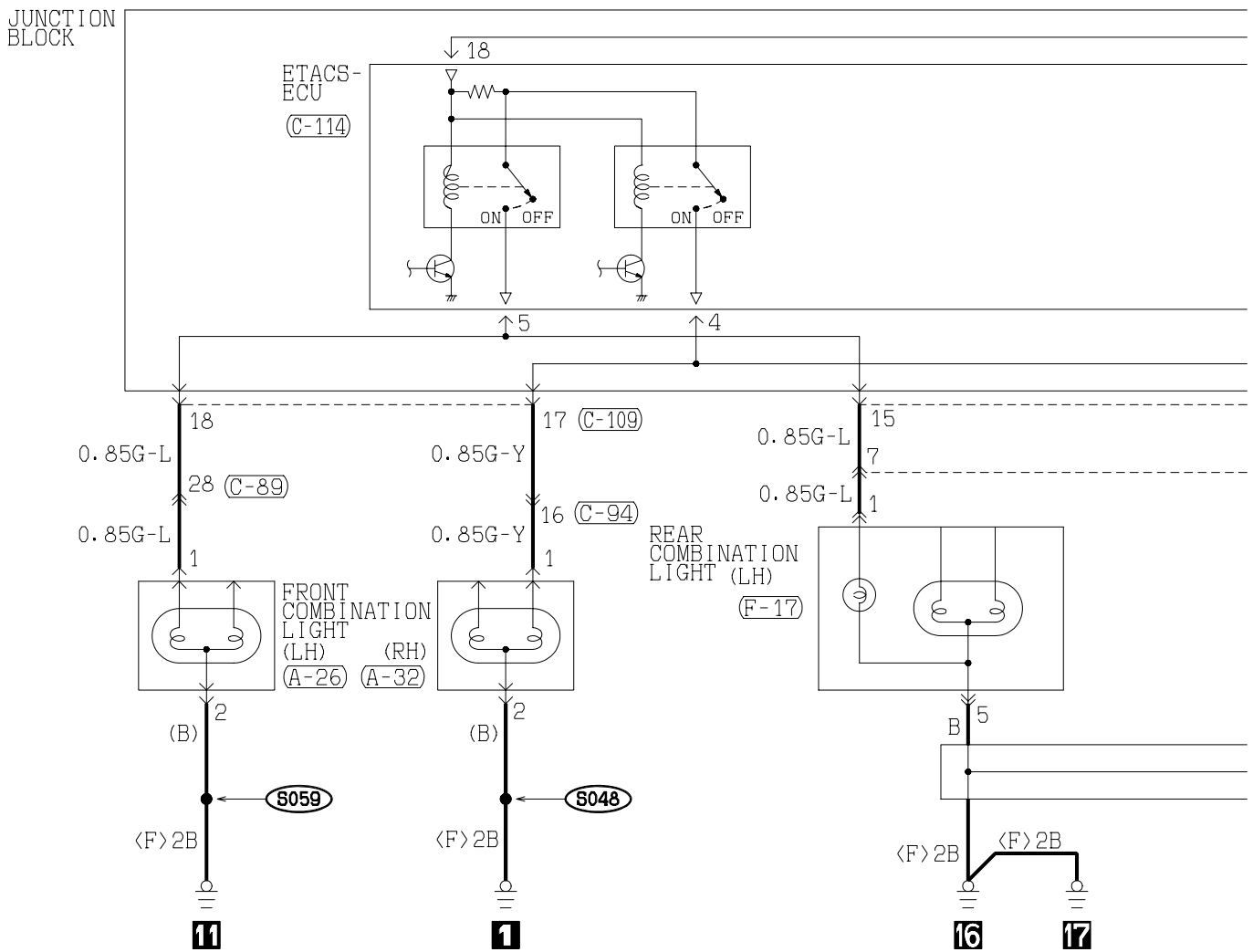

H1S11M08DA

TSB Revision



8

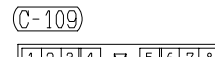
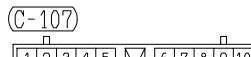
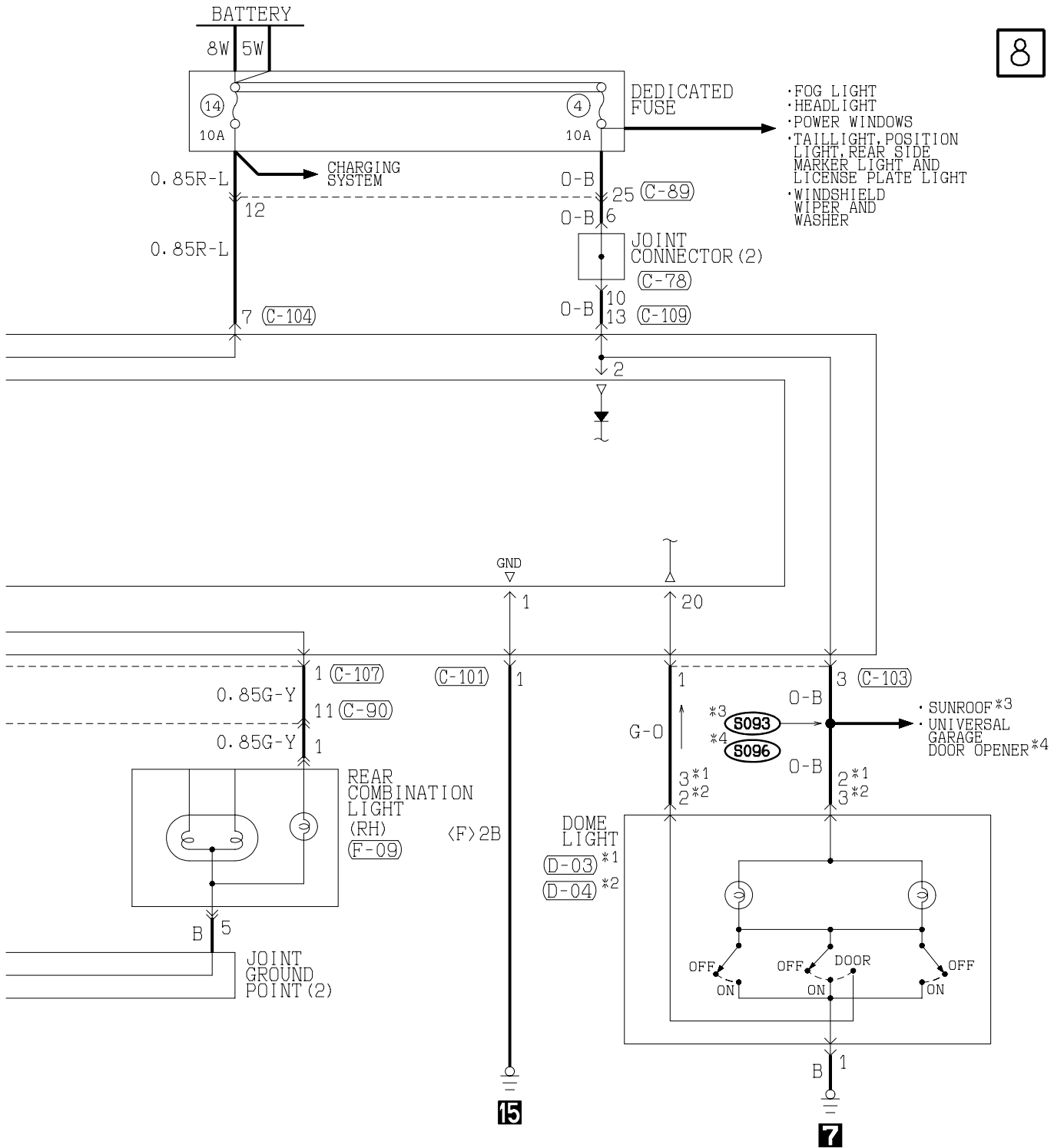

WIRE COLOR CODE

B : BLACK BR : BROWN

G : GREEN SB : SKY BLUE

GR : GRAY V : VIOLET

L : BLUE W : WHITE

LG : LIGHT GREEN Y : YELLOW

O : ORANGE

H1S11M08DB

TSB Revision

# HEATER

1

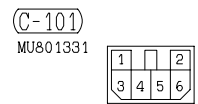
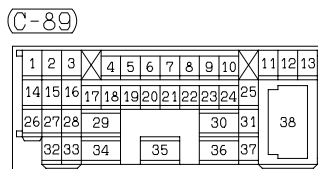
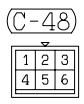
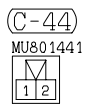
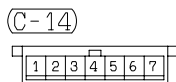
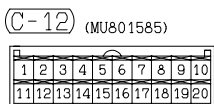
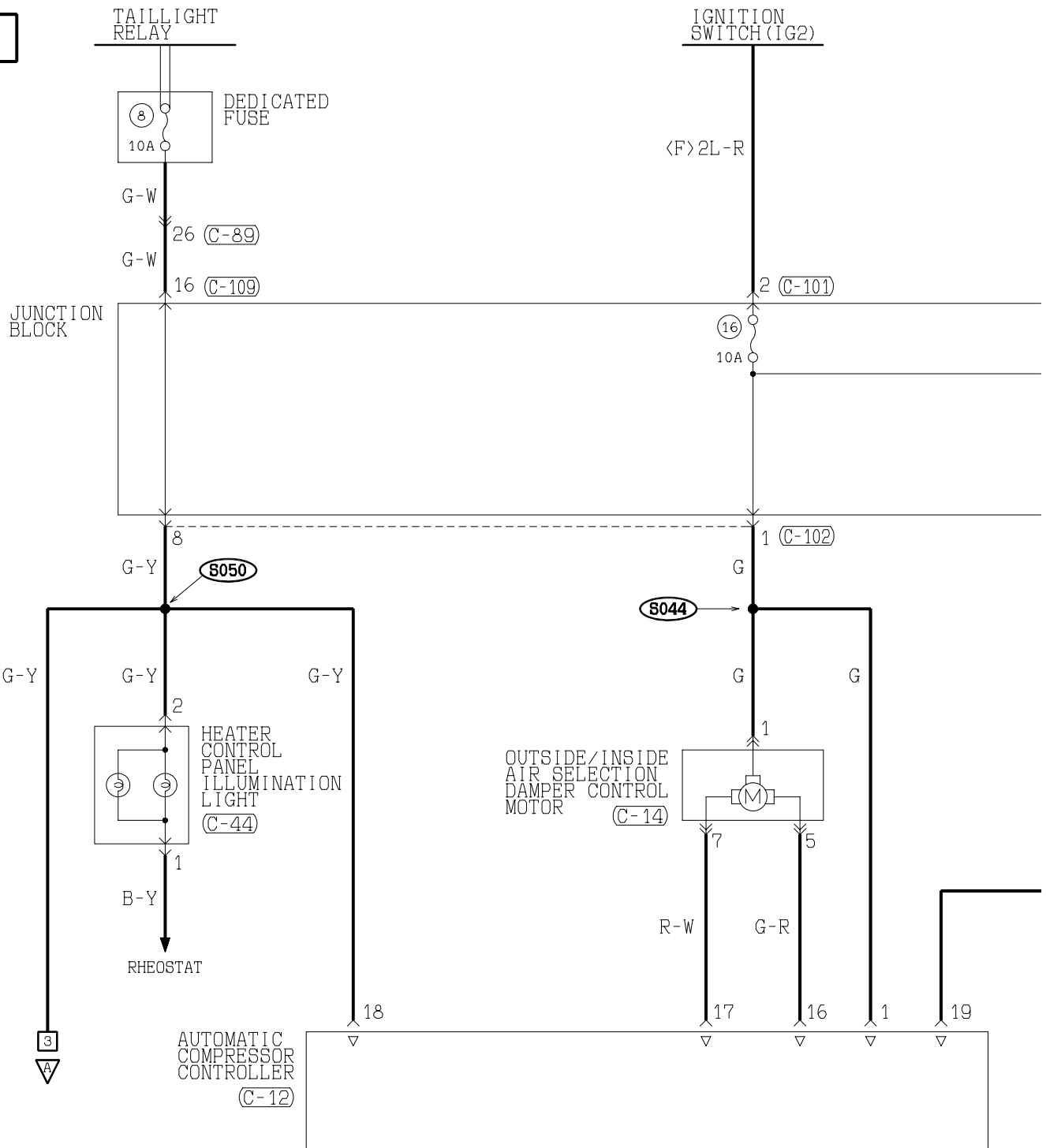

TSB Revision

2

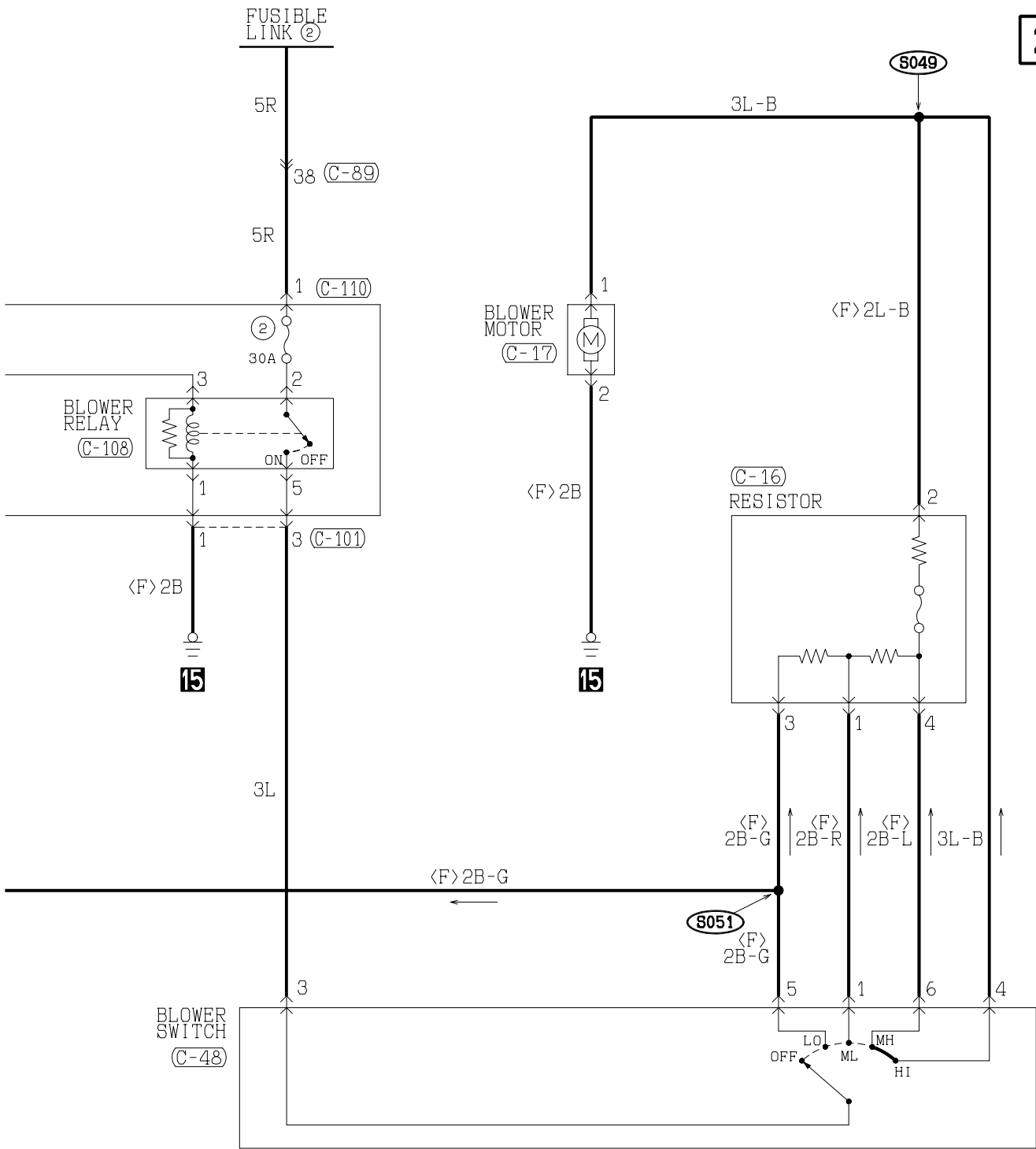

(C-102)

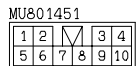

(C-108)



(C-109)

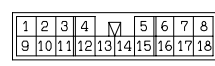

(C-110)



WIRE COLOR CODE

B : BLACK BR : BROWN G : GREEN GR : GRAY L : BLUE LG : LIGHT GREEN O : ORANGE  
P : PINK R : RED SB : SKY BLUE V : VIOLET W : WHITE Y : YELLOW

H1S12M06AB

TSB Revision

HEATER (CONTINUED)

3

AUTOMATIC COMPRESSOR CONTROLLER (C-12)

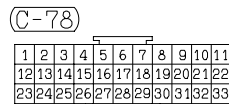
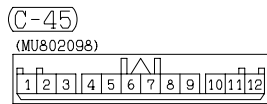
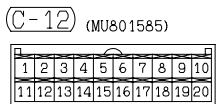
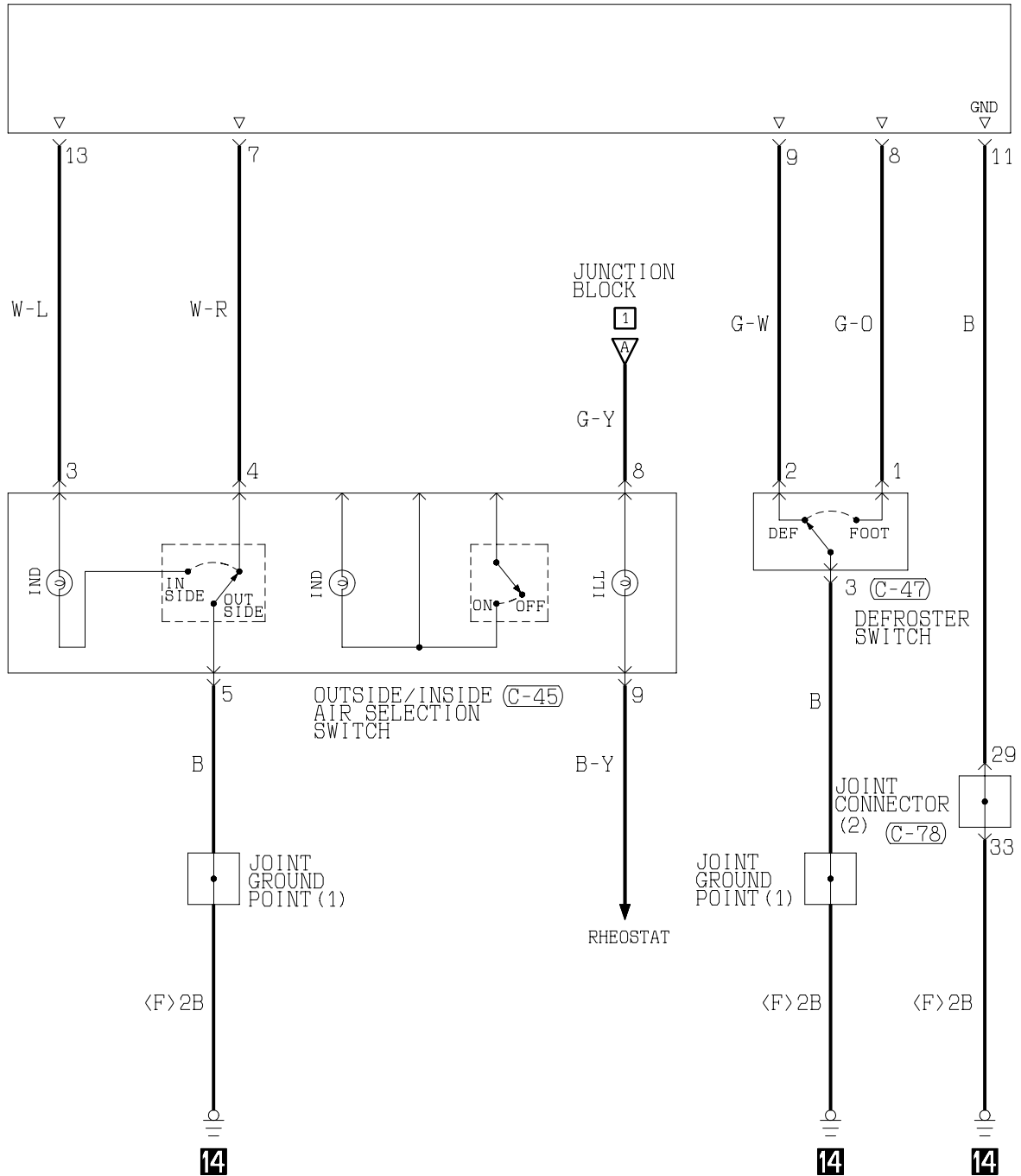

WIRE COLOR CODE  
 B : BLACK BR: BROWN G : GREEN GR: GRAY L : BLUE LG: LIGHT GREEN O : ORANGE  
 P : PINK R : RED SB: SKY BLUE V : VIOLET W : WHITE Y : YELLOW

H1S12M06BA

TSB Revision

NOTES

TSB Revision

# AIR CONDITIONING SYSTEM <2.4L ENGINE>

M1901005500161

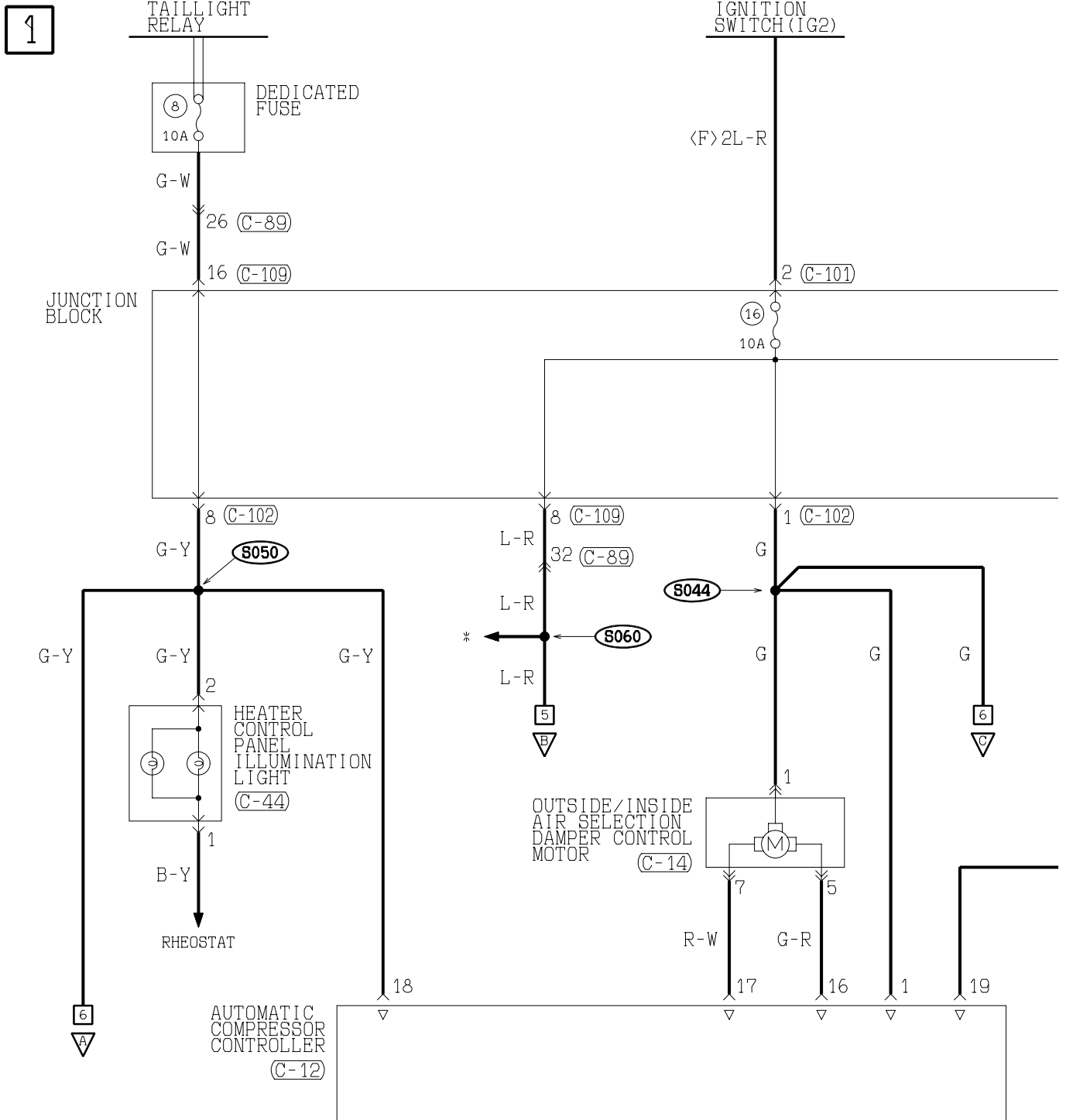

H1S12M07AA

TSB Revision

2

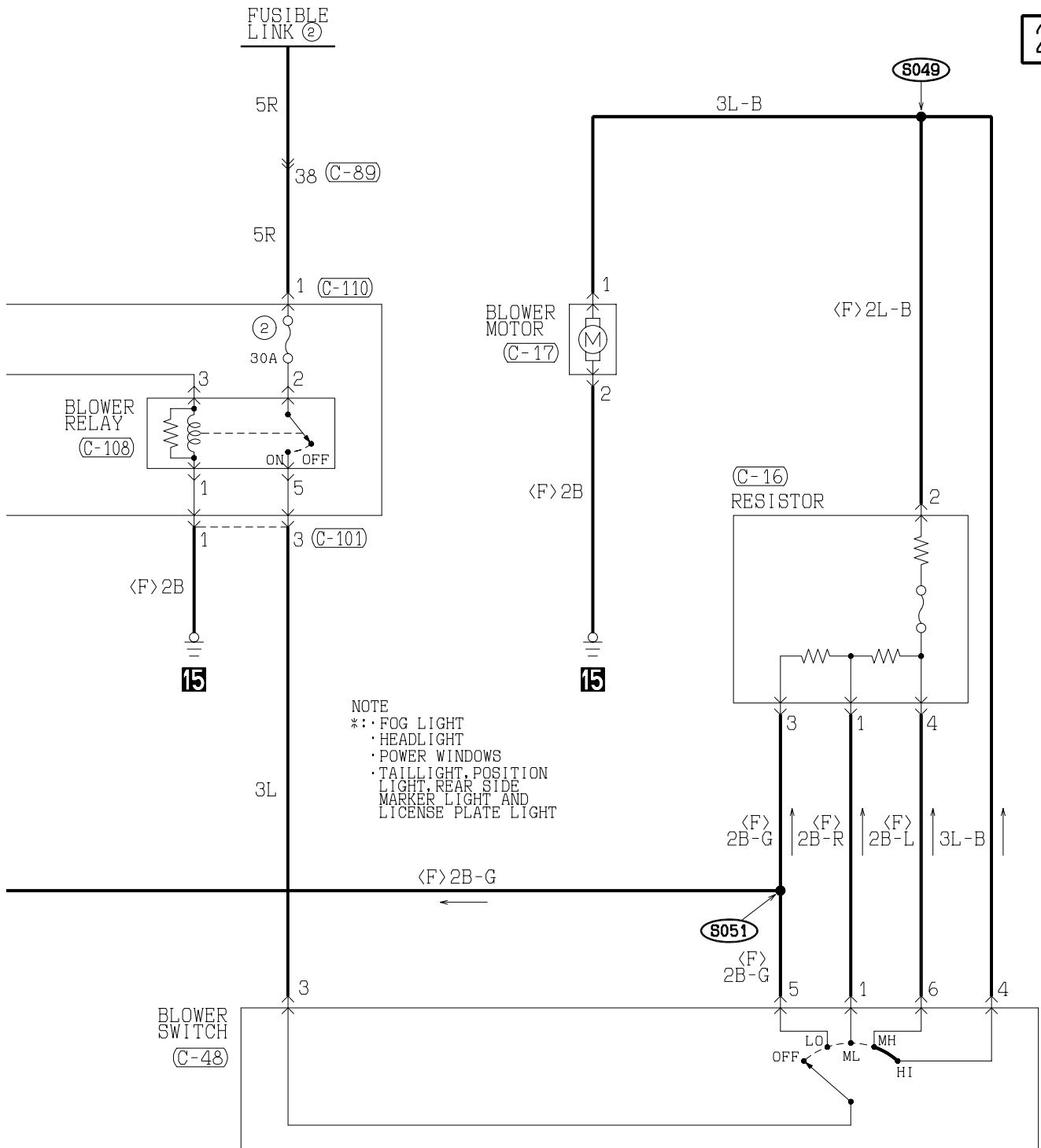

(C-102)

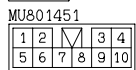

(C-108)



(C-109)

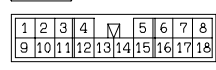

(C-110)



WIRE COLOR CODE

B : BLACK BR : BROWN G : GREEN GR : GRAY L : BLUE LG : LIGHT GREEN O : ORANGE  
P : PINK R : RED SB : SKY BLUE V : VIOLET W : WHITE Y : YELLOW

H1S12M07AB

TSB Revision

AIR CONDITIONING SYSTEM <2.4L ENGINE> (CONTINUED)

3

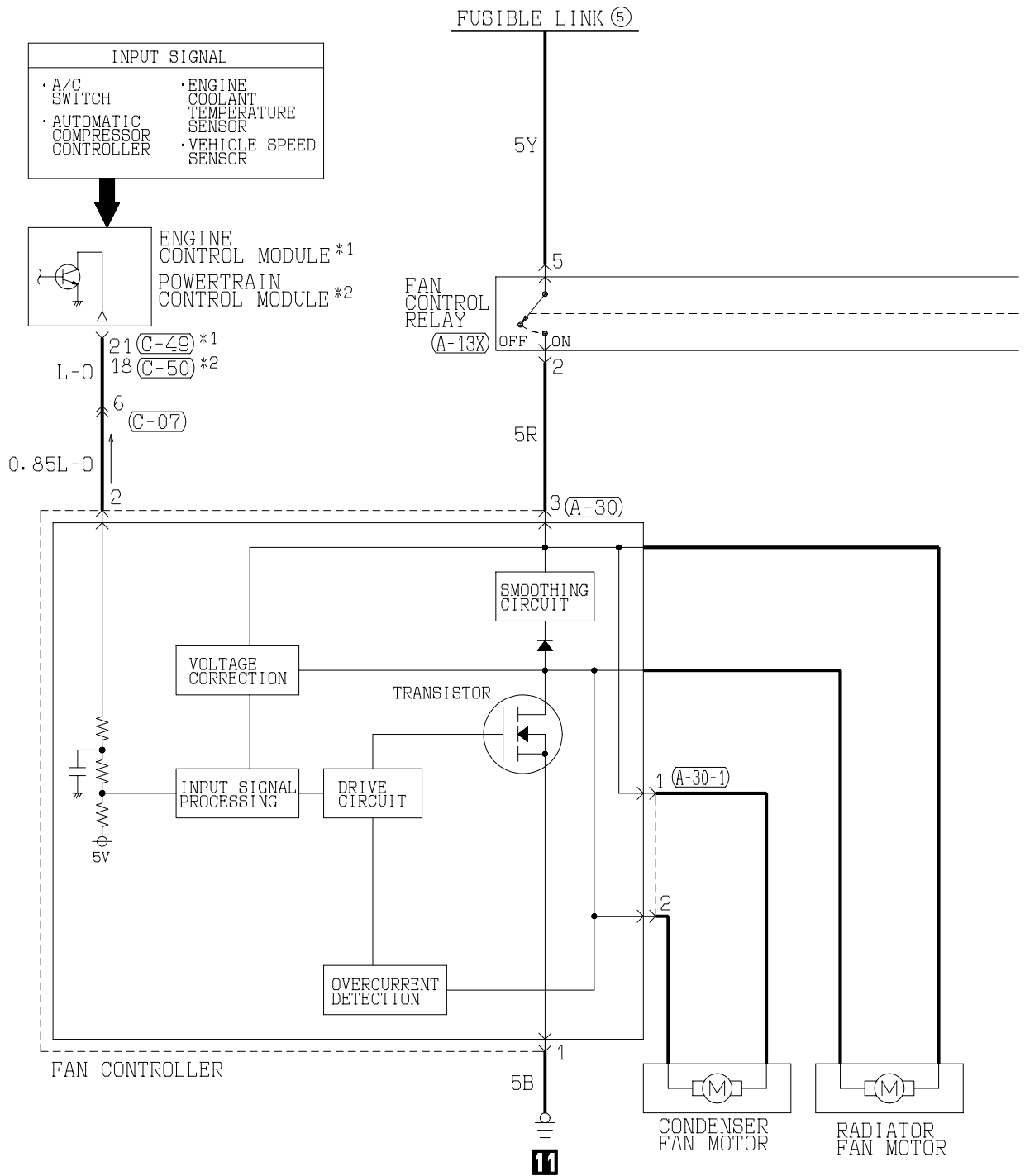

(A-13X)

2
1 3
4 5

(A-21X)

1	2
3	4

(A-30) (MU802322)

1	2	3
---	---	---

(A-30-1)

1	2
---	---

(C-07) MU801335

1	2	3	4
5	6	7	8
9	10		

(C-49) (MU803773)

1	2	3	4	5	6	7	8	9	10	11	12	13
14	15	16	17	18	19	20	21	22	23	24	25	26

(C-50) (MU803784)

1	2	3	4	5	6	7	8
9	10	11	12	13	14	15	16
17	18	19	20	21	22	23	24
25	26	27	28	29	30	31	32
33	34	35					

(C-53) (MU803771)

1	2	3	4	5	6	7	8
9	10	11	12	13	14	15	16
17	18	19	20	21	22	23	24
25	26	27	28	29	30	31	32
33	34	35	36	37	38	39	40
41	42	43	44	45	46		

TSB Revision





AIR CONDITIONING SYSTEM <2.4L ENGINE> (CONTINUED)

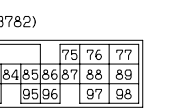
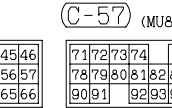
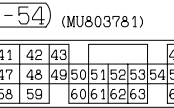
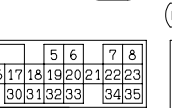
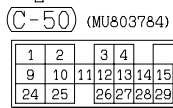
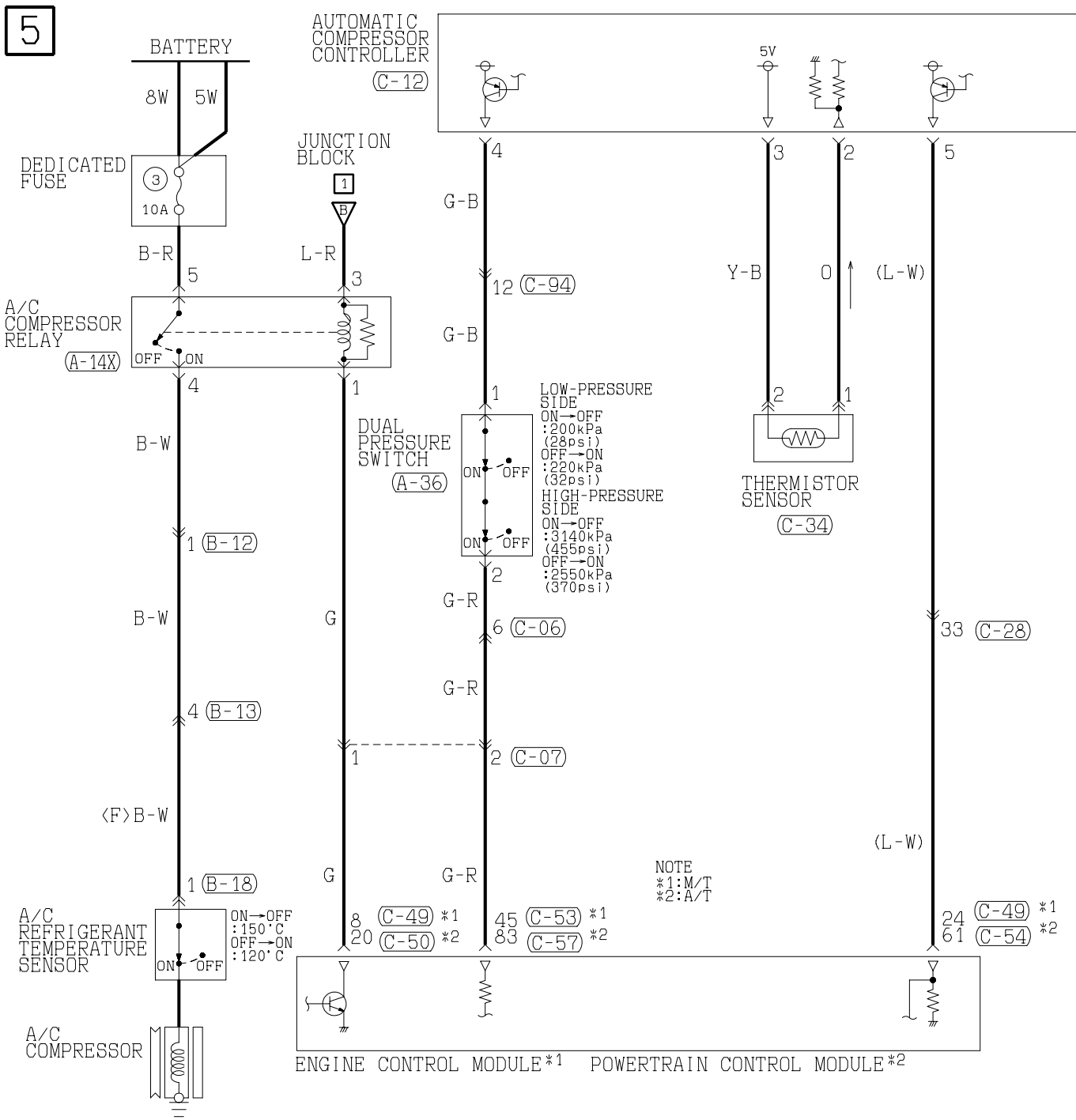

6

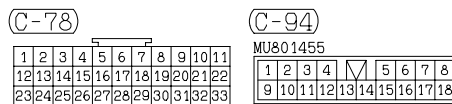
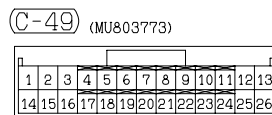
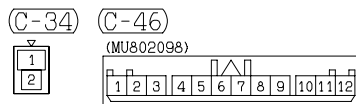
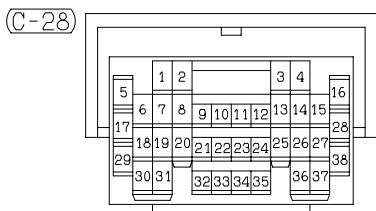
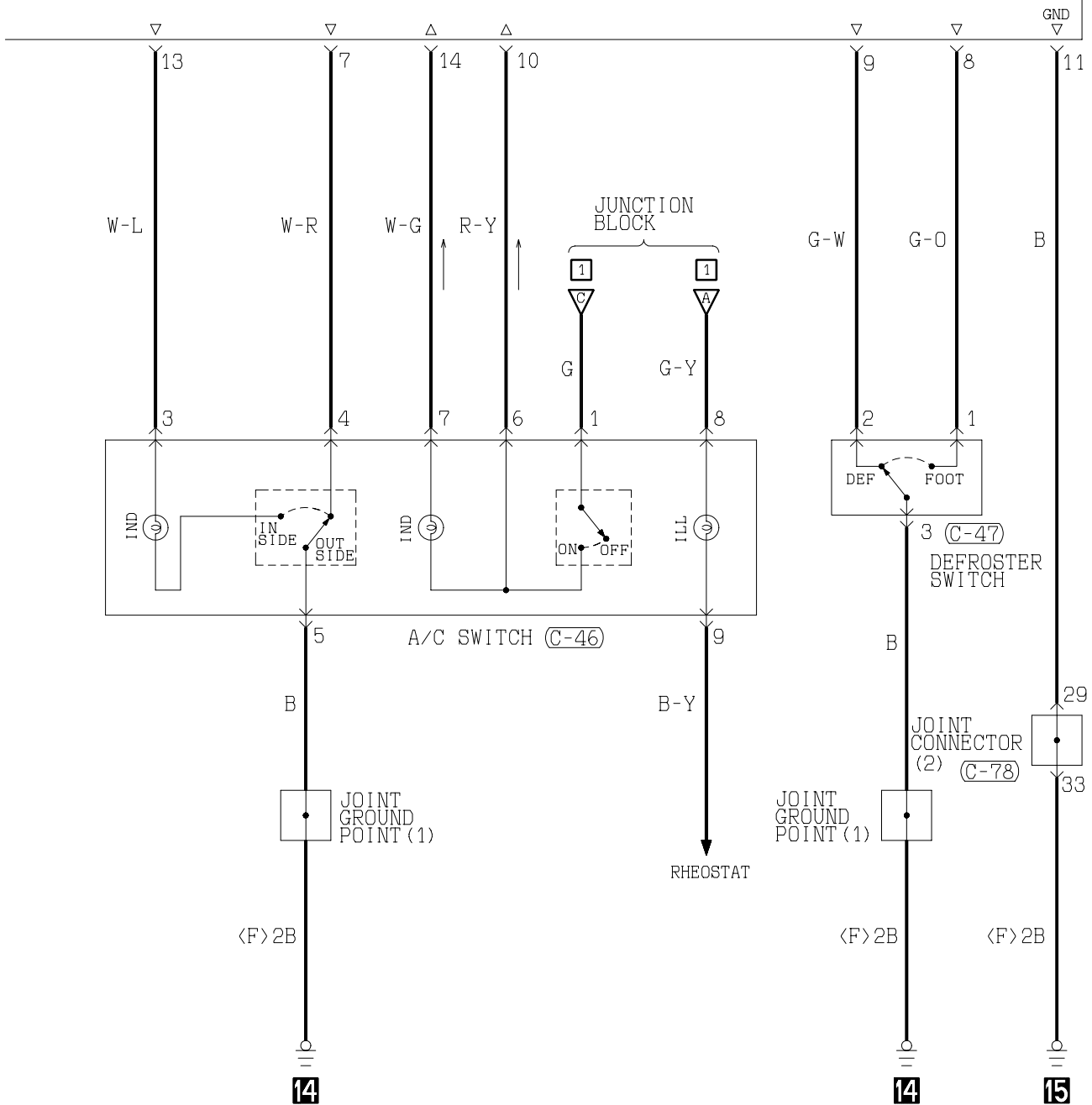

H1S12M07CB

TSB Revision

# AIR CONDITIONING SYSTEM <3.0L ENGINE>

M1901005500172

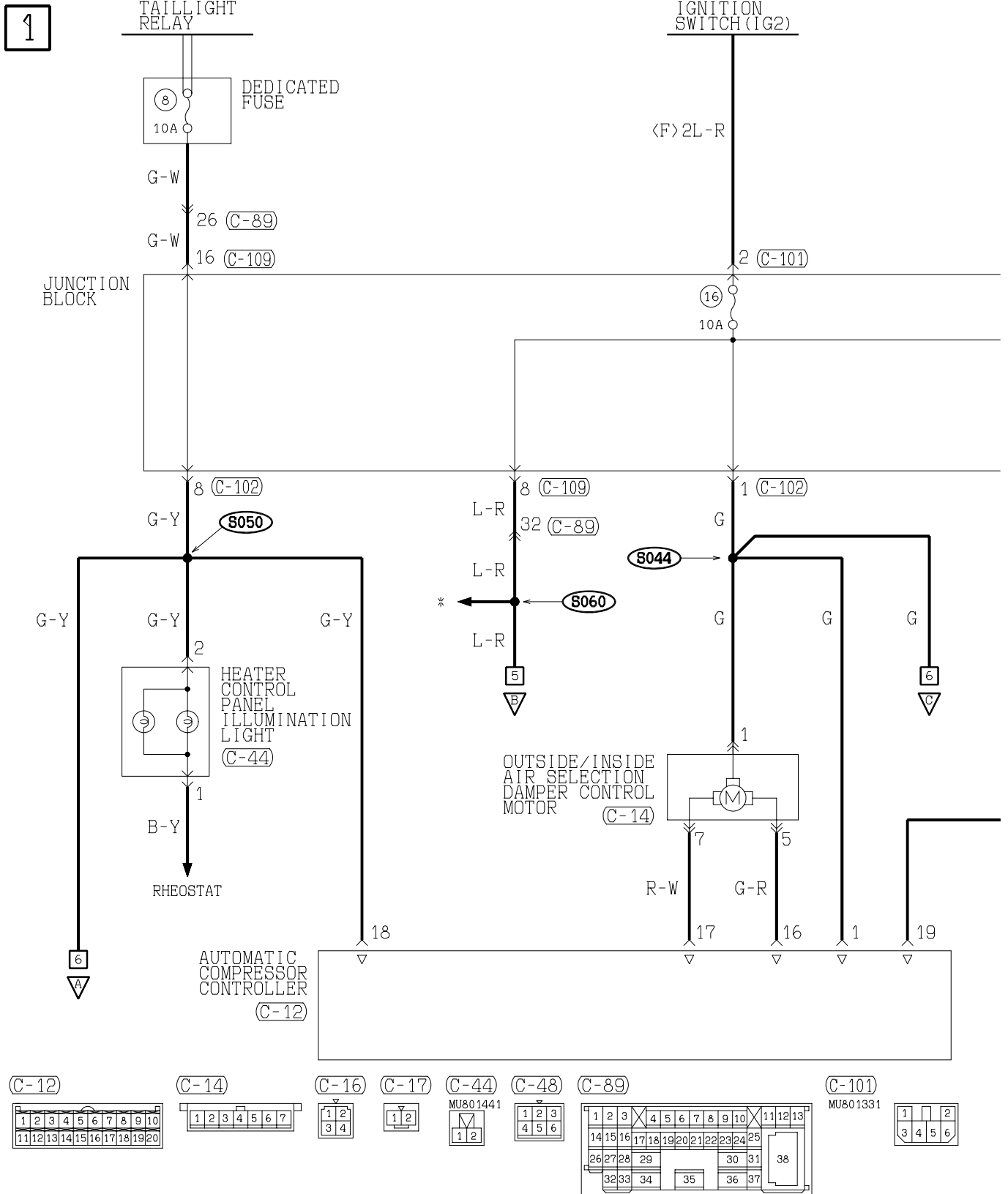

H1S12M08AA

TSB Revision

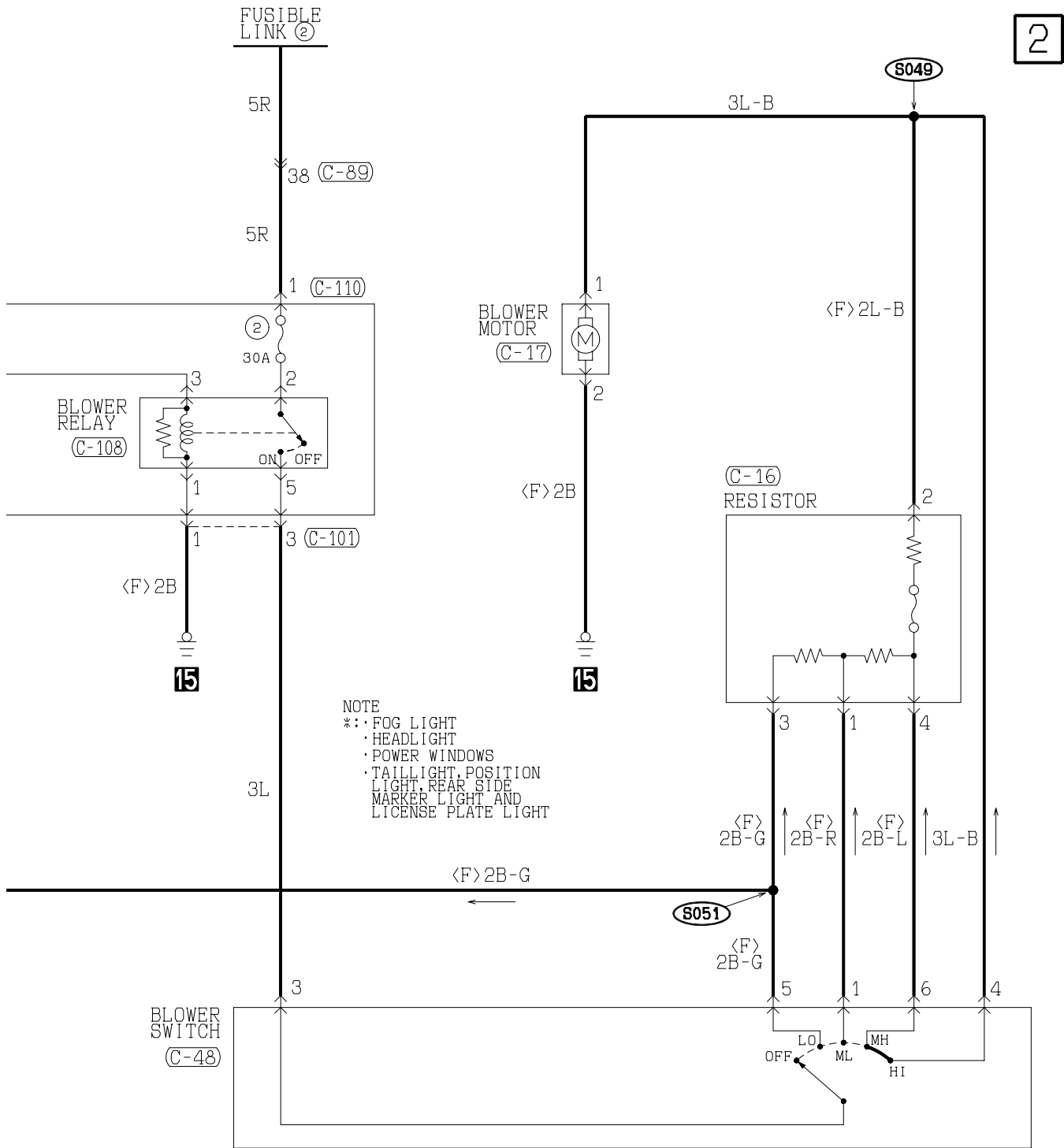

(C-102)

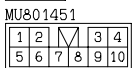

(C-108)



(C-109)

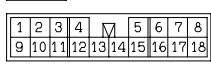

(C-110)



WIRE COLOR CODE

B : BLACK BR : BROWN G : GREEN GR : GRAY L : BLUE LG : LIGHT GREEN O : ORANGE  
P : PINK R : RED SB : SKY BLUE V : VIOLET W : WHITE Y : YELLOW

H1S12M08AB

TSB Revision

AIR CONDITIONING SYSTEM <3.0L ENGINE> (CONTINUED)

3

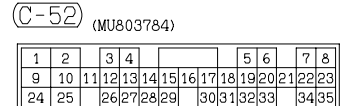
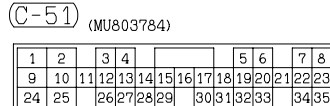
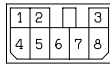
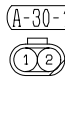
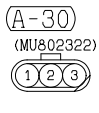
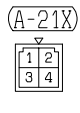
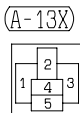
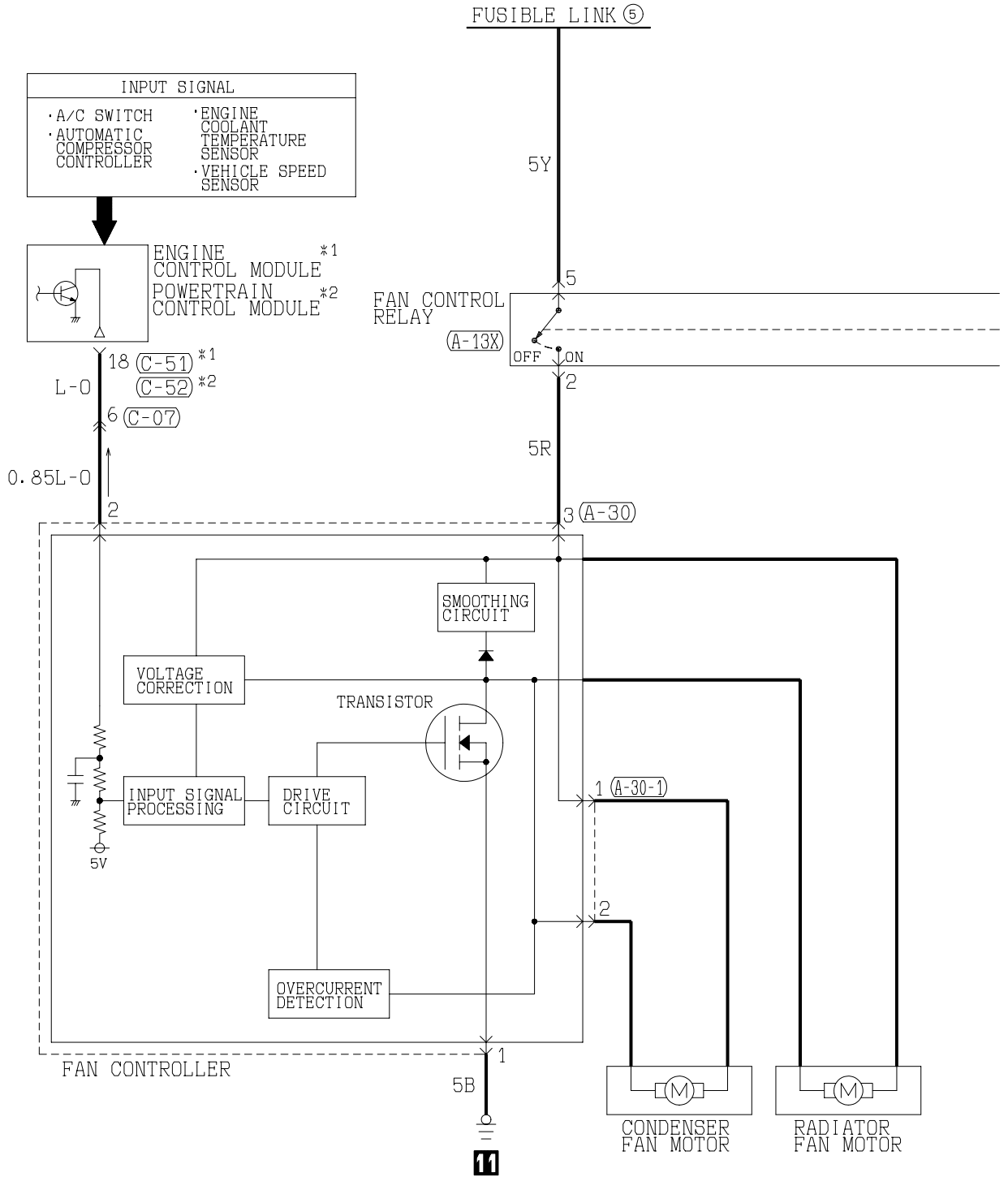

4

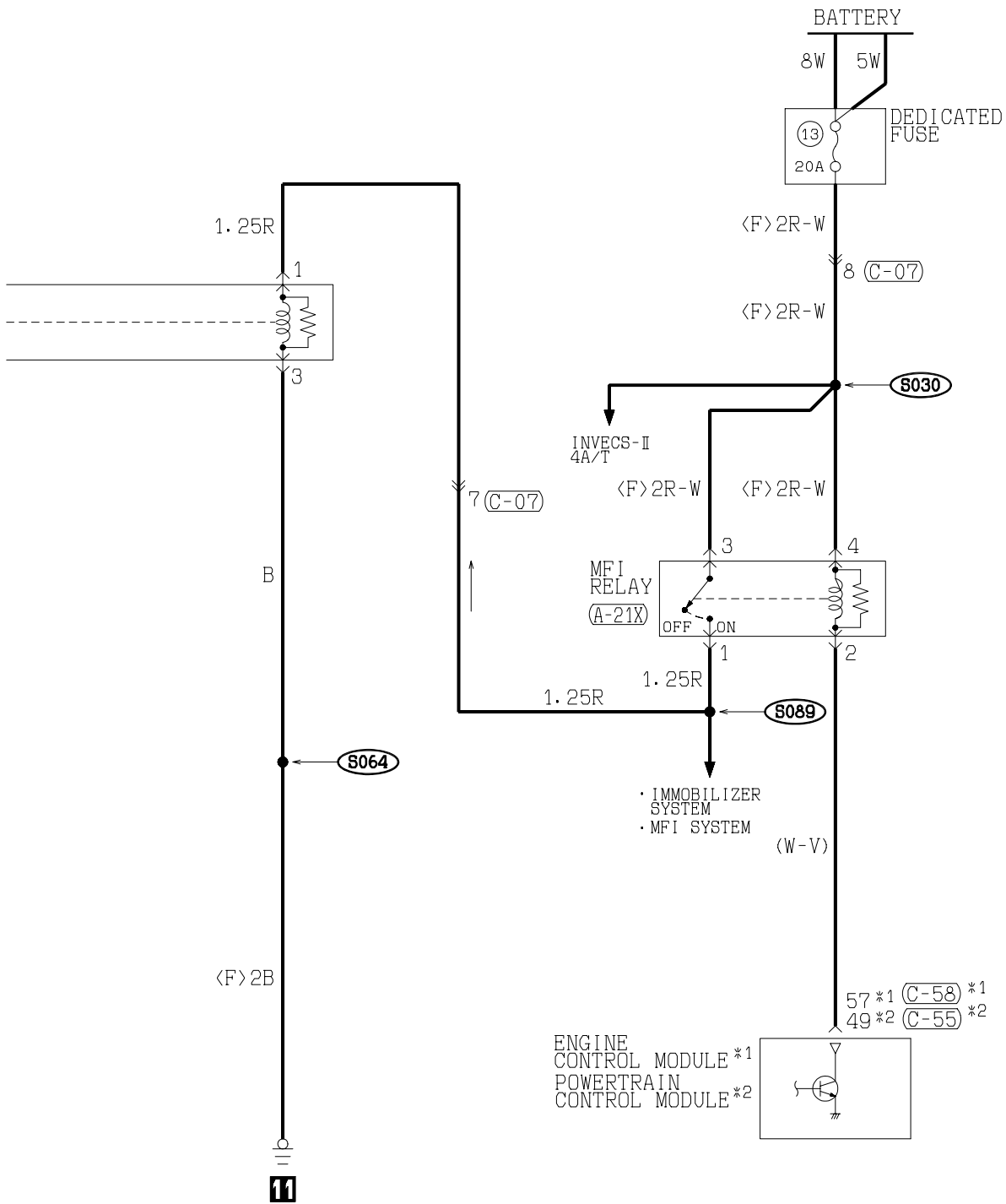

(C-55) (MU803781)

(C-58) (MU803782)

41	42	43		44	45	46
47	48	49	50	51	52	53
54	55	56	57			
58	59	60	61	62	63	64
65	66					

41	42	43	44			45	46	47
48	49	50	51	52	53	54	55	56
57	58	59						
60	61	62	63	64	65	66	67	68

WIRE COLOR CODE

B : BLACK BR : BROWN G : GREEN GR : GRAY L : BLUE LG : LIGHT GREEN O : ORANGE  
P : PINK R : RED SB : SKY BLUE V : VIOLET W : WHITE Y : YELLOW

H1S12M08BB

TSB Revision

AIR CONDITIONING SYSTEM <3.0L ENGINE> (CONTINUED)

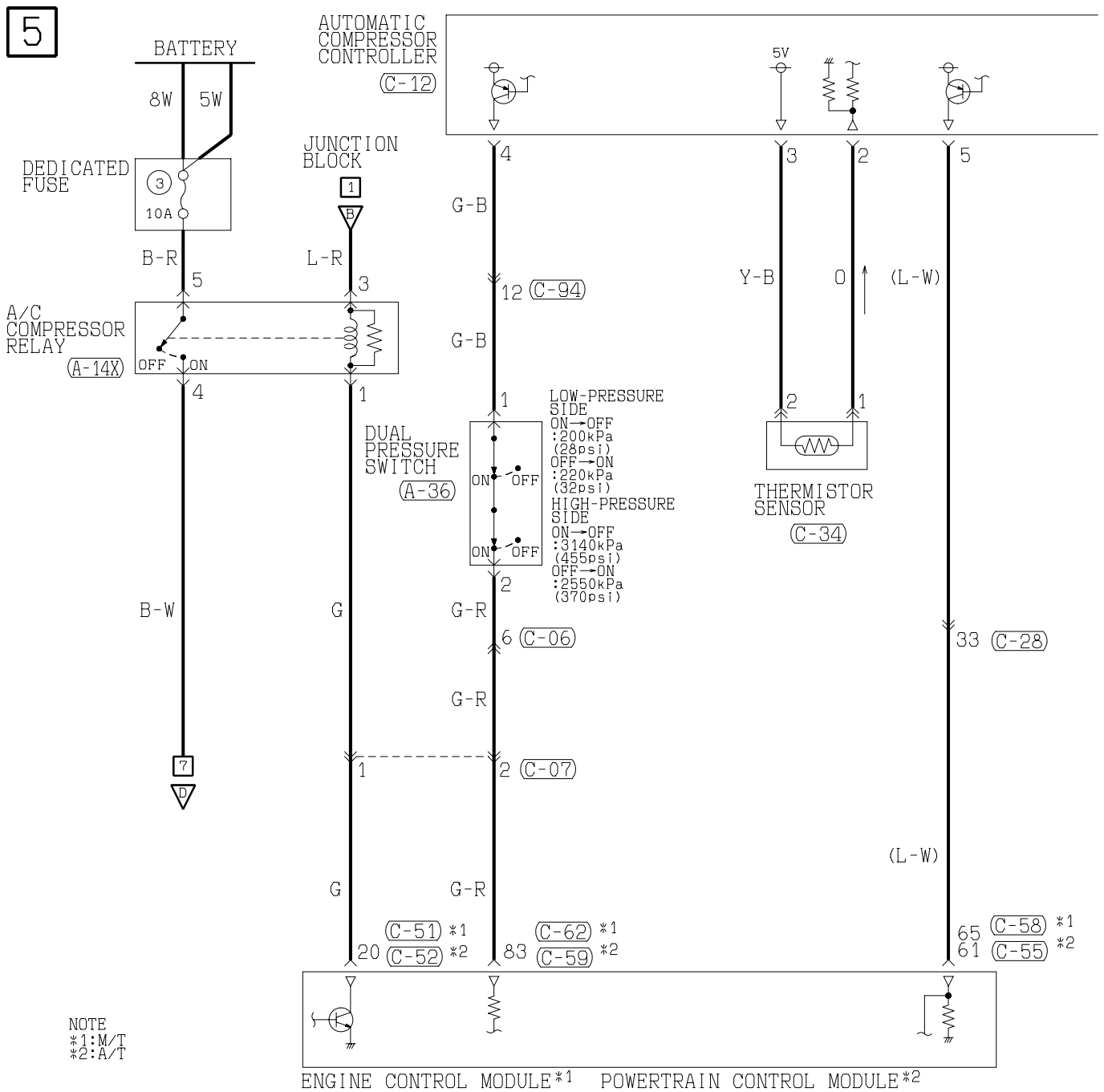

(A-14X)



(A-36)



(C-06)

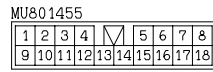

(C-07)



(C-12) (MU801585)

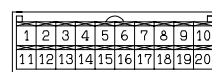

(C-28)

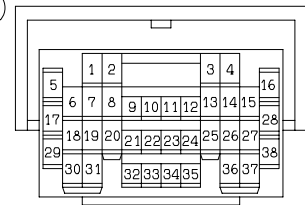

(C-34)



(C-58) (MU803782)

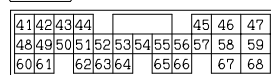

(C-59) (MU803782)

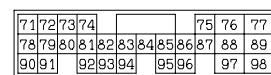

(C-62) (MU803783)

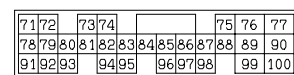

H1S12M08CA



6

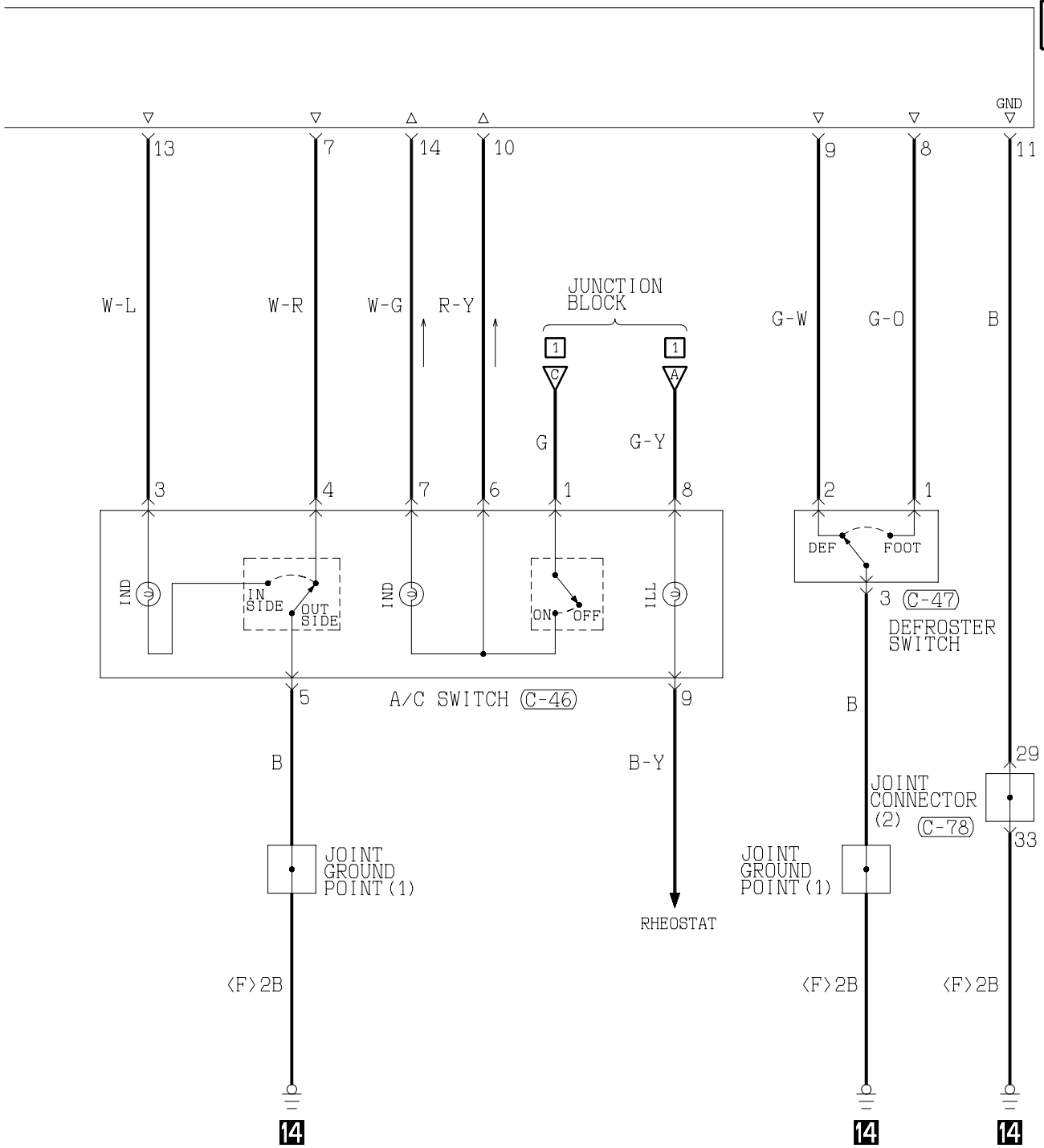

(C-46) (MU802098)

1	2	3	4	5	6	7	8	9	10	11	12
---	---	---	---	---	---	---	---	---	----	----	----

(C-47)

1	2	3
---	---	---

(C-51) (MU803784)

1	2	3	4	5	6	7	8							
9	10	11	12	13	14	15	16	17	18	19	20	21	22	23
24	25	26	27	28	29	30	31	32	33	34	35			

(C-52) (MU803784)

1	2	3	4	5	6	7	8							
9	10	11	12	13	14	15	16	17	18	19	20	21	22	23
24	25	26	27	28	29	30	31	32	33	34	35			

(C-55) (MU803781)

41	42	43	44	45	46					
47	48	49	50	51	52	53	54	55	56	57
58	59	60	61	62	63	64	65	66		

(C-78)

1	2	3	4	5	6	7	8	9	10	11
12	13	14	15	16	17	18	19	20	21	22
23	24	25	26	27	28	29	30	31	32	33

(C-94)

MU801455

1	2	3	4	5	6	7	8		
9	10	11	12	13	14	15	16	17	18

**WIRE COLOR CODE**

- B : BLACK      LG : LIGHT GREEN      G : GREEN      L : BLUE
- BR : BROWN    O : ORANGE            GR : GRAY      R : RED
- W : WHITE      SB : SKY BLUE        P : PINK        Y : YELLOW
- V : VIOLET

H1S12M08CB

**TSB Revision**

AIR CONDITIONING SYSTEM <3.0L ENGINE> (CONTINUED)

7

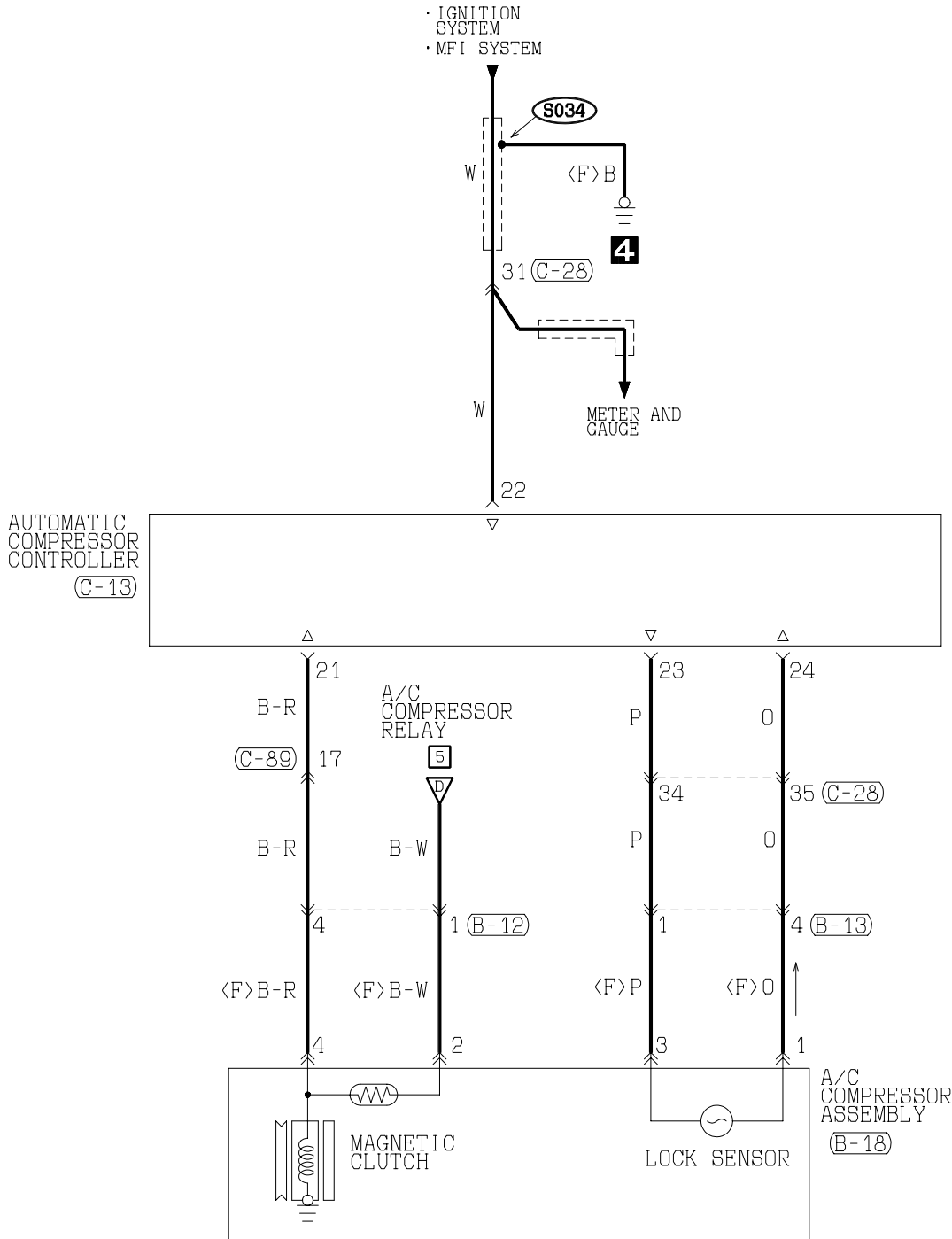

(B-12)  
MU802351



(B-13)  
MU802749

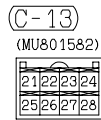
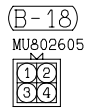
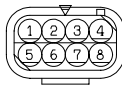

(C-28)

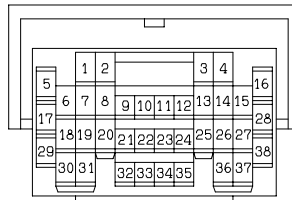

(C-89)

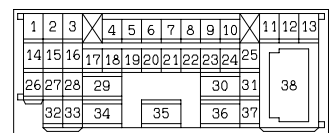

H1S12M08DA

TSB Revision

NOTES

TSB Revision

# WINDSHIELD WIPER AND WASHER

M1901006100070

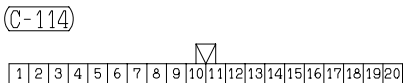
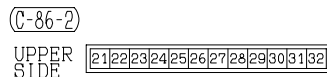
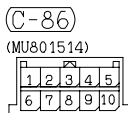
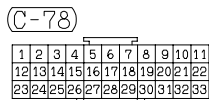
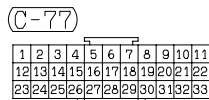
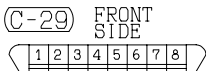
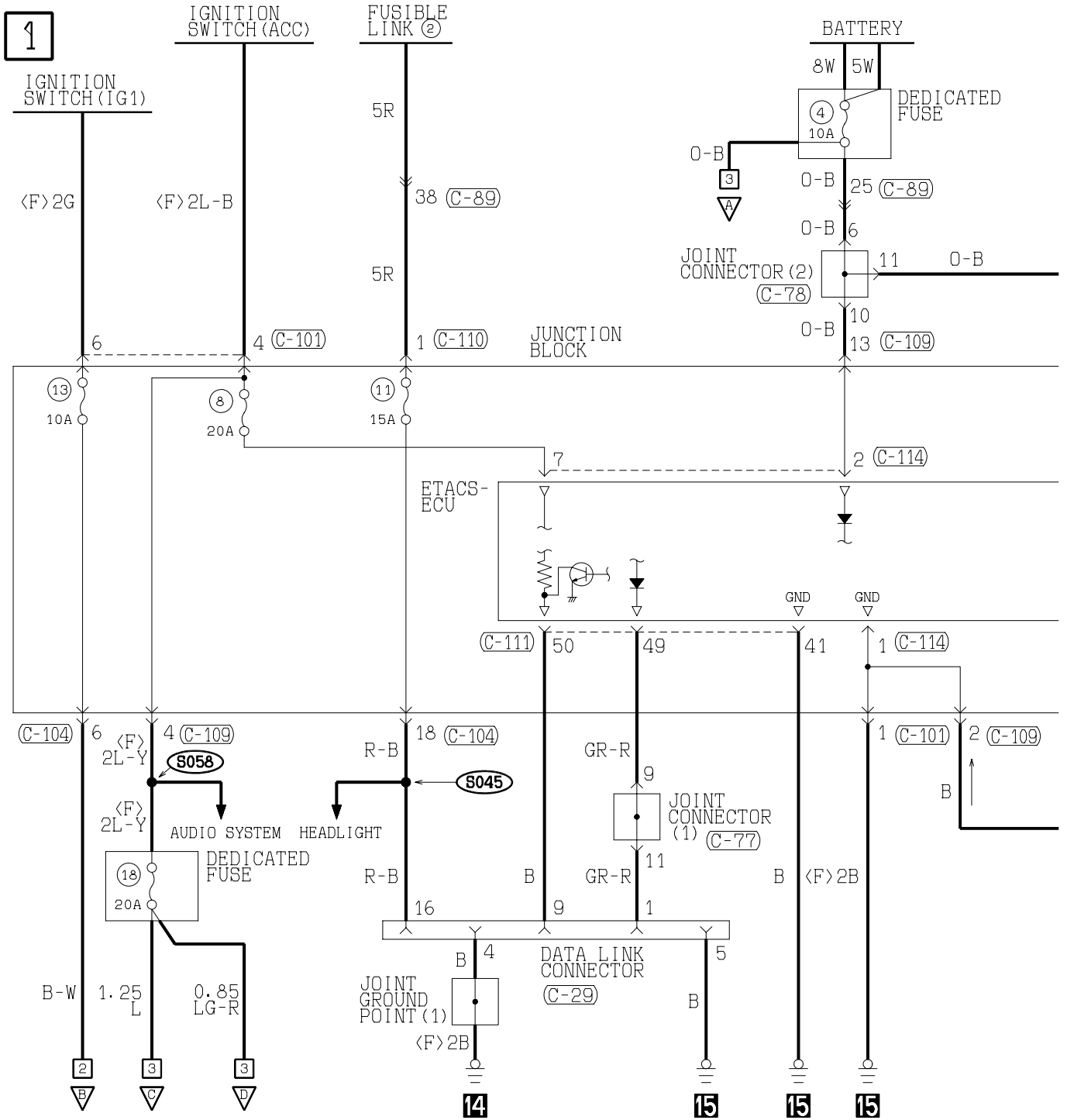

H1S13M06AA

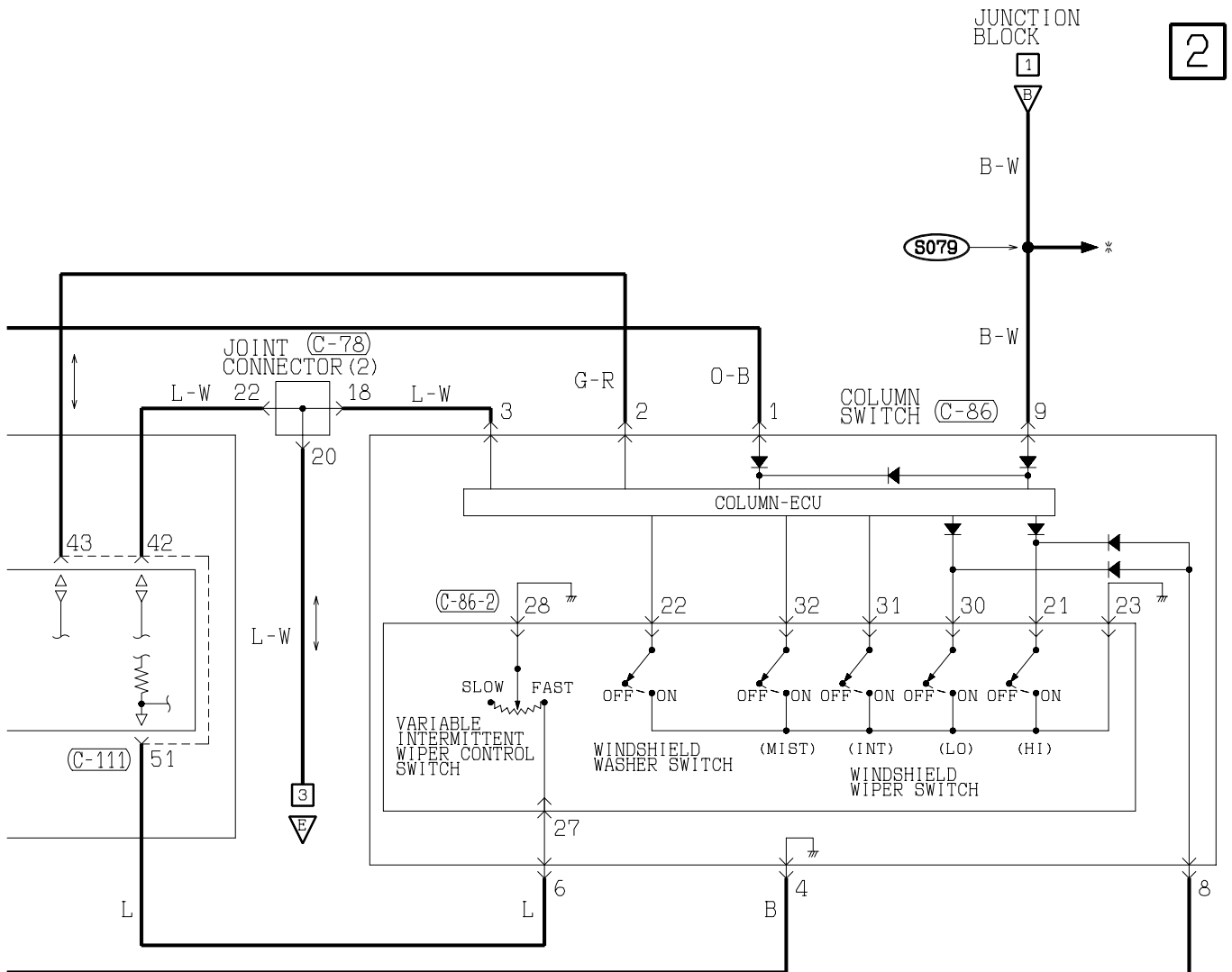

NOTE

- \*: ANTI-LOCK BRAKING SYSTEM
- AUTO-CRUISE CONTROL SYSTEM
- BRAKE WARNING LIGHT
- CHARGING SYSTEM
- FUEL WARNING LIGHT
- INVECS-II 4A/T
- METER AND GAUGE
- MFI SYSTEM
- MULTI CENTER DISPLAY
- OIL PRESSURE WARNING LIGHT
- SEAT BELT TONE ALARM
- SUPPLEMENTAL RESTRAINT SYSTEM

(C-89)

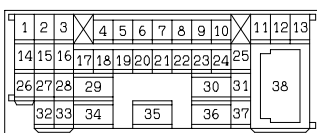

(C-101)

MU801331



(C-104)

MU801457



(C-109)

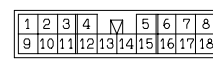

(C-110)



(C-111)

(MU801584)

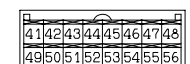

WIRE COLOR CODE

- B : BLACK
- BR : BROWN
- W : WHITE
- V : VIOLET
- LG : LIGHT GREEN
- O : ORANGE
- SB : SKY BLUE
- G : GREEN
- GR : GRAY
- P : PINK
- L : BLUE
- R : RED
- Y : YELLOW

H1S13M06AB

TSB Revision

WINDSHIELD WIPER AND WASHER (CONTINUED)

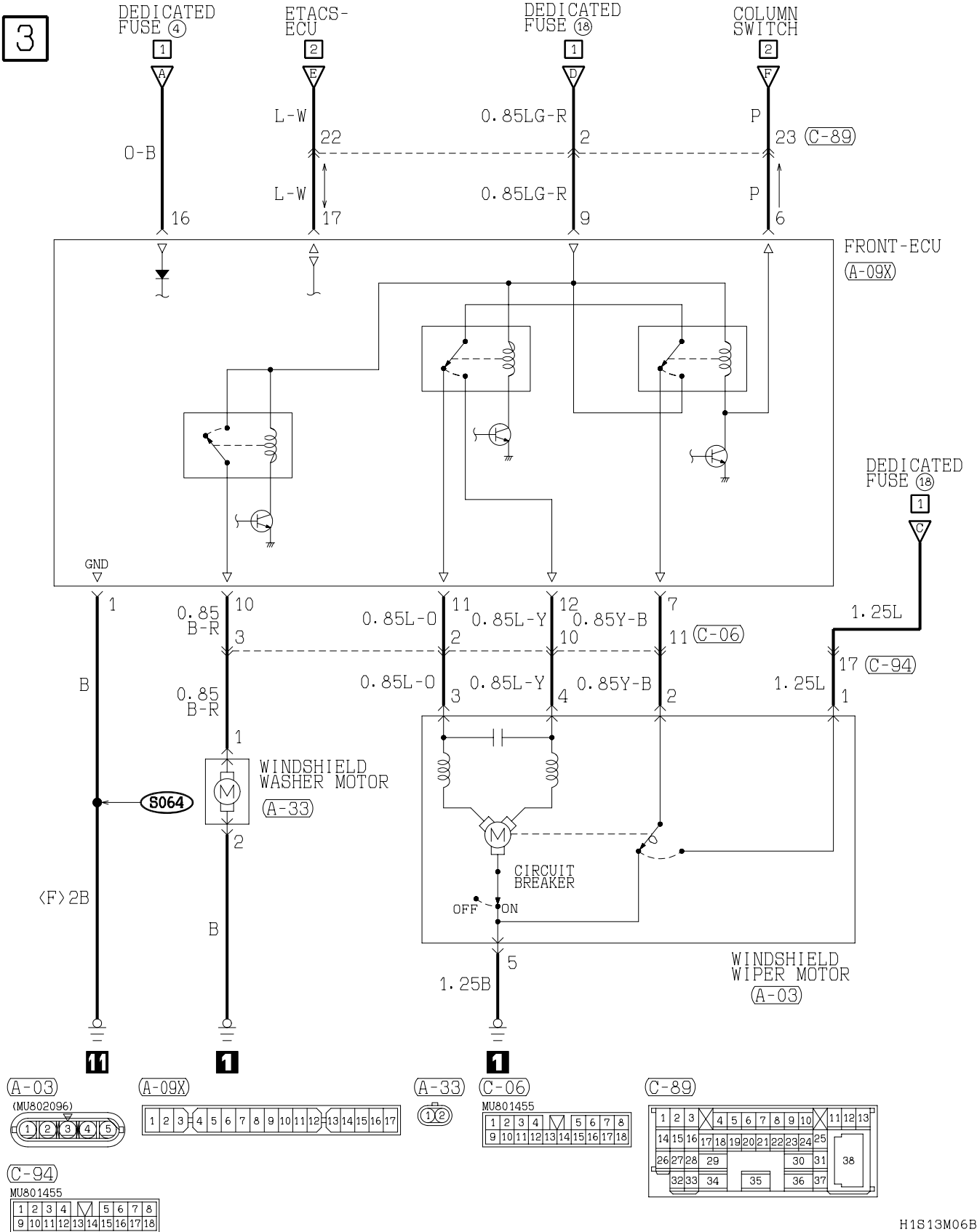

H1S13M06BA

NOTES

TSB Revision





2

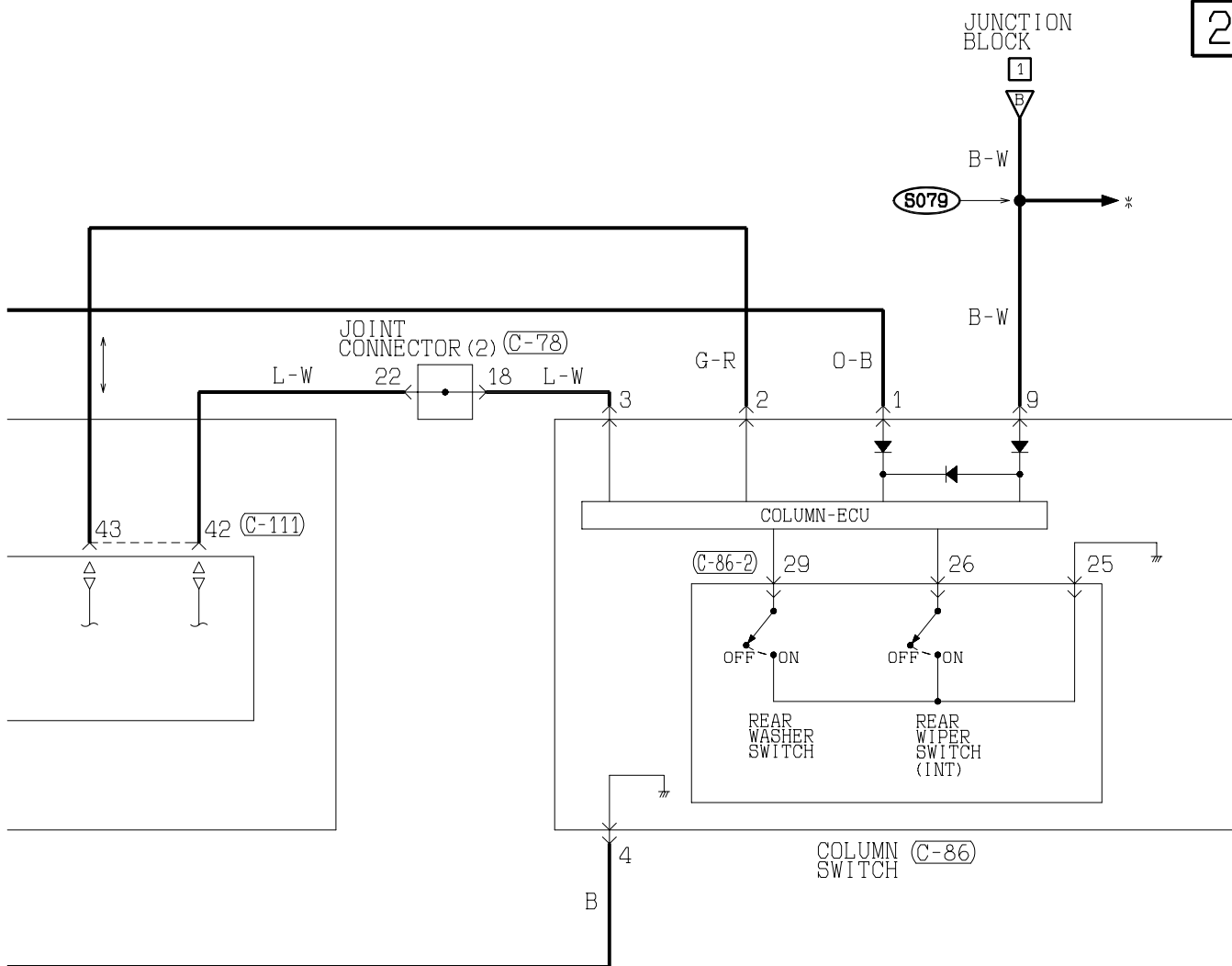

NOTE

- \*: ANTI-LOCK BRAKING SYSTEM
- AUTO-CRUISE CONTROL SYSTEM
- BRAKE WARNING LIGHT
- CHARGING SYSTEM
- FUEL WARNING LIGHT
- INVECS-II 4A/T
- METER AND GAUGE
- MFI SYSTEM
- MULTI CENTER DISPLAY
- OIL PRESSURE WARNING LIGHT
- SEAT BELT TONE ALARM
- SUPPLEMENTAL RESTRAINT SYSTEM

(C-89)

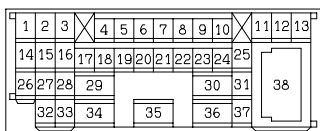

(C-101) MU801331



(C-104) MU801457

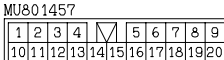

(C-109)

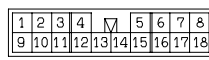

(C-110)



(C-111) (MU801584)

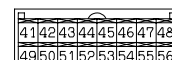

WIRE COLOR CODE

- B : BLACK
- BR : BROWN
- W : WHITE
- V : VIOLET
- LG : LIGHT GREEN
- O : ORANGE
- SB : SKY BLUE
- G : GREEN
- GR : GRAY
- P : PINK
- L : BLUE
- R : RED
- Y : YELLOW

H1S13M07AB

TSB Revision

REAR WIPER AND WASHER <M/T> (CONTINUED)

3

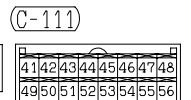
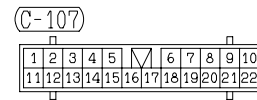
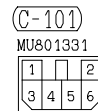
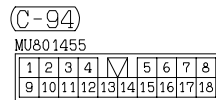
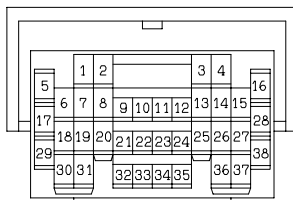
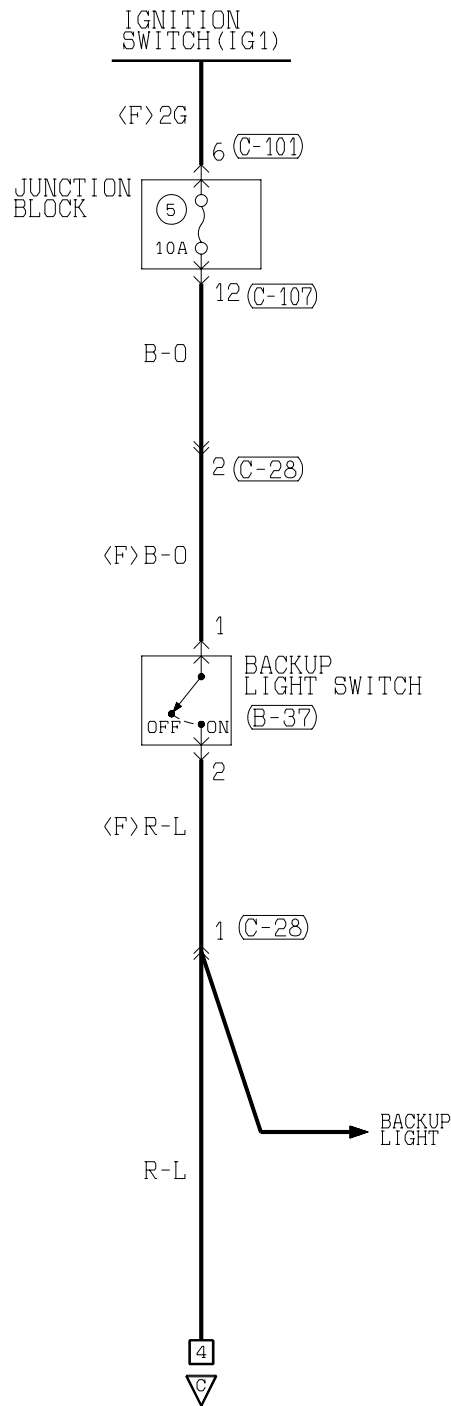

H1S13M07BA

TSB Revision

4

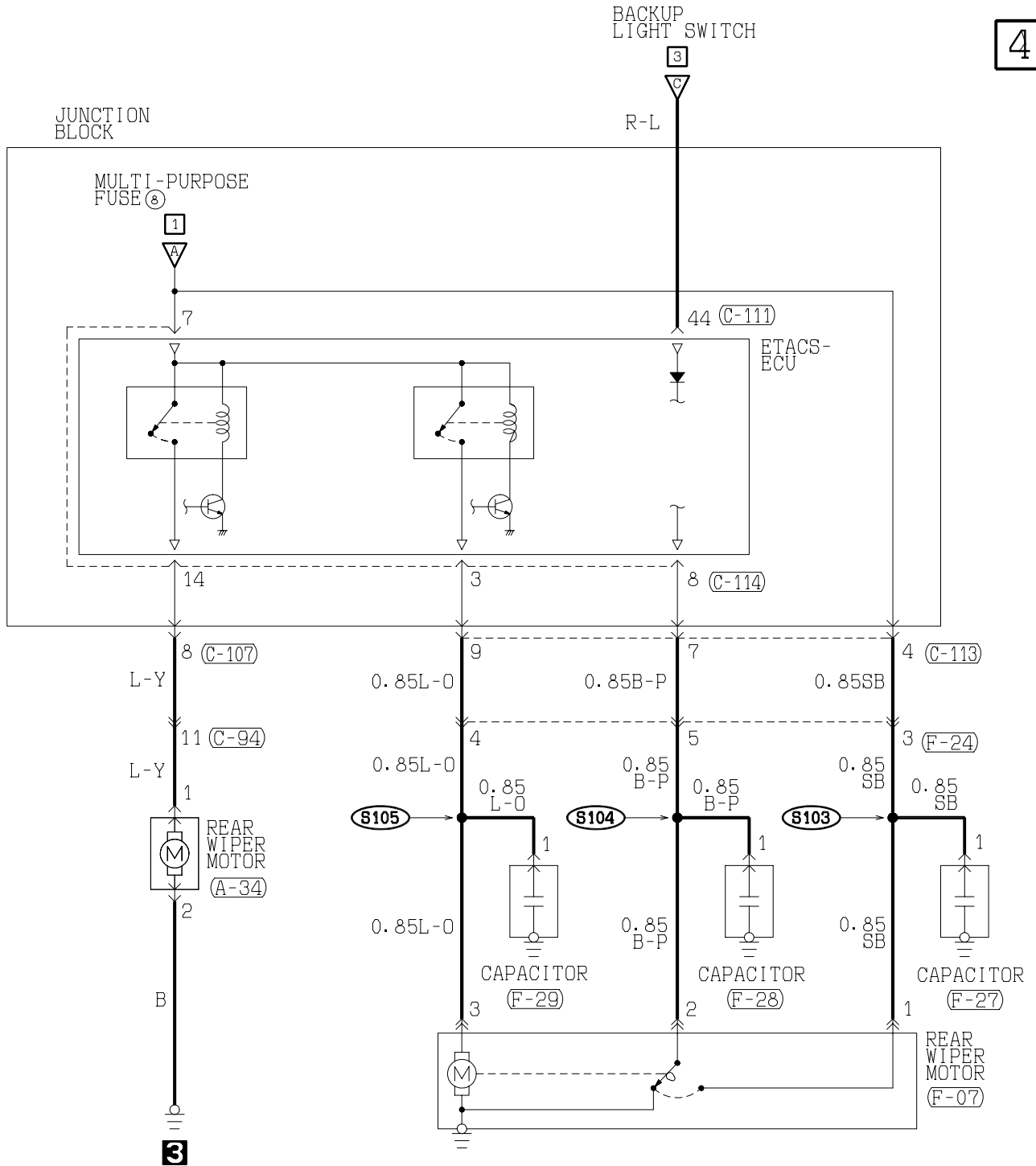

(C-113)

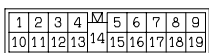

(C-114)

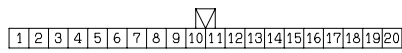

(F-07)



(F-24)

MU801543 MU801331



(F-27)



(F-28)



(F-29)



WIRE COLOR CODE

B : BLACK BR : BROWN G : GREEN GR : GRAY L : BLUE LG : LIGHT GREEN O : ORANGE  
 P : PINK R : RED SB : SKY BLUE V : VIOLET W : WHITE Y : YELLOW

H1S13M07BB

TSB Revision

# REAR WIPER AND WASHER <A/T>

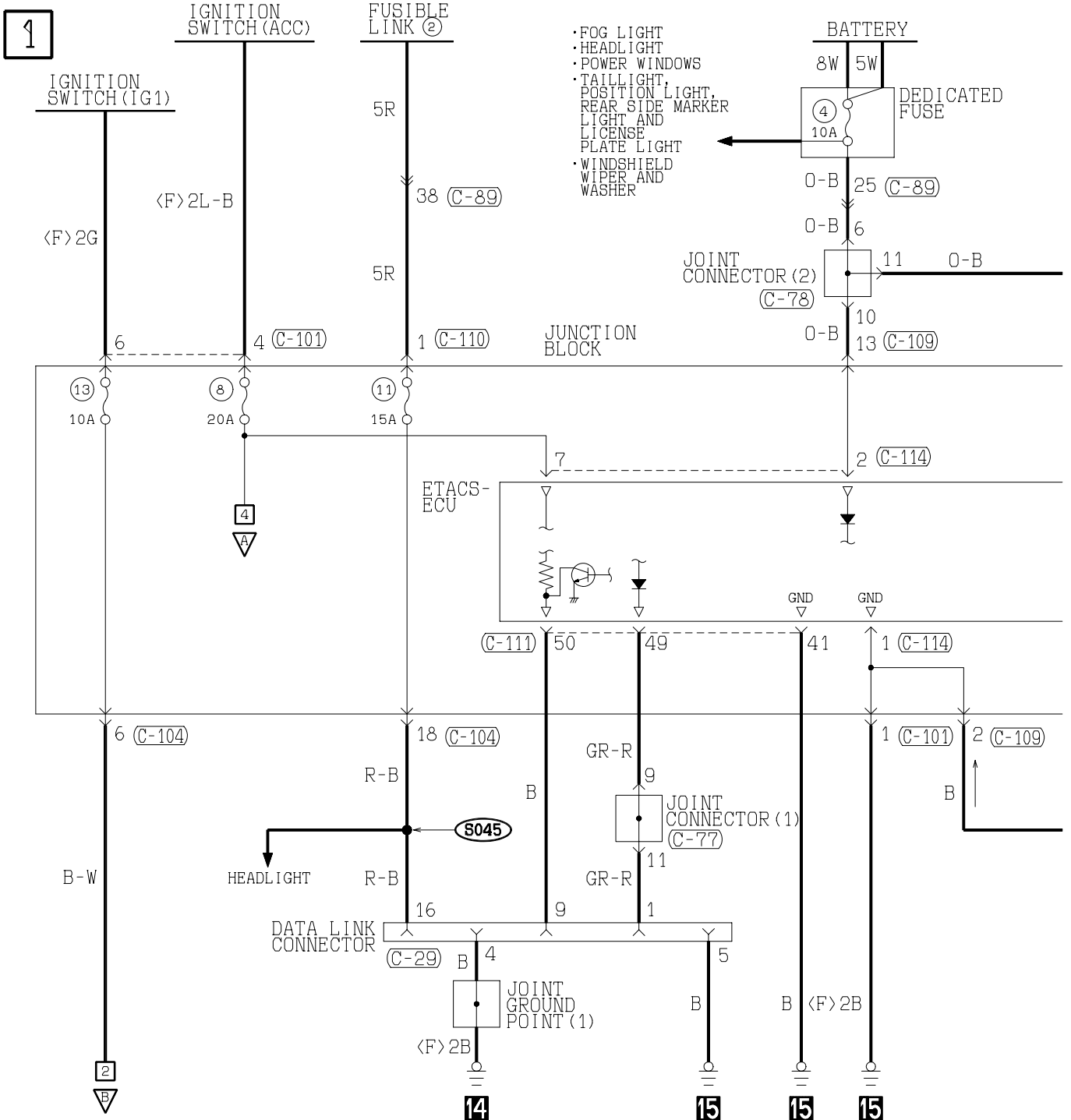

- FOG LIGHT
- HEADLIGHT
- POWER WINDOWS
- TAILLIGHT, POSITION LIGHT, REAR SIDE MARKER LIGHT AND LICENSE PLATE LIGHT
- WINDSHIELD WIPER AND WASHER

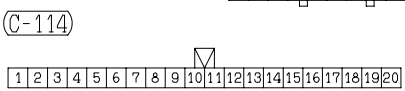
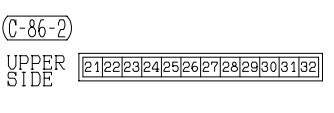
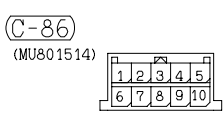
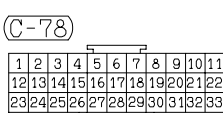
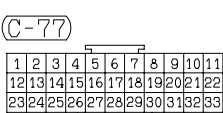
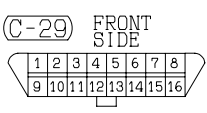

2

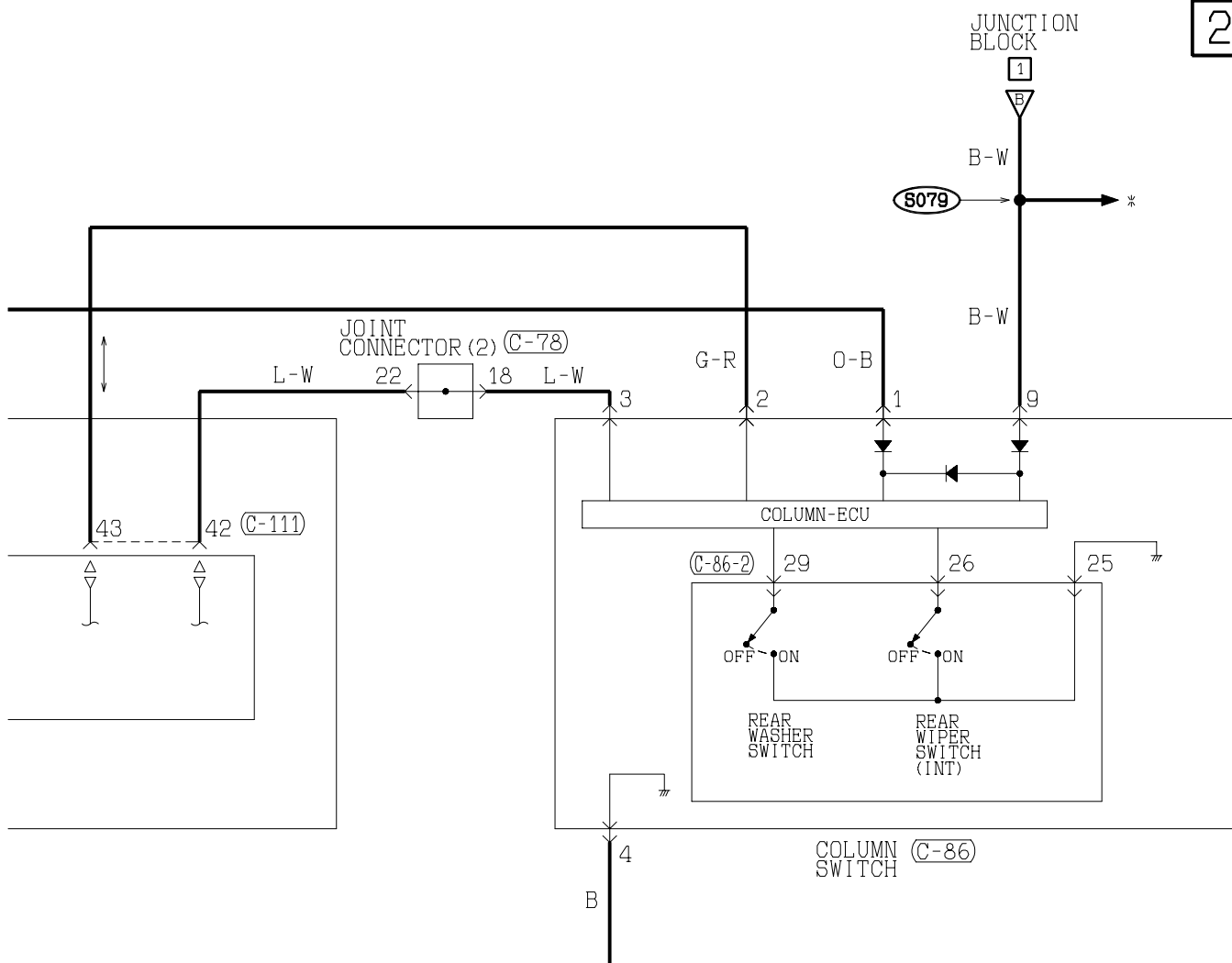

NOTE

- \*: ANTI-LOCK BRAKING SYSTEM
- AUTO-CRUISE CONTROL SYSTEM
- BRAKE WARNING LIGHT
- CHARGING SYSTEM
- FUEL WARNING LIGHT
- INVECS-II 4A/T
- METER AND GAUGE
- MFI SYSTEM
- MULTI CENTER DISPLAY
- OIL PRESSURE WARNING LIGHT
- SEAT BELT TONE ALARM
- SUPPLEMENTAL RESTRAINT SYSTEM

(C-89)

1	2	3	4	5	6	7	8	9	10	11	12	13
14	15	16	17	18	19	20	21	22	23	24	25	
26	27	28	29					30	31		38	
32	33	34		35				36	37			

(C-101)

MU801331

1	2
3	4

(C-104)

MU801457

1	2	3	4	5	6	7	8	9
10	11	12	13	14	15	16	17	18

(C-109)

1	2	3	4	M	5	6	7	8
9	10	11	12	13	14	15	16	17

(C-110)

1
---

(C-111)

(MU801584)

41	42	43	44	45	46	47	48
49	50	51	52	53	54	55	56

WIRE COLOR CODE  
 B : BLACK      LG : LIGHT GREEN      G : GREEN      L : BLUE  
 BR : BROWN    O : ORANGE              GR : GRAY      R : RED  
 W : WHITE      SB : SKY BLUE            P : PINK        Y : YELLOW  
 V : VIOLET

H1S13M08AB

TSB Revision

REAR WIPER AND WASHER <A/T> (CONTINUED)

3

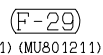
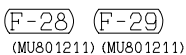
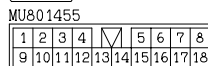
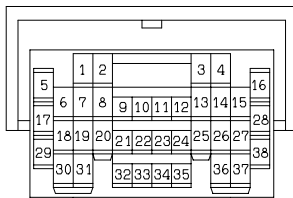
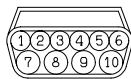
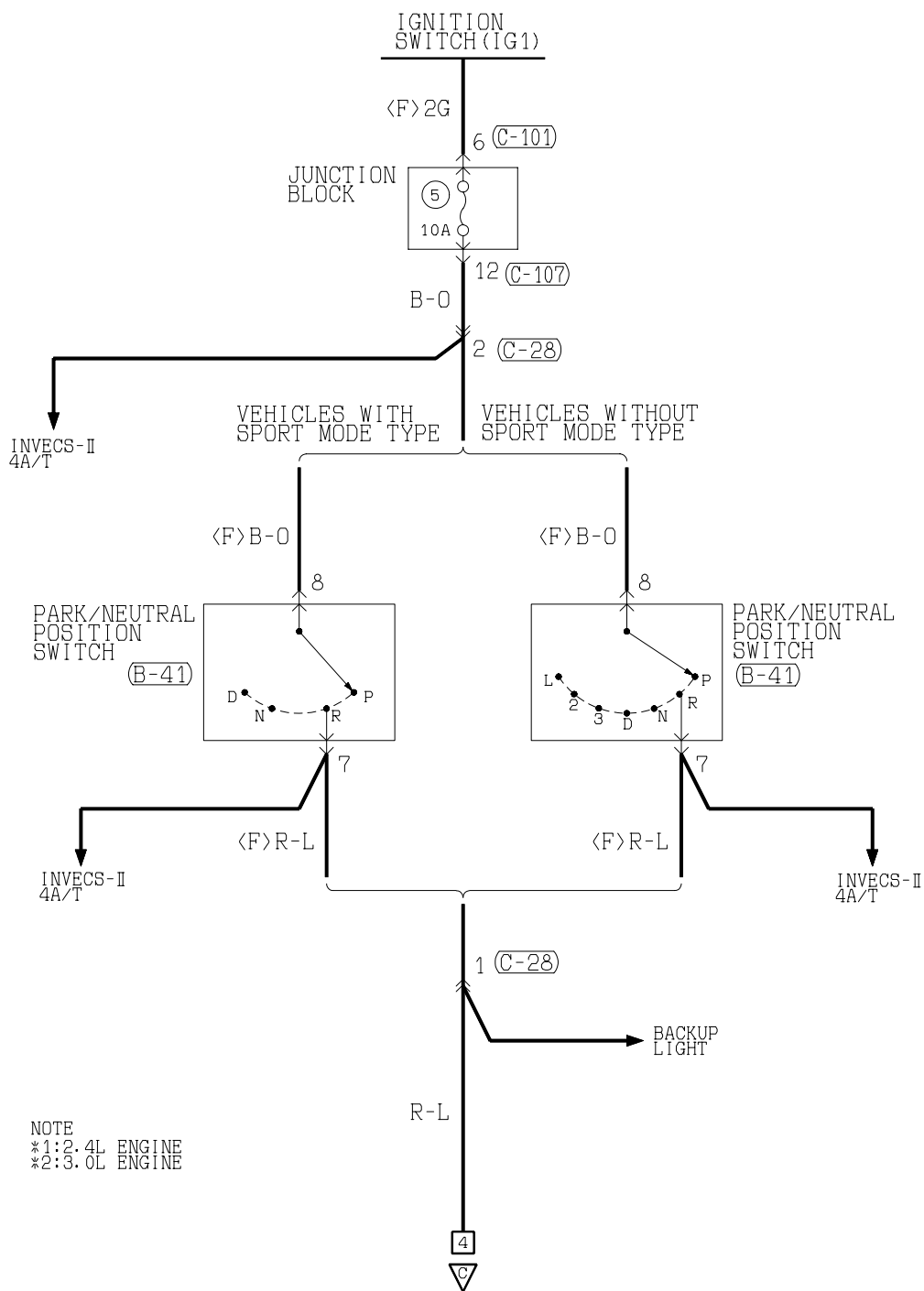

4

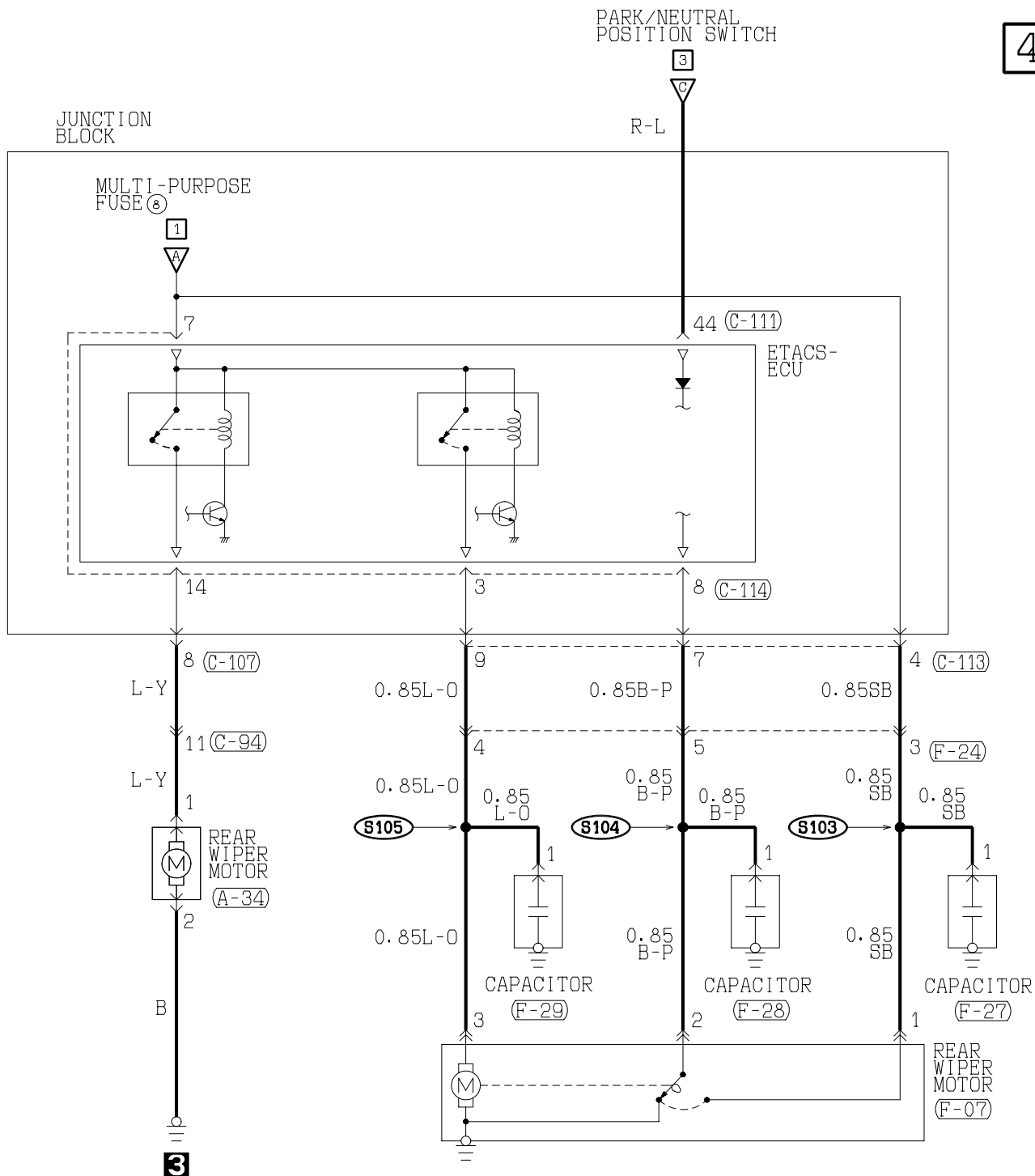

(C-107)

1	2	3	4	5	6	7	8	9	10
11	12	13	14	15	16	17	18	19	20
21	22								

(C-111) (MU801584)

41	42	43	44	45	46	47	48
49	50	51	52	53	54	55	56

(C-113)

1	2	3	4	5	6	7	8	9
10	11	12	13	14	15	16	17	18
19								

(C-114)

1	2	3	4	5	6	7	8	9	10	11	12	13	14	15	16	17	18	19	20
---	---	---	---	---	---	---	---	---	----	----	----	----	----	----	----	----	----	----	----

(F-07)

1	2	3
---	---	---

WIRE COLOR CODE  
 B : BLACK BR : BROWN G : GREEN GR : GRAY L : BLUE LG : LIGHT GREEN O : ORANGE  
 P : PINK R : RED SB : SKY BLUE V : VIOLET W : WHITE Y : YELLOW

H1S13M08BB

TSB Revision

# DEFOGGER <ECLIPSE>

1

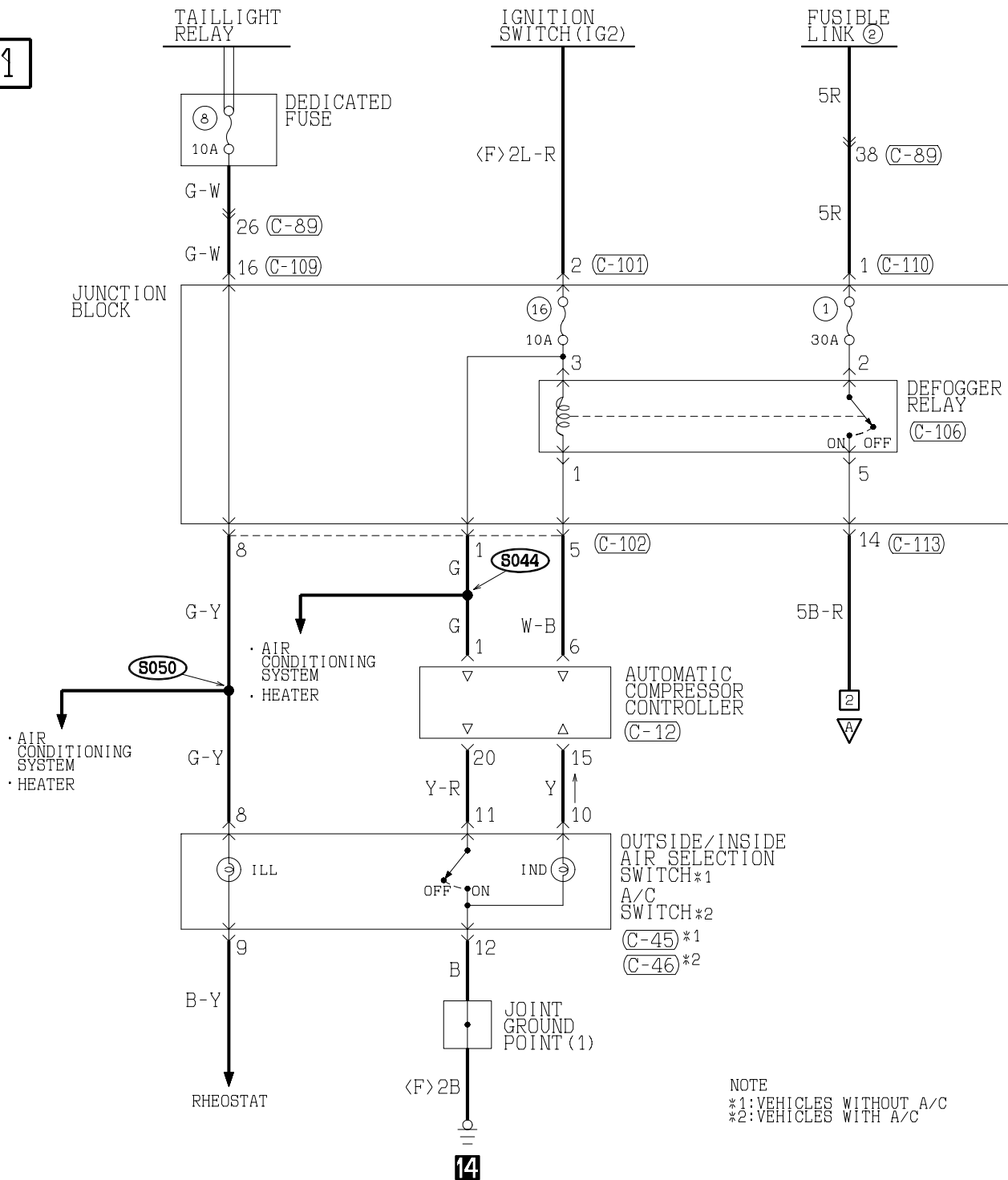

(C-12) (MU801585)

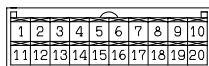

(C-45) (MU802098)

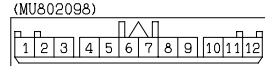

(C-46) (MU802098)

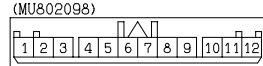

(C-89)

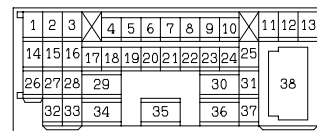

(C-101) MU801331



(F-24) MU801331



(F-26) (MU801211)





2

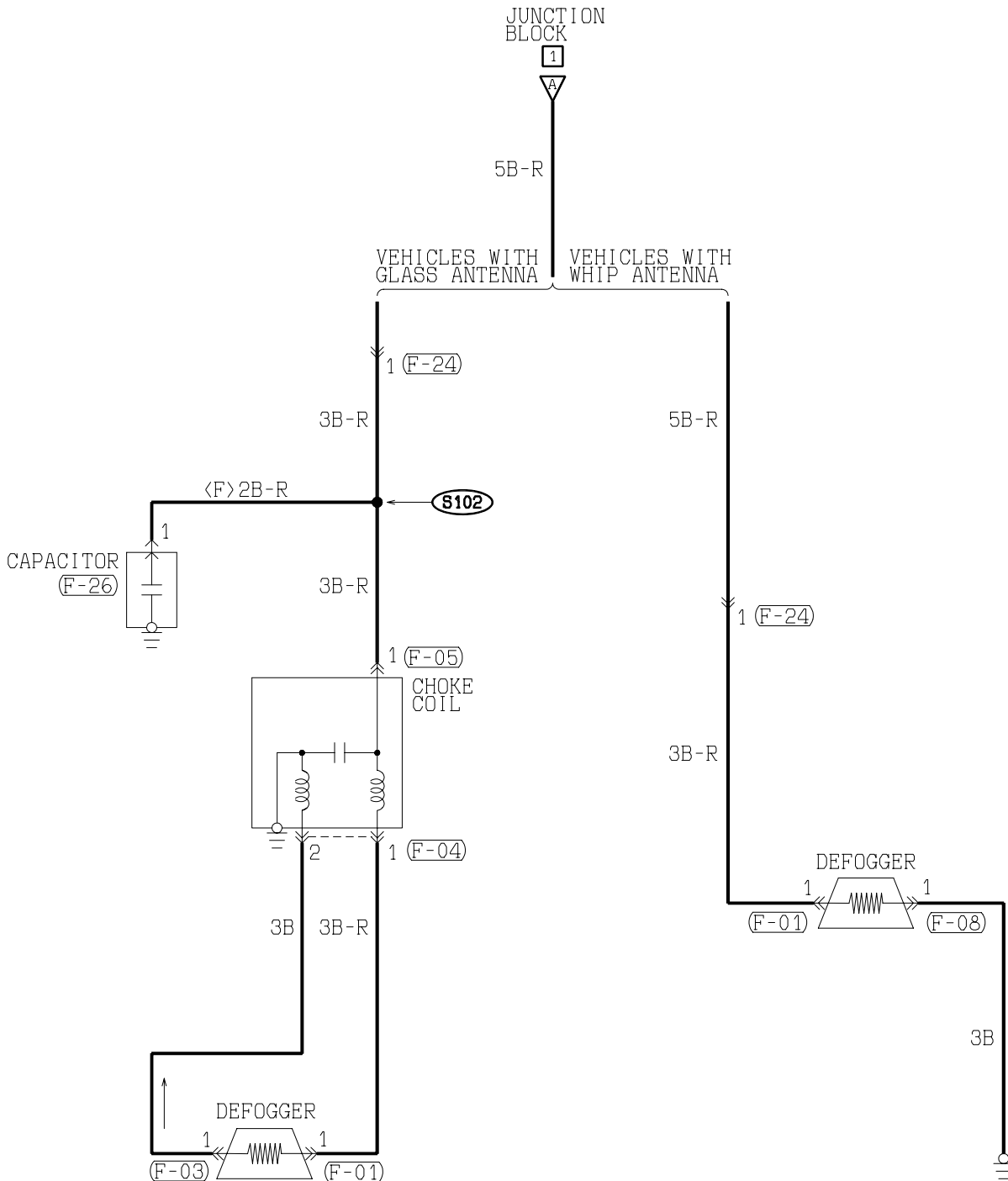

(C-102)

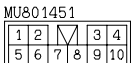

(C-106)



(C-109)

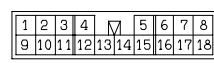

(C-110)



(C-113)

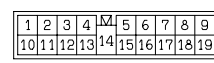

(F-01)



(F-03)



(F-04)



(F-05)



(F-08)



WIRE COLOR CODE

B : BLACK  
P : PINK

BR : BROWN  
R : RED

G : GREEN  
SB : SKY BLUE

GR : GRAY  
V : VIOLET

L : BLUE  
W : WHITE

LG : LIGHT GREEN  
Y : YELLOW

O : ORANGE

# DEFOGGER <ECLIPSE SPYDER>

1

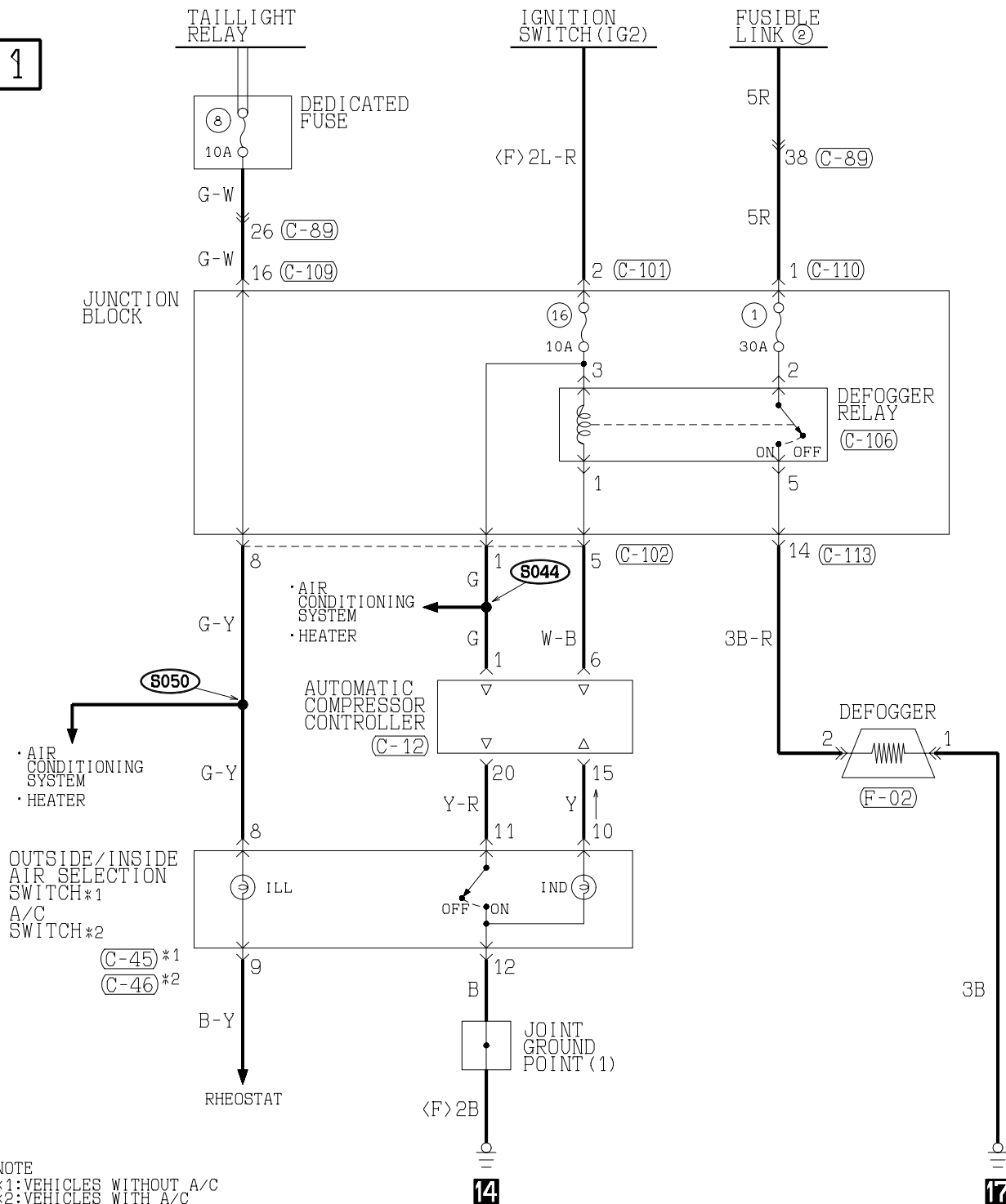

NOTE  
\*1: VEHICLES WITHOUT A/C  
\*2: VEHICLES WITH A/C

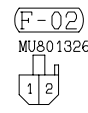
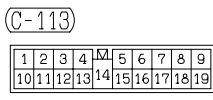
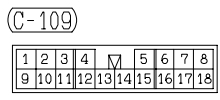
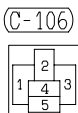
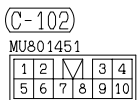
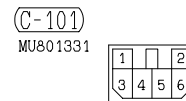
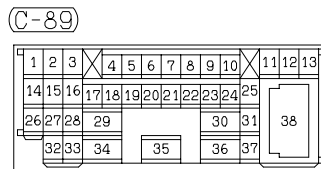
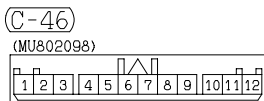
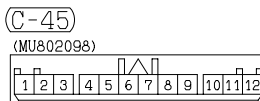
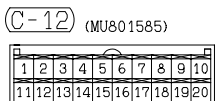

H1S13M10AA

TSB Revision

# REMOTE CONTROLLED MIRROR

M1901006500078

1

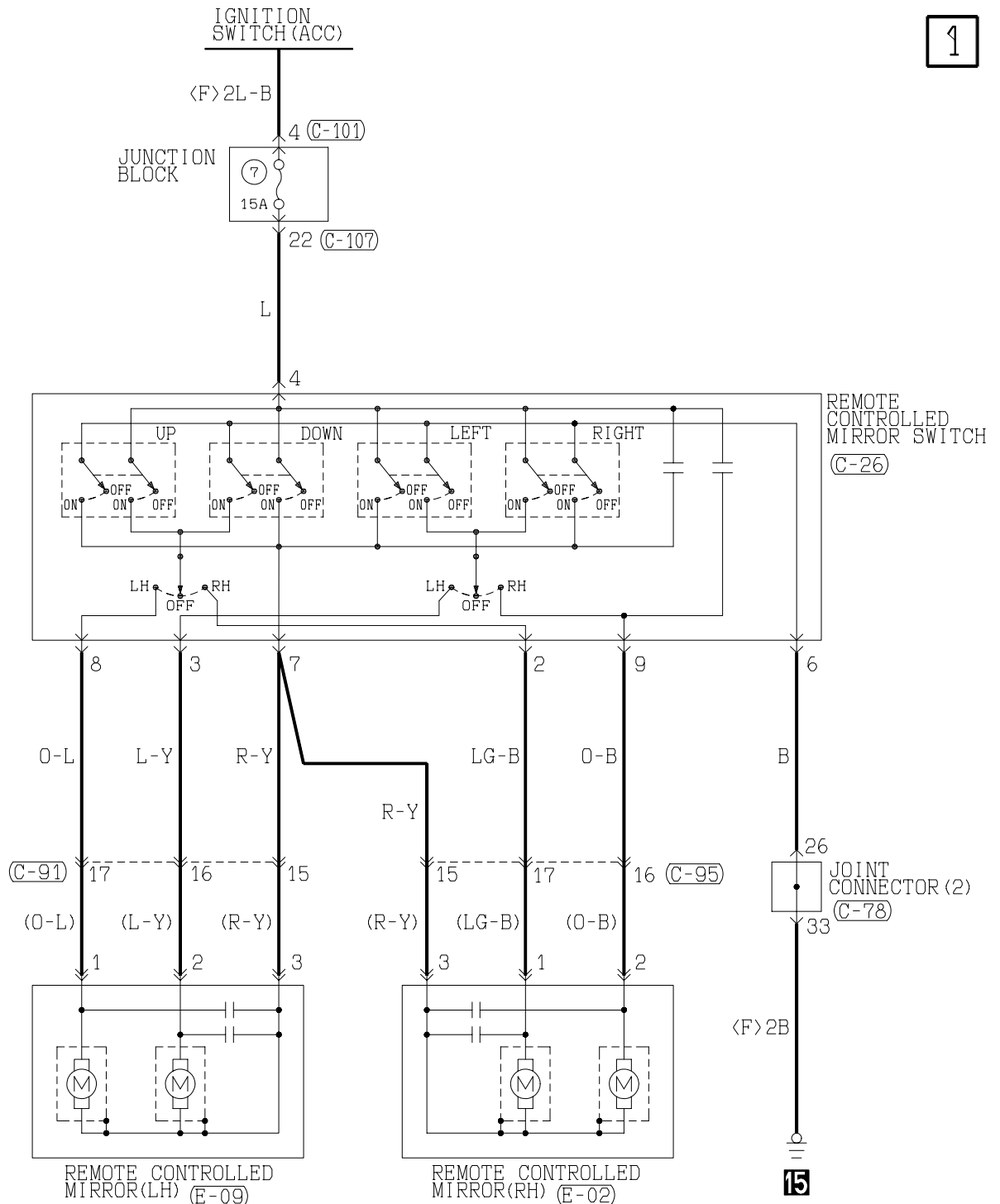

(C-26)

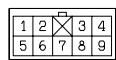

(C-78)

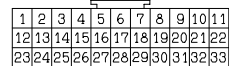

(C-91)

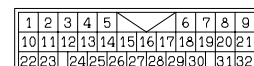

(C-95)

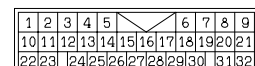

(C-101)  
MU801331



(C-107)

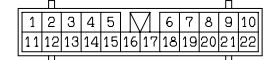

(E-02)



(E-09)



WIRE COLOR CODE

B : BLACK BR : BROWN G : GREEN GR : GRAY  
 L : BLUE LG : LIGHT GREEN P : PINK  
 R : RED SB : SKY BLUE V : VIOLET W : WHITE  
 Y : YELLOW

H1S13M11AA

TSB Revision

# AUDIO SYSTEM <VEHICLES WITHOUT AMPLIFIER>

M1901015600095

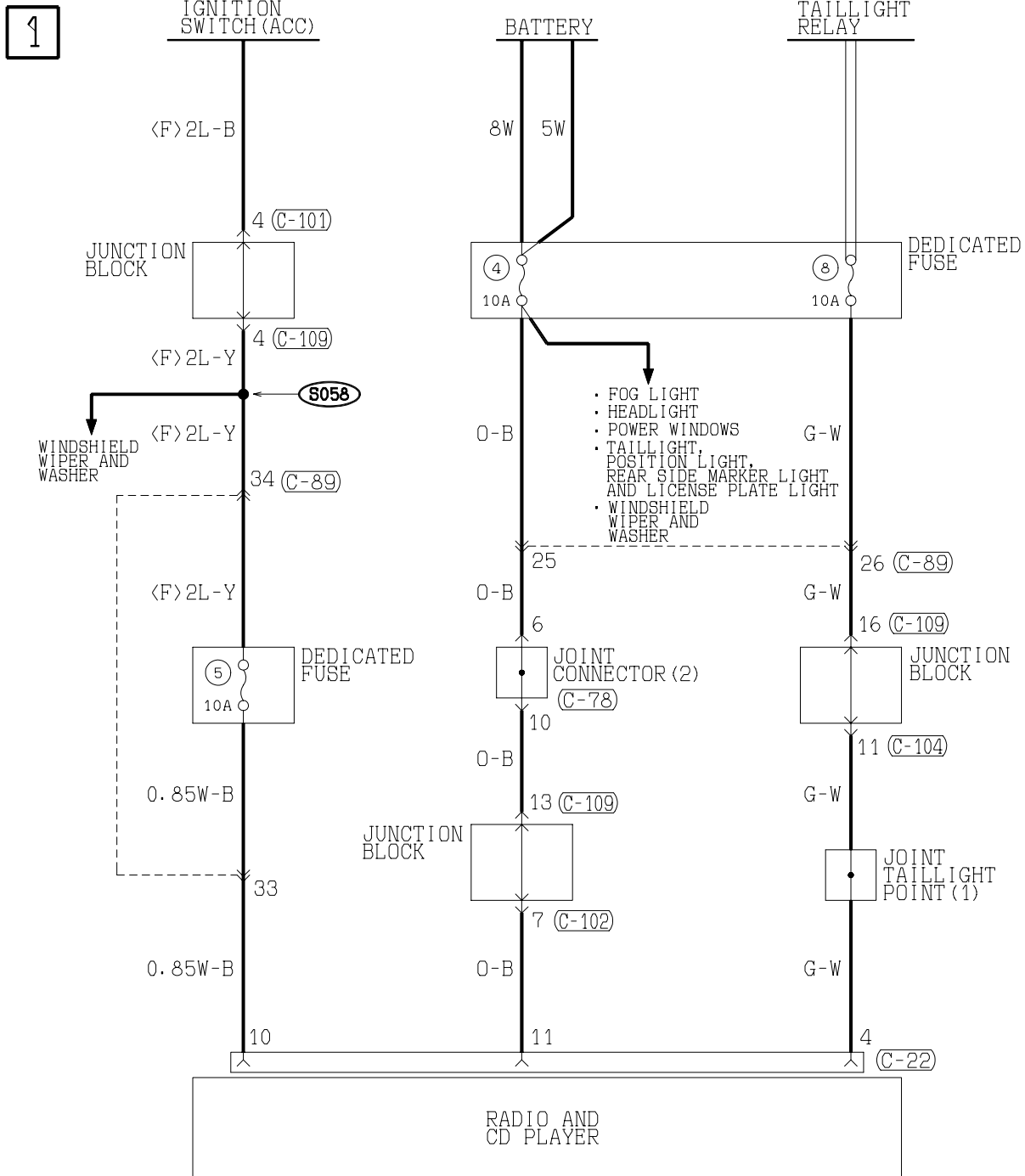

(C-22)

1	2	3	4	5	6
7	8	9	10	11	12
13	14	15	16	17	18
19	20	21	22	23	24
25	26	27	28	29	30
31	32	33			

(C-78)

1	2	3	4	5	6	7	8	9	10	11
12	13	14	15	16	17	18	19	20	21	22
23	24	25	26	27	28	29	30	31	32	33

(C-89)

1	2	3	4	5	6	7	8	9	10	11	12	13
14	15	16	17	18	19	20	21	22	23	24	25	26
27	28	29	30	31	32	33	34	35	36	37	38	39

(C-90)

1	2	3	4	5	6	7	8	9
10	11	12	13	14	15	16	17	18
19	20	21	22	23	24	25	26	27
28	29	30	31	32	33	34	35	36
37	38	39	40	41	42	43	44	45

(D-21)

1
2

(D-22)

1
2

(E-01)

1
2

(E-03)

1	2
---	---

(E-08)

1	2
---	---

(E-10)

1
2

H1S14M09AA

TSB Revision

2

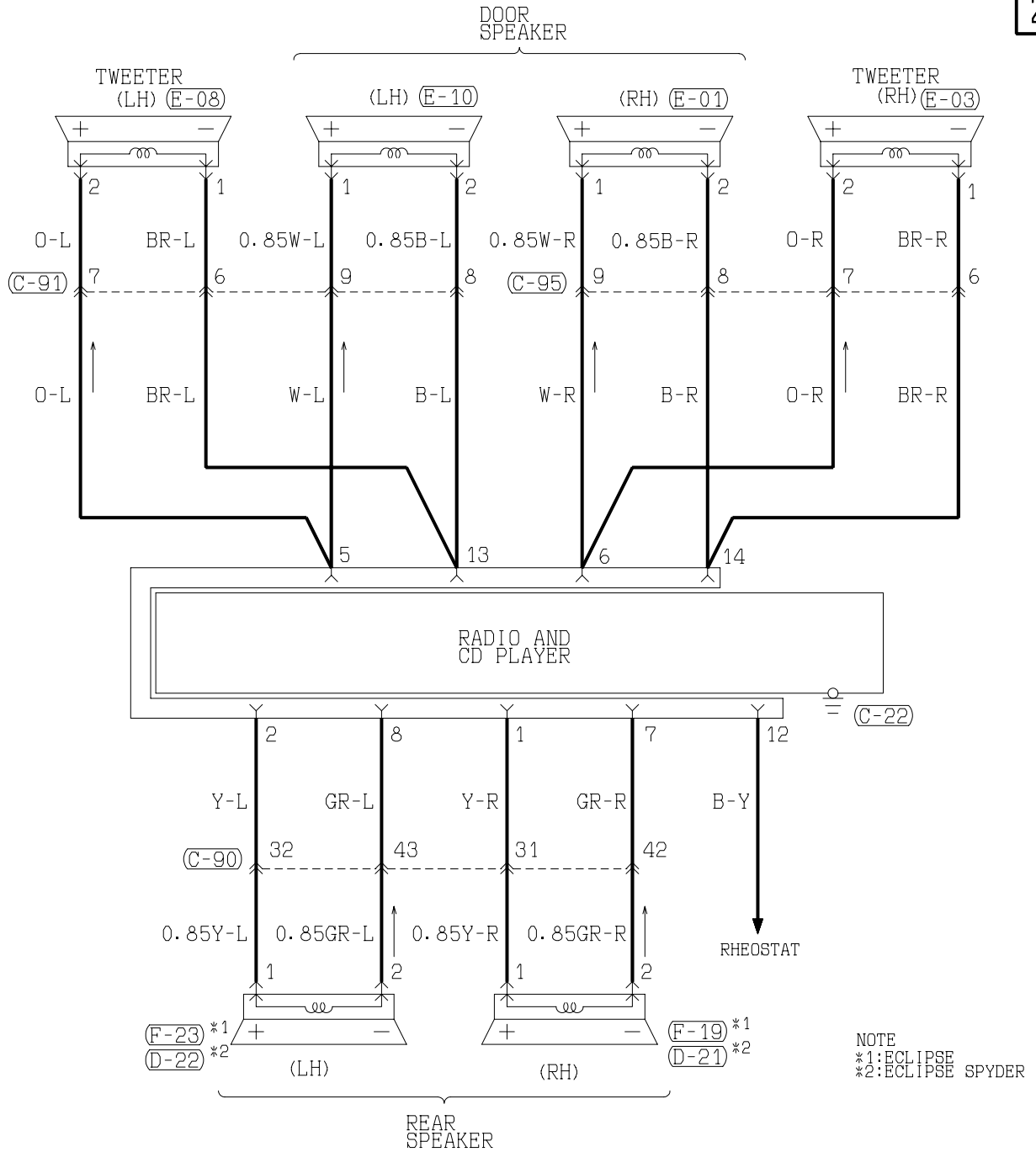

NOTE  
 \*1: ECLIPSE  
 \*2: ECLIPSE SPYDER

(C-91)

1	2	3	4	5	6	7	8	9
10	11	12	13	14	15	16	17	18
19	20	21	22	23	24	25	26	27
28	29	30	31	32				

(C-95)

1	2	3	4	5	6	7	8	9
10	11	12	13	14	15	16	17	18
19	20	21	22	23	24	25	26	27
28	29	30	31	32				

(C-101)  
 MU801331

1	2	3
4	5	6

(C-102)  
 MU801451

1	2	3	4
5	6	7	8
9	10		

(C-104)  
 MU801457

1	2	3	4	5	6	7	8	9
10	11	12	13	14	15	16	17	18
19	20	21	22	23	24	25	26	27
28	29	30	31	32				

(C-109)

1	2	3	4	5	6	7	8
9	10	11	12	13	14	15	16
17	18						

(F-19) (F-23)  
 MU801671 MU801671

1
2

WIRE COLOR CODE  
 B : BLACK BR: BROWN G : GREEN GR: GRAY  
 L : BLUE LG: LIGHT GREEN O : ORANGE P : PINK  
 R : RED SB: SKY BLUE V : VIOLET W : WHITE  
 Y : YELLOW

H1S14M09AB

**TSB Revision**

AUDIO SYSTEM <VEHICLES WITHOUT AMPLIFIER> (CONTINUED)

3

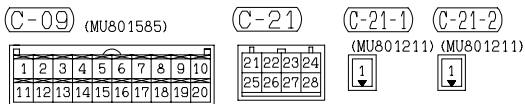
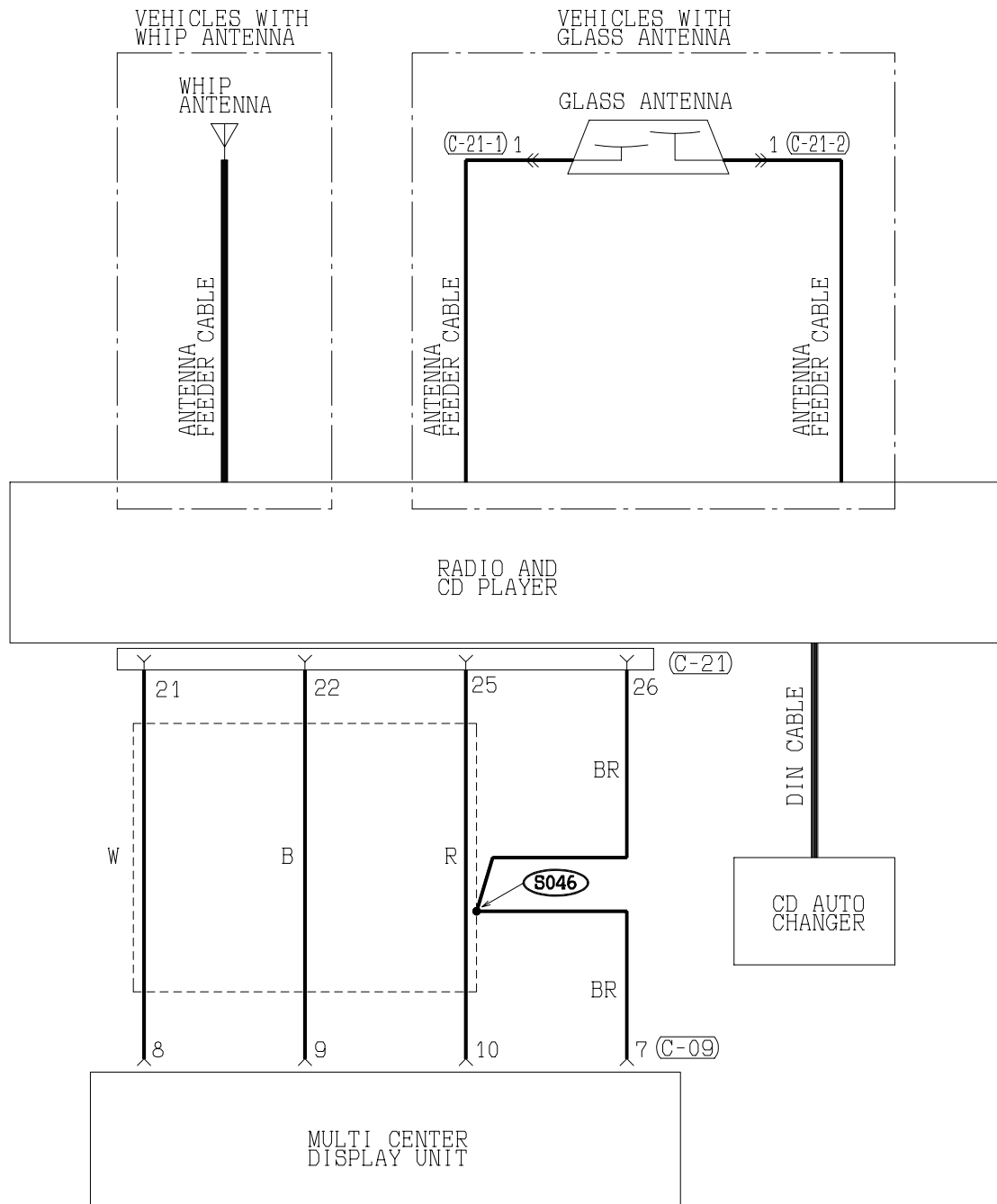

WIRE COLOR CODE  
 B : BLACK BR : BROWN G : GREEN GR : GRAY L : BLUE LG : LIGHT GREEN O : ORANGE  
 P : PINK R : RED SB : SKY BLUE V : VIOLET W : WHITE Y : YELLOW

TSB Revision

NOTES

TSB Revision

AUDIO SYSTEM <VEHICLES WITH AMPLIFIER>

M1901015600114

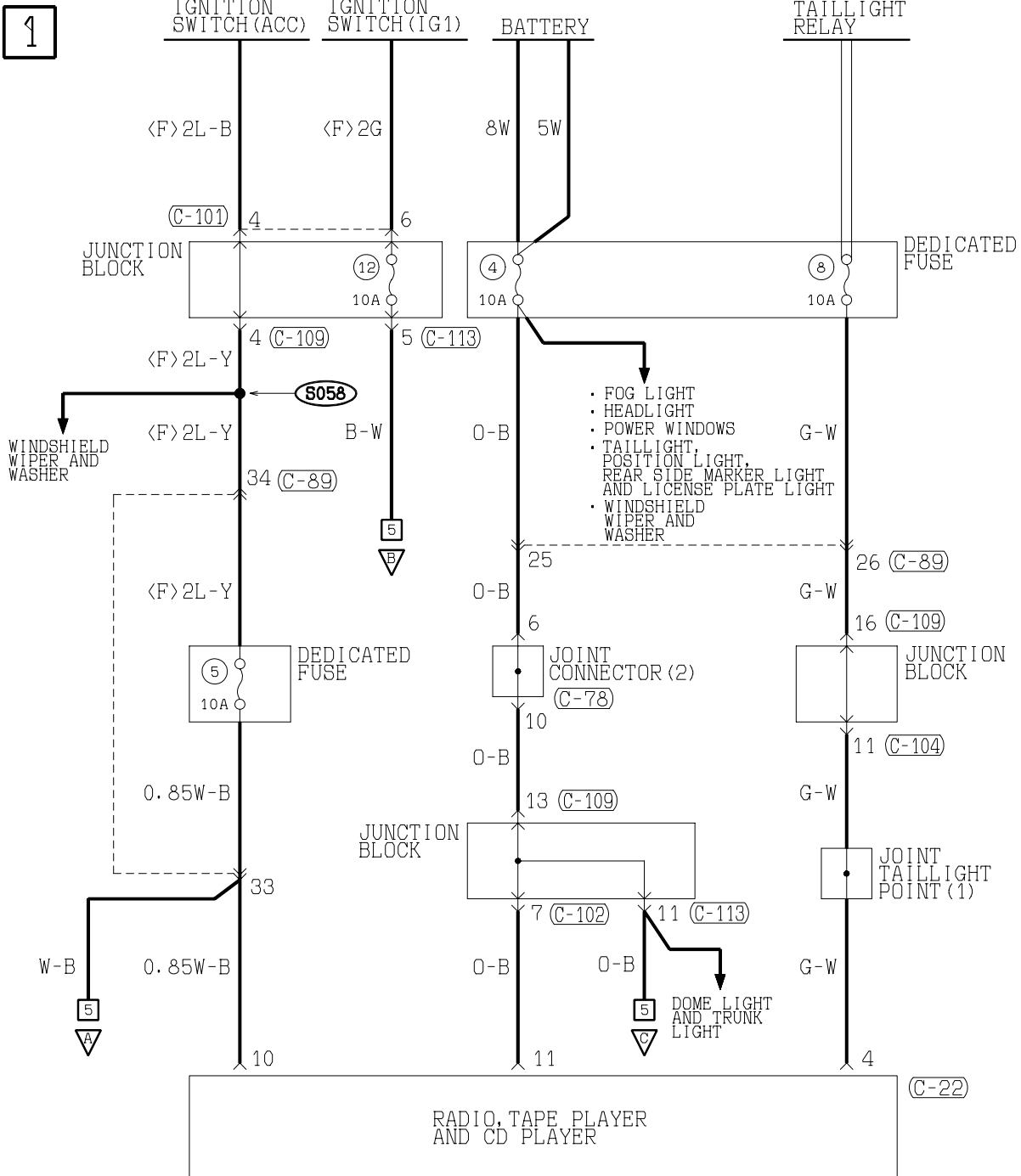

(C-09) (MU801585)

1	2	3	4	5	6	7	8	9	10
11	12	13	14	15	16	17	18	19	20

(C-21)

21	22	23	24
25	26	27	28

(C-21-1) (MU801211)

1
---

(C-21-2) (MU801211)

1
---

(C-22) MU801453

1	2	3	4	5	6
7	8	9	10	11	12
13	14	15	16	17	18
19	20	21	22	23	24
25	26	27	28	29	30
31	32	33			

(C-78)

1	2	3	4	5	6	7	8	9	10	11
12	13	14	15	16	17	18	19	20	21	22
23	24	25	26	27	28	29	30	31	32	33

(C-89)

1	2	3	4	5	6	7	8	9	10	11	12	13
14	15	16	17	18	19	20	21	22	23	24	25	
26	27	28	29			30	31					
32	33	34		35		36	37					
											38	

H1S14M10AA

TSB Revision



2

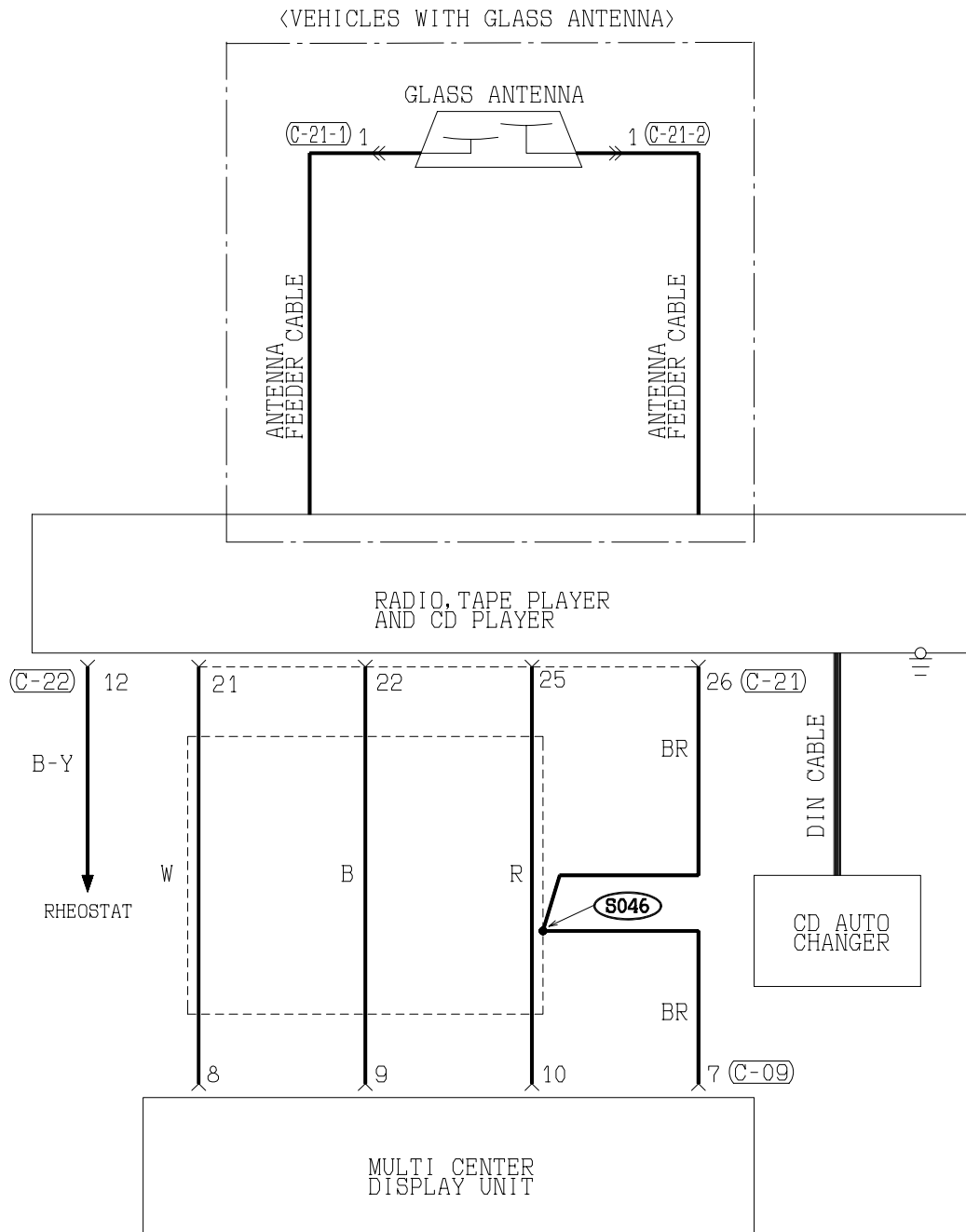

(C-101)  
MU801331

1	2
3	4

(C-102)  
MU801451

1	2	3	4
5	6	7	8
9	10		

(C-104)  
MU801457

1	2	3	4	5	6	7	8	9
10	11	12	13	14	15	16	17	18
19	20							

(C-109)

1	2	3	4	5	6	7	8
9	10	11	12	13	14	15	16
17	18						

(C-113)

1	2	3	4	5	6	7	8	9
10	11	12	13	14	15	16	17	18
19								

WIRE COLOR CODE

B : BLACK      BR : BROWN      G : GREEN      GR : GRAY      L : BLUE      LG : LIGHT GREEN      O : ORANGE  
P : PINK      R : RED      SB : SKY BLUE      V : VIOLET      W : WHITE      Y : YELLOW

H1S14M10AB

TSB Revision

AUDIO SYSTEM <VEHICLES WITH AMPLIFIER> (CONTINUED)

3

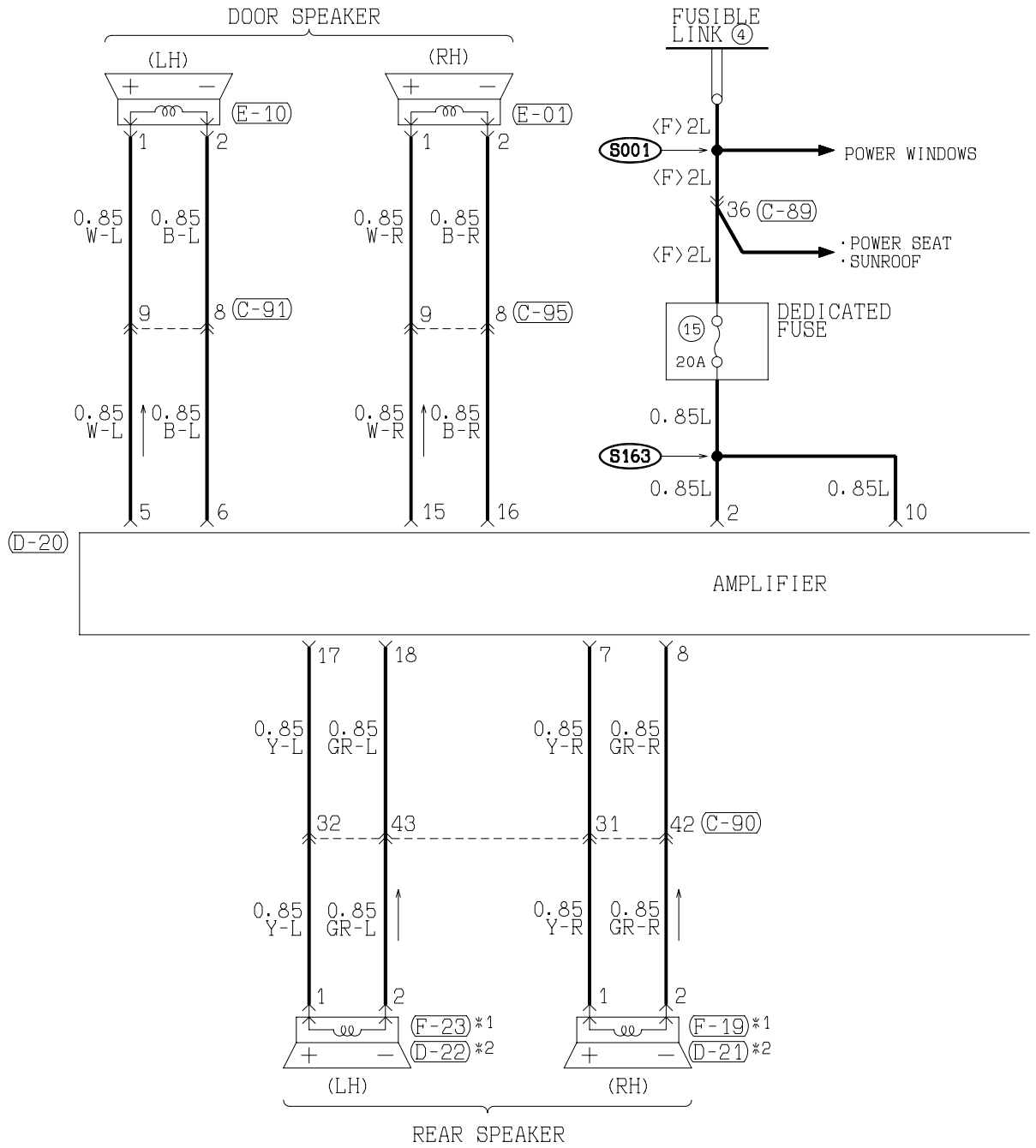

(C-08) MU801442

1	2	3	4	5	6	7	8	9	10	11	12	13
14	15	16	17	18	19	20	21	22	23	24	25	38
26	27	28	29	30	31	32	33	34	35	36	37	

(C-89)

1	2	3	4	5	6	7	8	9	10	11	12	13
14	15	16	17	18	19	20	21	22	23	24	25	38
26	27	28	29	30	31	32	33	34	35	36	37	

(C-90)

1	2	3	4	5	6	7	8	9			
10	11	12	13	14	15	16	17	18	19	20	21
22	23	24	25	26	27	28	29	30	31	32	33
34	35	36	37	38	39	40	41	42	43		

(C-91)

1	2	3	4	5	6	7	8	9			
10	11	12	13	14	15	16	17	18	19	20	21
22	23	24	25	26	27	28	29	30	31	32	

(C-95)

1	2	3	4	5	6	7	8	9			
10	11	12	13	14	15	16	17	18	19	20	21
22	23	24	25	26	27	28	29	30	31	32	

4

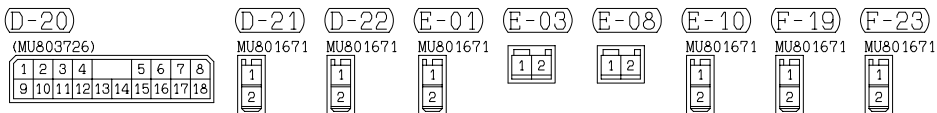
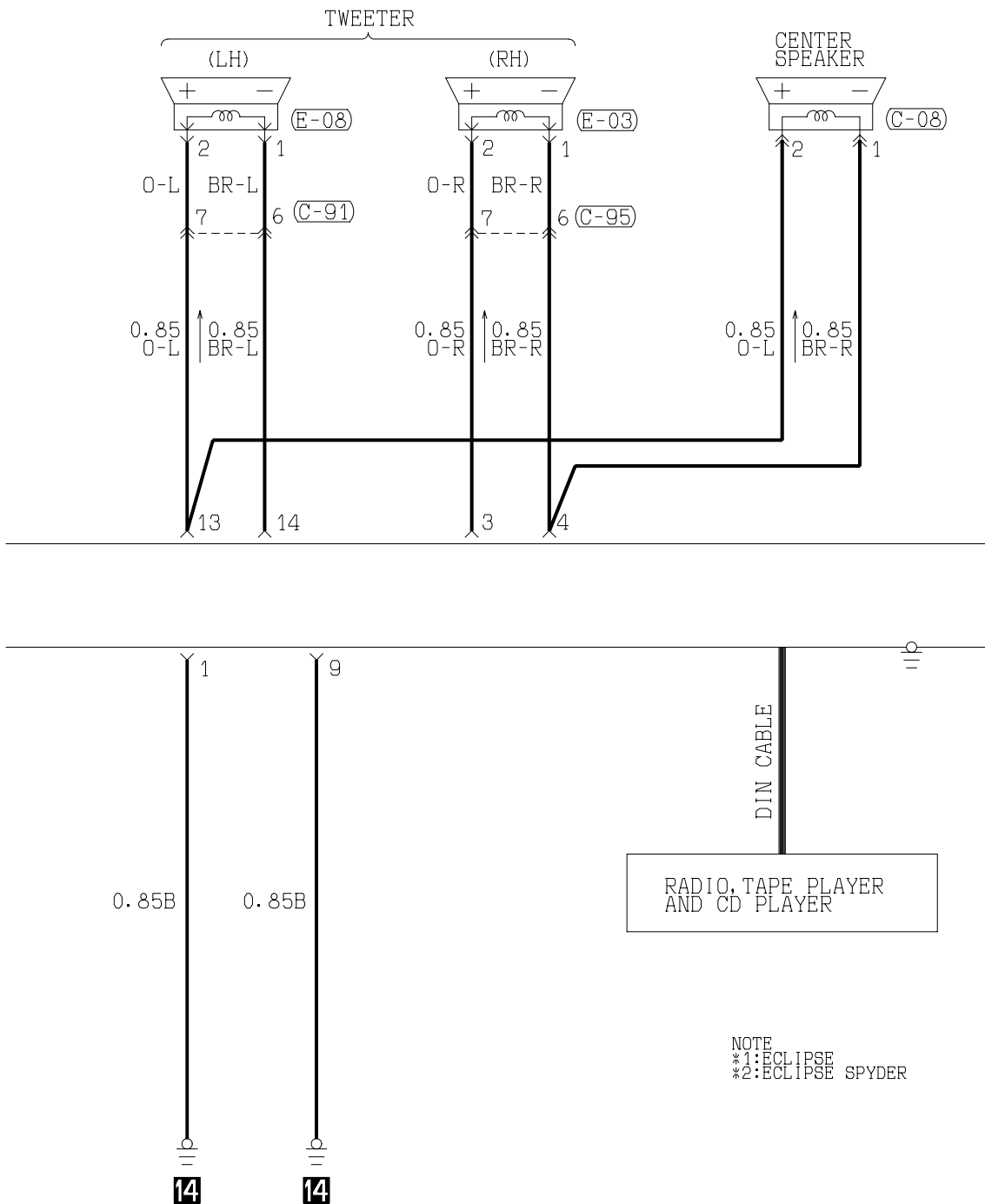

WIRE COLOR CODE  
 B : BLACK BR : BROWN G : GREEN GR : GRAY L : BLUE LG : LIGHT GREEN O : ORANGE  
 P : PINK R : RED SB : SKY BLUE V : VIOLET W : WHITE Y : YELLOW

H1S14M10BB

TSB Revision

AUDIO SYSTEM <VEHICLES WITH AMPLIFIER> (CONTINUED)

5

<VEHICLES WITH MOTOR ANTENNA>

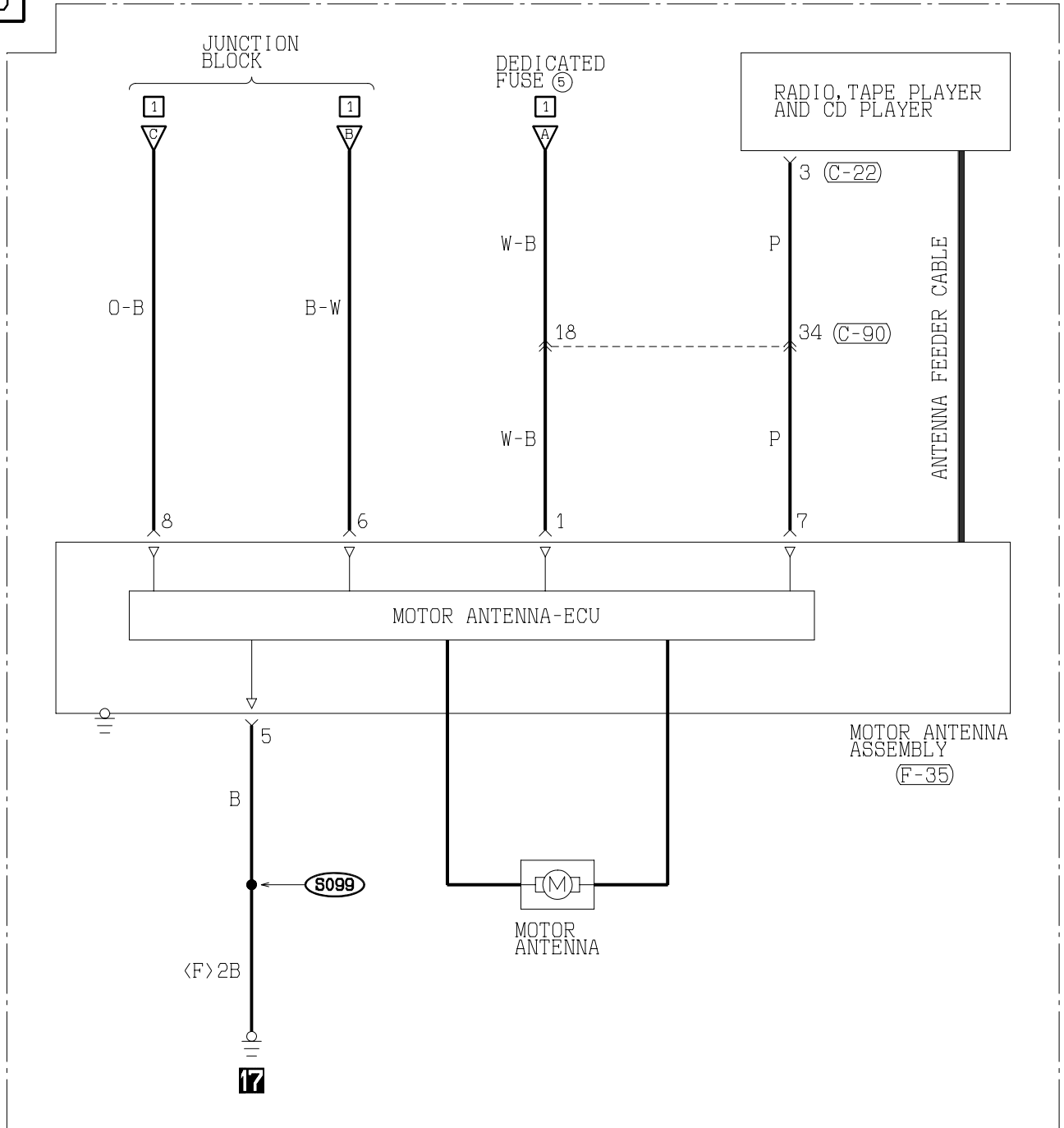

(C-22)

MU801453

1	2	3	4	5	6
7	8	9	10	11	12
13	14				

(C-90)

1	2	3	4	5	6	7	8	9
10	11	12	13	14	15	16	17	18
19	20	21						
22	23	24	25	26	27	28	29	30
31	32	33	34	35	36	37	38	39
40	41	42	43					

(F-35)

1	2	3	4
5	6	7	8

WIRE COLOR CODE  
 B : BLACK      LG : LIGHT GREEN      G : GREEN      L : BLUE  
 BR : BROWN    O : ORANGE            GR : GRAY      R : RED  
 W : WHITE      SB : SKY BLUE        P : PINK        Y : YELLOW  
 V : VIOLET

H1S14M10CA

TSB Revision

NOTES

TSB Revision

# MULTI CENTER DISPLAY

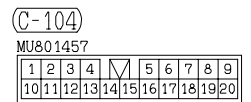
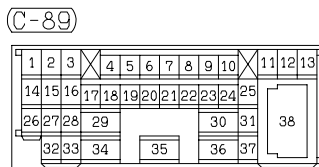
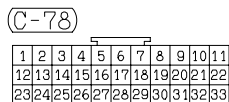
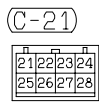
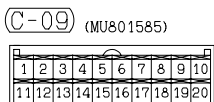
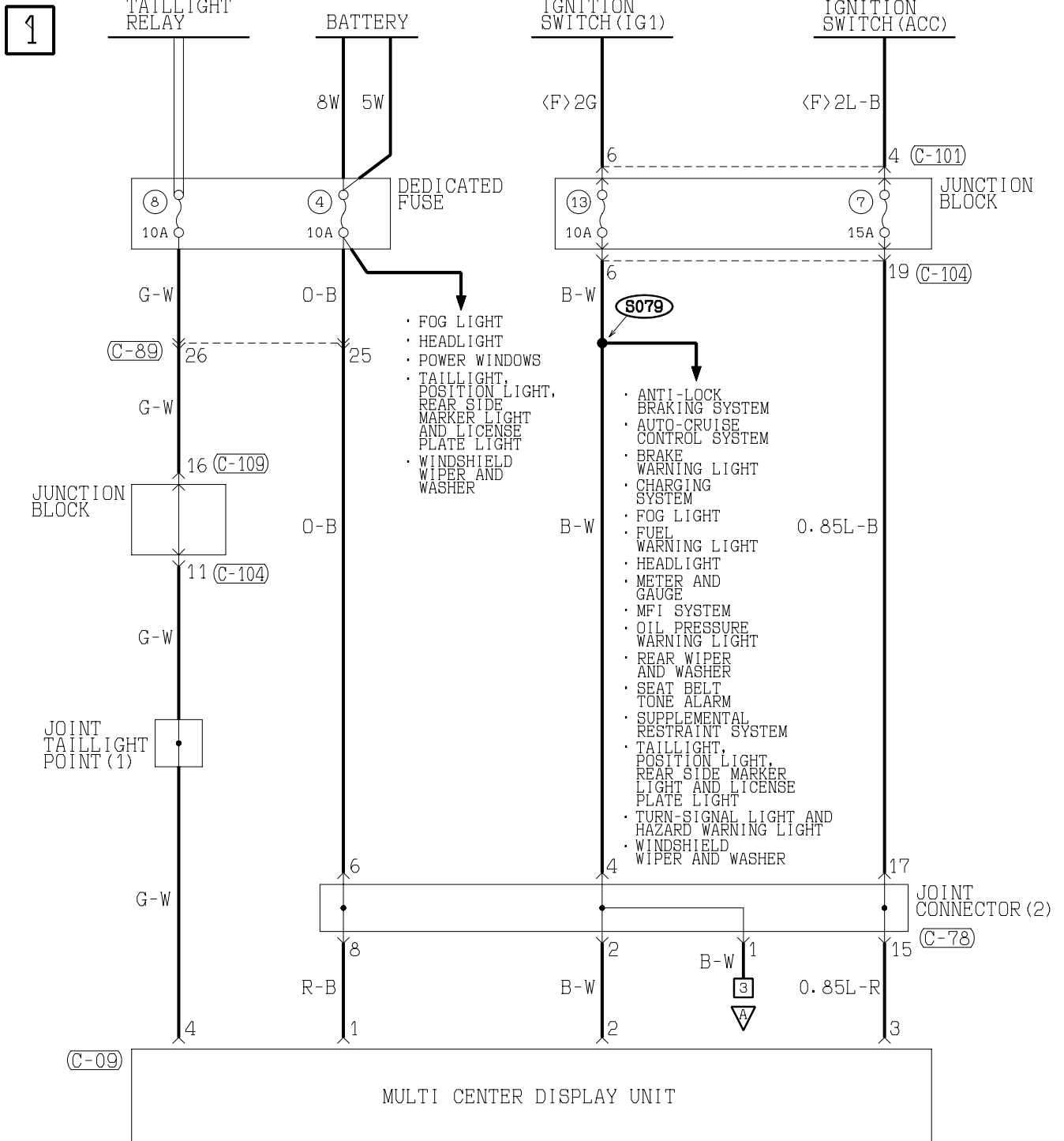

2

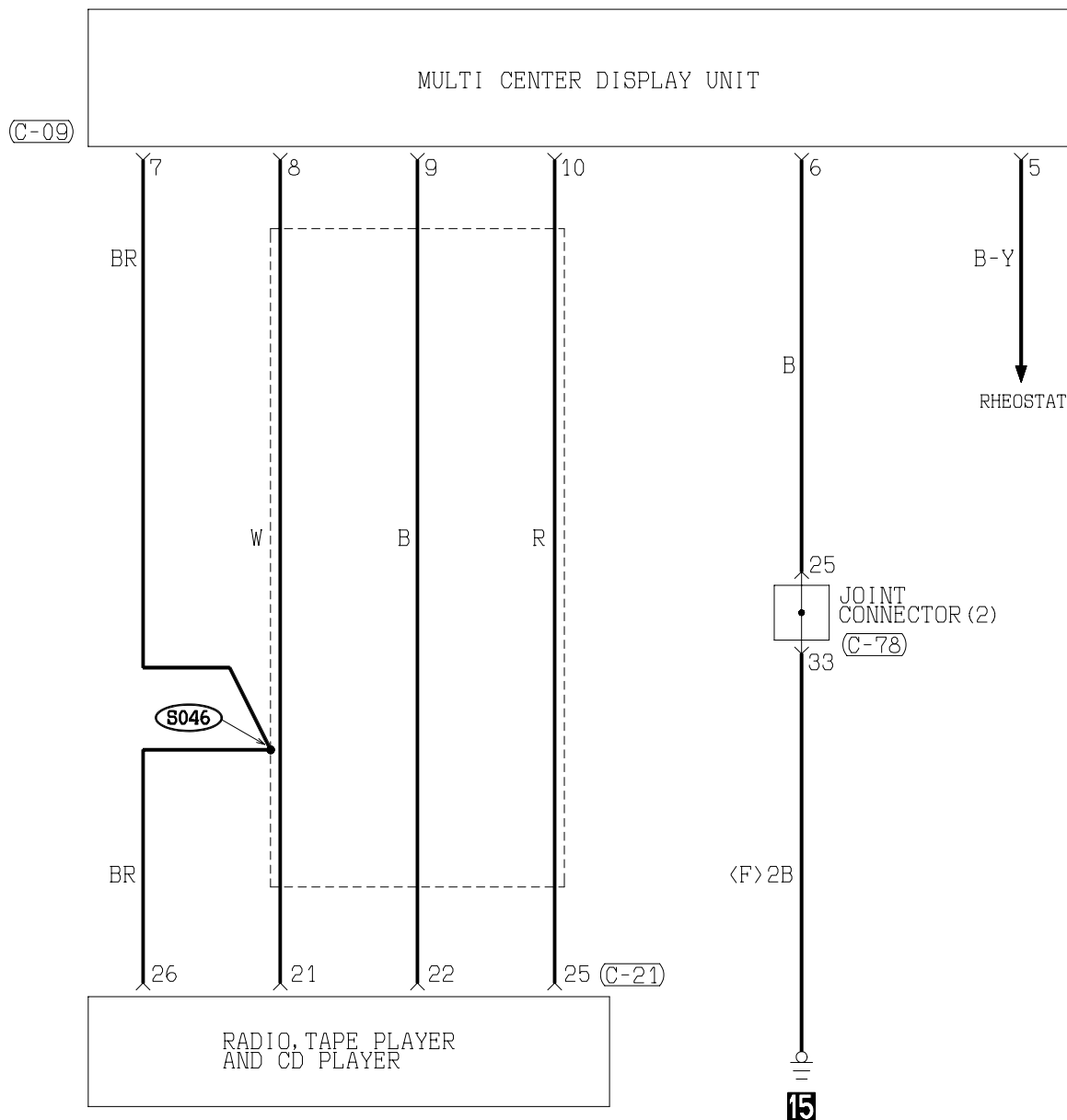

(C-109)

1	2	3	4	M	5	6	7	8	
9	10	11	12	13	14	15	16	17	18

WIRE COLOR CODE  
 B : BLACK BR : BROWN G : GREEN GR : GRAY L : BLUE LG : LIGHT GREEN O : ORANGE  
 P : PINK R : RED SB : SKY BLUE V : VIOLET W : WHITE Y : YELLOW

H1S14M11AB

TSB Revision

MULTI CENTER DISPLAY (CONTINUED)

3

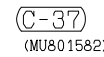
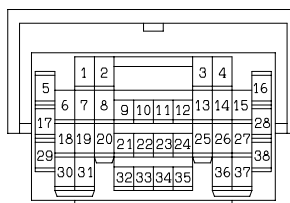
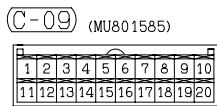
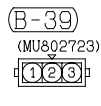
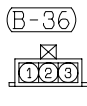
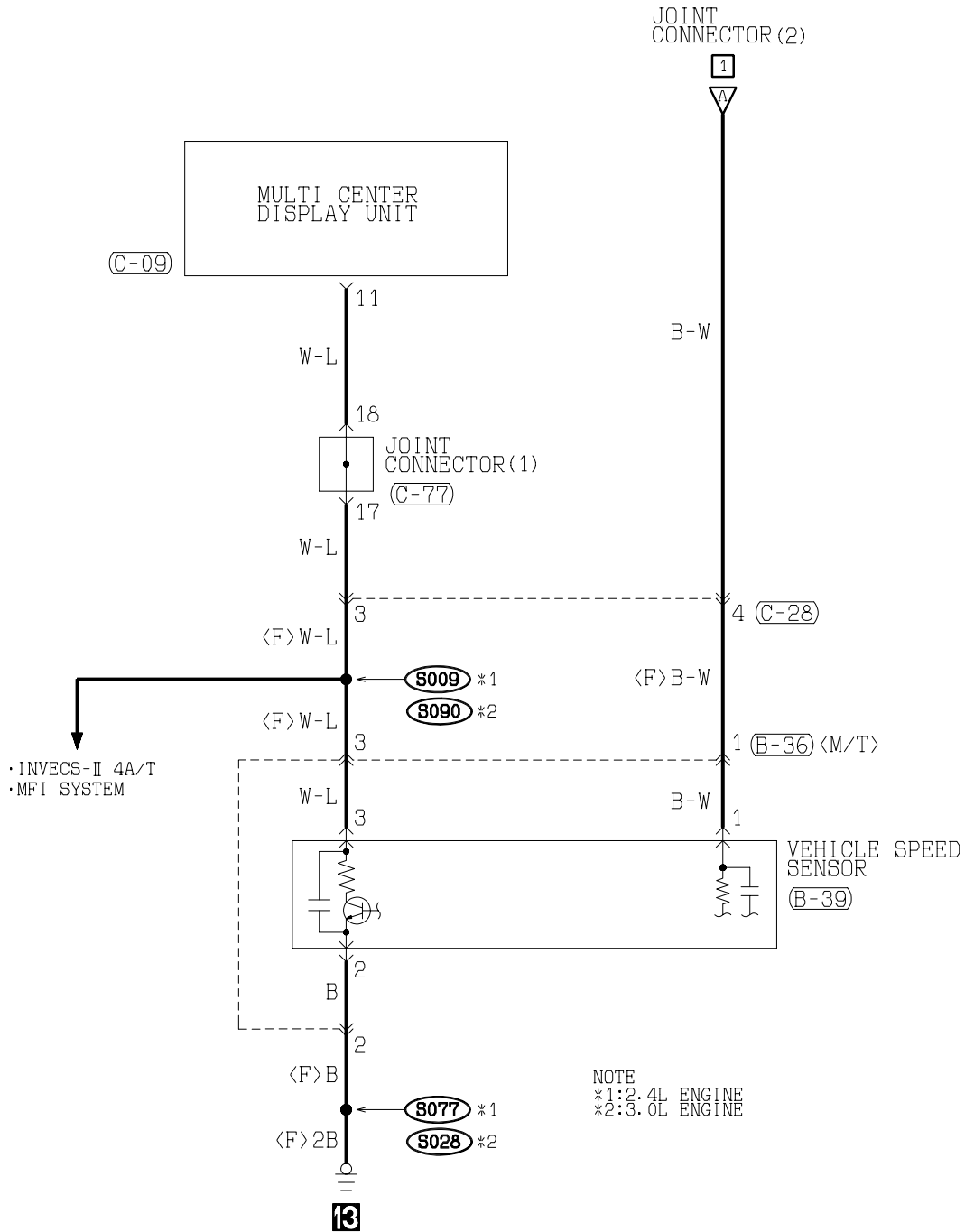

TSB Revision



<VEHICLES WITH COMPASS>

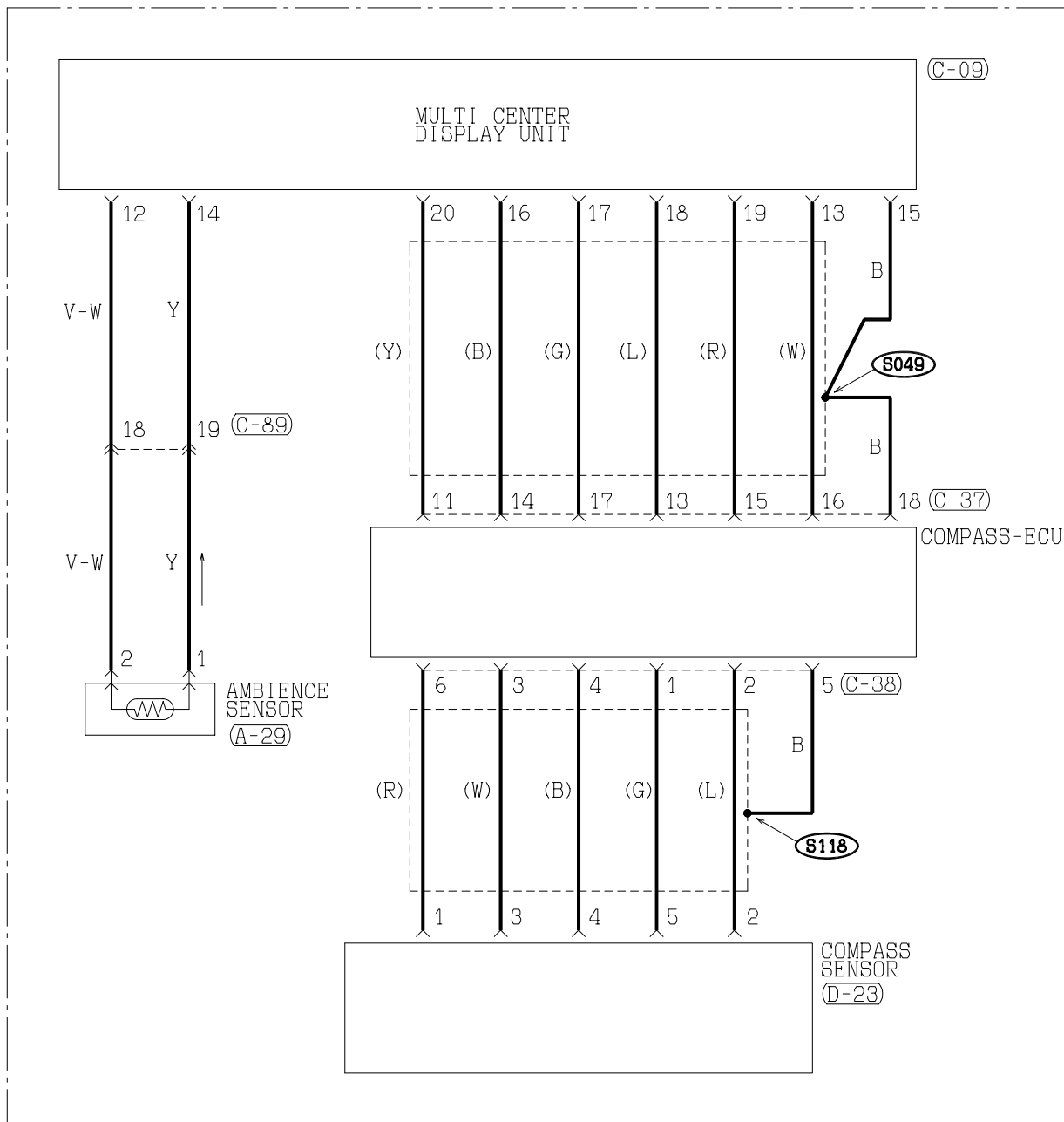

(C-77)

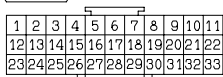

(C-89)

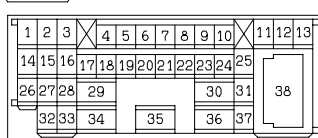

(D-23)

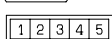

WIRE COLOR CODE

B : BLACK LG: LIGHT GREEN  
BR: BROWN O : ORANGE  
W : WHITE SB: SKY BLUE  
V : VIOLET

G : GREEN  
GR: GRAY  
P : PINK

L : BLUE  
R : RED  
Y : YELLOW

H1S14M11BB

TSB Revision

# CIGARETTE LIGHTER

1

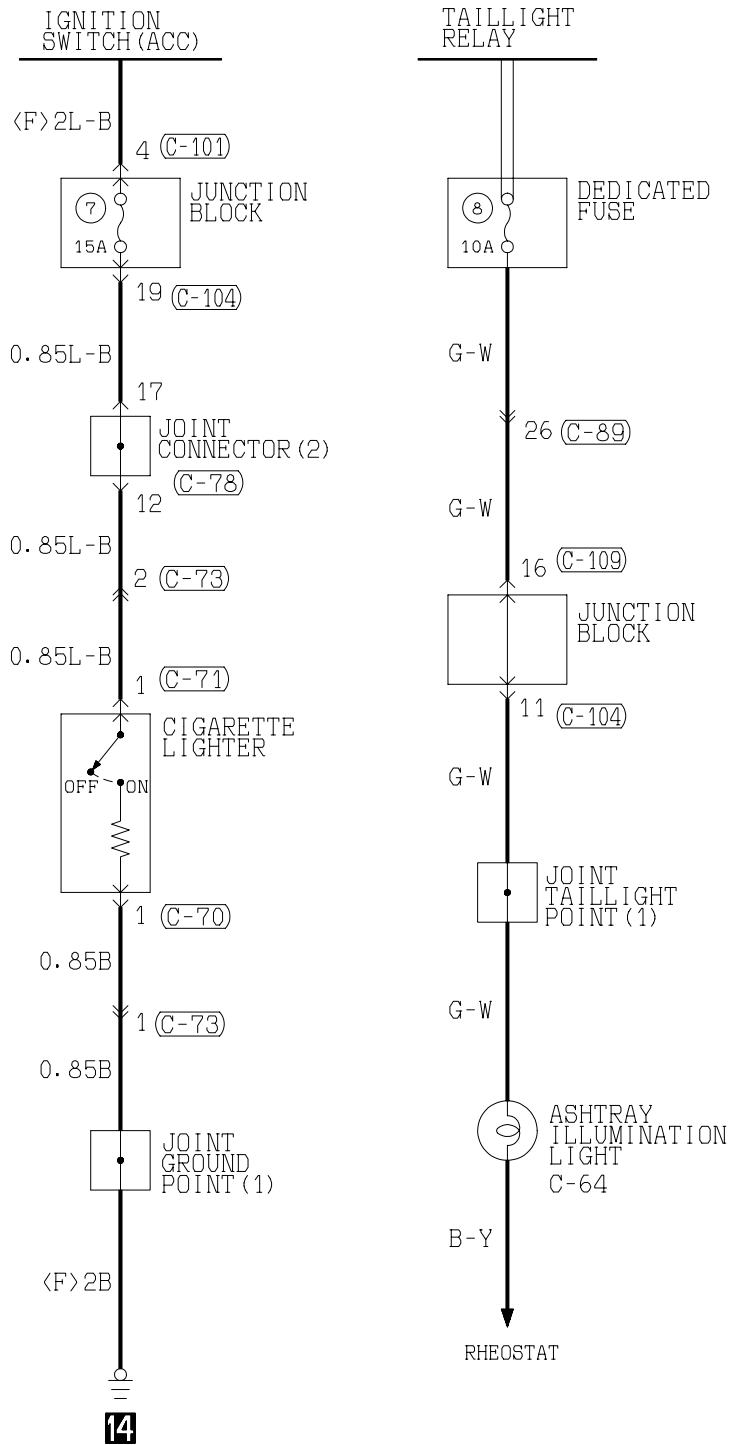

(C-70) (MU801211)

1
---

(C-71)

1
---

(C-73) MU801443

1	2	3
1	2	3

(C-78)

1	2	3	4	5	6	7	8	9	10	11
12	13	14	15	16	17	18	19	20	21	22
23	24	25	26	27	28	29	30	31	32	33

(C-89)

1	2	3	4	5	6	7	8	9	10	11	12	13
14	15	16	17	18	19	20	21	22	23	24	25	26
27	28	29	30	31	32	33	34	35	36	37	38	39

(C-101) MU801331

1	2
---	---

1	2
3	4
5	6

(C-104) MU801457

1	2	3	4	5	6	7	8	9
10	11	12	13	14	15	16	17	18
19	20							

(C-109)

1	2	3	4	5	6	7	8
9	10	11	12	13	14	15	16
17	18						

TSB Revision

# ACCESSORY SOCKET

M1901007900079

1

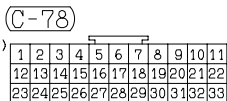
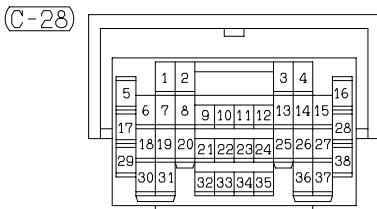
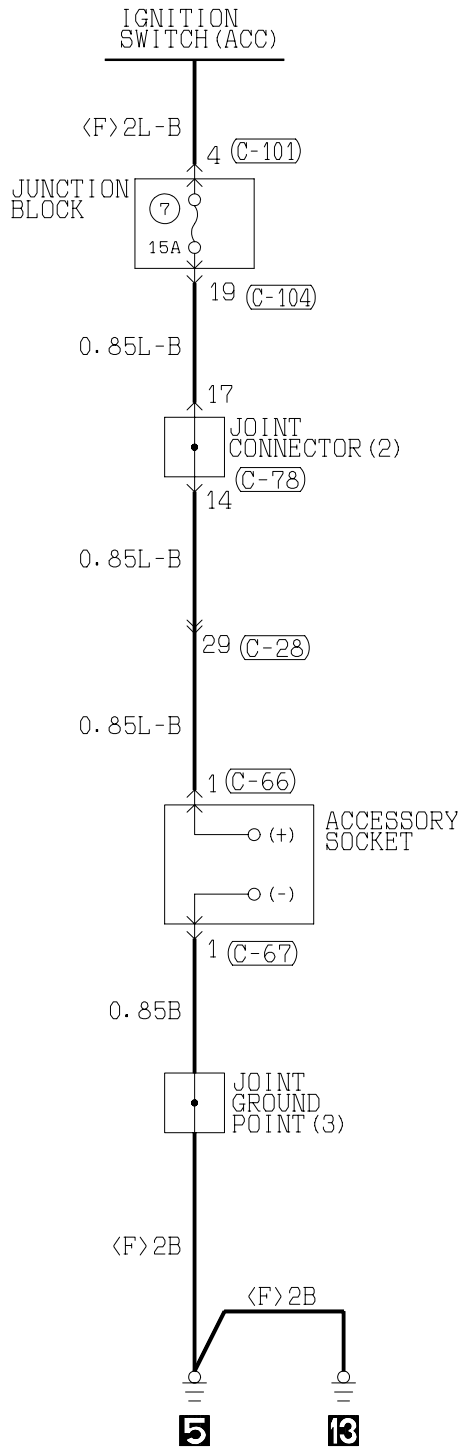

WIRE COLOR CODE

B : BLACK  
L : BLUE  
R : RED  
Y : YELLOW  
BR : BROWN  
LG : LIGHT GREEN  
SB : SKY BLUE

G : GREEN  
O : ORANGE  
V : VIOLET

GR : GRAY  
P : PINK  
W : WHITE

H1S14M13AA

TSB Revision

**AUTO-CRUISE CONTROL SYSTEM <2.4L ENGINE-M/T>**

M1901009300103

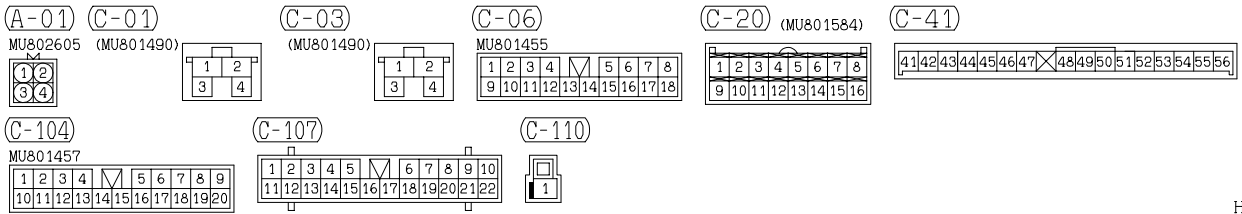
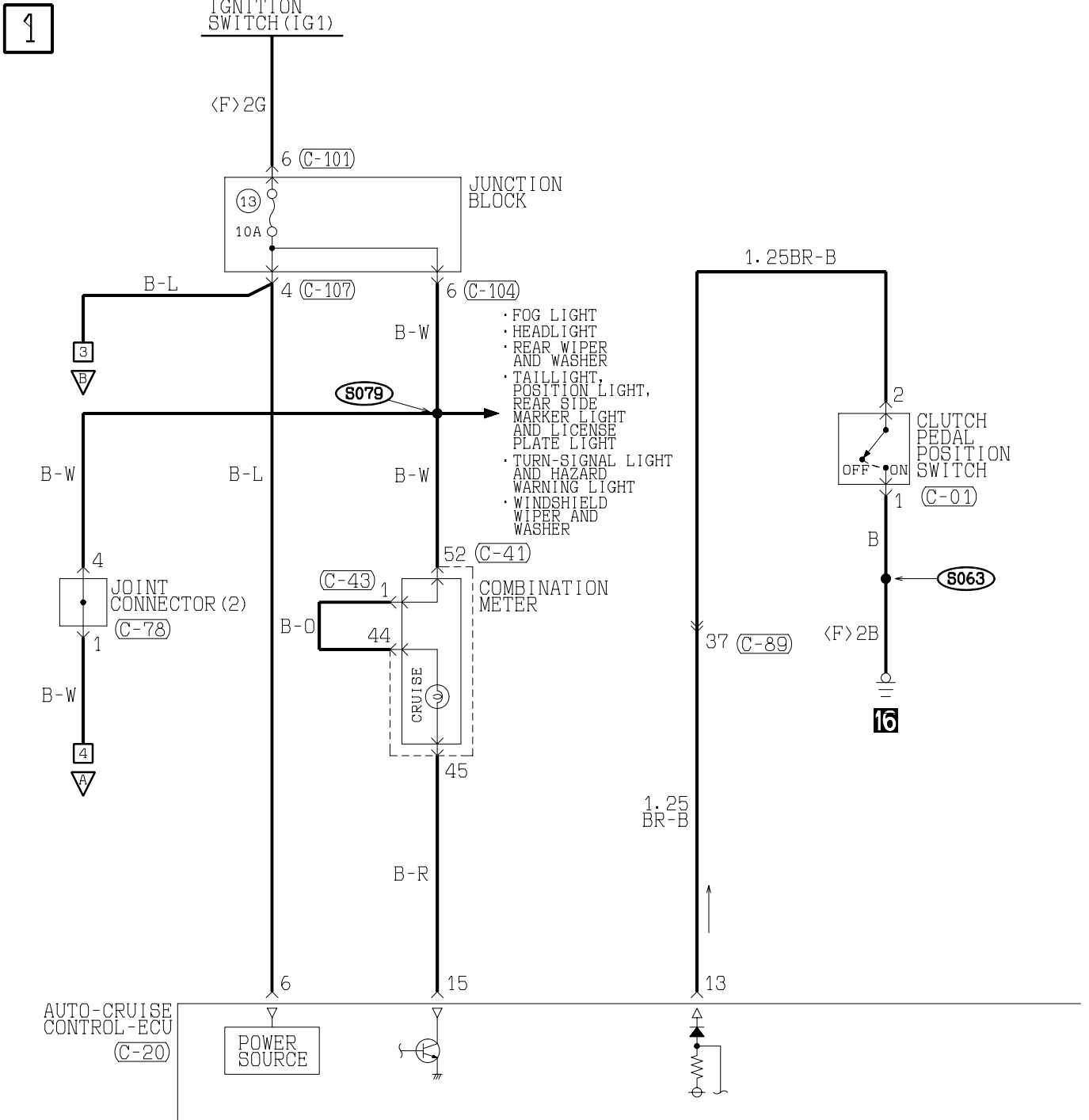

H1S15M39AA

**TSB Revision**



AUTO-CRUISE CONTROL SYSTEM <2.4L ENGINE-M/T> (CONTINUED)

3

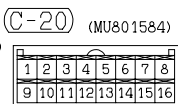
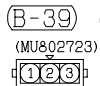
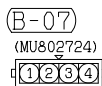
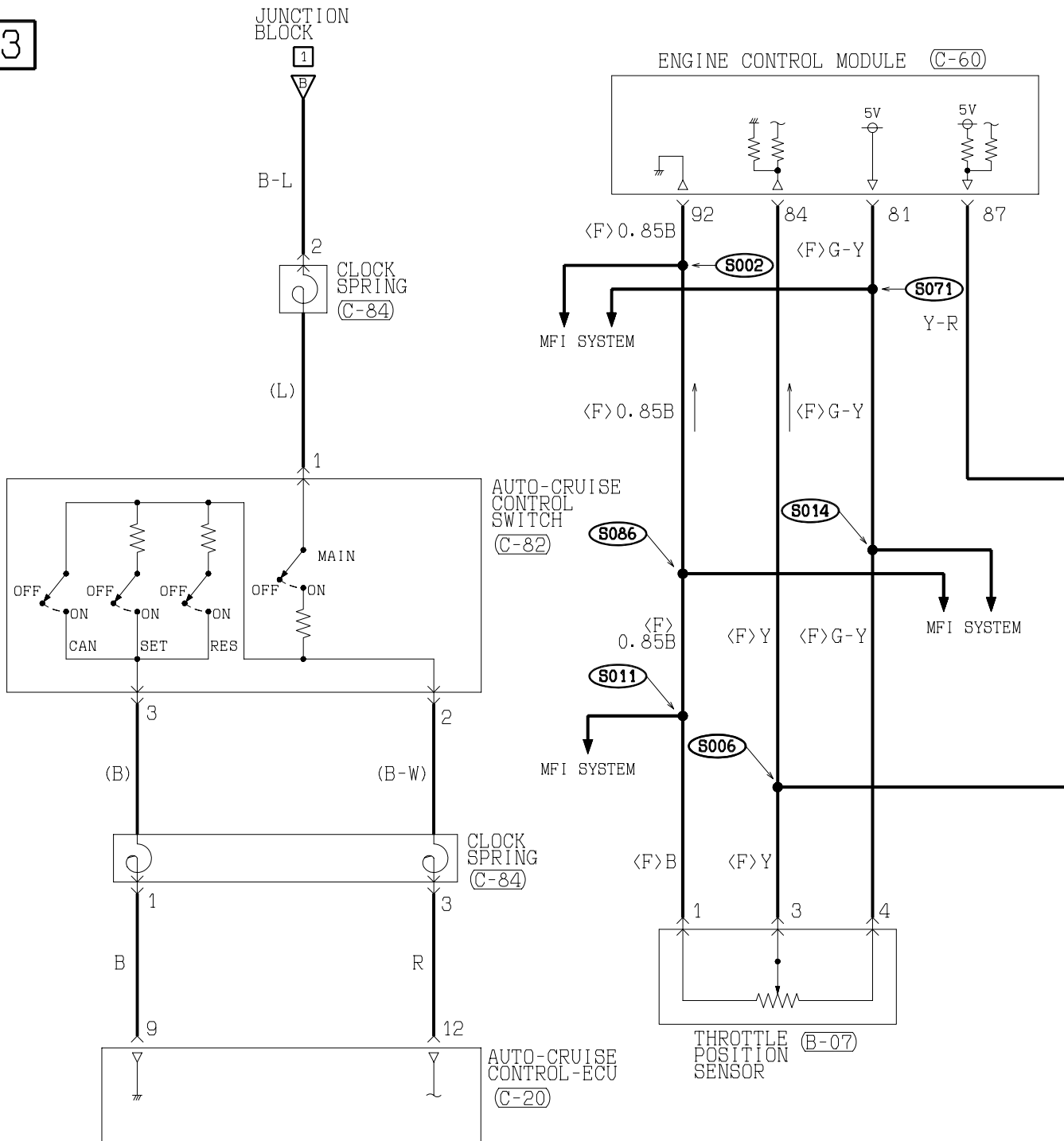

(C-28)

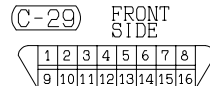
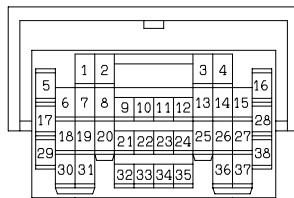

TSB Revision

4

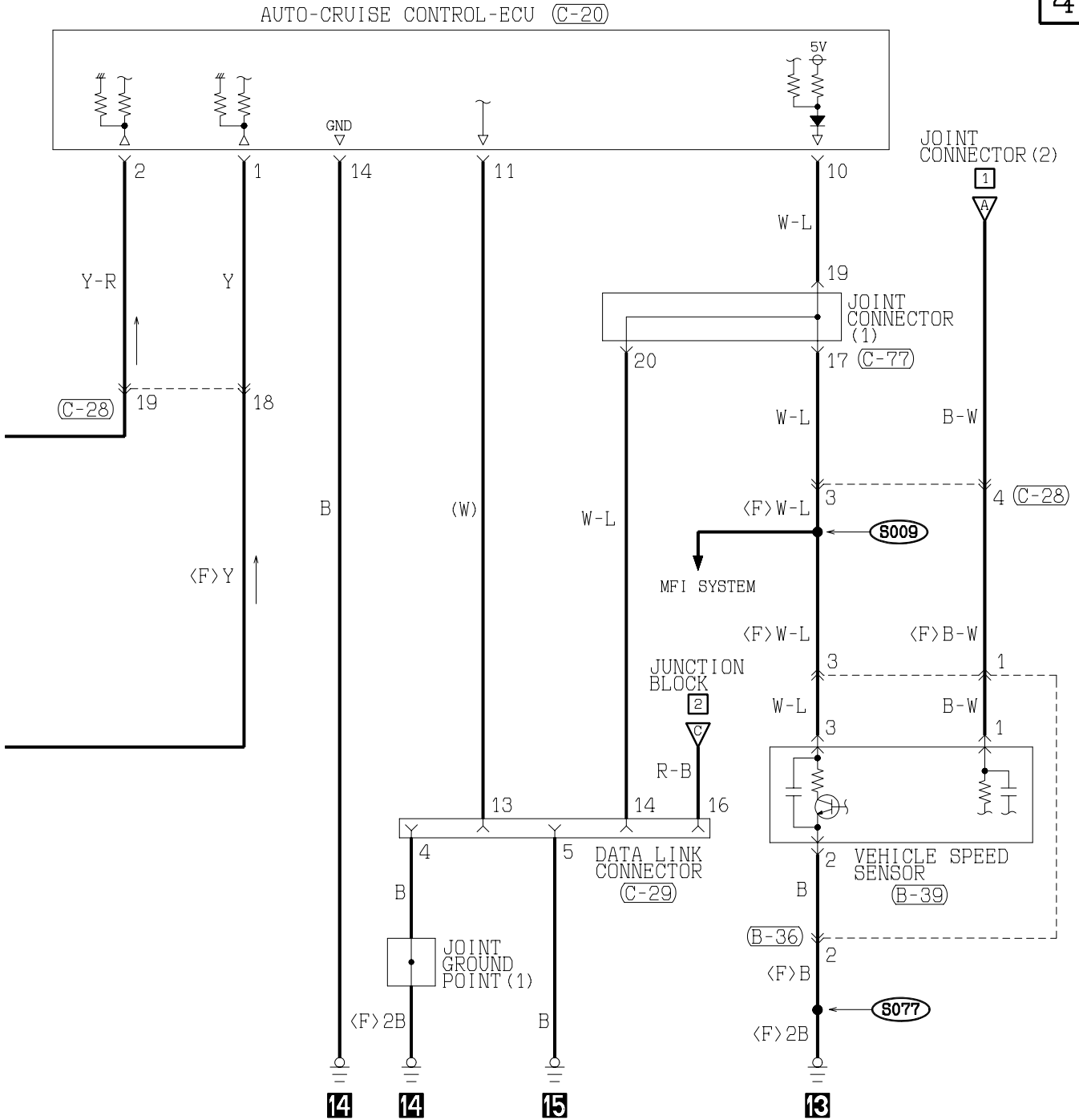

(C-77)

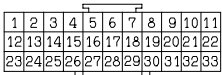

(C-82)



(C-84)



WIRE COLOR CODE  
 B : BLACK    BR : BROWN    G : GREEN    GR : GRAY    L : BLUE    LG : LIGHT GREEN    O : ORANGE  
 P : PINK    R : RED    SB : SKY BLUE    V : VIOLET    W : WHITE    Y : YELLOW

H1S15M39BB

**TSB Revision**

**AUTO-CRUISE CONTROL SYSTEM <2.4L ENGINE-A/T>**

M1901009300114

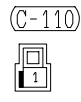
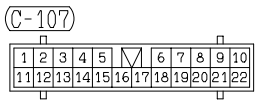
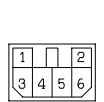
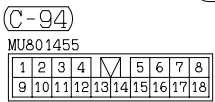
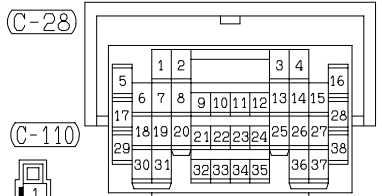
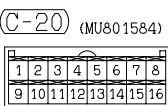
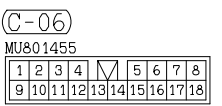
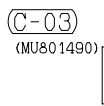
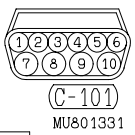
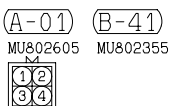
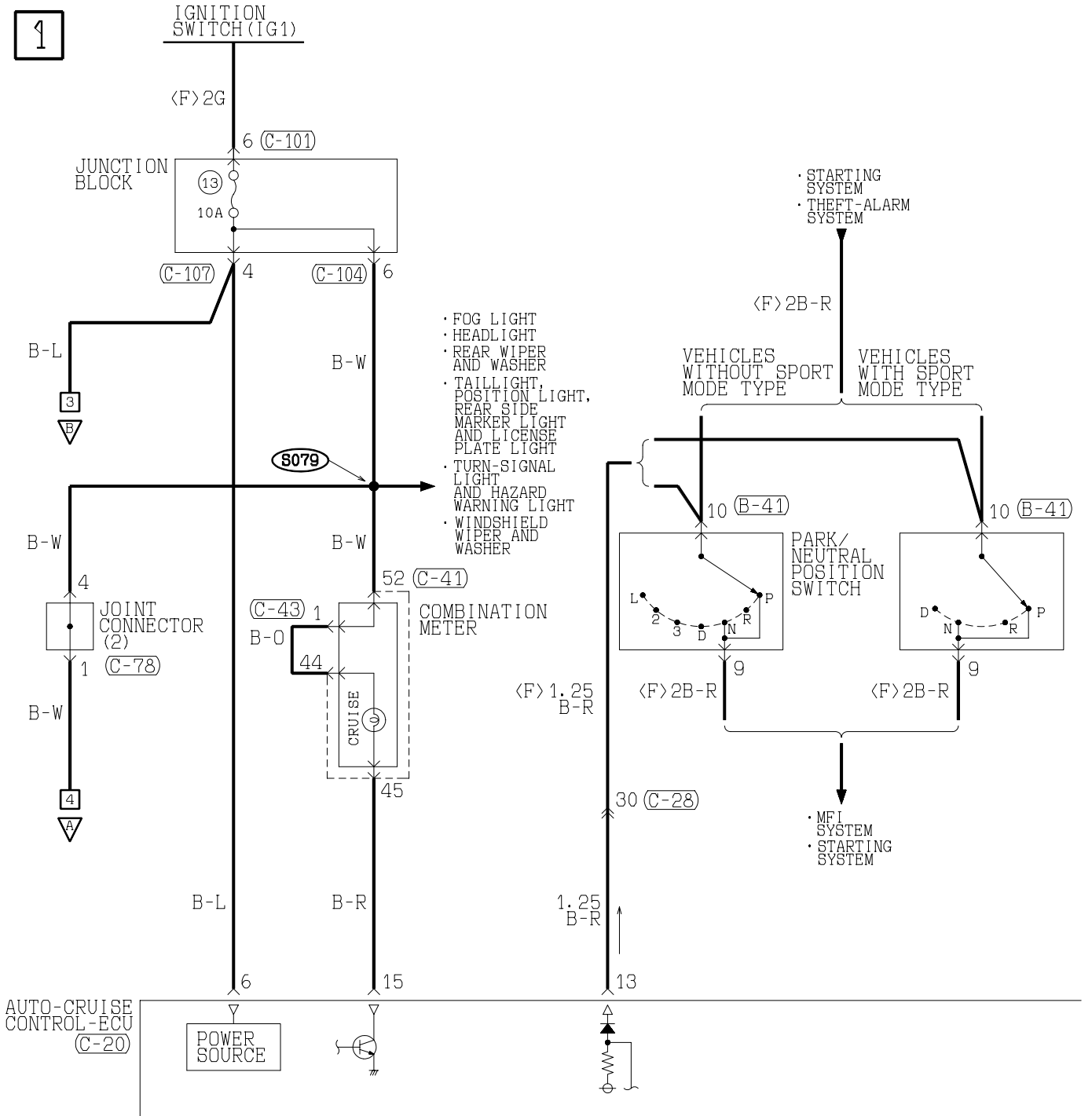

H1S15M40AA

TSB Revision



2

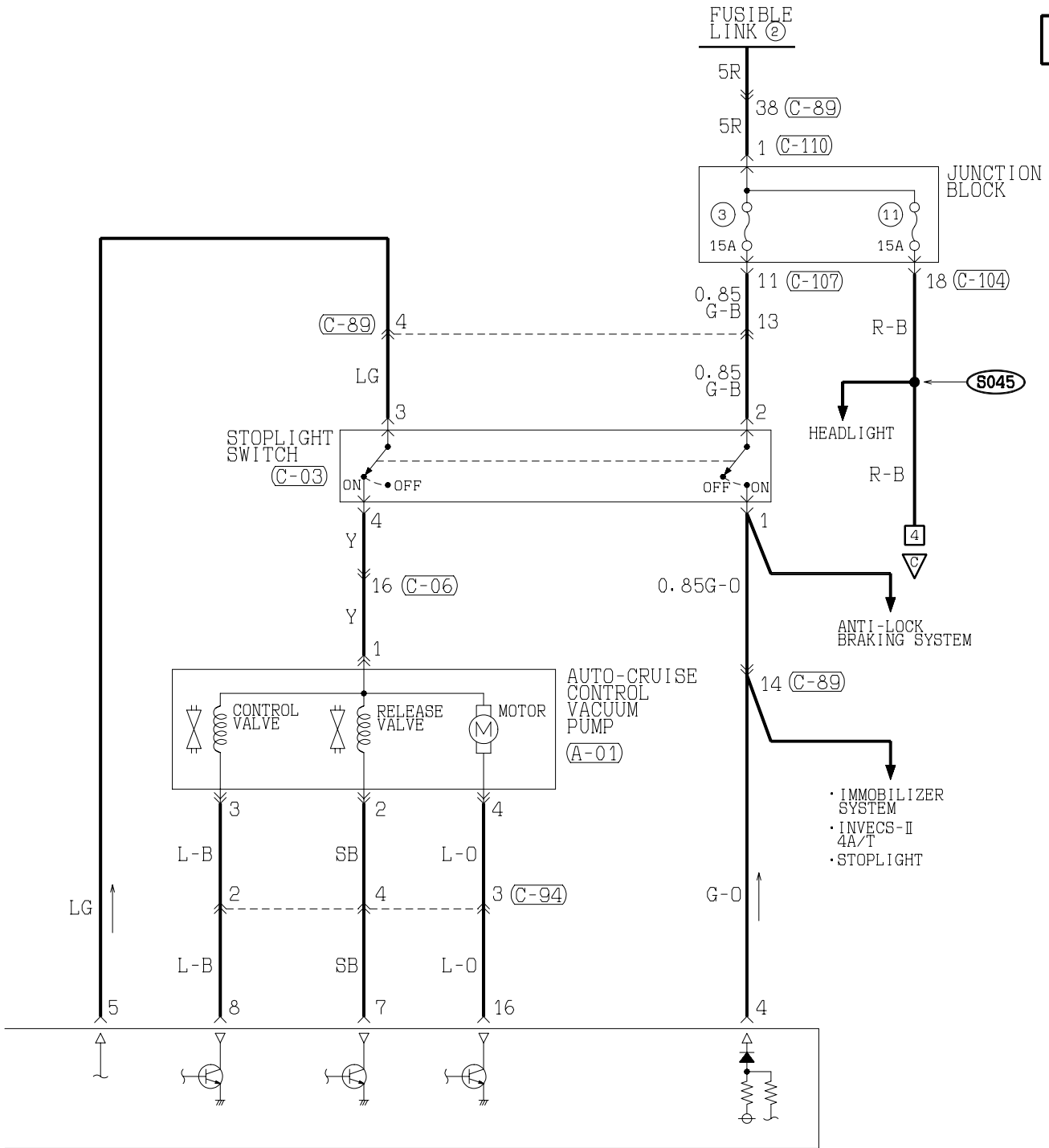

(C-41)

41	42	43	44	45	46	47	48	49	50	51	52	53	54	55	56
----	----	----	----	----	----	----	----	----	----	----	----	----	----	----	----

WIRE COLOR CODE  
 B : BLACK    BR : BROWN  
 L : BLUE    LG : LIGHT GREEN  
 R : RED    SB : SKY BLUE  
 Y : YELLOW

(C-43)

1	2	3	4	5	6	7	8	9	10	11	12	13	14	15	16
---	---	---	---	---	---	---	---	---	----	----	----	----	----	----	----

G : GREEN    GR : GRAY  
 O : ORANGE    P : PINK  
 V : VIOLET    W : WHITE

(C-78)

1	2	3	4	5	6	7	8	9	10	11
12	13	14	15	16	17	18	19	20	21	22
23	24	25	26	27	28	29	30	31	32	33

(C-89)

1	2	3	4	5	6	7	8	9	10	11	12	13
14	15	16	17	18	19	20	21	22	23	24	25	
26	27	28	29					30	31			
32	33	34		35		36	37					

**TSB Revision**

AUTO-CRUISE CONTROL SYSTEM <2.4L ENGINE-A/T> (CONTINUED)

3

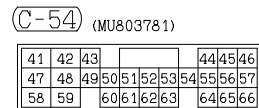
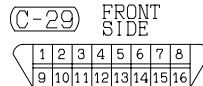
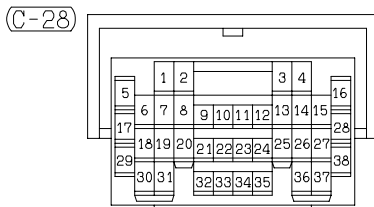
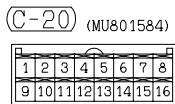
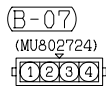
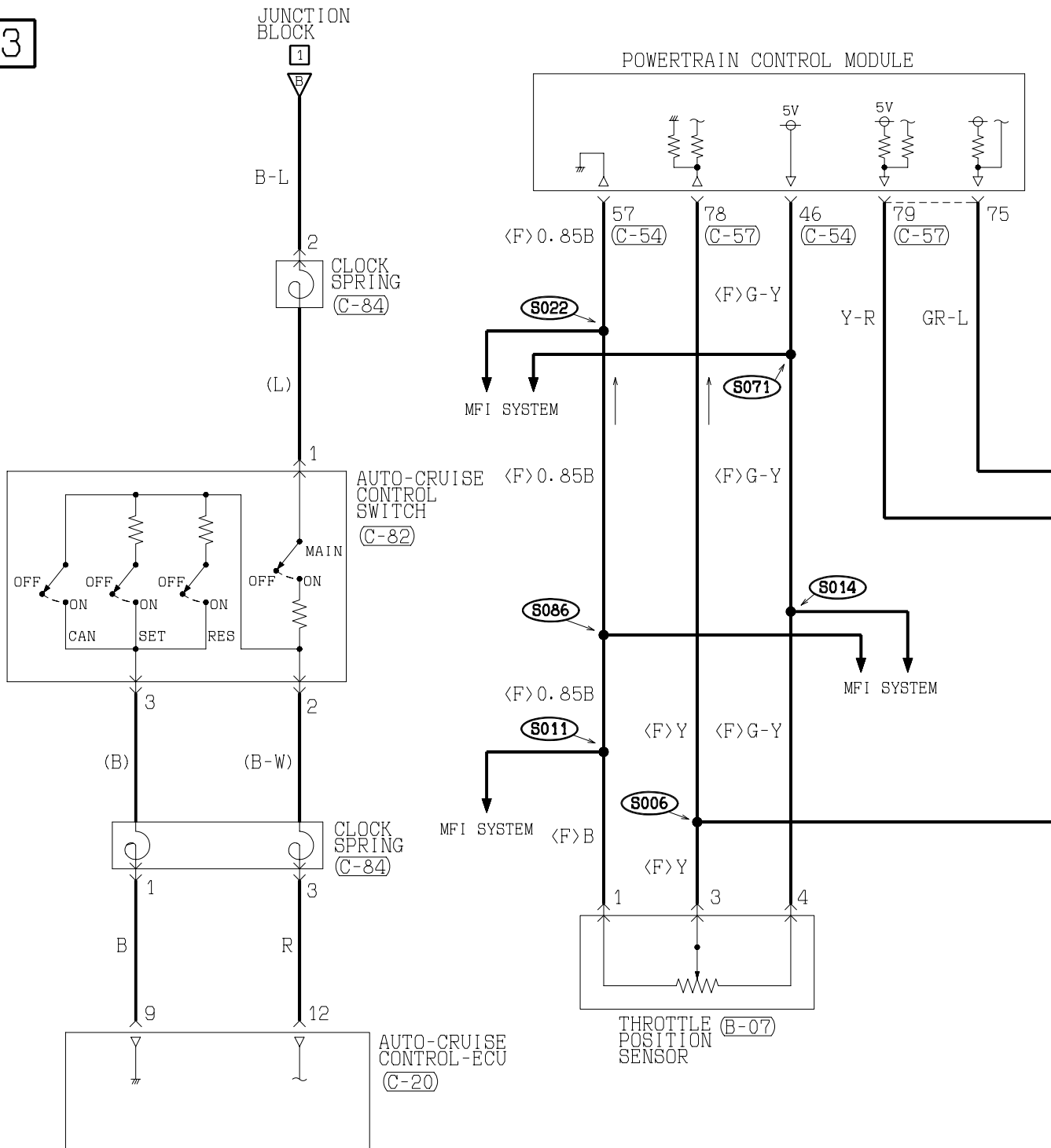

TSB Revision



# AUTO-CRUISE CONTROL SYSTEM <3.0L ENGINE-M/T>

M1901009300125

1

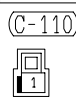
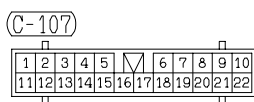
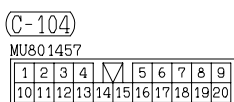
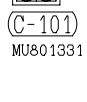
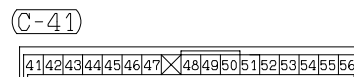
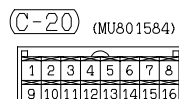
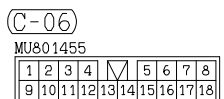
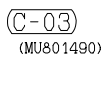
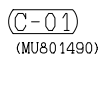
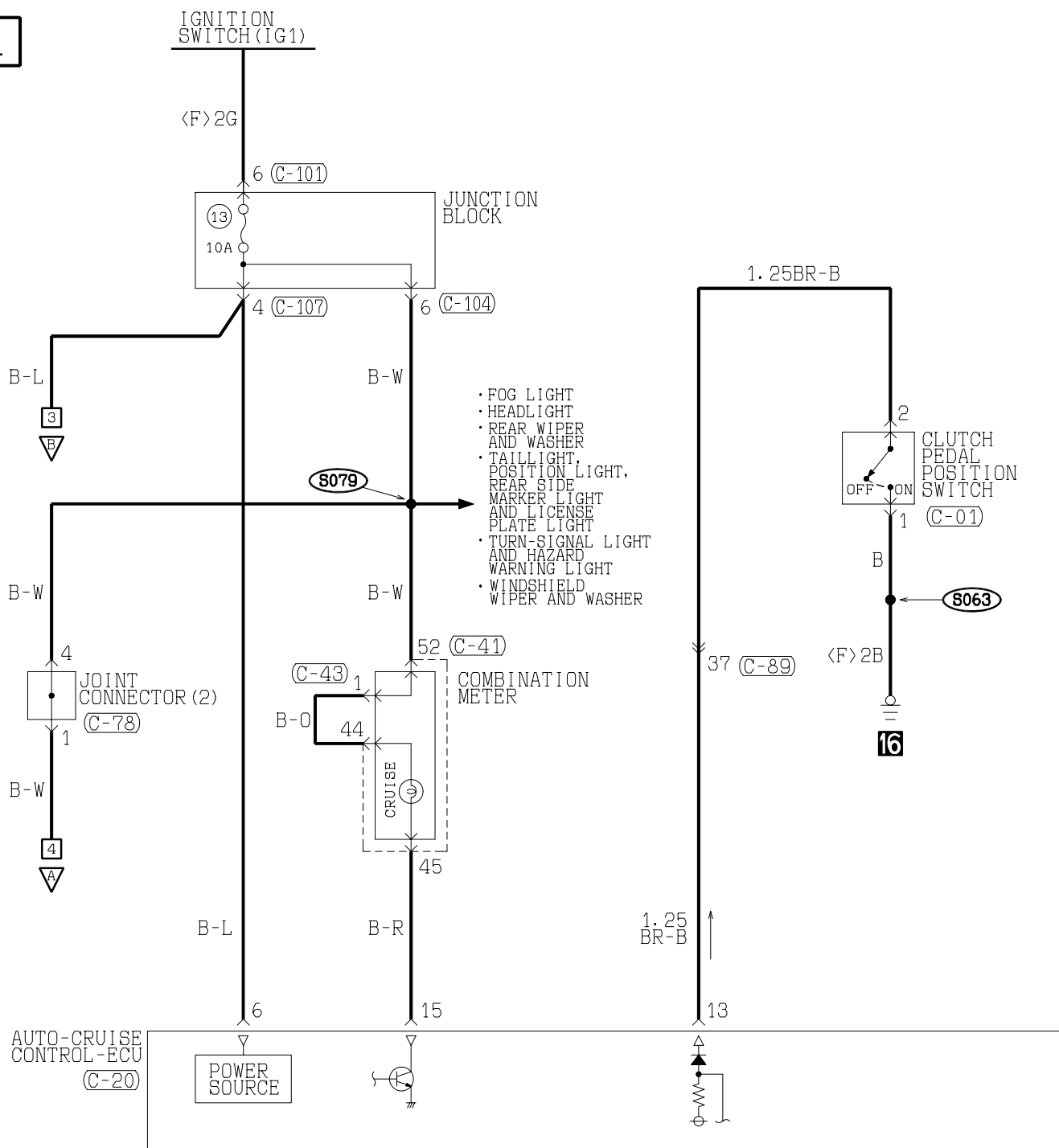

H1S15M41AA

TSB Revision

2

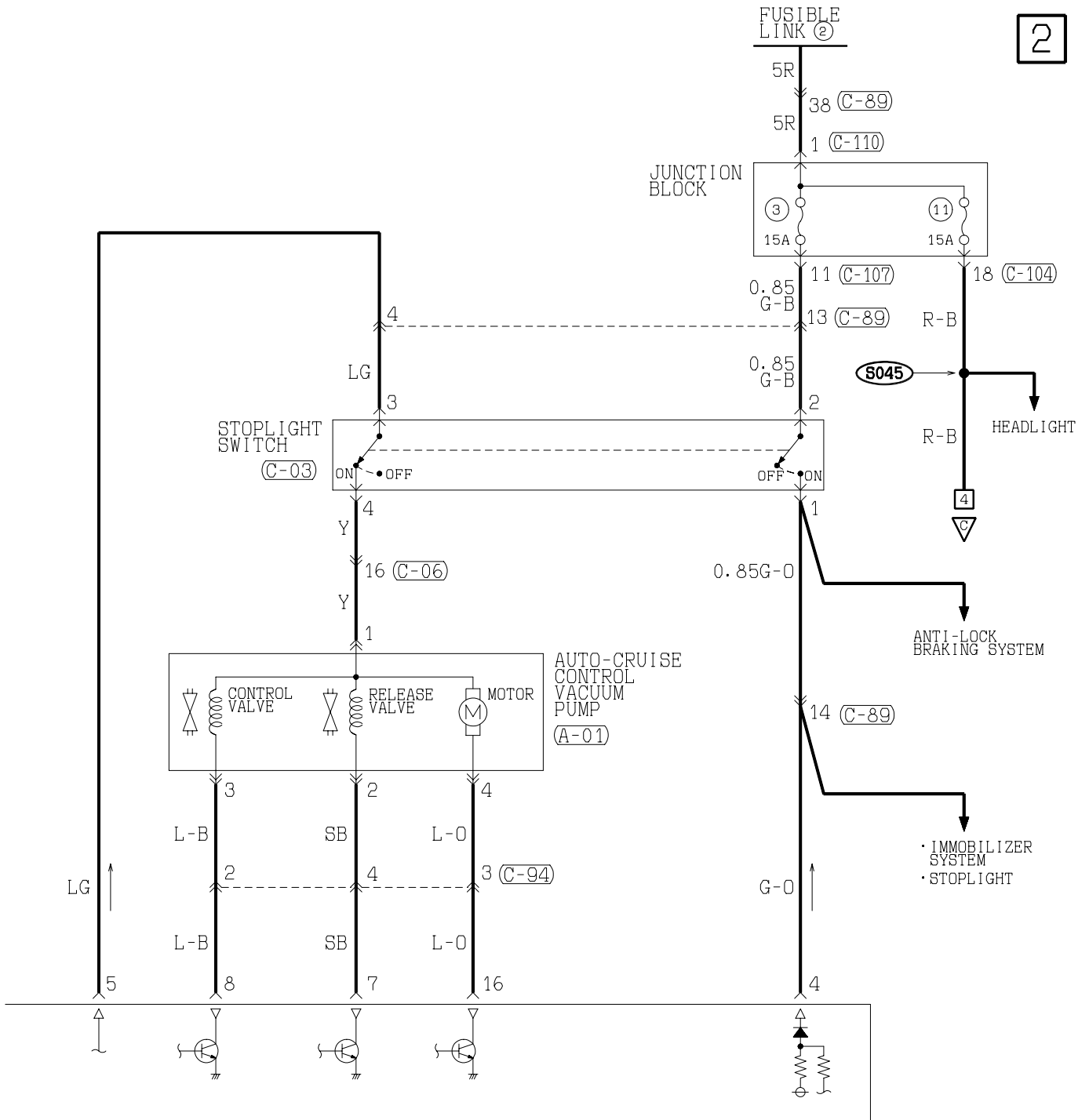

(C-43)

1	2	3	4	5	6	7	8	9	10	11	12	13	14	15	16
---	---	---	---	---	---	---	---	---	----	----	----	----	----	----	----

(C-78)

1	2	3	4	5	6	7	8	9	10	11
12	13	14	15	16	17	18	19	20	21	22
23	24	25	26	27	28	29	30	31	32	33

(C-89)

1	2	3	4	5	6	7	8	9	10	11	12	13
14	15	16	17	18	19	20	21	22	23	24	25	26
27	28	29	30	31	32	33	34	35	36	37	38	39

(C-94)

MU801455

1	2	3	4	5	6	7	8		
9	10	11	12	13	14	15	16	17	18

WIRE COLOR CODE  
 B : BLACK BR : BROWN G : GREEN GR : GRAY L : BLUE LG : LIGHT GREEN O : ORANGE  
 P : PINK R : RED SB : SKY BLUE V : VIOLET W : WHITE Y : YELLOW

H1S15M41AB

TSB Revision

AUTO-CRUISE CONTROL SYSTEM <3.0L ENGINE-M/T> (CONTINUED)

3

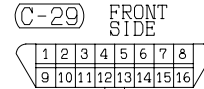
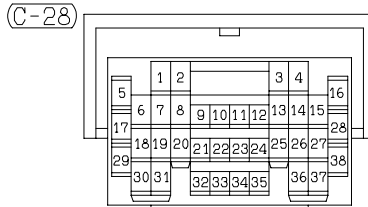
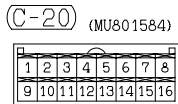
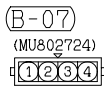
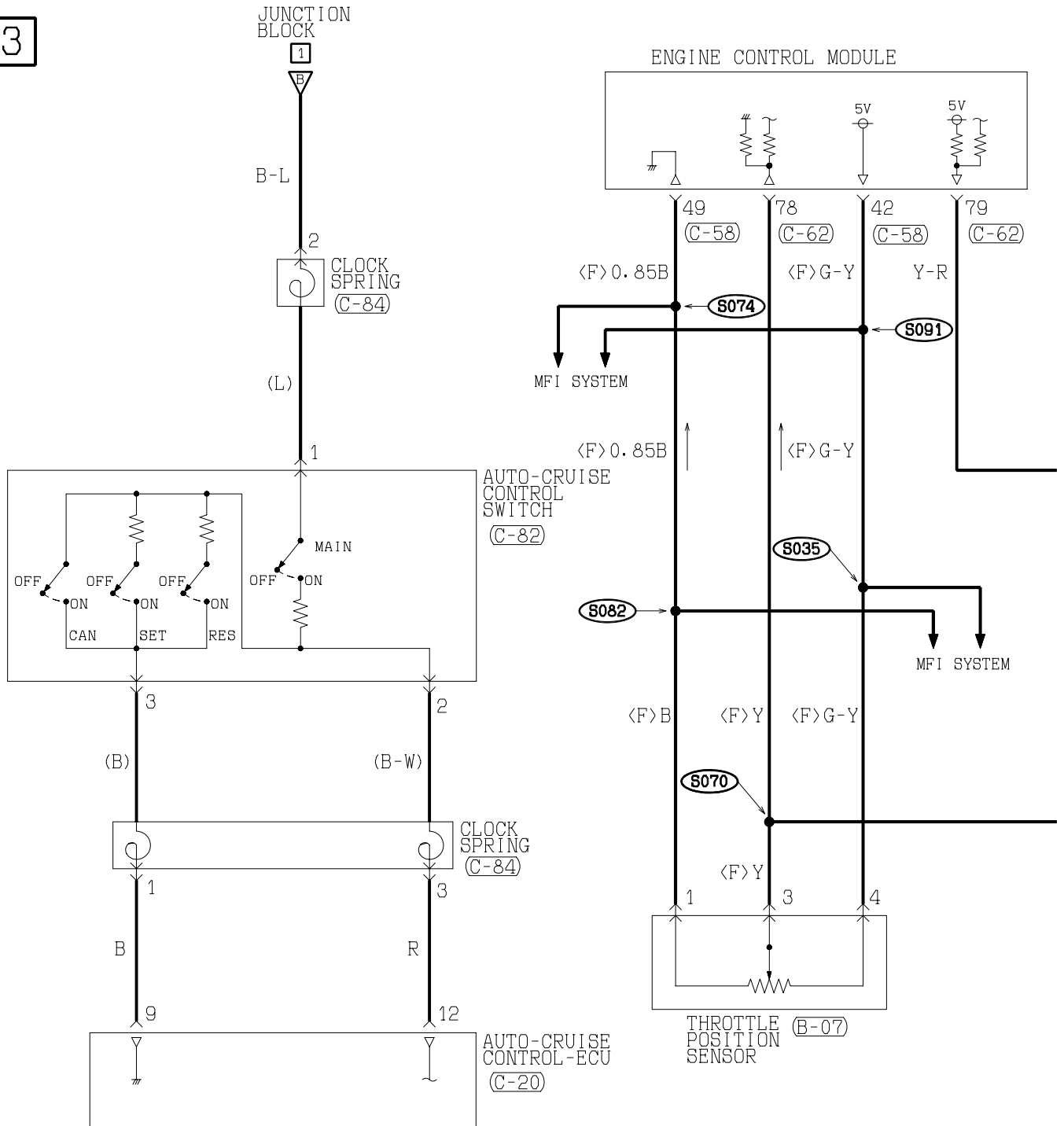

**4**

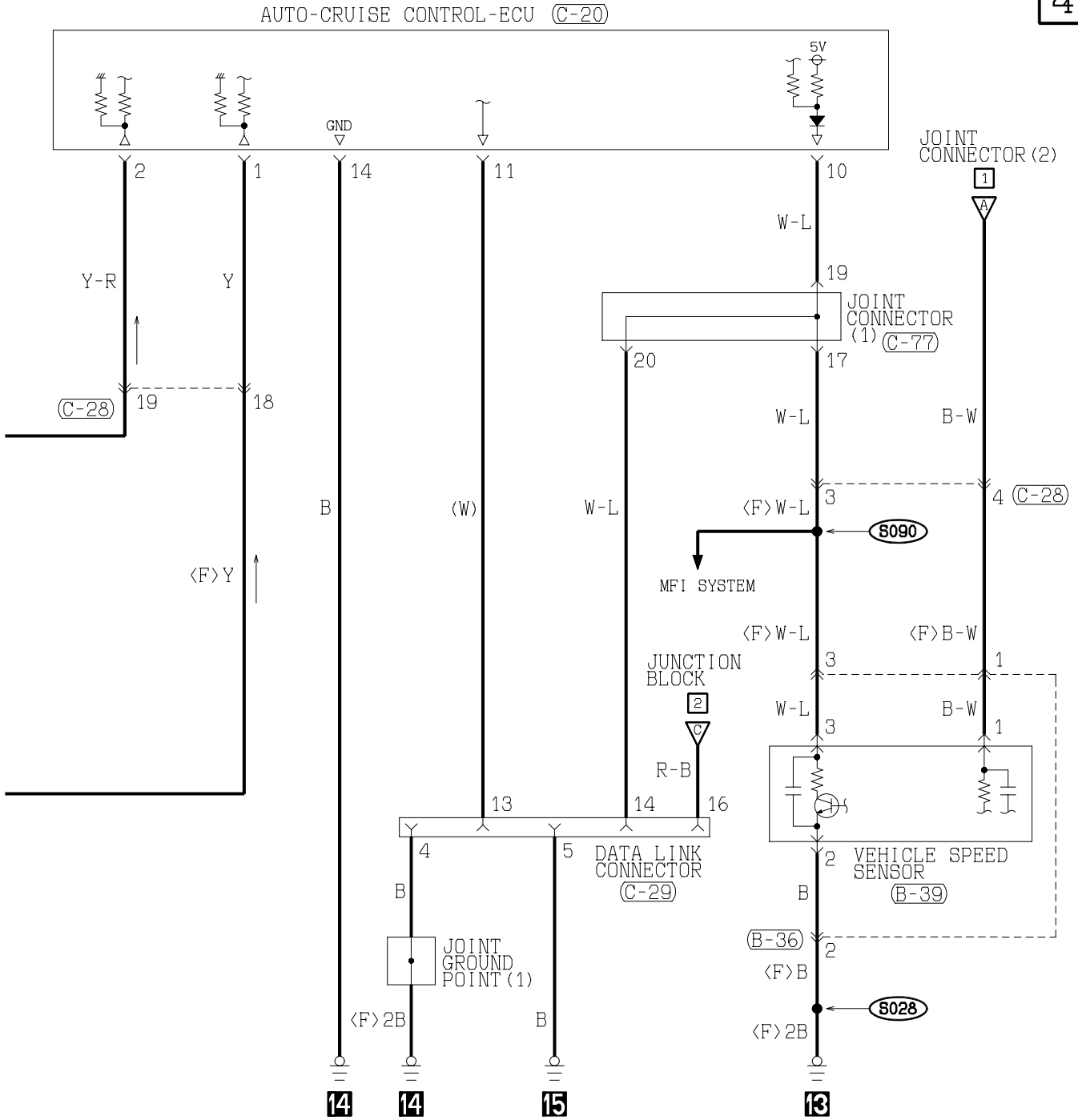

**(C-58)** (MU803782)

41	42	43	44	45	46	47
48	49	50	51	52	53	54
55	56	57	58	59	60	61
62	63	64	65	66	67	68

**(C-62)** (MU803783)

71	72	73	74	75	76	77
78	79	80	81	82	83	84
85	86	87	88	89	90	91
92	93	94	95	96	97	98
99	100					

**(C-77)**

1	2	3	4	5	6	7	8	9	10	11
12	13	14	15	16	17	18	19	20	21	22
23	24	25	26	27	28	29	30	31	32	33

**(C-82)**

1	2	3
---	---	---

**(C-84)** MU801691

1	2	3	4
---	---	---	---

WIRE COLOR CODE  
 B : BLACK BR : BROWN G : GREEN GR : GRAY L : BLUE LG : LIGHT GREEN O : ORANGE  
 P : PINK R : RED SB : SKY BLUE V : VIOLET W : WHITE Y : YELLOW

H1S15M41BB

**TSB Revision**

**AUTO-CRUISE CONTROL SYSTEM <3.0L ENGINE-A/T>**

M1901009300136

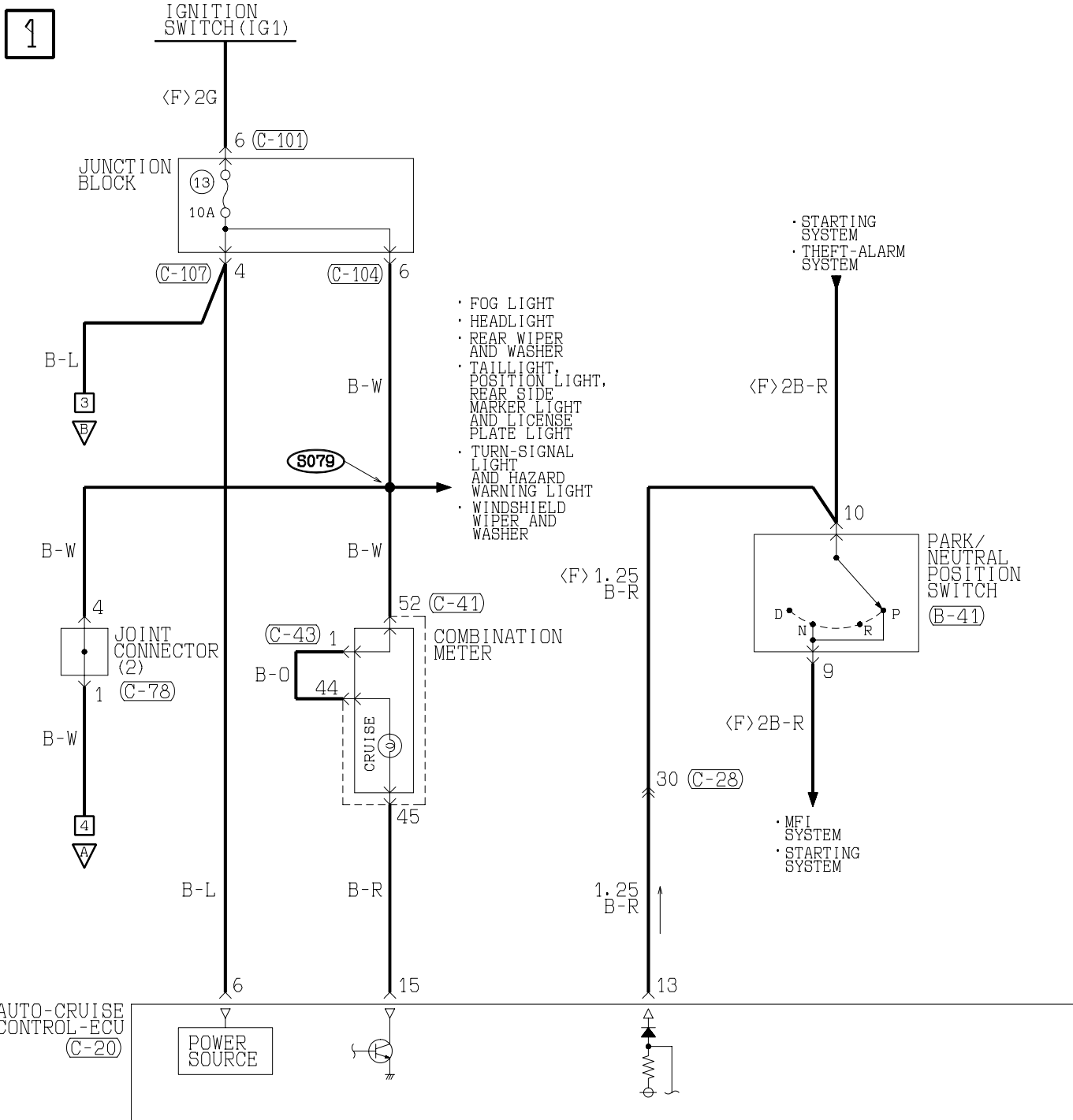

- FOG LIGHT
- HEADLIGHT
- REAR WIPER AND WASHER
- TAILLIGHT, POSITION LIGHT, REAR SIDE MARKER LIGHT AND LICENSE PLATE LIGHT
- TURN-SIGNAL LIGHT AND HAZARD WARNING LIGHT
- WINDSHIELD WIPER AND WASHER

- STARTING SYSTEM
- THEFT-ALARM SYSTEM

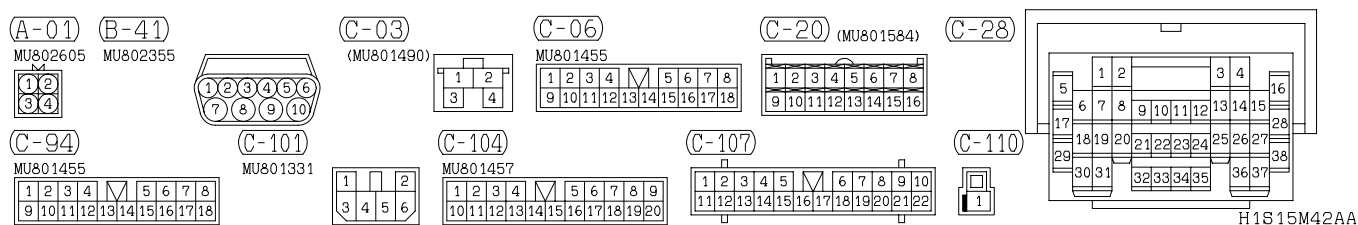
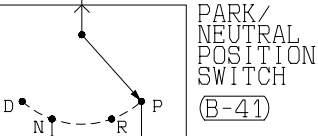

TSB Revision



2

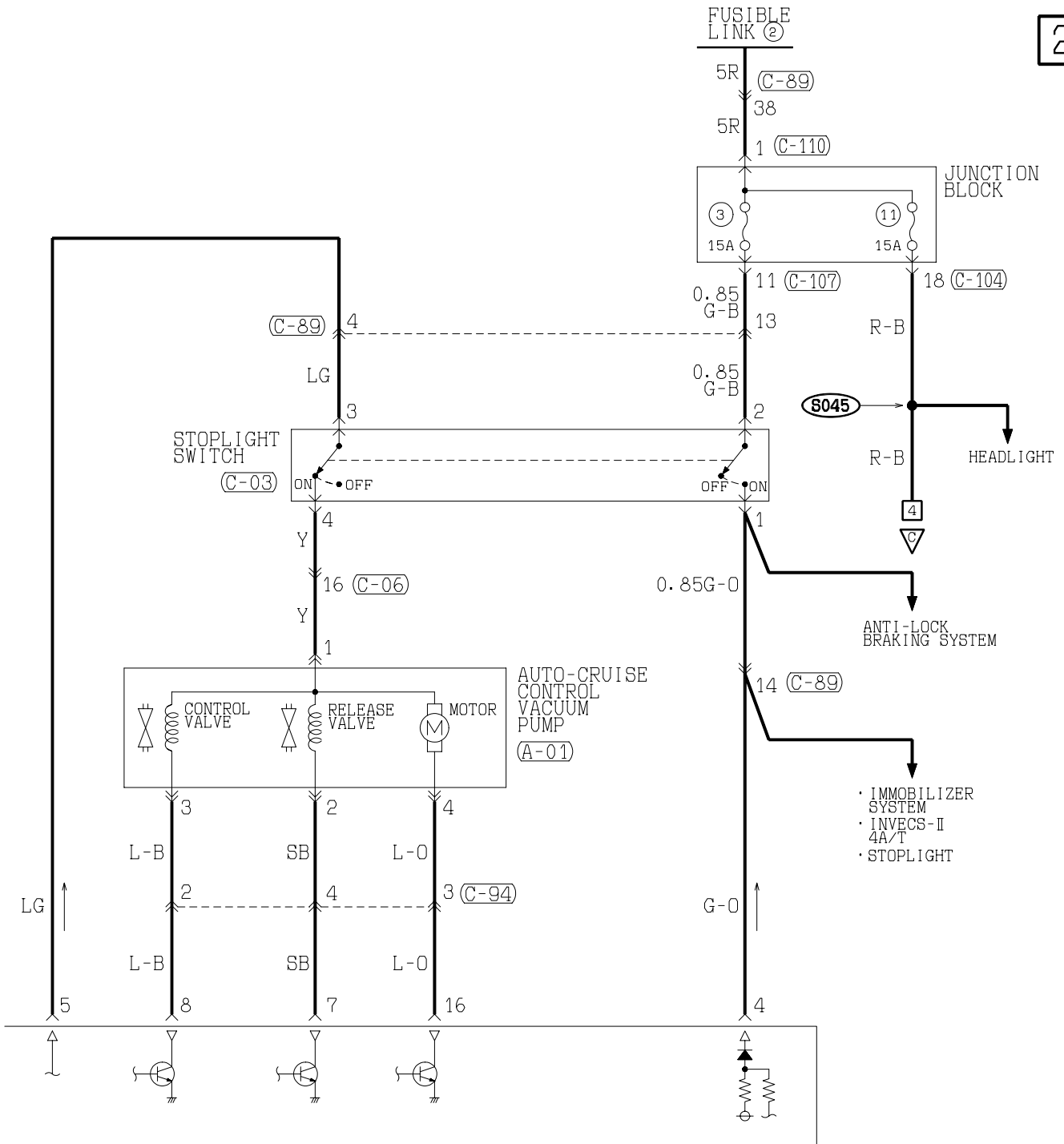

(C-41)

41	42	43	44	45	46	47	48	49	50	51	52	53	54	55	56
----	----	----	----	----	----	----	----	----	----	----	----	----	----	----	----

(C-43)

1	2	3	4	5	6	7	8	9	10	11	12	13	14	15	16
---	---	---	---	---	---	---	---	---	----	----	----	----	----	----	----

(C-78)

1	2	3	4	5	6	7	8	9	10	11
12	13	14	15	16	17	18	19	20	21	22
23	24	25	26	27	28	29	30	31	32	33

(C-89)

1	2	3	4	5	6	7	8	9	10	11	12	13
14	15	16	17	18	19	20	21	22	23	24	25	26
27	28	29	30	31	32	33	34	35	36	37	38	39

**WIRE COLOR CODE**  
 B : BLACK      BR: BROWN  
 L : BLUE      LG: LIGHT GREEN  
 R : RED      SB: SKY BLUE  
 Y : YELLOW

G : GREEN      GR: GRAY  
 O : ORANGE      P : PINK  
 V : VIOLET      W : WHITE

**TSB Revision**

AUTO-CRUISE CONTROL SYSTEM <3.0L ENGINE-A/T> (CONTINUED)

3

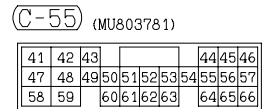
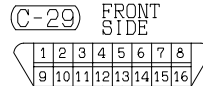
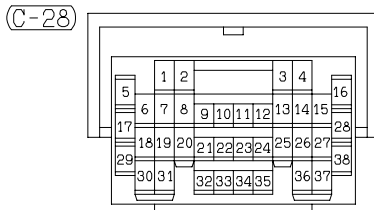
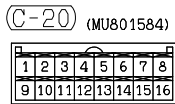
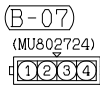
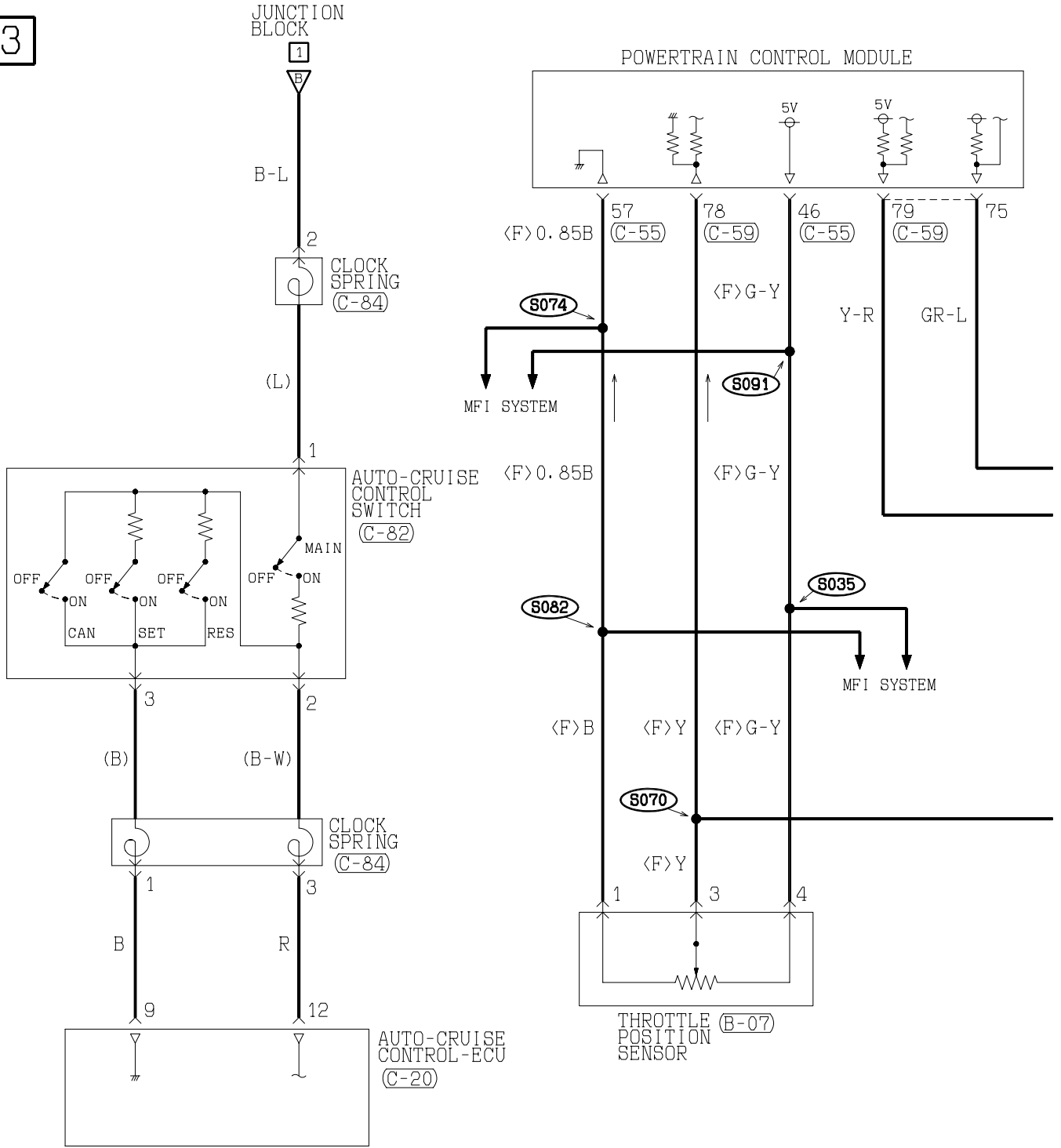

H1S15M42BA

TSB Revision

4

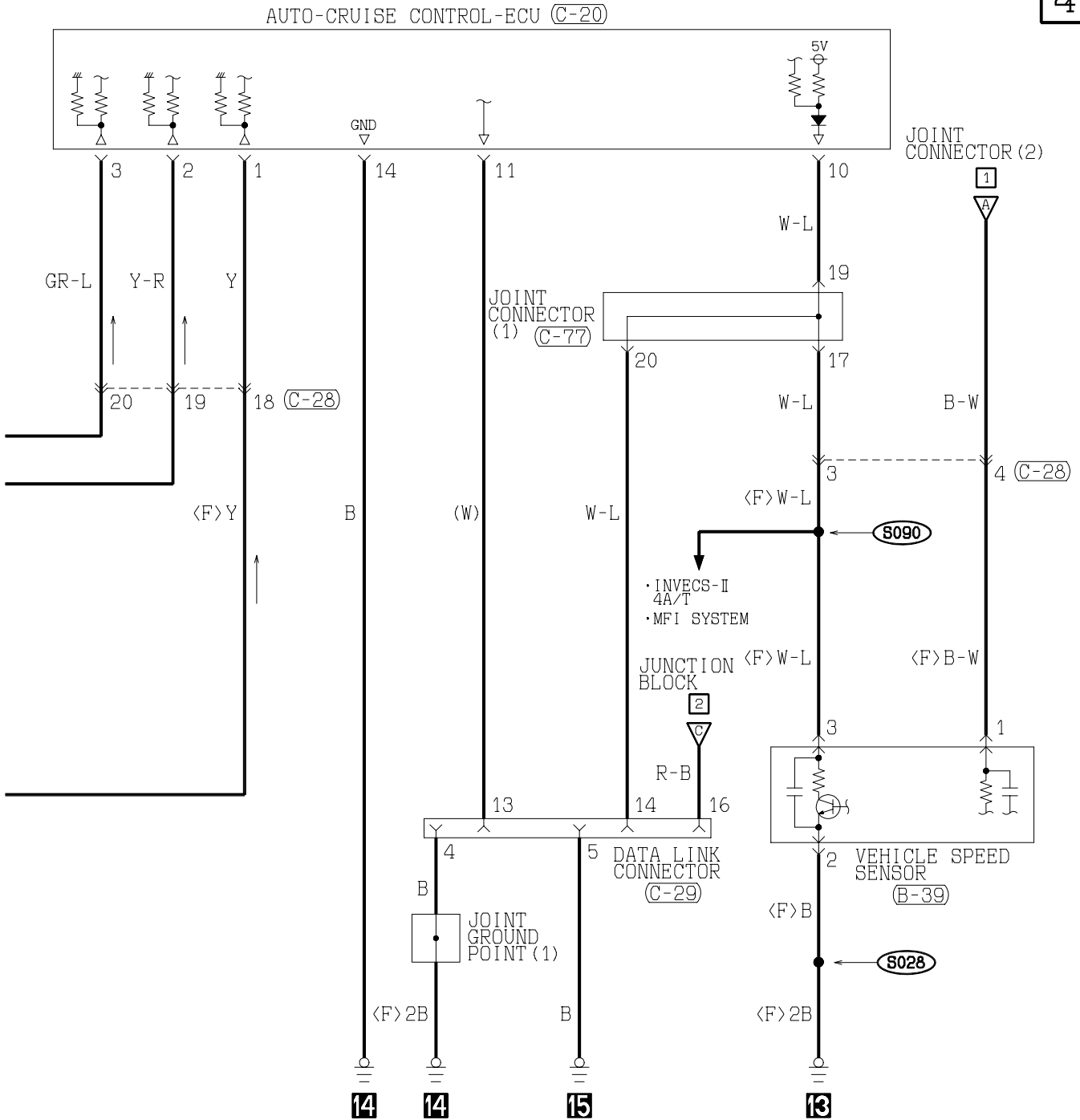

(C-59) (MU803782)

71	72	73	74		75	76	77				
78	79	80	81	82	83	84	85	86	87	88	89
90	91	92	93	94	95	96	97	98			

(C-77)

1	2	3	4	5	6	7	8	9	10	11
12	13	14	15	16	17	18	19	20	21	22
23	24	25	26	27	28	29	30	31	32	33

(C-82)

1	2	3
---	---	---

(C-84)

MU801691

1	2	3	4
---	---	---	---

**WIRE COLOR CODE**

B : BLACK    BR : BROWN    G : GREEN    GR : GRAY    L : BLUE    LG : LIGHT GREEN    O : ORANGE  
 P : PINK    R : RED    SB : SKY BLUE    V : VIOLET    W : WHITE    Y : YELLOW

H1S15M42BB

**TSB Revision**

# ANTI-LOCK BRAKING SYSTEM (ABS) <VEHICLES WITHOUT TCL>

M1901008400107

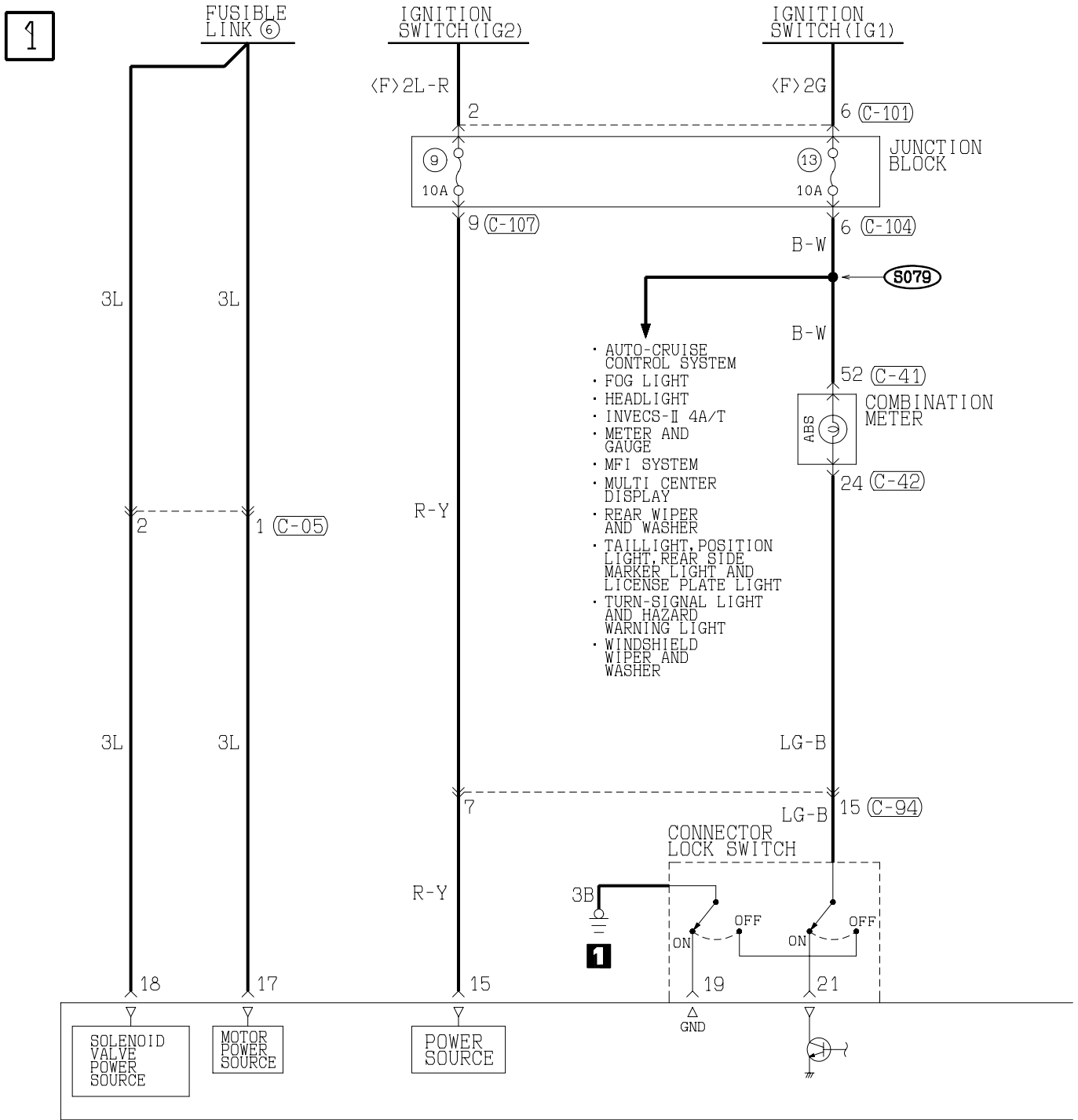

(A-02)

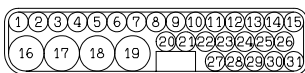

(C-03)  
(MU801490)



(C-05)



(C-06)

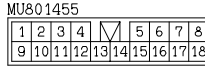

(C-41)

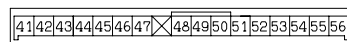

(C-107)

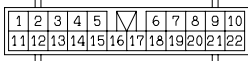

(C-110)



H1S15M35AA

TSB Revision

2

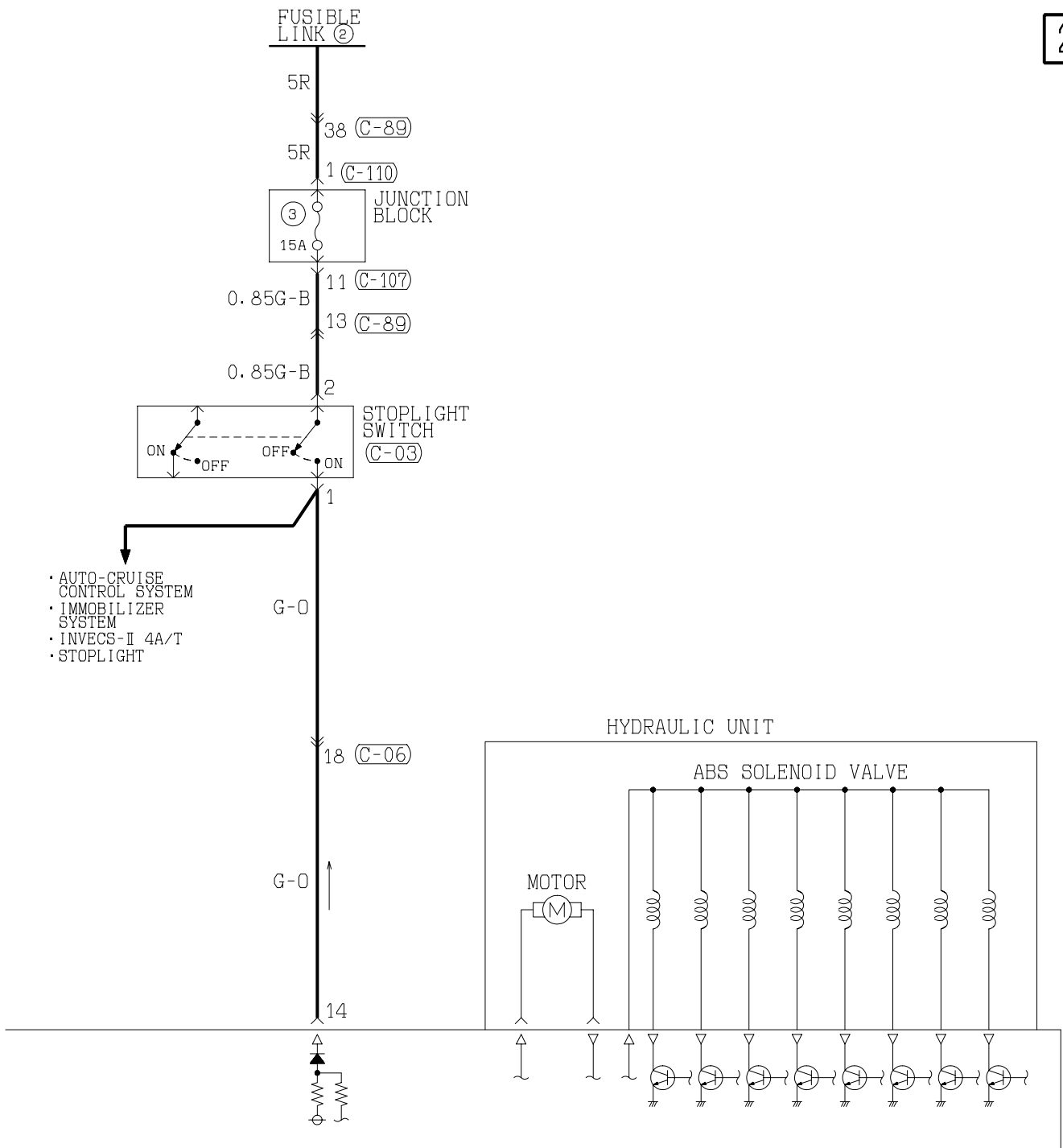

(C-42)

21	22	23	24	25	26	27	28	29	30	31	32	33	34
----	----	----	----	----	----	----	----	----	----	----	----	----	----

(C-89)

1	2	3	4	5	6	7	8	9	10	11	12	13		
14	15	16	17	18	19	20	21	22	23	24	25			
26	27	28	29		30	31		32	33	34	35	36	37	38

(C-94)

MU801455

1	2	3	4	5	6	7	8		
9	10	11	12	13	14	15	16	17	18

(C-101)

MU801331

1	2		
3	4	5	6

(C-104)

MU801457

1	2	3	4	5	6	7	8	9		
10	11	12	13	14	15	16	17	18	19	20

WIRE COLOR CODE  
 B : BLACK BR : BROWN  
 P : PINK R : RED

G : GREEN GR : GRAY  
 SB : SKY BLUE V : VIOLET

L : BLUE LG : LIGHT GREEN  
 W : WHITE Y : YELLOW

O : ORANGE

H1S15M35AB

**TSB Revision**

ANTI-LOCK BRAKING SYSTEM (ABS) <VEHICLES WITHOUT TCL> (CONTINUED)

3

WHEEL SPEED SENSOR

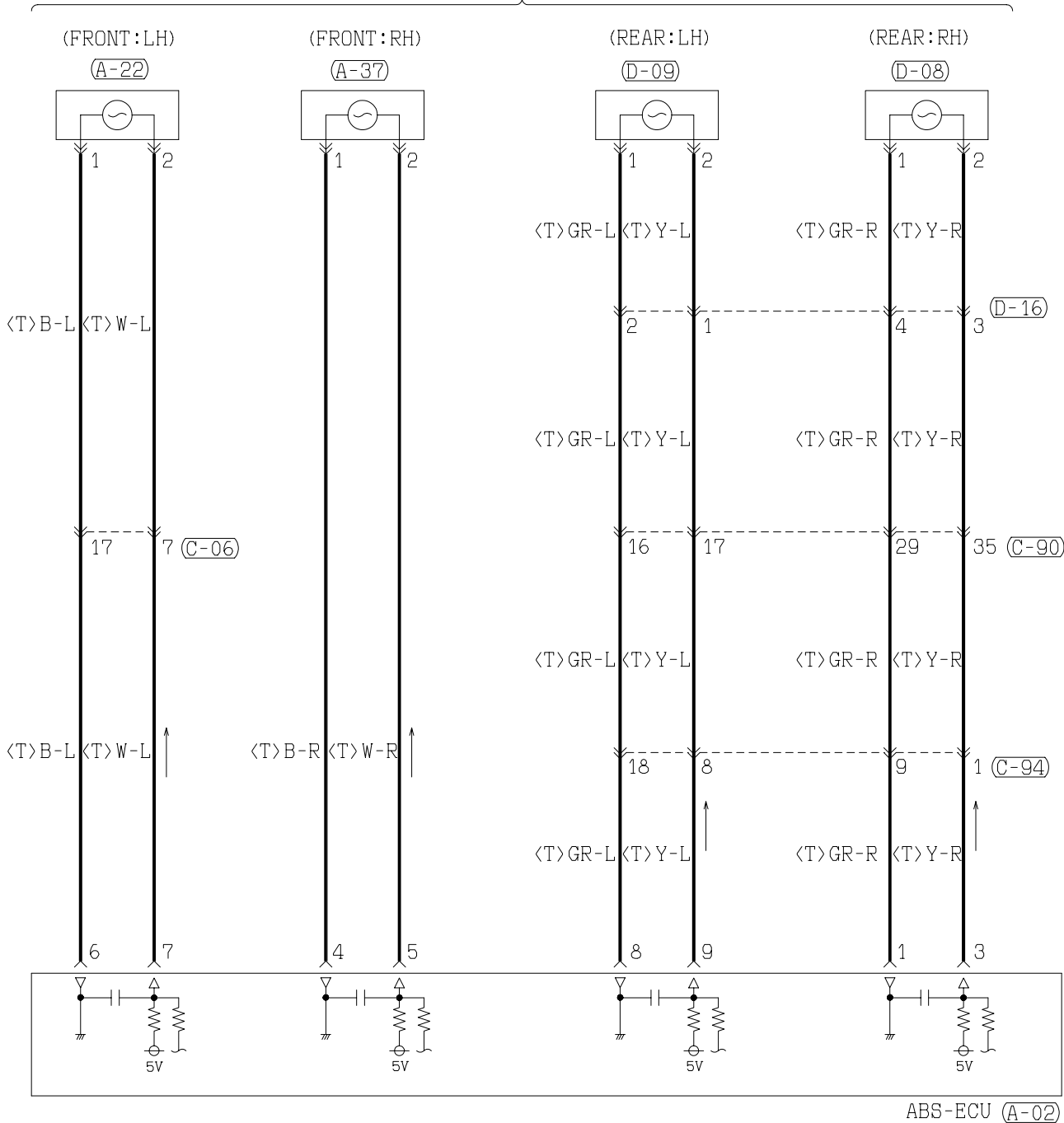

(A-02)

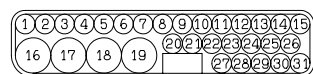

(D-09)

MU802601 MU802355

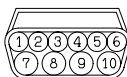

(A-22)

MU802601



(A-37)

MU802601



(C-06)

MU801455

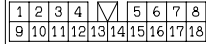

(C-29)

FRONT SIDE

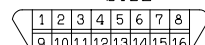

(C-77)

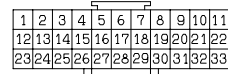

TSB Revision

**4**

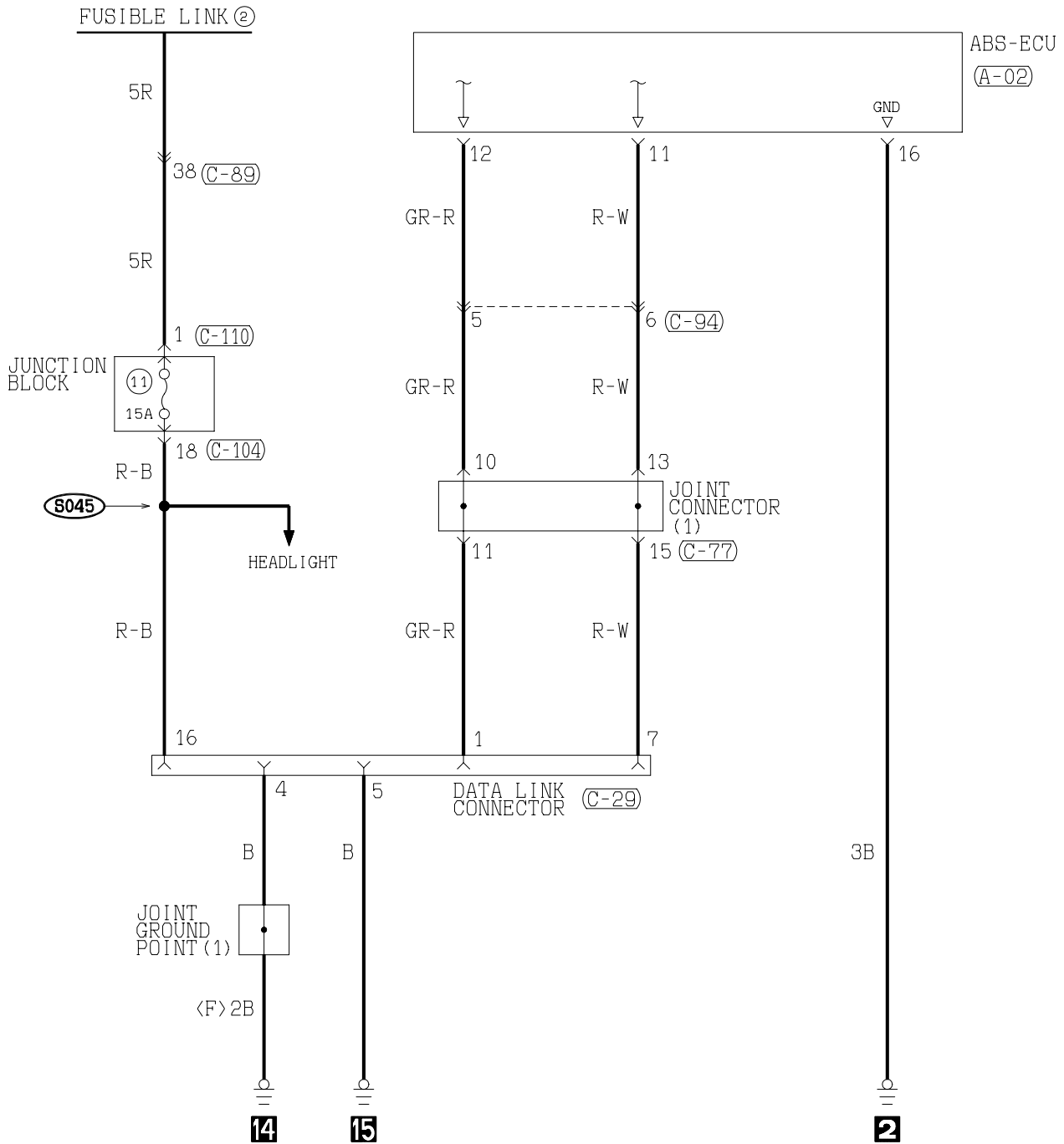

**(C-89)**

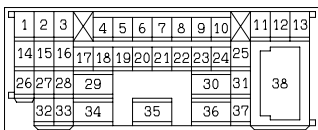

**(C-90)**

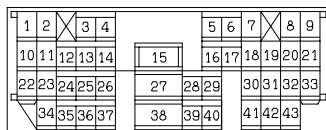

**(C-94)**

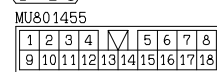

**(C-104)**

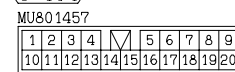

**(C-110)**



**(D-08)**



**WIRE COLOR CODE**

- B : BLACK      BR: BROWN      G : GREEN      GR: GRAY
- L : BLUE      LG: LIGHT GREEN      O : ORANGE      P : PINK
- R : RED      SB: SKY BLUE      V : VIOLET      W : WHITE
- Y : YELLOW

H1S15M35BB

**TSB Revision**

# ANTI-LOCK BRAKING SYSTEM (ABS) <VEHICLES WITH TCL>

M1901008400118

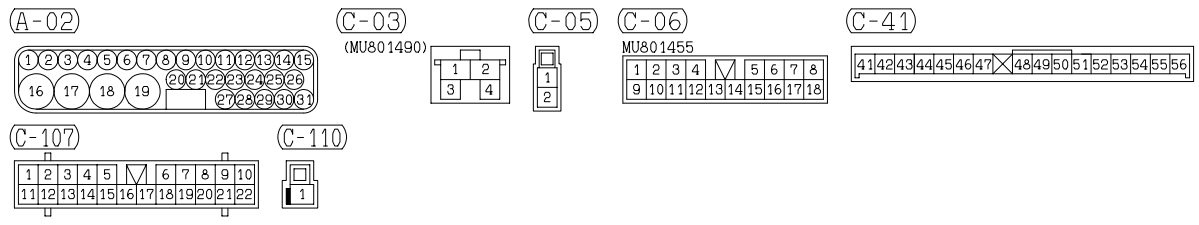
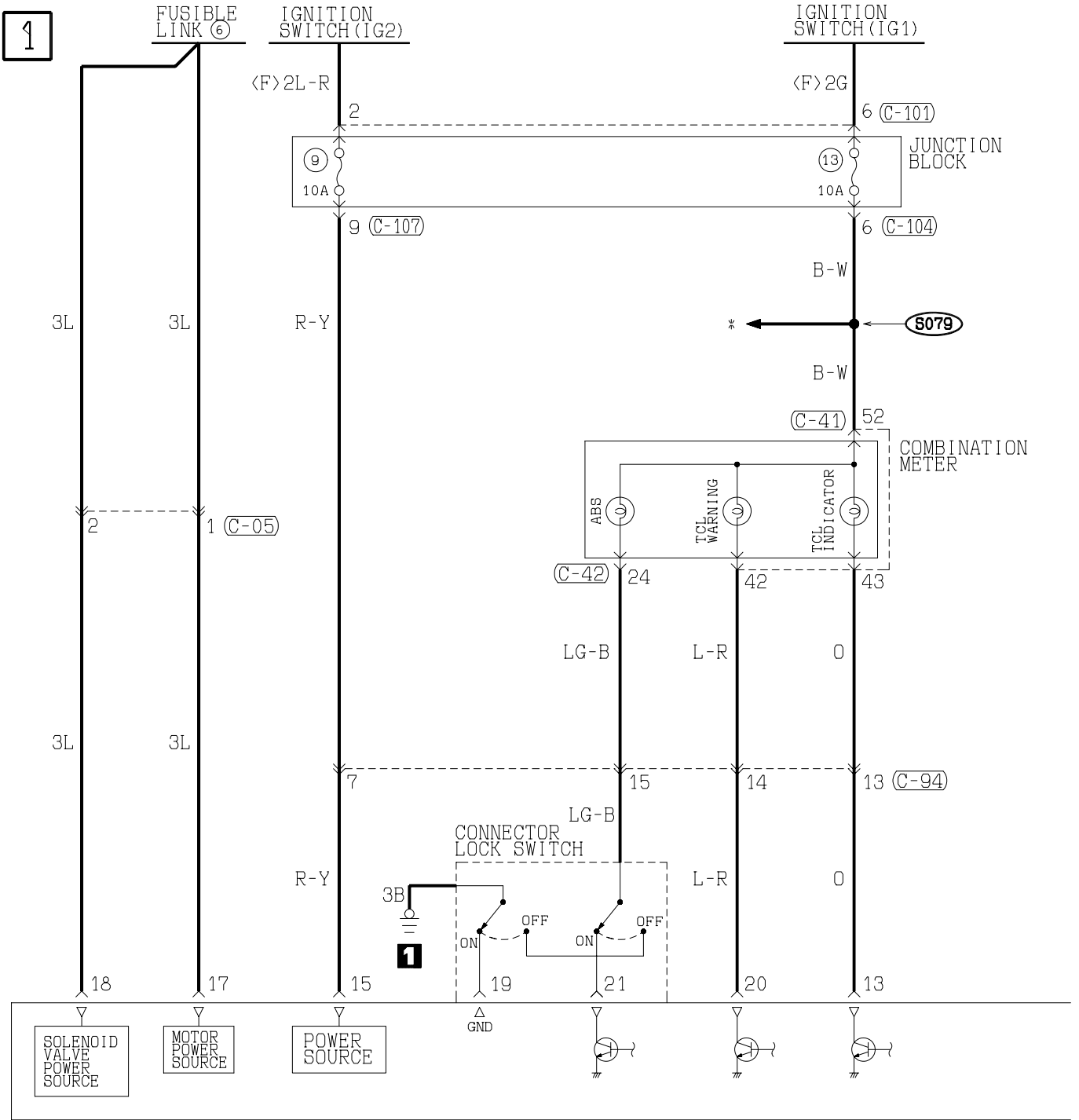

H1S15M36AA



2

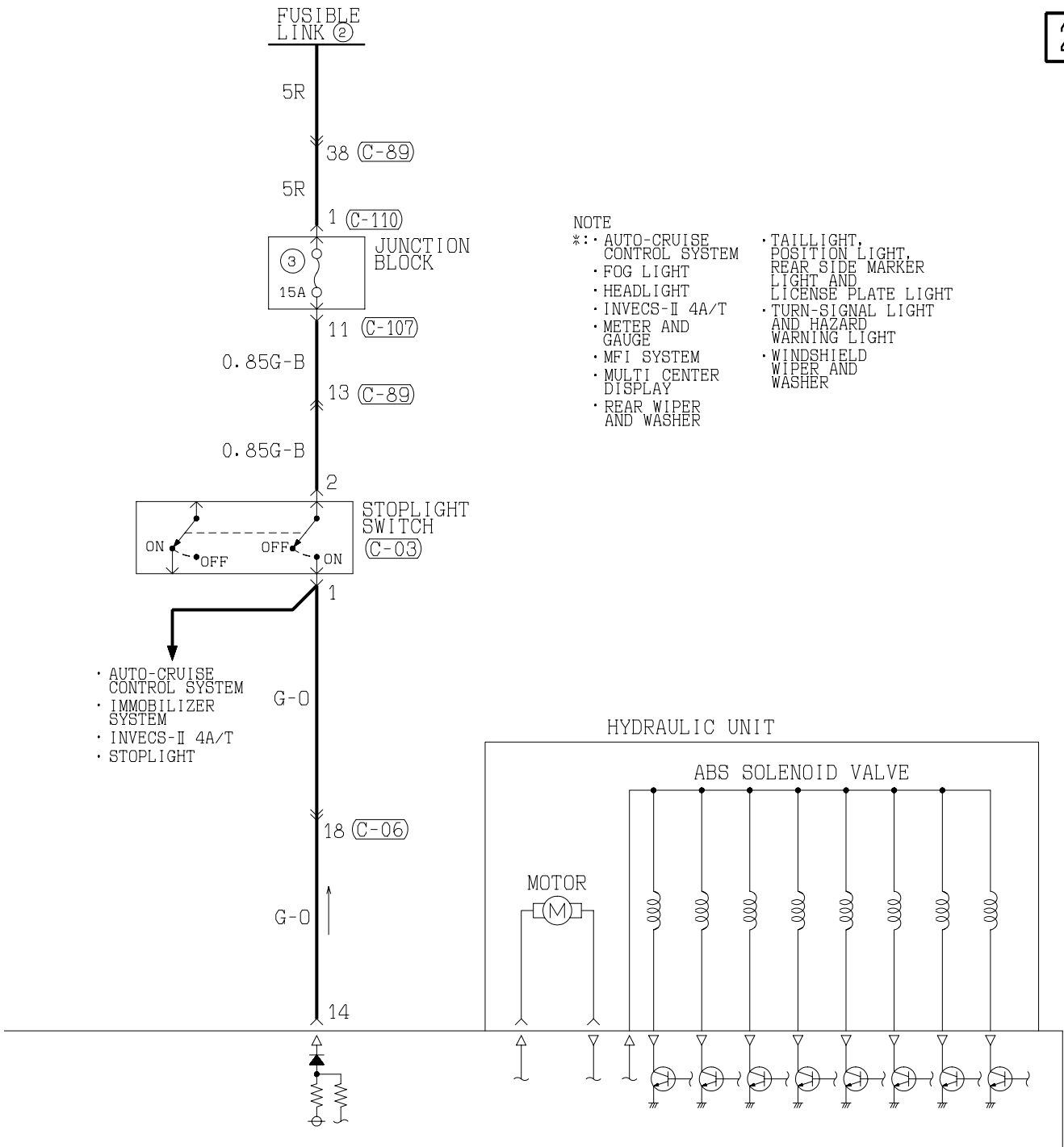

- NOTE
- \*: • AUTO-CRUISE CONTROL SYSTEM
  - FOG LIGHT
  - HEADLIGHT
  - INVECS-II 4A/T
  - METER AND GAUGE
  - MFI SYSTEM
  - MULTI CENTER DISPLAY
  - REAR WIPER AND WASHER
  - TAILLIGHT, POSITION LIGHT, REAR SIDE MARKER LIGHT AND LICENSE PLATE LIGHT
  - TURN-SIGNAL LIGHT AND HAZARD WARNING LIGHT
  - WINDSHIELD WIPER AND WASHER

- AUTO-CRUISE CONTROL SYSTEM
- IMMOBILIZER SYSTEM
- INVECS-II 4A/T
- STOPLIGHT

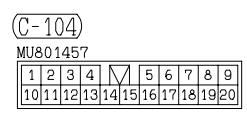
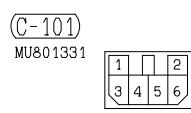
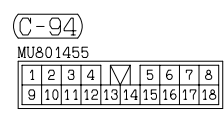
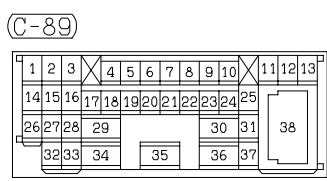
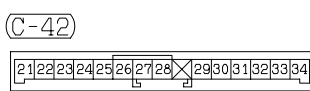

WIRE COLOR CODE  
 B : BLACK BR: BROWN L : BLUE LG: LIGHT GREEN O : ORANGE  
 P : PINK R : RED SB: SKY BLUE V : VIOLET W : WHITE Y : YELLOW

H1S15M36AB

**TSB Revision**

ANTI-LOCK BRAKING SYSTEM (ABS) <VEHICLES WITH TCL> (CONTINUED)

3

WHEEL SPEED SENSOR

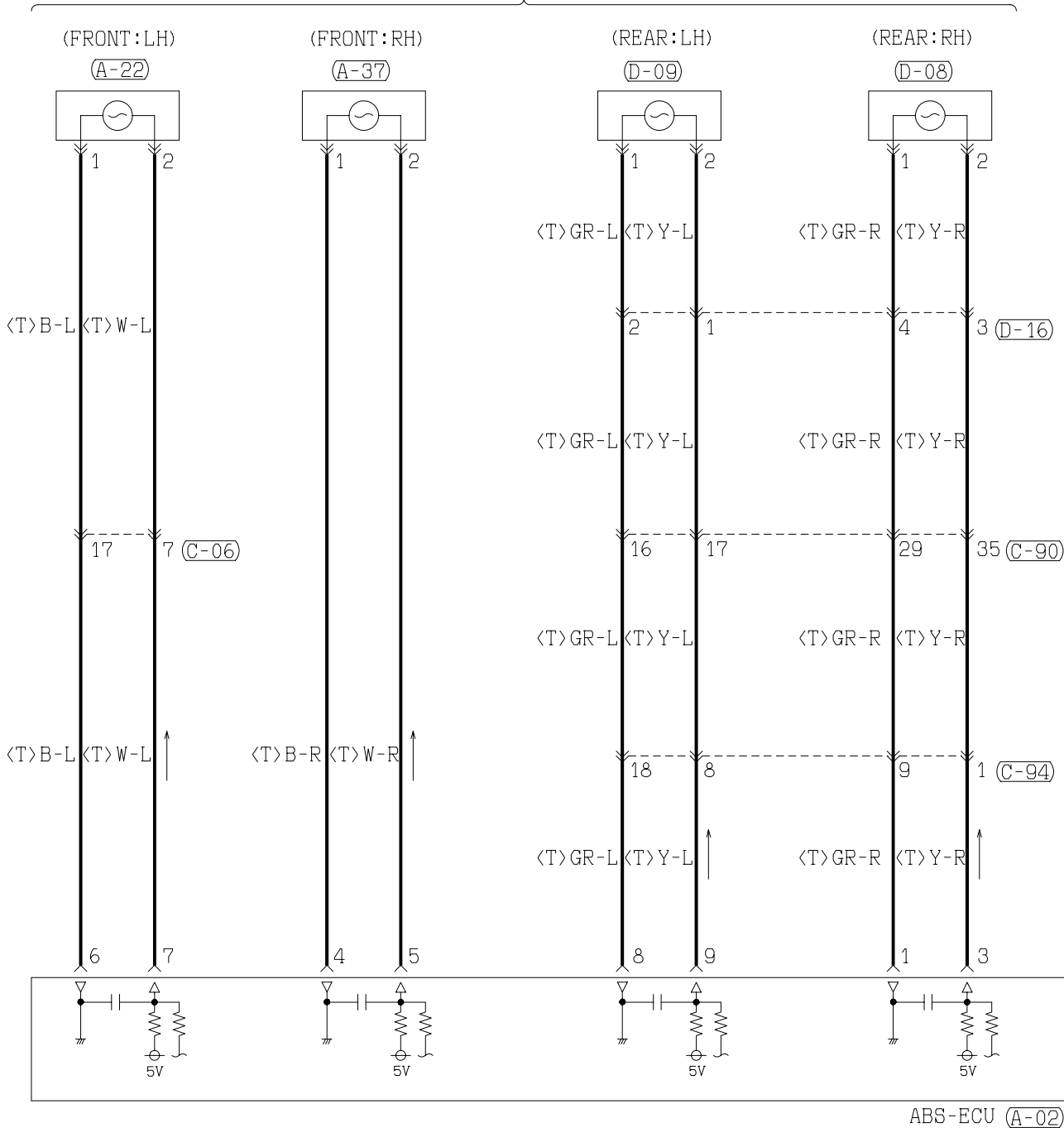

(A-02)

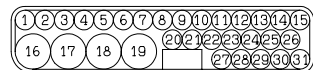

(A-22)



(A-37)



(C-06)

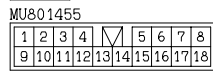

(C-29)

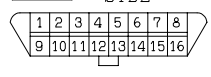

FRONT SIDE

(C-77)



(D-09)



(D-16)

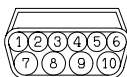

ABS-ECU (A-02)

TSB Revision

**4**

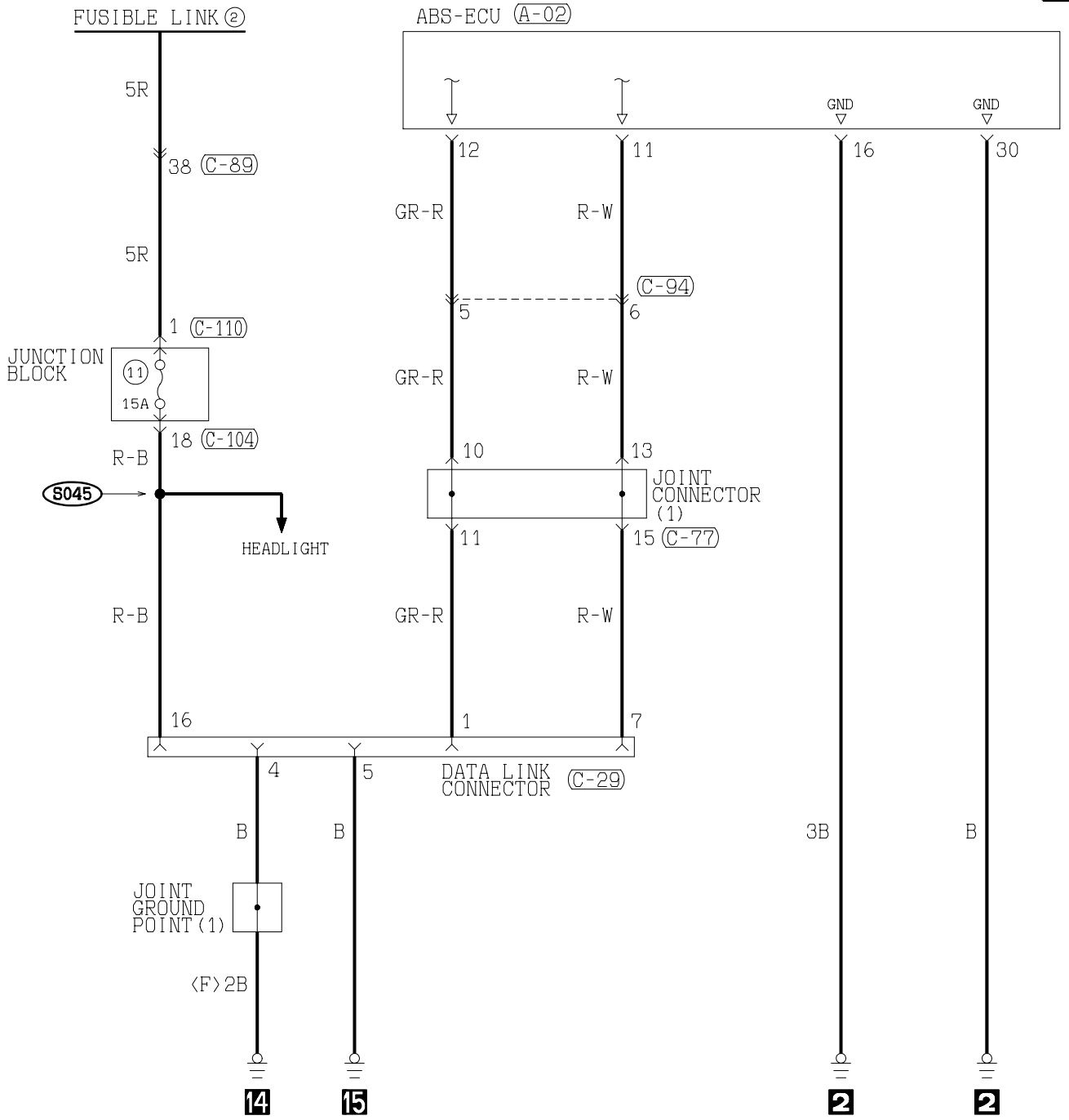

(C-89)

1	2	3	4	5	6	7	8	9	10	11	12	13
14	15	16	17	18	19	20	21	22	23	24	25	
26	27	28	29					30	31		38	
32	33	34		35		36	37					

(C-90)

1	2	3	4		5	6	7	8	9
10	11	12	13	14	15	16	17	18	19
20	21								
22	23	24	25	26	27	28	29	30	31
32	33				38	39	40	41	42
43									

(C-94)

MU801455

1	2	3	4	5	6	7	8
9	10	11	12	13	14	15	16
17	18						

(C-104)

MU801457

1	2	3	4	5	6	7	8	9
10	11	12	13	14	15	16	17	18
19	20							

(C-110)

1
---

(D-08)

MU802661

1	2
---	---

**WIRE COLOR CODE**  
 B : BLACK      BR: BROWN      G : GREEN      GR: GRAY  
 L : BLUE      LG: LIGHT GREEN      O : ORANGE      P : PINK  
 R : RED      SB: SKY BLUE      V : VIOLET      W : WHITE  
 Y : YELLOW

H1S15M36BB

**TSB Revision**

# SUPPLEMENTAL RESTRAINT SYSTEM (SRS) <VEHICLES WITHOUT SIDE AIR BAG>

M1901009700082

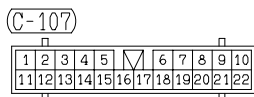
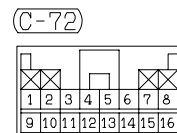
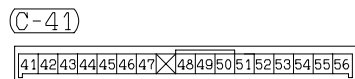
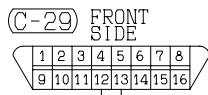
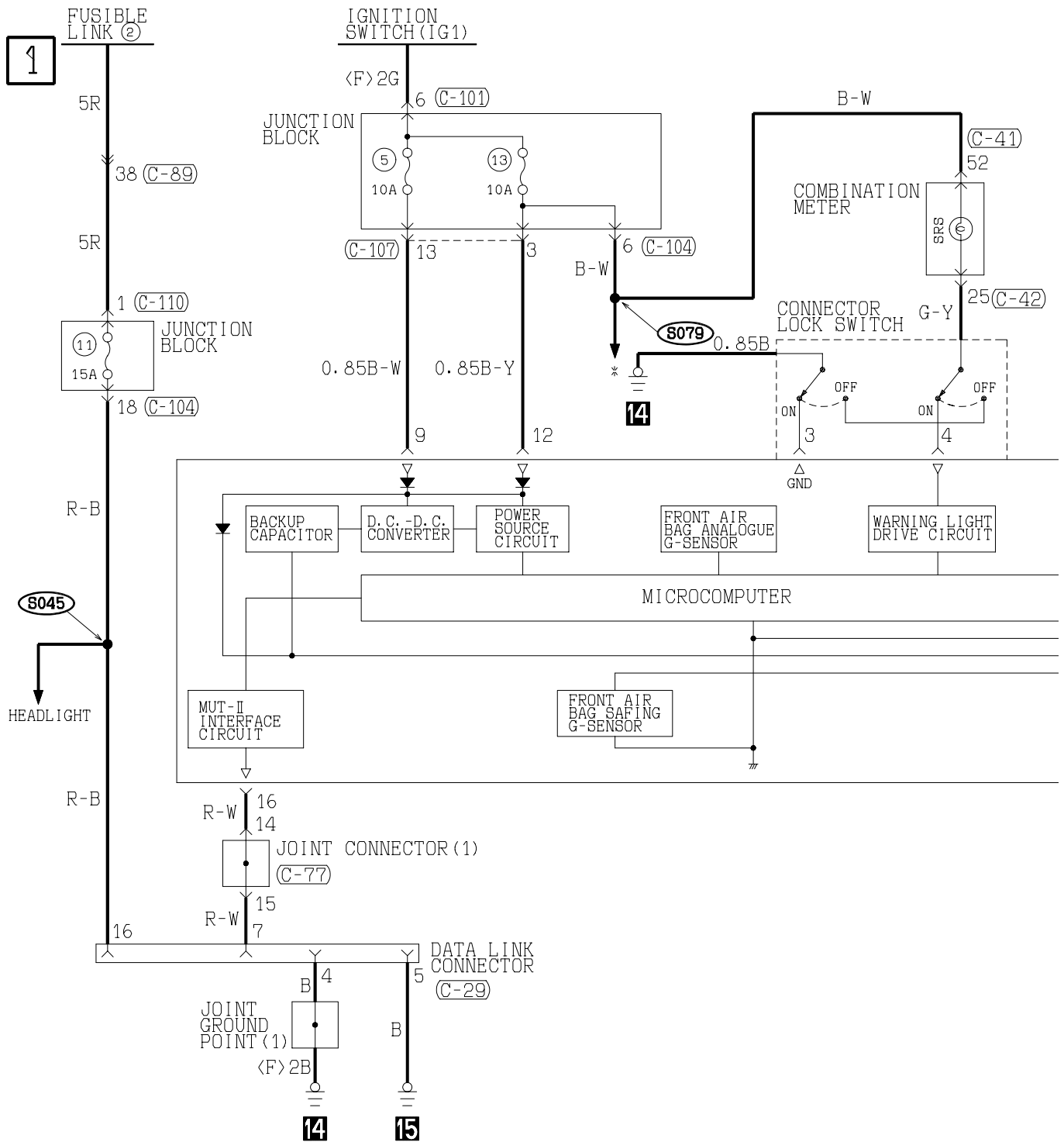

H1S15M37AA

TSB Revision

- NOTE
- \*: · AUTO-CRUISE CONTROL SYSTEM
  - FOG LIGHT
  - HEADLIGHT
  - INVECS-II 4A/T
  - METER AND GAUGE
  - MFI SYSTEM
  - MULTI CENTER DISPLAY
  - REAR WIPER AND WASHER
  - TAILLIGHT, POSITION LIGHT, REAR SIDE MARKER LIGHT AND LICENSE PLATE LIGHT
  - TURN-SIGNAL LIGHT AND HAZARD WARNING LIGHT

(CONNECTOR COUPLED: ON  
 (CONNECTOR UNCOUPLED: OFF)  
 CONNECTOR LOCK SWITCH

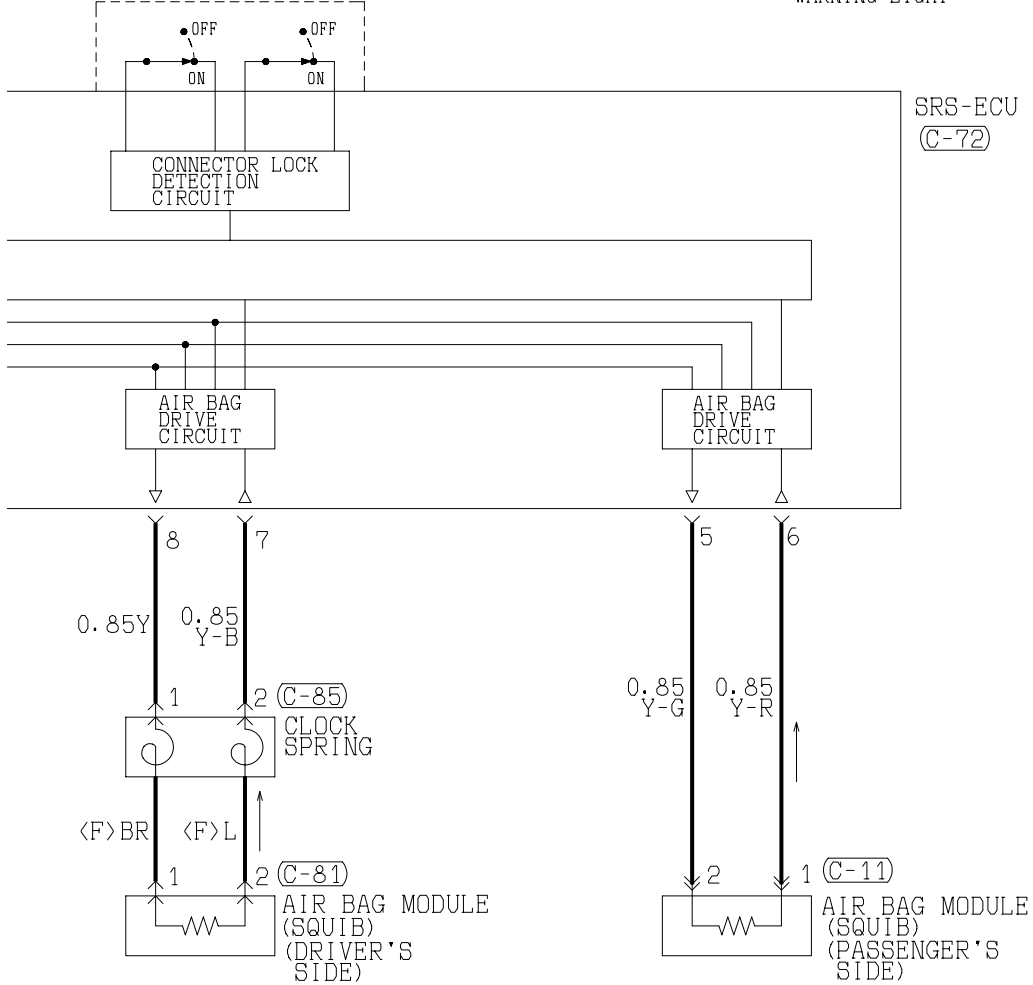

(C-77)

1	2	3	4	5	6	7	8	9	10	11
12	13	14	15	16	17	18	19	20	21	22
23	24	25	26	27	28	29	30	31	32	33

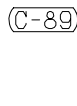
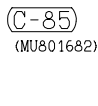

1	2	3	4	5	6	7	8	9	10	11	12	13
14	15	16	17	18	19	20	21	22	23	24	25	
26	27	28	29					30	31			38
32	33	34						36	37			



(C-104) (MU801457)

1	2	3	4	5	6	7	8	9		
10	11	12	13	14	15	16	17	18	19	20

WIRE COLOR CODE

B : BLACK	BR: BROWN	G : GREEN	GR: GRAY
L : BLUE	LG: LIGHT GREEN	O : ORANGE	P : PINK
R : RED	SB: SKY BLUE	V : VIOLET	W : WHITE
Y : YELLOW			

# SUPPLEMENTAL RESTRAINT SYSTEM (SRS) <VEHICLES WITH SIDE AIR BAG>

M1901009700093

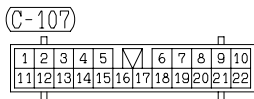
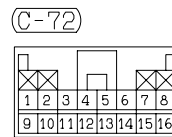
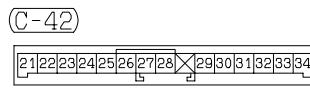
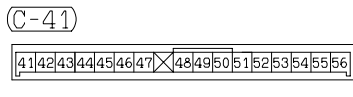
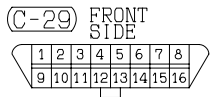
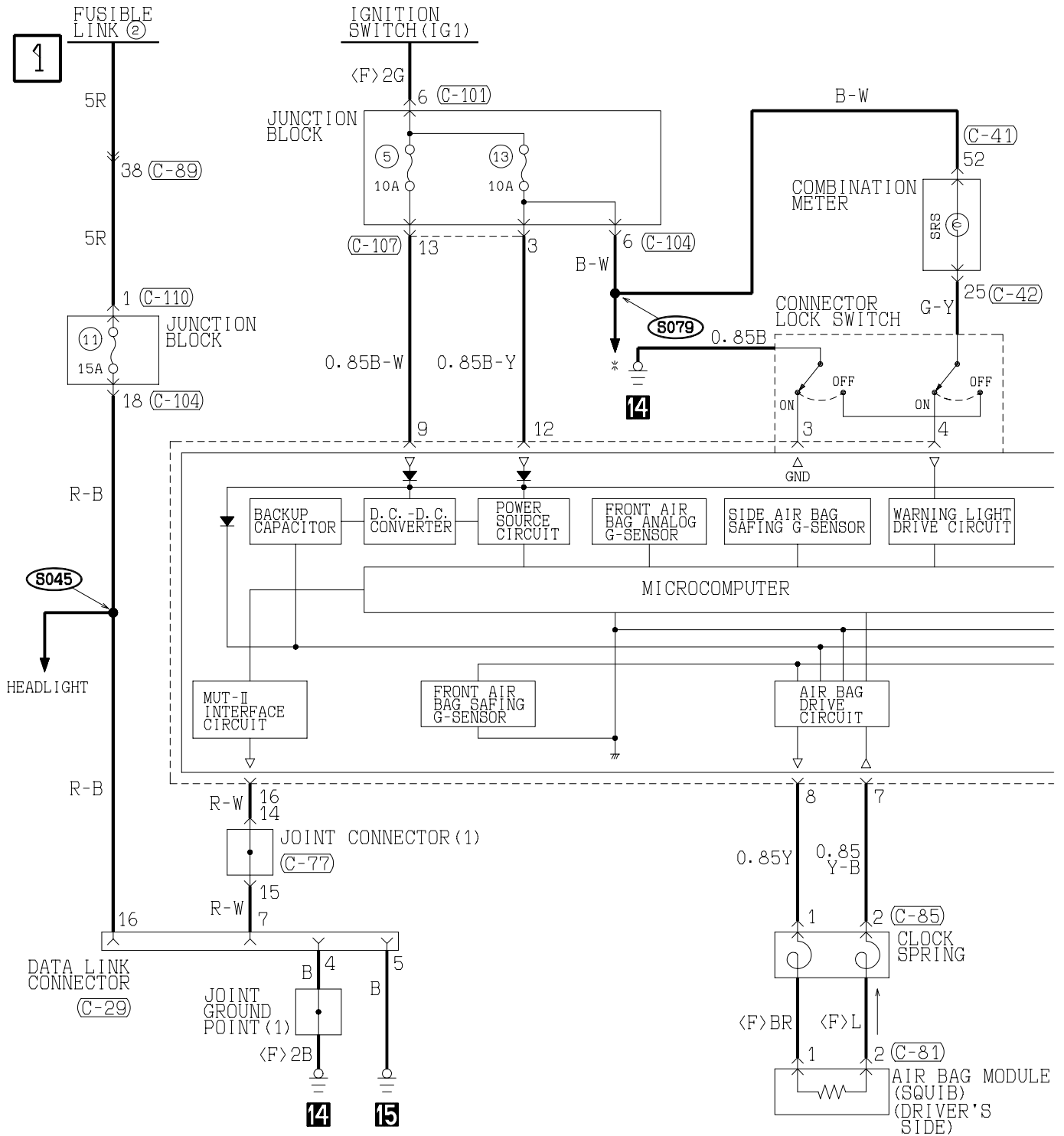

H1S15M38AA

2

- NOTE  
 \*: • AUTO-CRUISE CONTROL SYSTEM  
 • FOG LIGHT  
 • HEADLIGHT  
 • INVECS-II 4A/T  
 • METER AND GAUGE  
 • MFI SYSTEM  
 • MULTI CENTER DISPLAY  
 • REAR WIPER AND WASHER

- TAILLIGHT, POSITION LIGHT, REAR SIDE MARKER LIGHT AND LICENSE PLATE LIGHT  
 • TURN-SIGNAL LIGHT AND HAZARD WARNING LIGHT  
 • WINDSHIELD WIPER AND WASHER

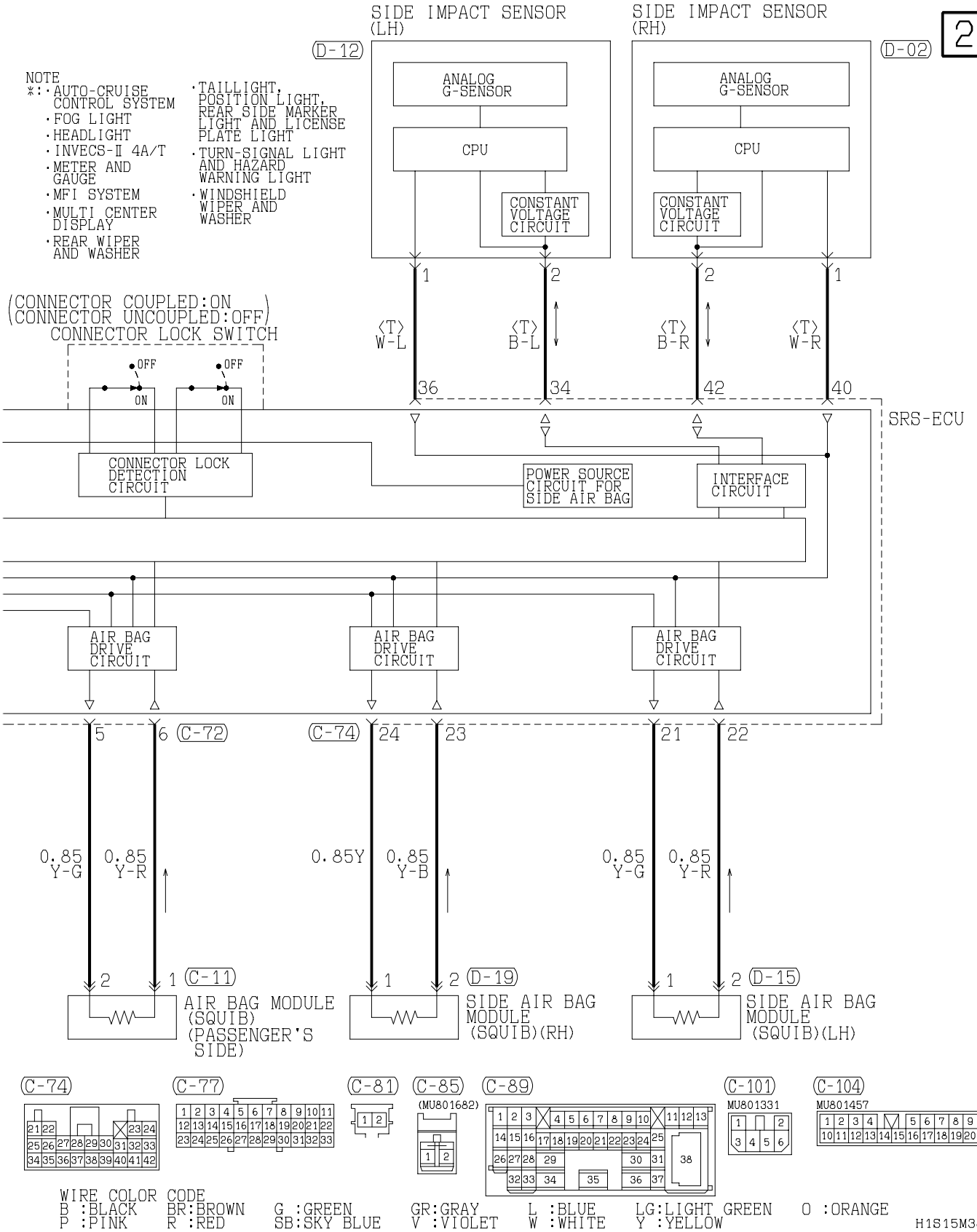

**TSB Revision**

# POWER SEAT

M1901010400052

1

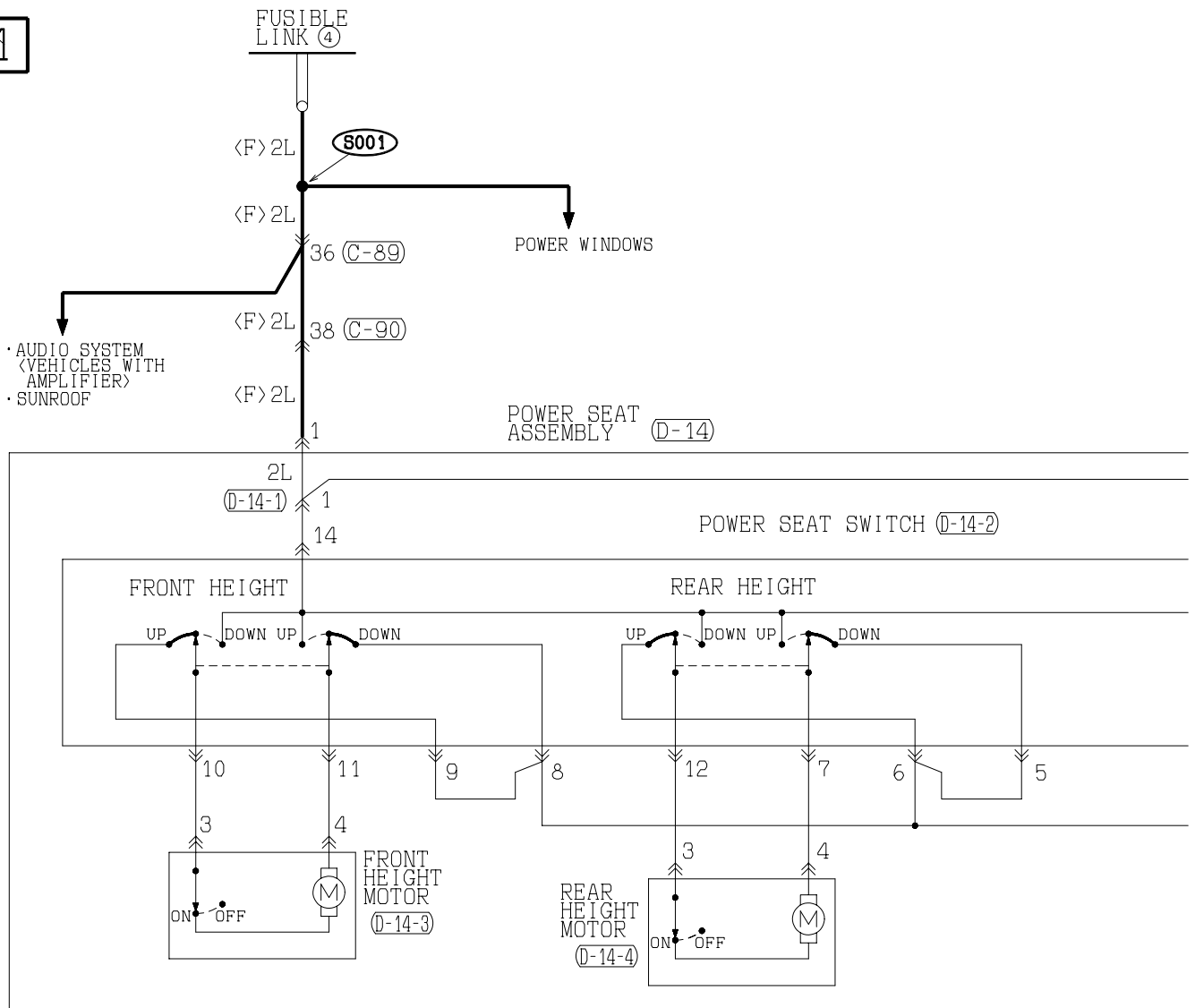

(C-89)

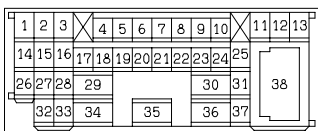

(C-90)

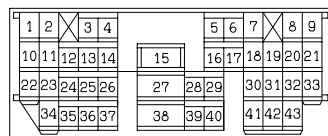

(D-14)



(D-14-1)



(D-14-2)



(D-14-3)



(D-14-4)



(D-14-5)



H1S15M43AA

TSB Revision



2

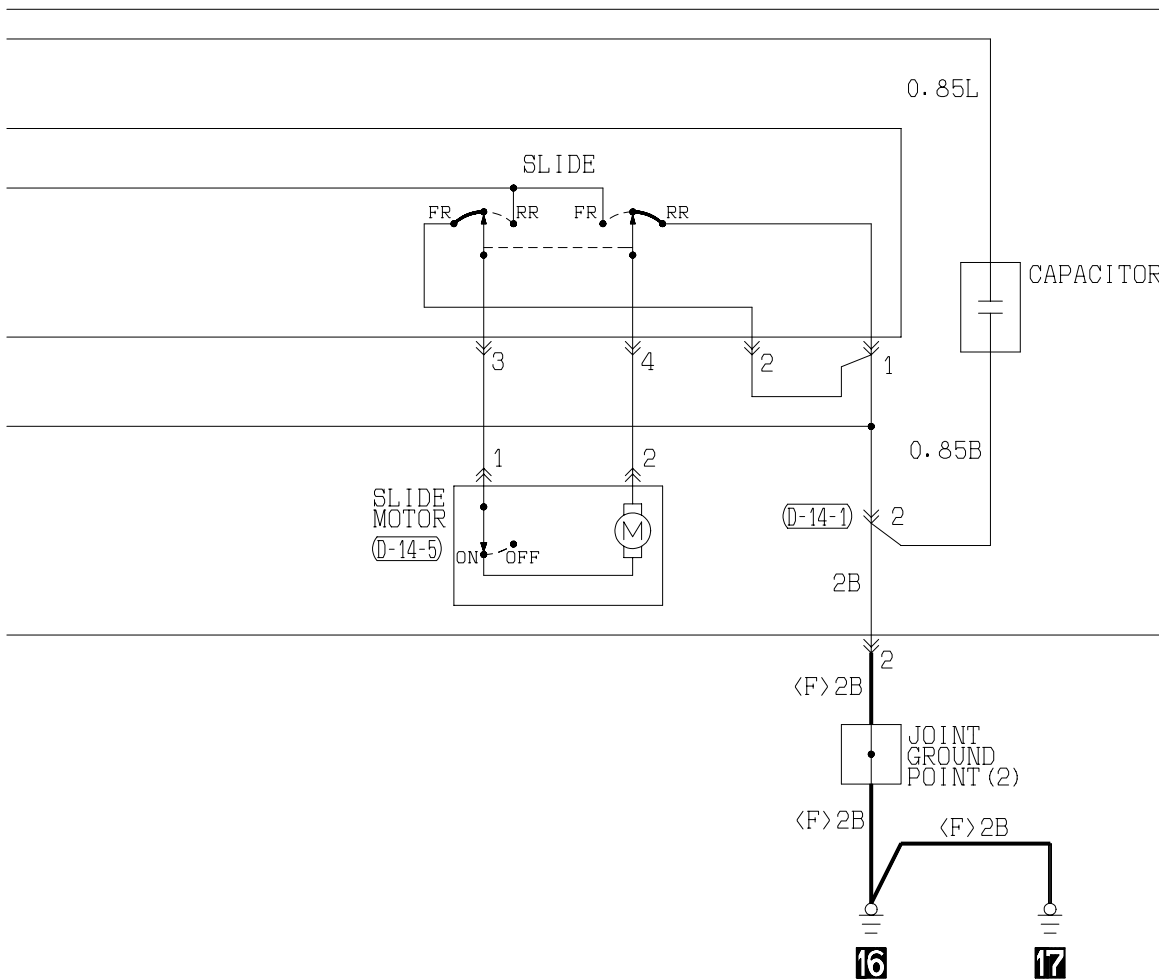

WIRE COLOR CODE  
 B : BLACK BR : BROWN G : GREEN GR : GRAY L : BLUE LG : LIGHT GREEN O : ORANGE  
 P : PINK R : RED SB : SKY BLUE V : VIOLET W : WHITE Y : YELLOW

H1S15M43AB

TSB Revision

# THEFT-ALARM SYSTEM

1

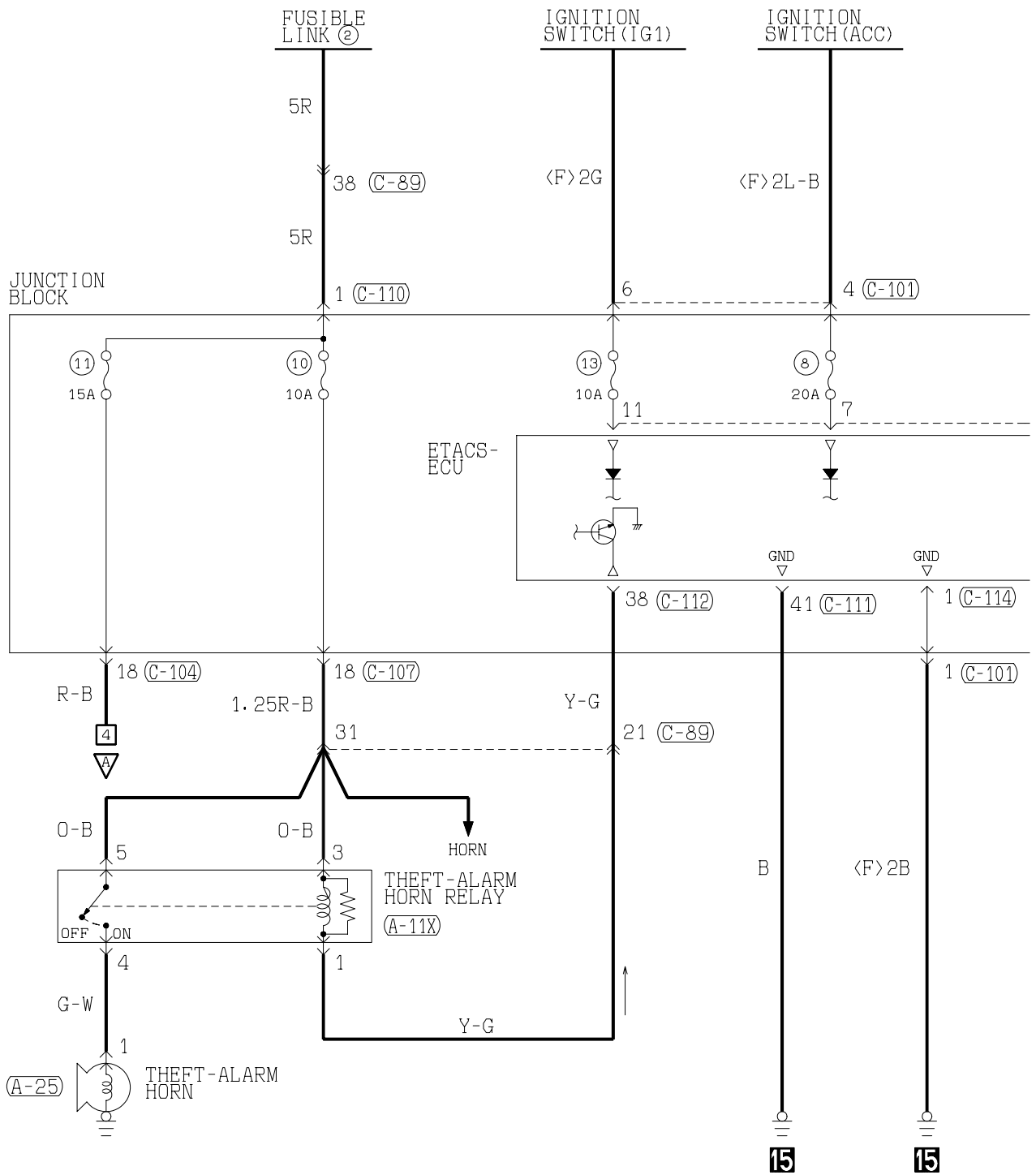

(A-11X)



(A-25)



(C-42)

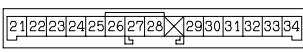

(C-78)



(C-88)

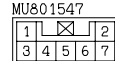

(C-89)

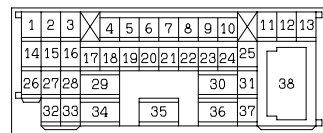

(C-112)

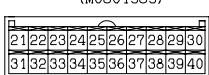

(C-114)

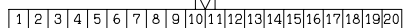

TSB Revision

2

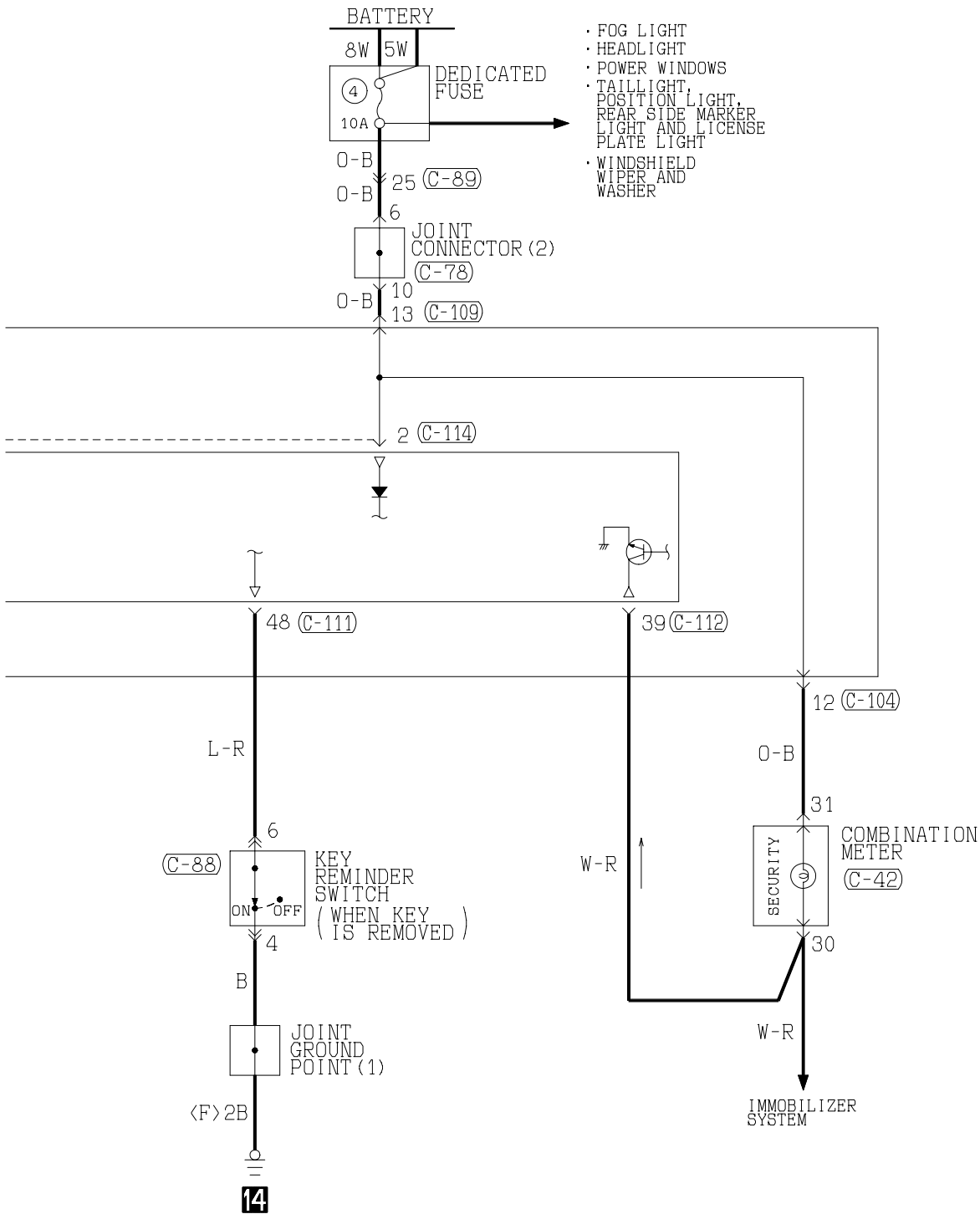

(C-101)  
MU801331



(C-104)  
MU801457

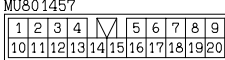

(C-107)

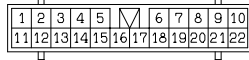

(C-109)

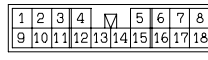

(C-110)



(C-111) (MU801584)

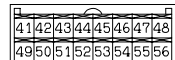

WIRE COLOR CODE

B : BLACK    LG: LIGHT GREEN    G : GREEN    L : BLUE    W : WHITE    Y : YELLOW    SB: SKY BLUE  
BR: BROWN    O : ORANGE    GR: GRAY    R : RED    P : PINK    V : VIOLET

H1S15M49AB

TSB Revision

THEFT-ALARM SYSTEM (CONTINUED)

3

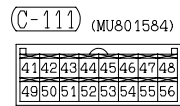
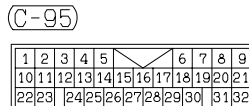
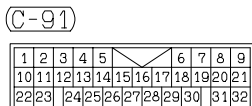
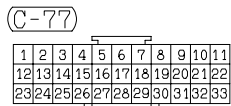
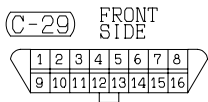
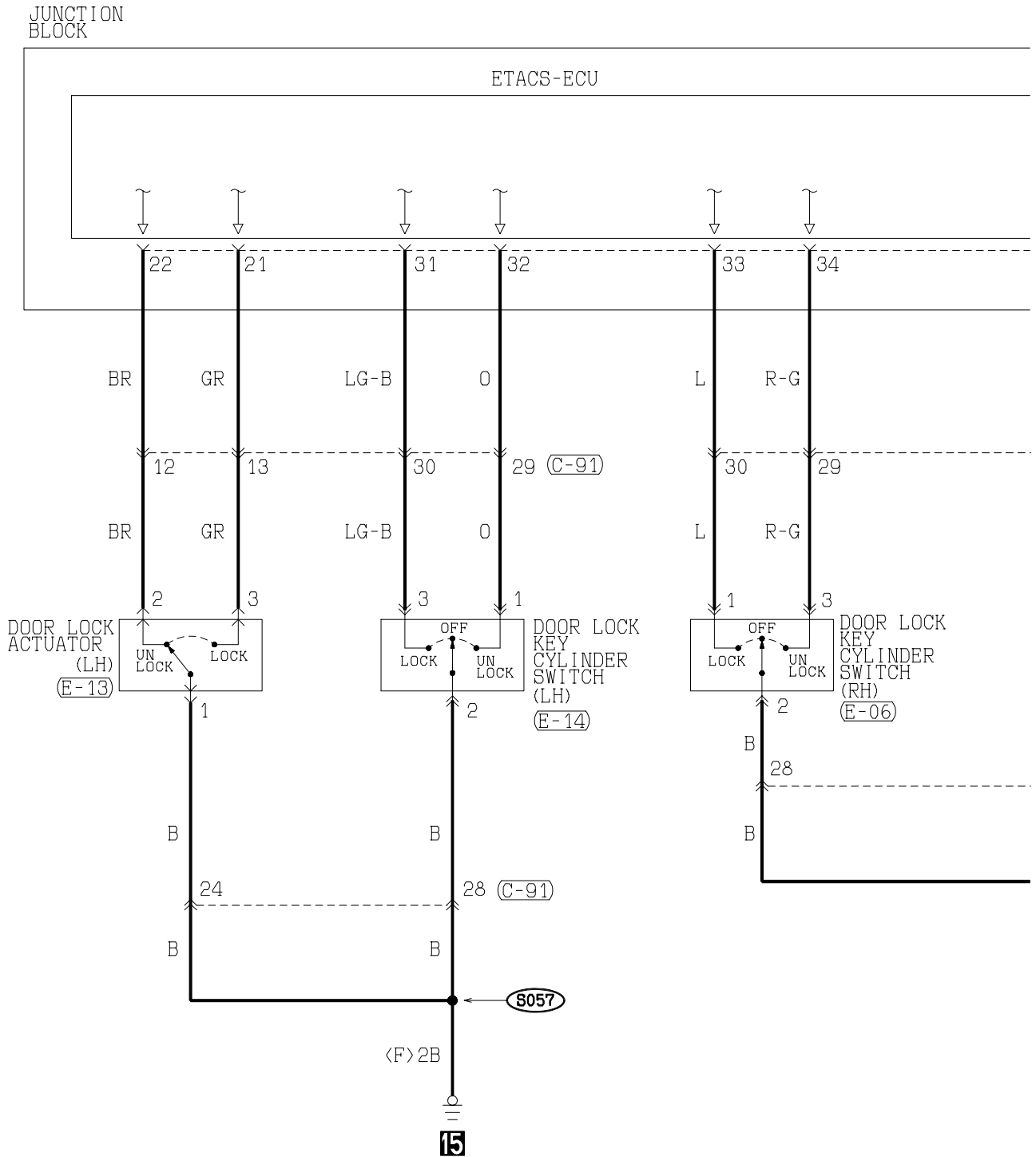

TSB Revision

4

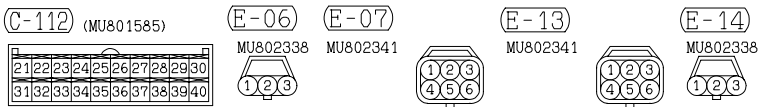
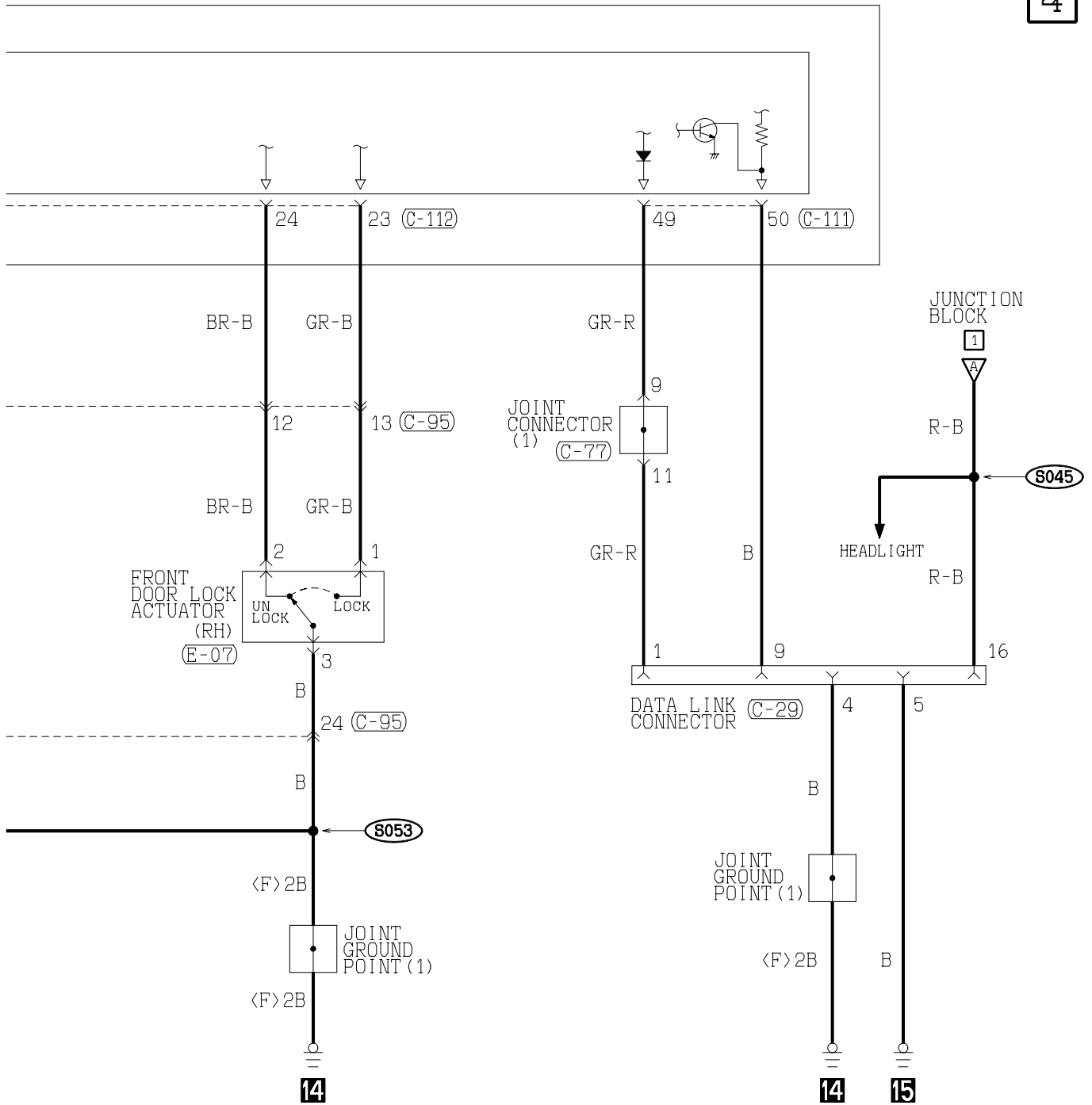

WIRE COLOR CODE  
 B : BLACK BR : BROWN G : GREEN GR : GRAY L : BLUE LG : LIGHT GREEN O : ORANGE  
 P : PINK R : RED SB : SKY BLUE V : VIOLET W : WHITE Y : YELLOW

H1S15M49BB

TSB Revision

THEFT-ALARM SYSTEM (CONTINUED)

5

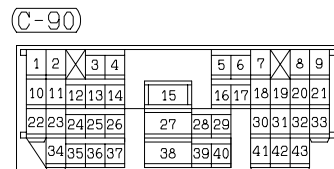
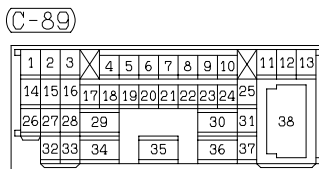
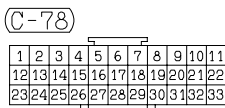
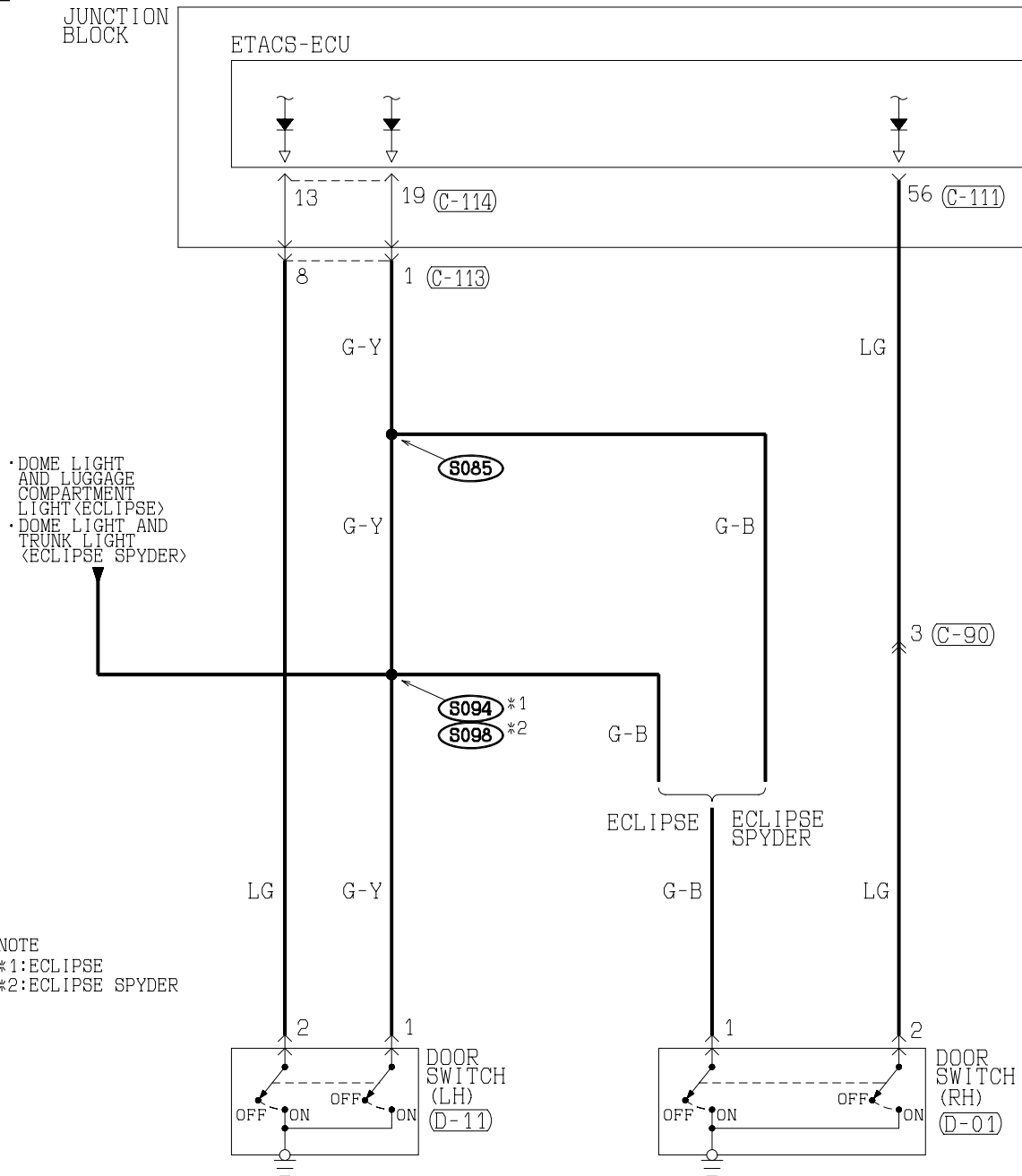

6

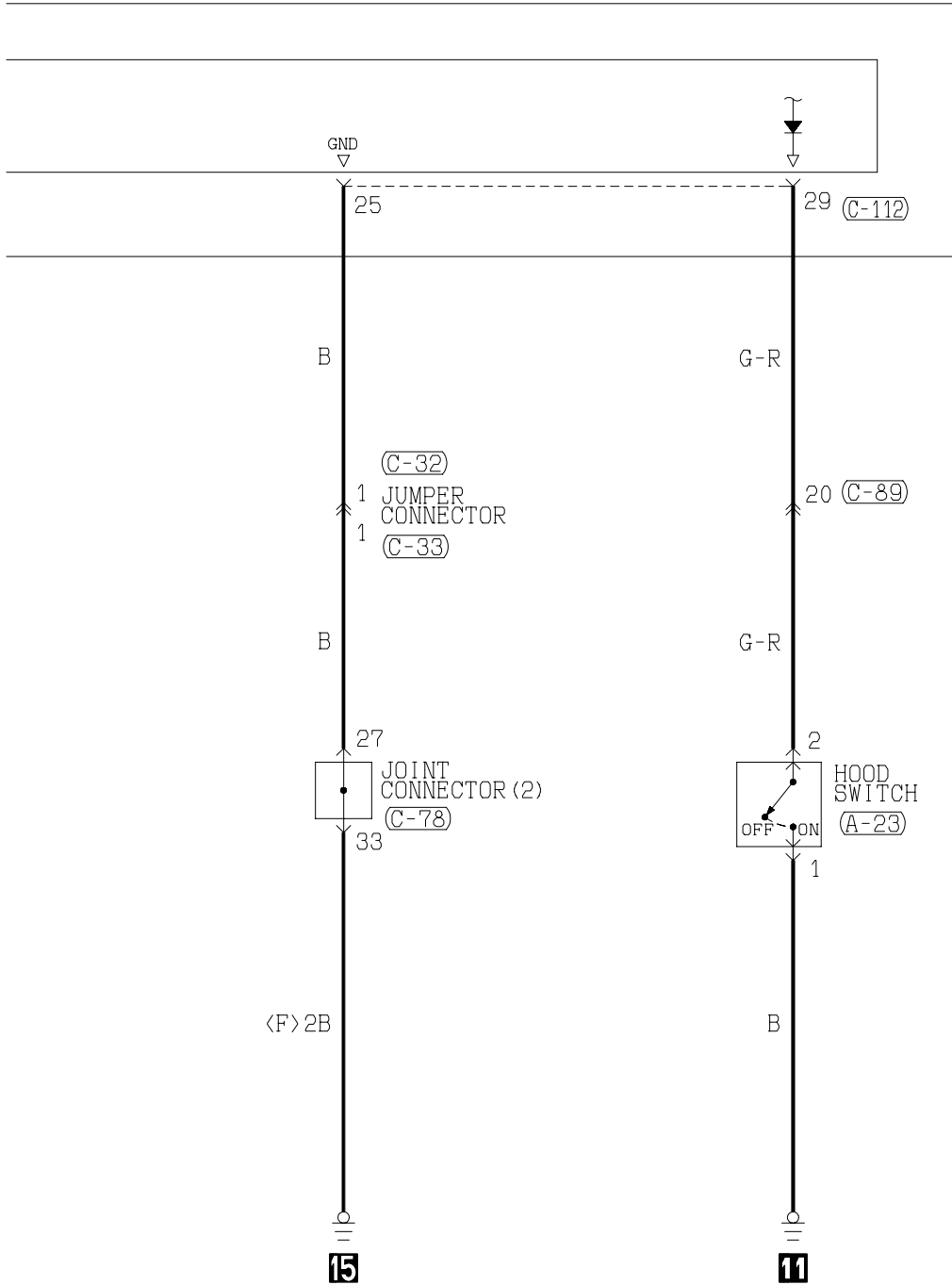

(C-111) (MU801584)

41	42	43	44	45	46	47	48
49	50	51	52	53	54	55	56

(C-112) (MU801585)

21	22	23	24	25	26	27	28	29	30
31	32	33	34	35	36	37	38	39	40

(C-113)

1	2	3	4	5	6	7	8	9	
10	11	12	13	14	15	16	17	18	19

(C-114)

1	2	3	4	5	6	7	8	9	10	11	12	13	14	15	16	17	18	19	20
---	---	---	---	---	---	---	---	---	----	----	----	----	----	----	----	----	----	----	----

(D-01)

1	2	3
---	---	---

(D-11)

1	2	3
---	---	---

WIRE COLOR CODE

B : BLACK BR : BROWN G : GREEN GR : GRAY L : BLUE LG : LIGHT GREEN O : ORANGE  
P : PINK R : RED SB : SKY BLUE V : VIOLET W : WHITE Y : YELLOW

H1S15M49CB

TSB Revision

THEFT-ALARM SYSTEM (CONTINUED)

7

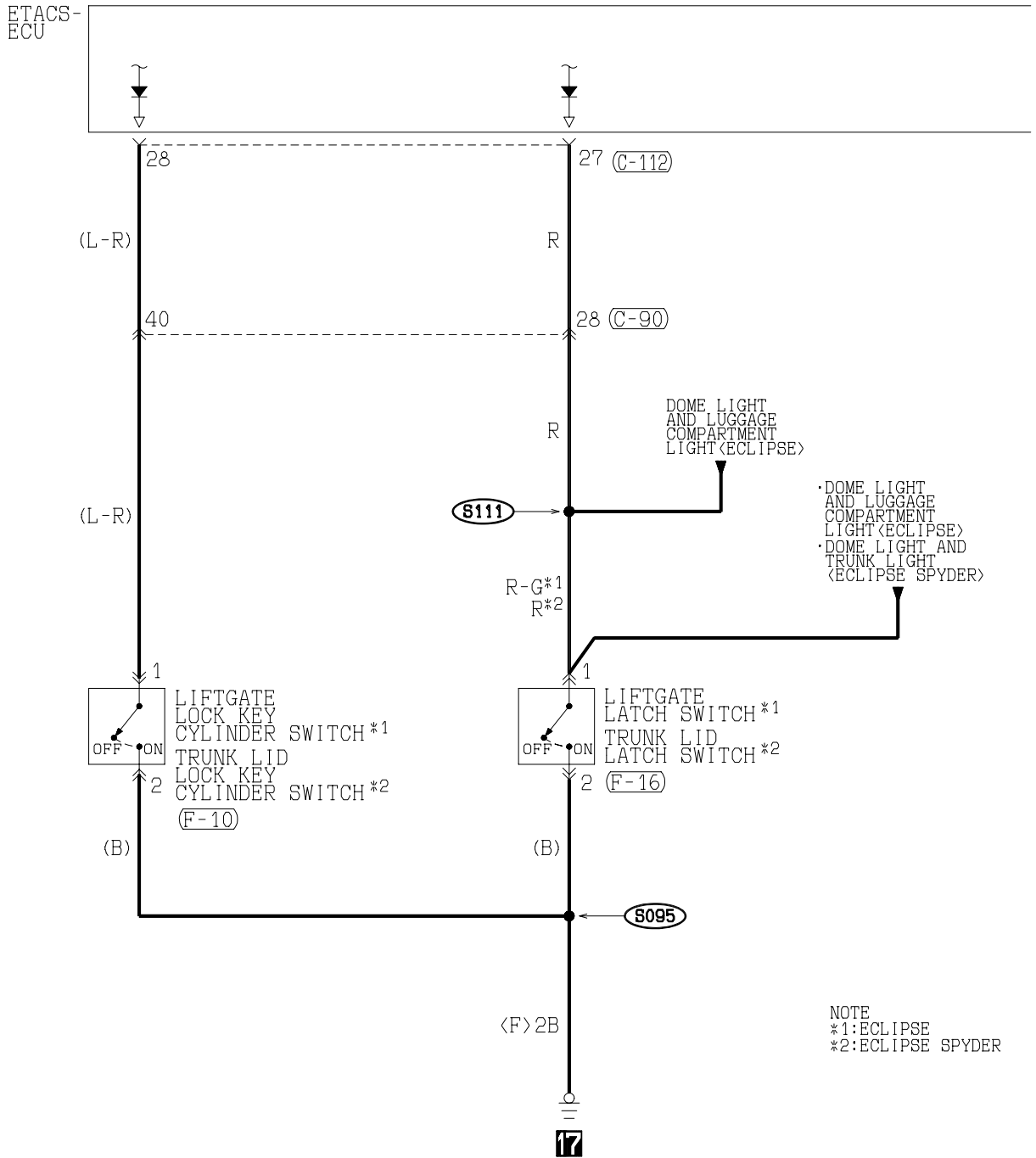

(A-07X)



(A-09X)

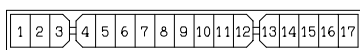

(A-24)



(A-35)



(C-06)

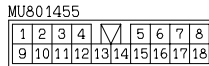

(C-78)



TSB Revision



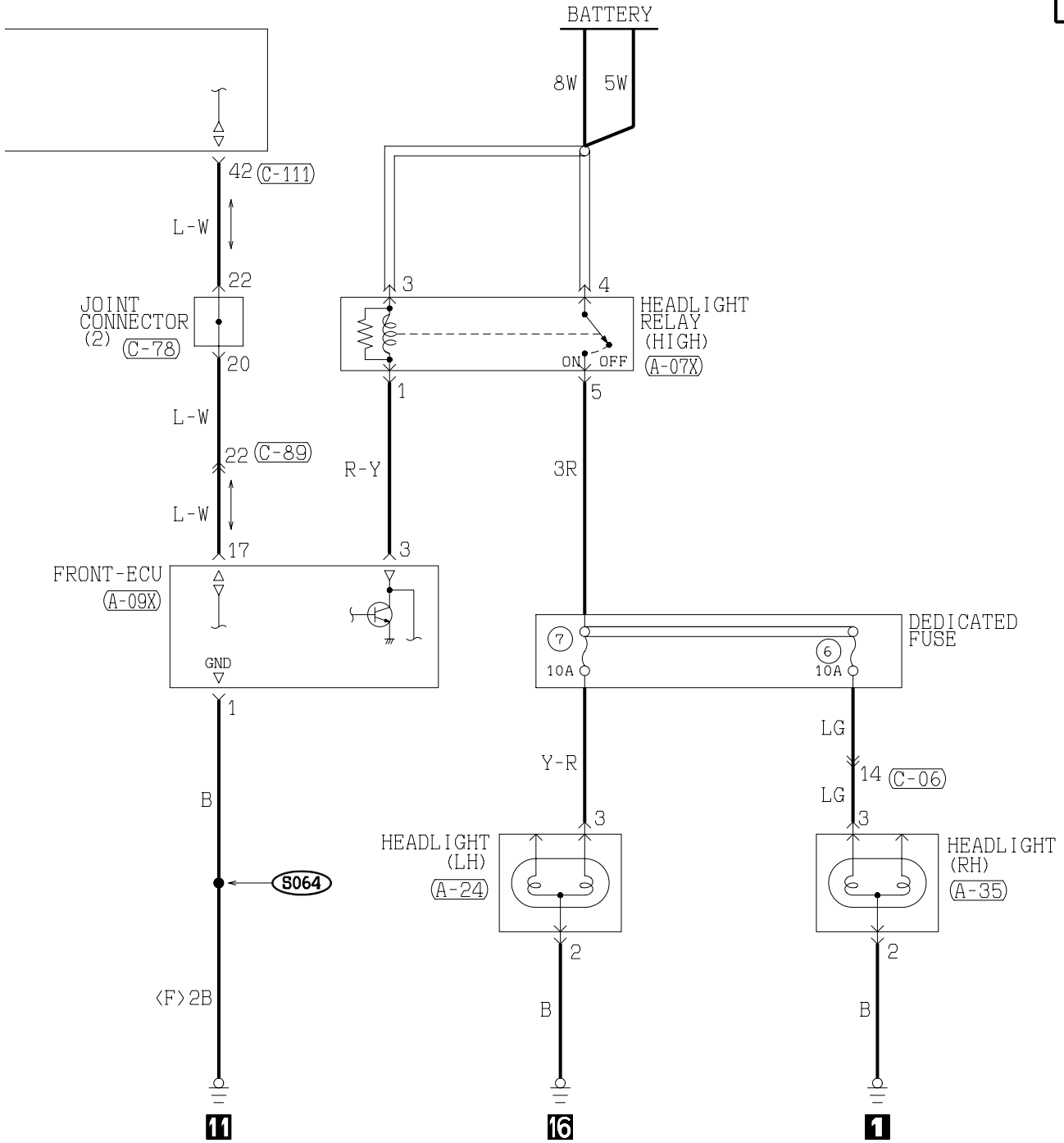

(C-89)

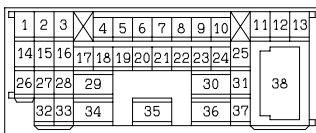

(C-90)

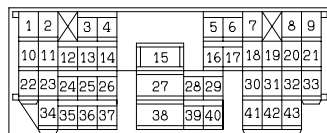

(C-111) (MU801584)



(C-112) (MU801585)

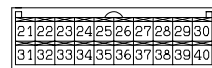

(F-10)



(F-16)



# FORGOTTEN KEY PREVENTION FUNCTION

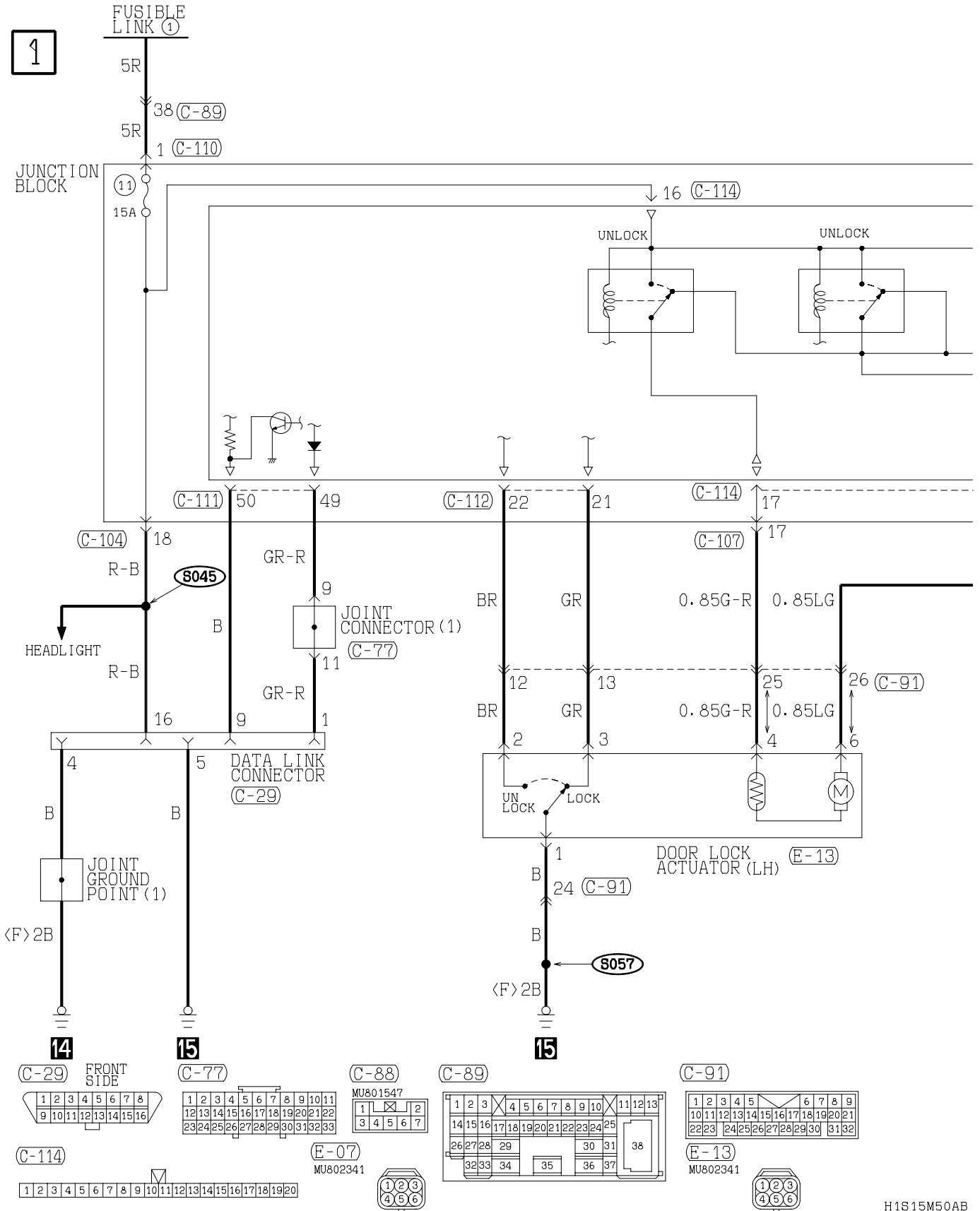

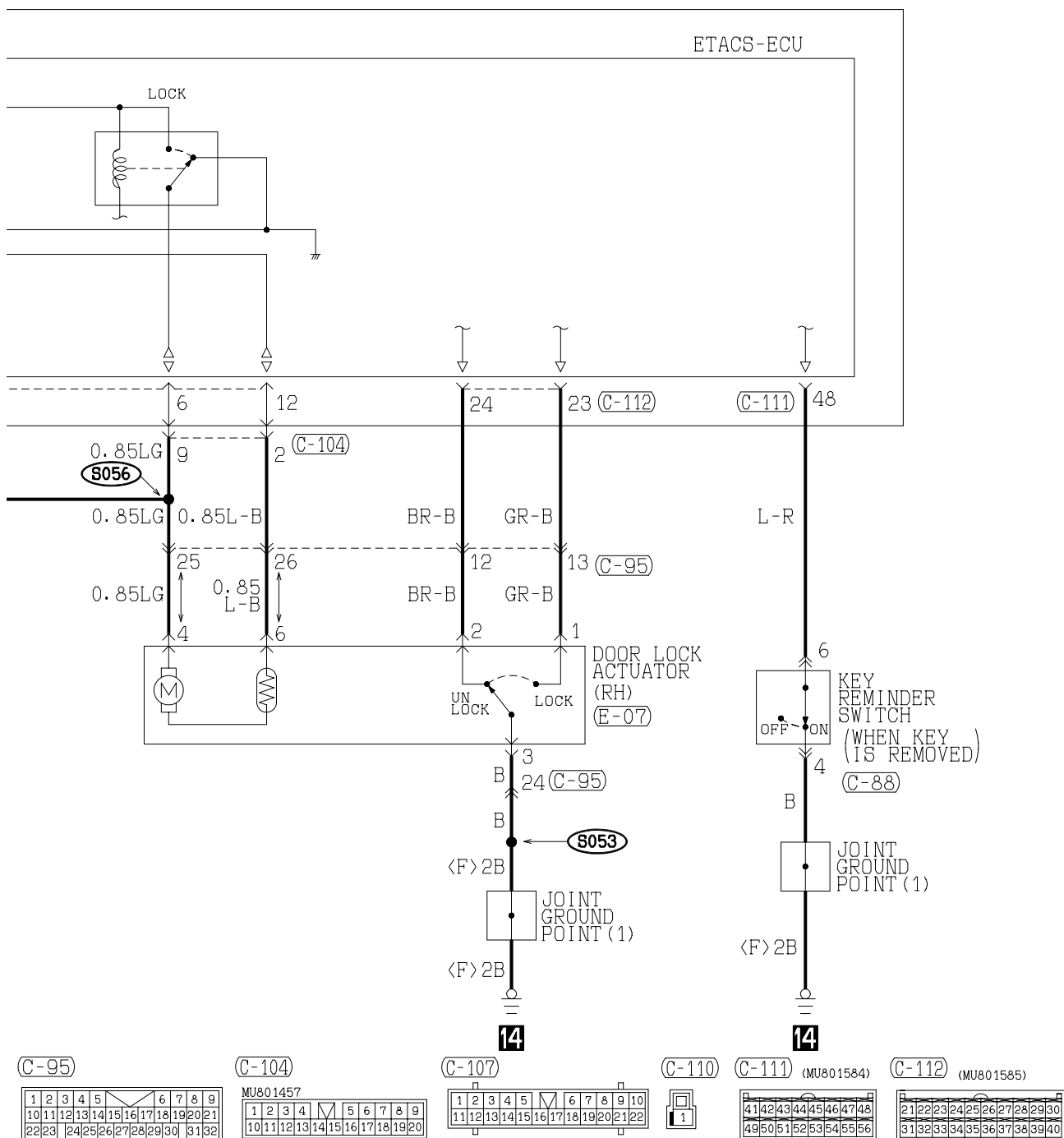

WIRE COLOR CODE  
 B : BLACK BR: BROWN G : GREEN GR: GRAY L : BLUE LG: LIGHT GREEN O : ORANGE  
 P : PINK R : RED SB: SKY BLUE V : VIOLET W : WHITE Y : YELLOW

H1S15M50AB

TSB Revision

FORGOTTEN KEY PREVENTION FUNCTION (CONTINUED)

3

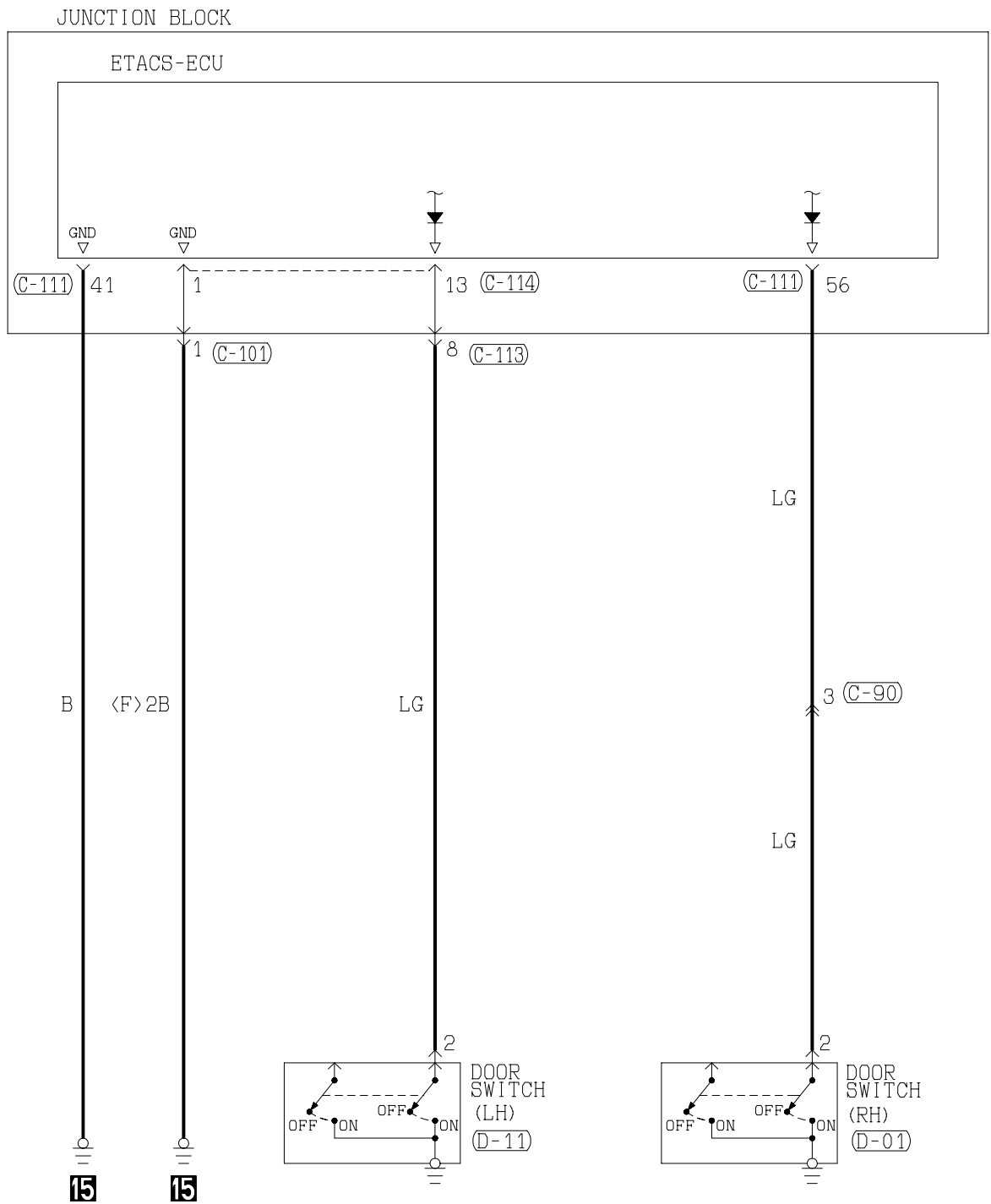

(C-90)

1	2	3	4	5	6	7	8	9
10	11	12	13	14	15	16	17	18
19	20	21	22	23	24	25	26	27
28	29	30	31	32	33	34	35	36
37	38	39	40	41	42	43		

(C-101)

1	2
3	4
5	6

(C-111) (MU801584)

41	42	43	44	45	46	47	48
49	50	51	52	53	54	55	56

(C-113)

1	2	3	4	5	6	7	8	9
10	11	12	13	14	15	16	17	18
19								

(C-114)

1	2	3	4	5	6	7	8	9	10	11	12	13	14	15	16	17	18	19	20
---	---	---	---	---	---	---	---	---	----	----	----	----	----	----	----	----	----	----	----

(D-01)

1	2	3
---	---	---

(D-11)

1	2	3
---	---	---

TSB Revision

NOTES

TSB Revision

# LIGHTING MONITOR TONE ALARM

M1901011400066

1

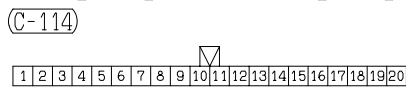
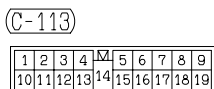
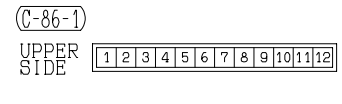
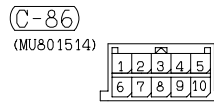
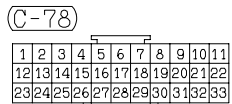
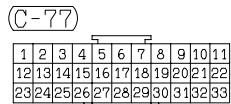
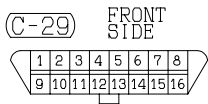
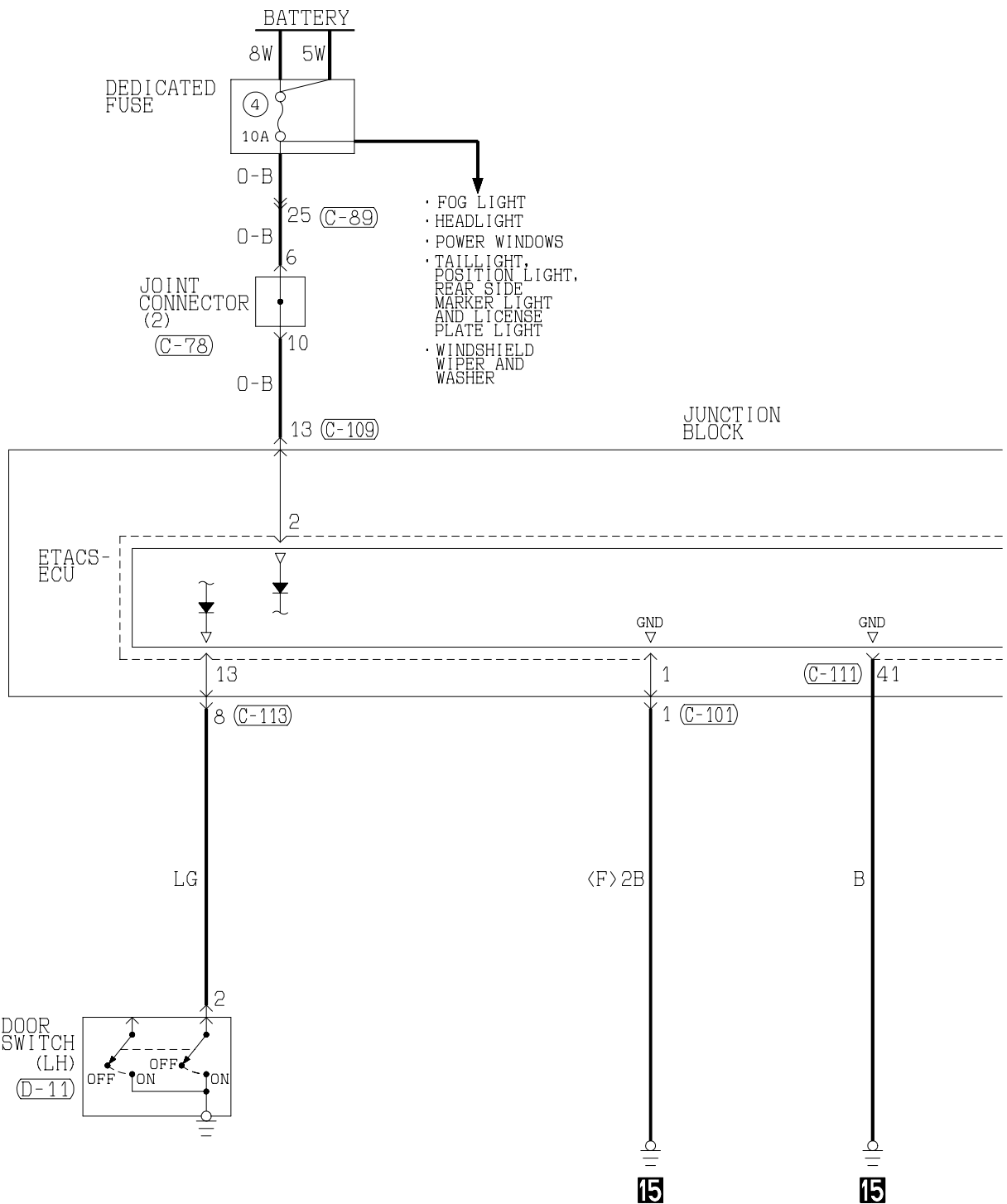

H1S15M46AA

TSB Revision

2

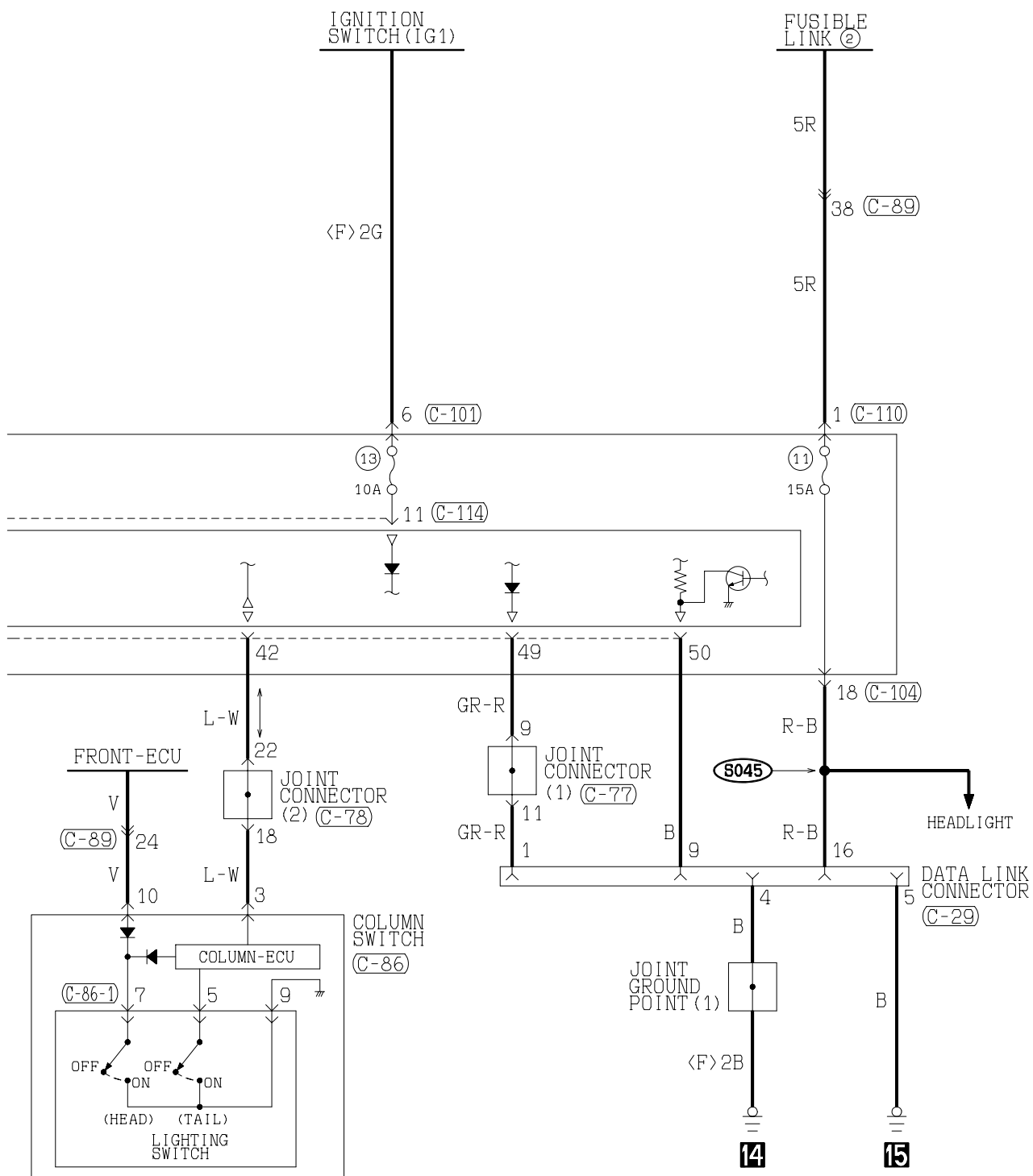

(C-89)

1	2	3	4	5	6	7	8	9	10	11	12	13
14	15	16	17	18	19	20	21	22	23	24	25	38
26	27	28	29			30	31					
32	33	34		35		36	37					

(C-101)

MU801331

1	2
3	4
5	6

(C-104)

MU801457

1	2	3	4	5	6	7	8	9
10	11	12	13	14	15	16	17	18
19	20							

(C-109)

1	2	3	4	5	6	7	8
9	10	11	12	13	14	15	16
17	18						

(C-110)

1
---

(C-111)

(MU801584)

41	42	43	44	45	46	47	48
49	50	51	52	53	54	55	56

WIRE COLOR CODE  
 B : BLACK      LG : LIGHT GREEN      G : GREEN      L : BLUE  
 BR : BROWN    O : ORANGE                      GR : GRAY      R : RED  
 W : WHITE      SB : SKY BLUE                      P : PINK        Y : YELLOW  
 V : VIOLET

H1S15M46AB

TSB Revision

# KEY REMINDER TONE ALARM

M1901011300069

1

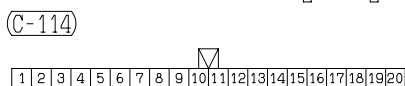
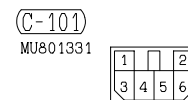
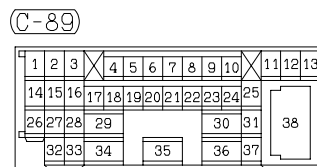
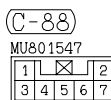
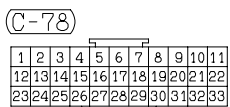
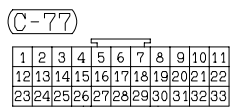
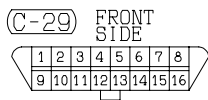
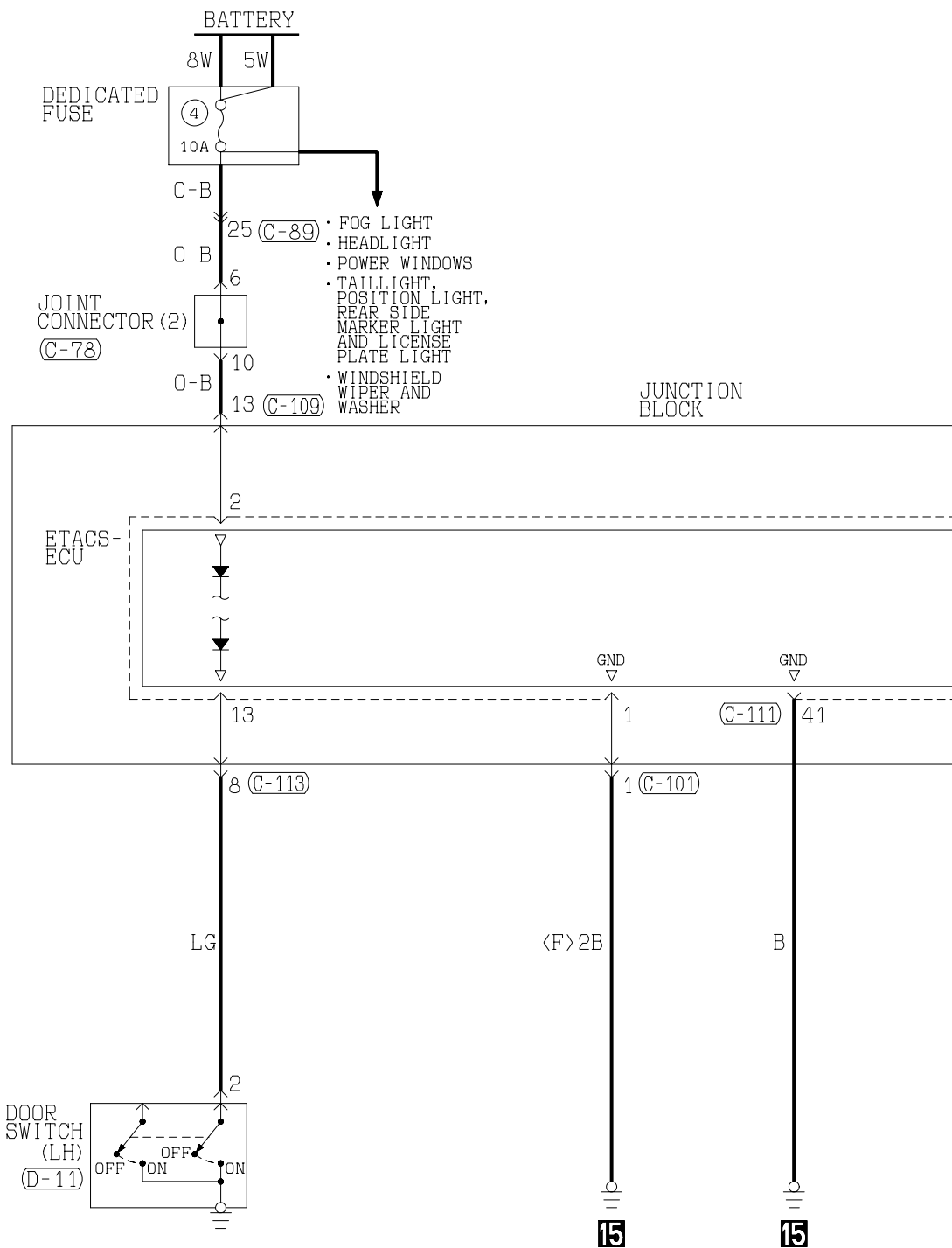

H1515M47AA

TSB Revision



2

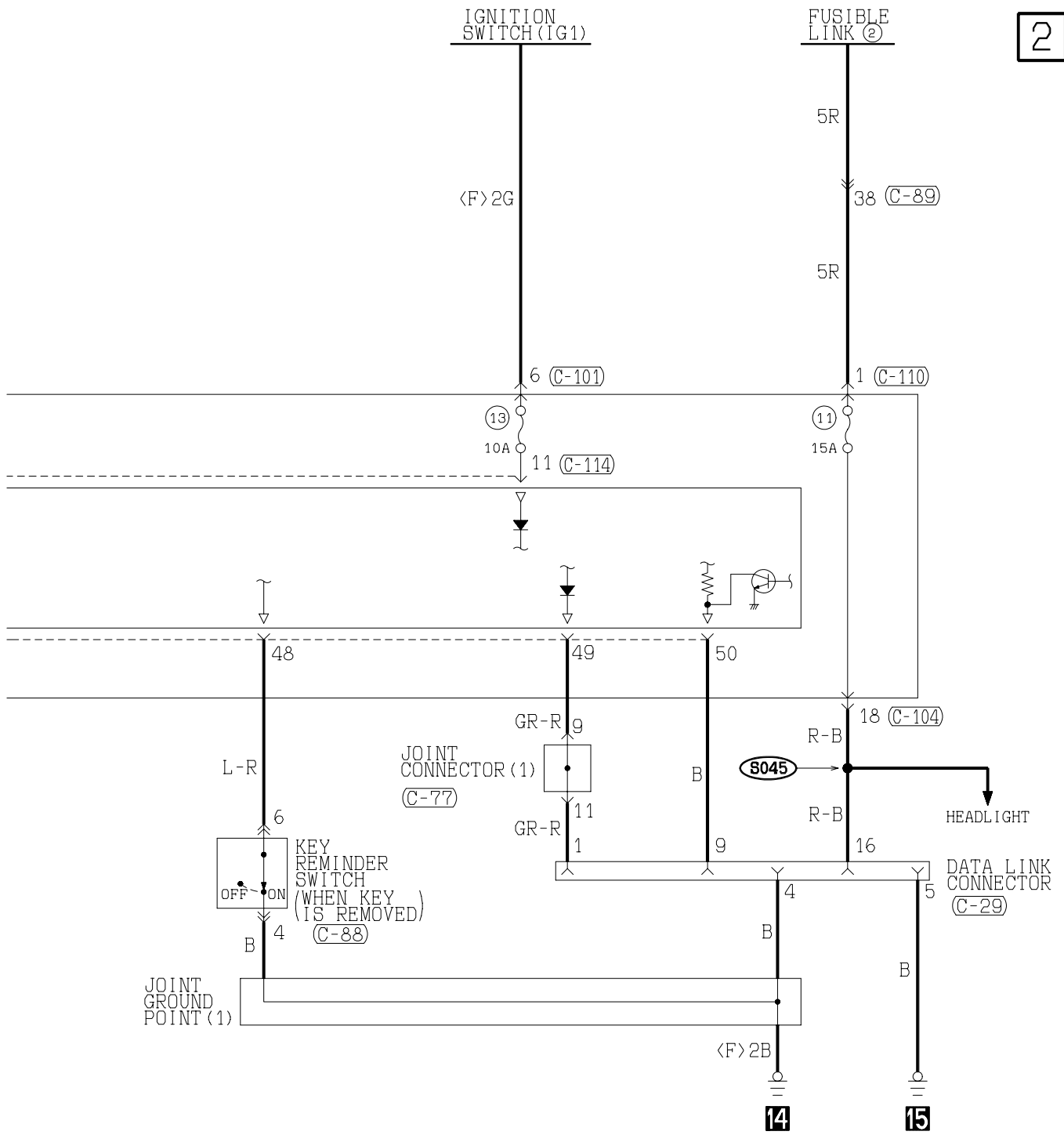

(C-104)

MU801457

1	2	3	4	M	5	6	7	8	9	
10	11	12	13	14	15	16	17	18	19	20

(C-109)

1	2	3	4	M	5	6	7	8	
9	10	11	12	13	14	15	16	17	18

(C-110)

1
---

(C-111) (MU801584)

41	42	43	44	45	46	47	48
49	50	51	52	53	54	55	56

(C-113)

1	2	3	4	M	5	6	7	8	9
10	11	12	13	14	15	16	17	18	19

WIRE COLOR CODE  
 B : BLACK BR : BROWN G : GREEN GR : GRAY L : BLUE LG : LIGHT GREEN O : ORANGE  
 P : PINK R : RED SB : SKY BLUE V : VIOLET W : WHITE Y : YELLOW

H1S15M47AB

TSB Revision

# SEAT BELT TONE ALARM

1

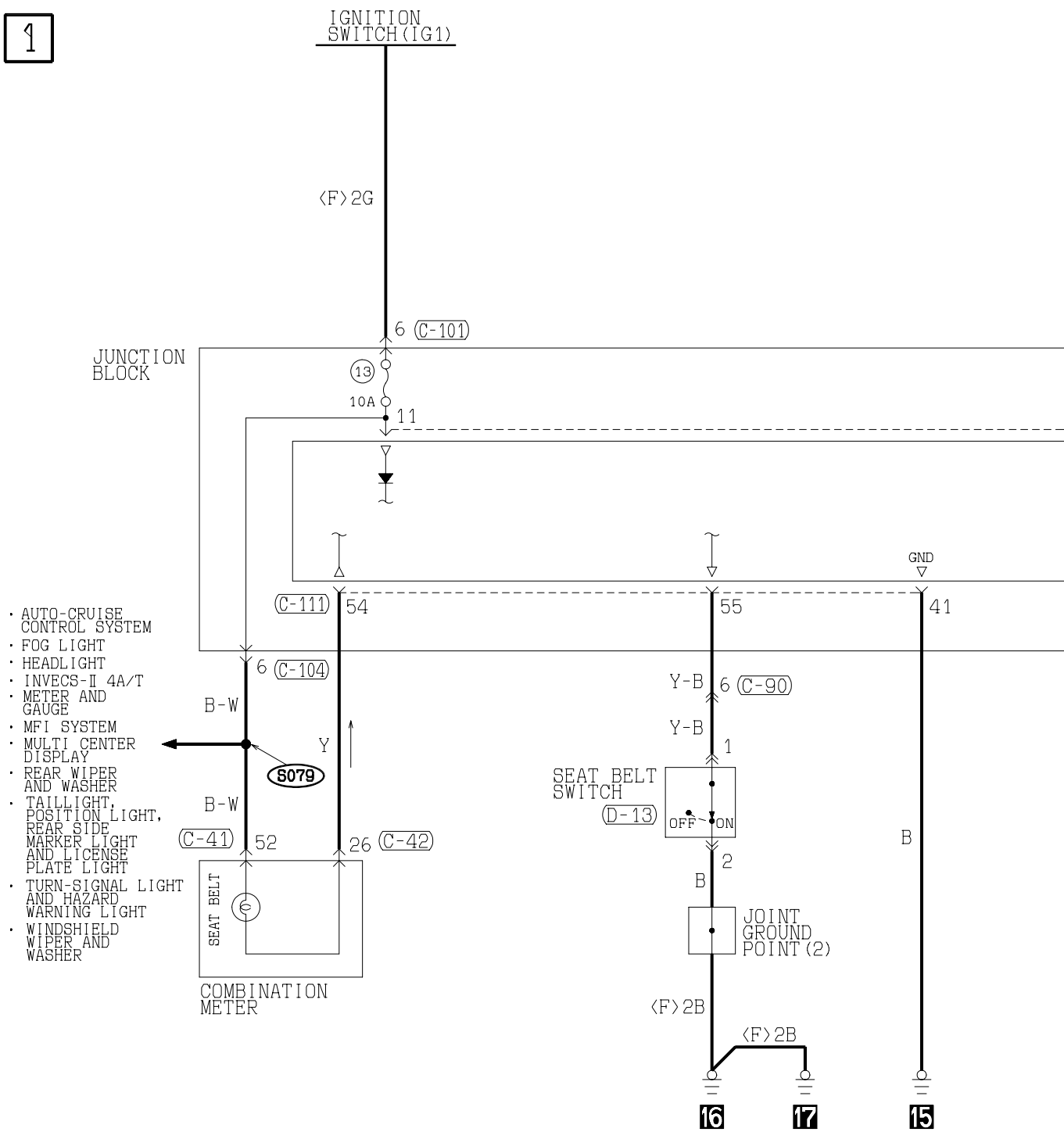

(C-29) FRONT SIDE

1	2	3	4	5	6	7	8
9	10	11	12	13	14	15	16

(C-41)

41	42	43	44	45	46	47	48	49	50	51	52	53	54	55	56
----	----	----	----	----	----	----	----	----	----	----	----	----	----	----	----

(C-42)

21	22	23	24	25	26	27	28	29	30	31	32	33	34
----	----	----	----	----	----	----	----	----	----	----	----	----	----

(C-77)

1	2	3	4	5	6	7	8	9	10	11
12	13	14	15	16	17	18	19	20	21	22
23	24	25	26	27	28	29	30	31	32	33

(C-78)

1	2	3	4	5	6	7	8	9	10	11
12	13	14	15	16	17	18	19	20	21	22
23	24	25	26	27	28	29	30	31	32	33

(C-111) (MU801584)

41	42	43	44	45	46	47	48
49	50	51	52	53	54	55	56

(C-114)

1	2	3	4	5	6	7	8	9	10	11	12	13	14	15	16	17	18	19	20
---	---	---	---	---	---	---	---	---	----	----	----	----	----	----	----	----	----	----	----

(D-13) MU801441

M	
1	2

TSB Revision

2

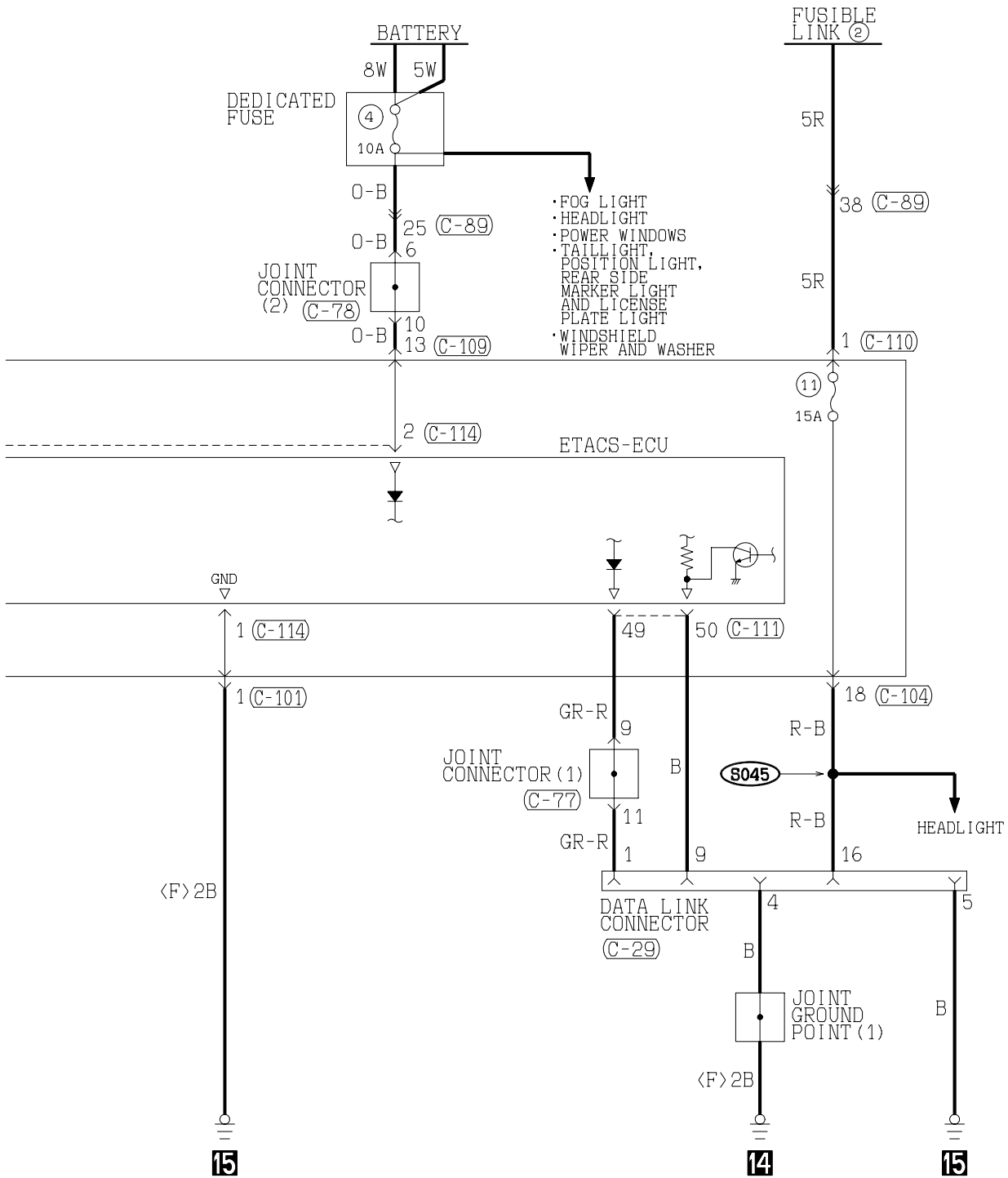

(C-89)

1	2	3	4	5	6	7	8	9	10	11	12	13
14	15	16	17	18	19	20	21	22	23	24	25	38
26	27	28	29					30	31			
32	33	34		35				36	37			

(C-90)

1	2	3	4		5	6	7	8	9		
10	11	12	13	14	15	16	17	18	19	20	21
22	23	24	25	26	27	28	29	30	31	32	33
34	35	36	37		38	39	40	41	42	43	

(C-101)

1	2
3	4
5	6

(C-104)

1	2	3	4	5	6	7	8	9		
10	11	12	13	14	15	16	17	18	19	20

(C-109)

1	2	3	4	5	6	7	8		
9	10	11	12	13	14	15	16	17	18

(C-110)

1
---

TSB Revision

IMMOBILIZER SYSTEM <2.4L ENGINE-M/T>

M1901013600099

1

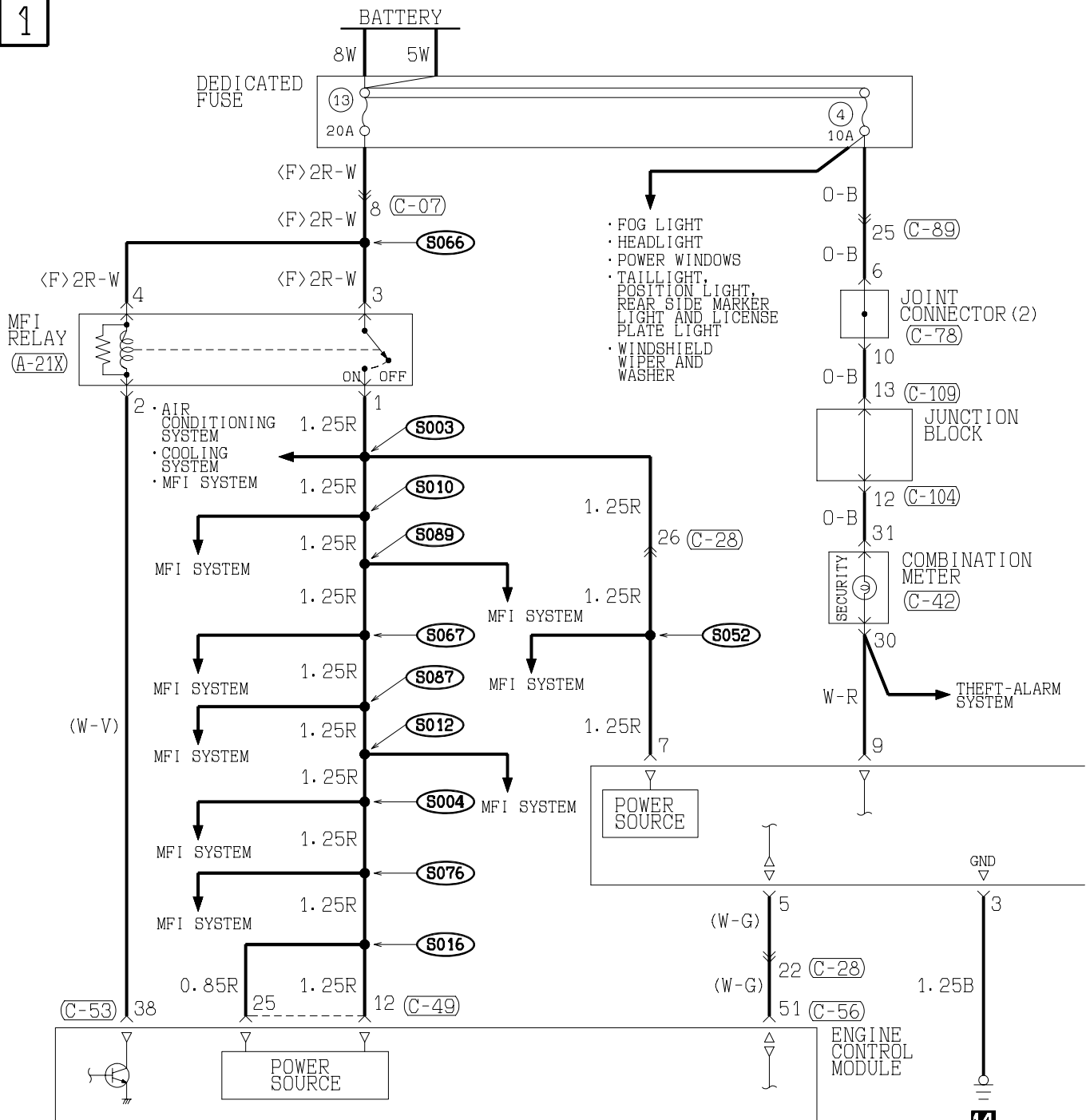

14

(A-21X)

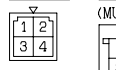

(C-03)



(C-07)

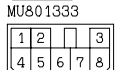

(C-28)

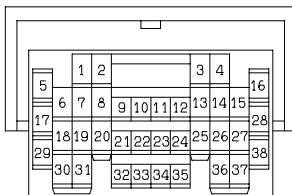

(C-29) FRONT SIDE

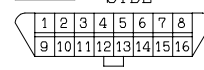

(C-42)

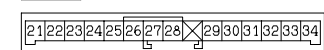

(C-88)

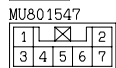

(C-89)

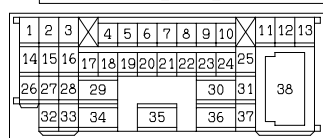

H1S15M52AA

TSB Revision

2

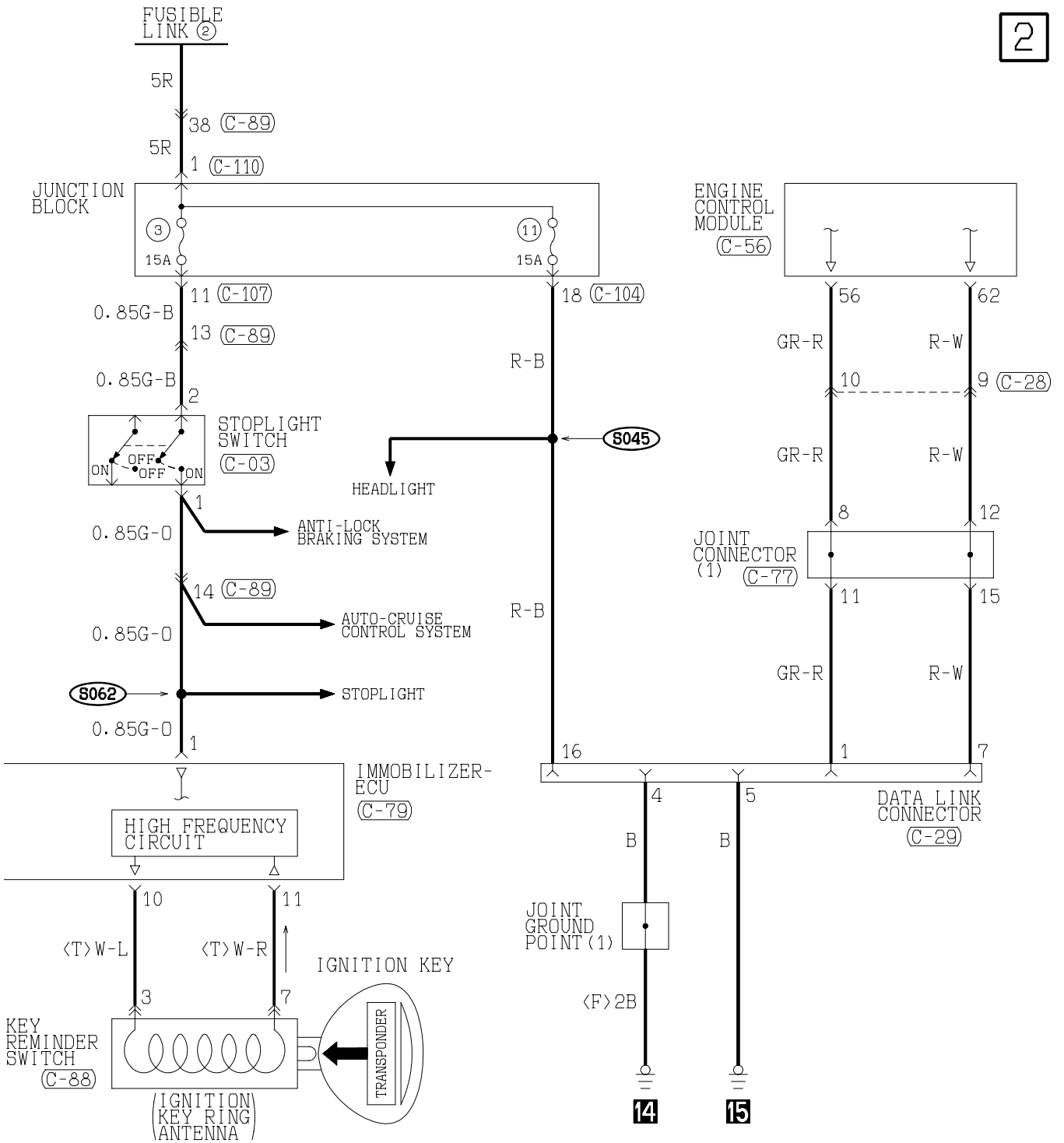

(C-49) (MU803773)

1	2	3	4	5	6	7	8	9	10	11	12	13
14	15	16	17	18	19	20	21	22	23	24	25	26

(C-53) (MU803771)

31	32	33	34	35	36	37	38
39	40	41	42	43	44	45	46

(C-56) (MU803770)

51	52	53	54	55	56
57	58	59	60	61	62

(C-77)

1	2	3	4	5	6	7	8	9	10	11
12	13	14	15	16	17	18	19	20	21	22
23	24	25	26	27	28	29	30	31	32	33

(C-78)

1	2	3	4	5	6	7	8	9	10	11
12	13	14	15	16	17	18	19	20	21	22
23	24	25	26	27	28	29	30	31	32	33

(C-79) (MU801468)

1	2	3	4	5		
6	7	8	9	10	11	12

(C-104) MU801457

1	2	3	4	5	6	7	8	9		
10	11	12	13	14	15	16	17	18	19	20

(C-107)

1	2	3	4	5	6	7	8	9	10		
11	12	13	14	15	16	17	18	19	20	21	22

(C-109)

1	2	3	4	5	6	7	8		
9	10	11	12	13	14	15	16	17	18

(C-110)

1
---

TSB Revision

# IMMOBILIZER SYSTEM <2.4L ENGINE-A/T>

M1901013600107

1

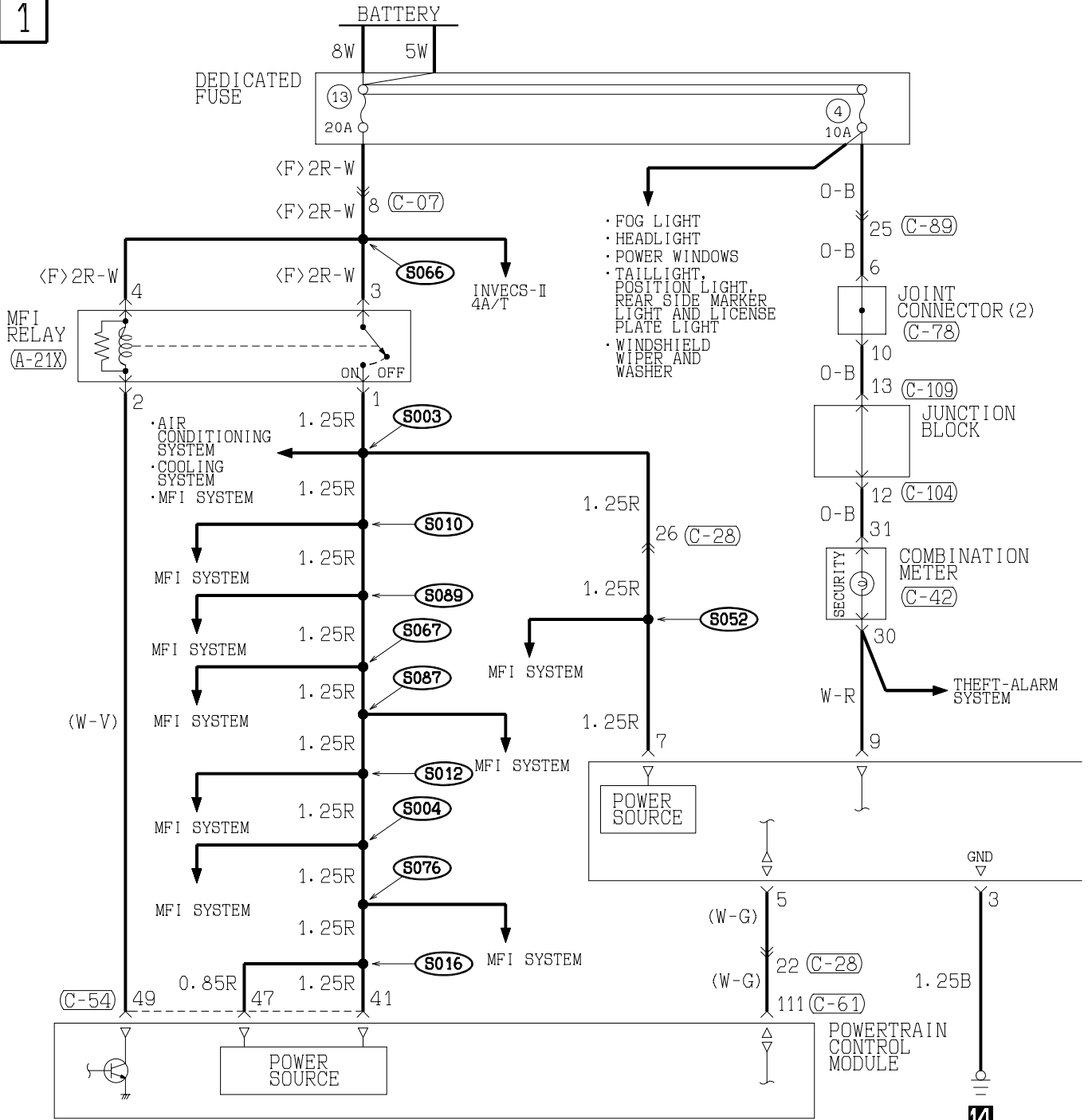

14

(A-21X)

(C-03)

(C-07)

(C-28)

(C-29)

FRONT SIDE

(C-42)



(C-79)

(C-88)

(C-89)



H1S15M53AA

TSB Revision

2

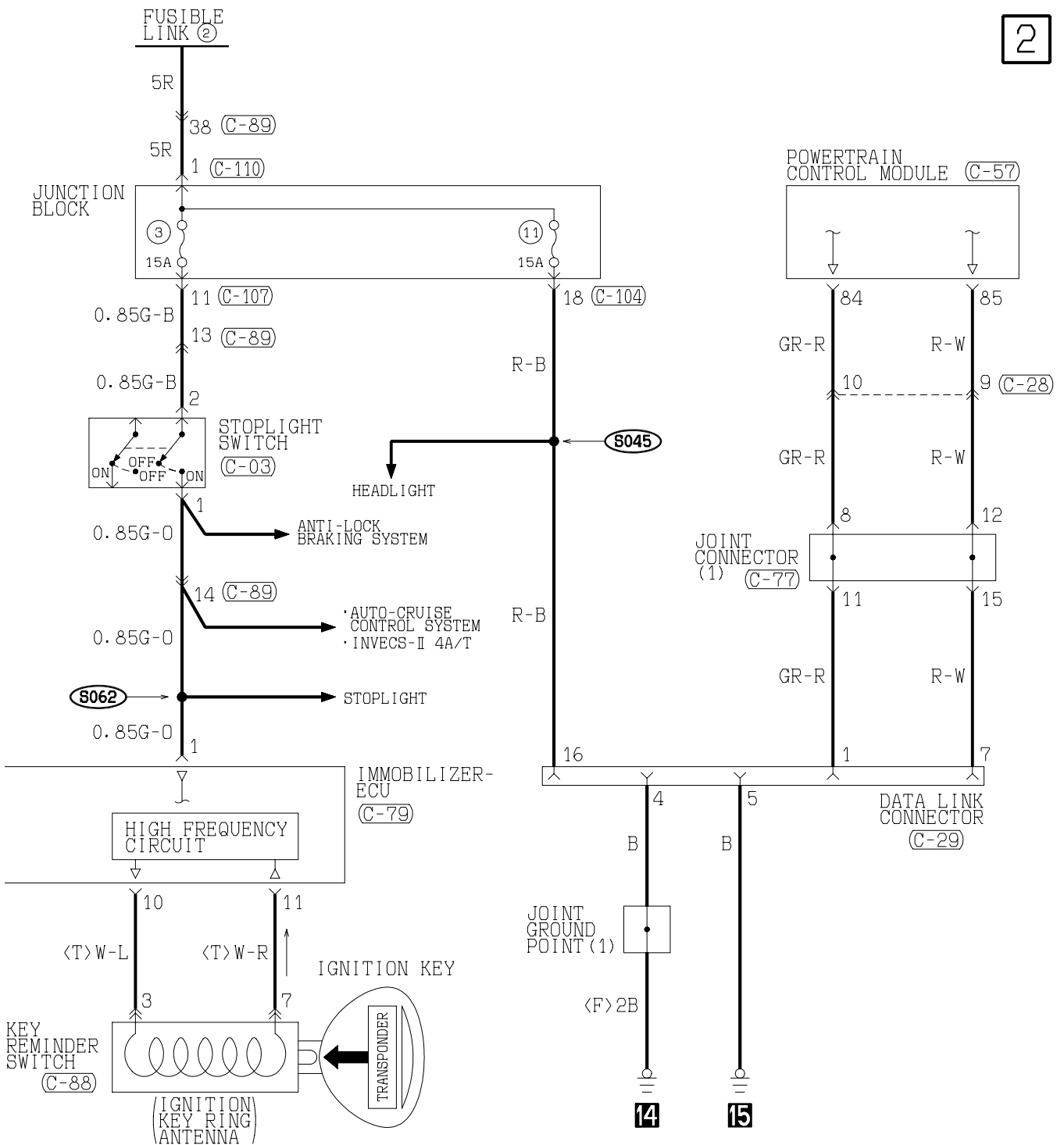

(C-54) (MU803781)

41	42	43		44	45	46
47	48	49	50	51	52	53
54	55	56	57	58	59	60
61	62	63	64	65	66	

(C-57) (MU803782)

71	72	73	74		75	76	77
78	79	80	81	82	83	84	85
86	87	88	89	90	91	92	93
94	95	96	97	98			

(C-61) (MU803783)

101	102	103	104		105	106	107
108	109	110	111	112	113	114	115
116	117	118	119	120	121	122	123
124	125	126	127	128	129	130	

(C-77)

1	2	3	4	5	6	7	8	9	10	11
12	13	14	15	16	17	18	19	20	21	22
23	24	25	26	27	28	29	30	31	32	33

(C-78)

1	2	3	4	5	6	7	8	9	10	11
12	13	14	15	16	17	18	19	20	21	22
23	24	25	26	27	28	29	30	31	32	33

(C-104)

MU801457

1	2	3	4	5	6	7	8	9
10	11	12	13	14	15	16	17	18
19	20							

(C-107)

1	2	3	4	5	6	7	8	9	10
11	12	13	14	15	16	17	18	19	20
21	22								

(C-109)

1	2	3	4	5	6	7	8
9	10	11	12	13	14	15	16
17	18						

(C-110)

1
---

H1S15M53AB

TSB Revision

# IMMOBILIZER SYSTEM <3.0L ENGINE-M/T>

M1901013600118

1

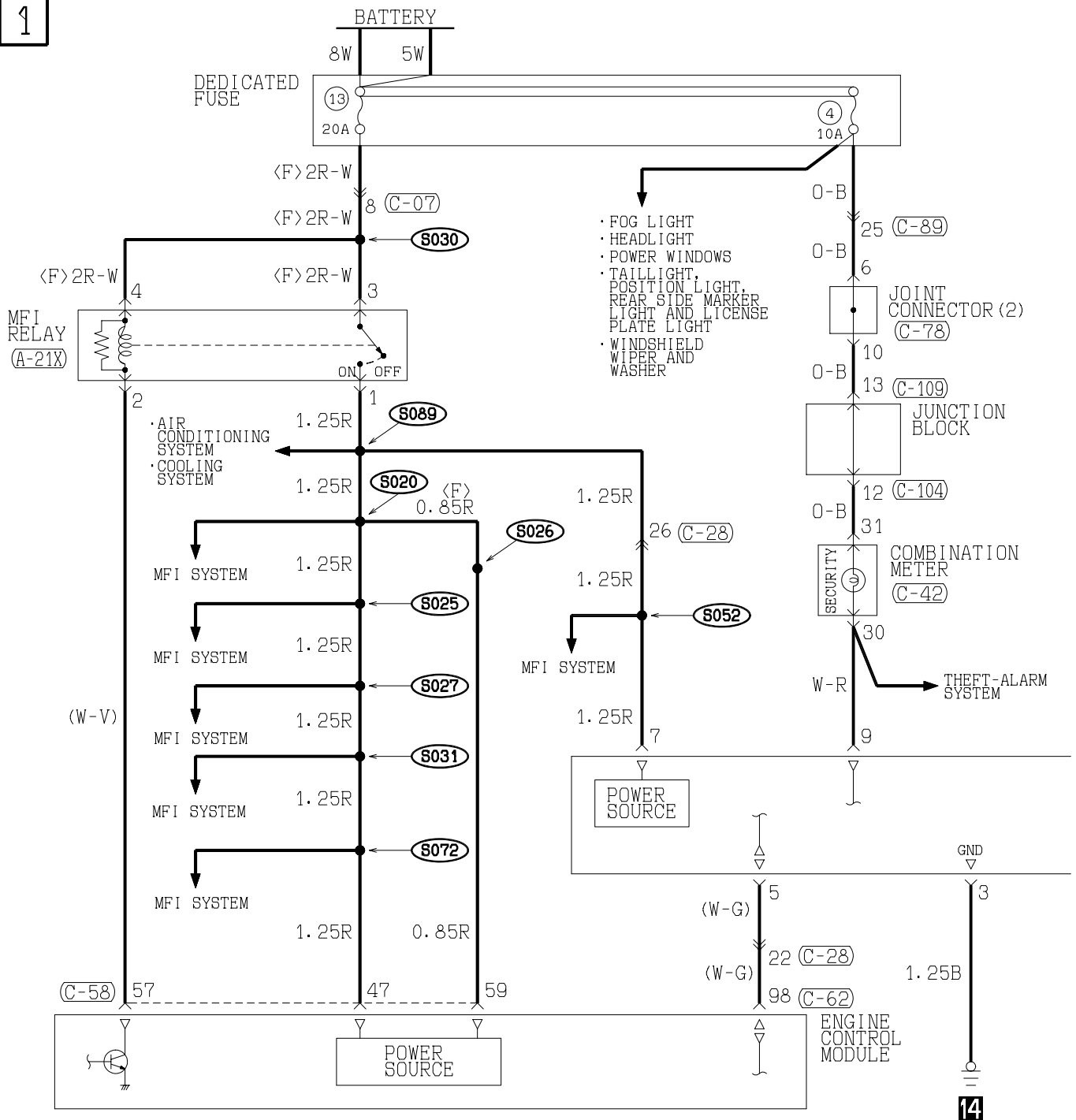

14

(A-21X)



(C-03)

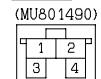

(C-07)

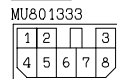

(C-28)

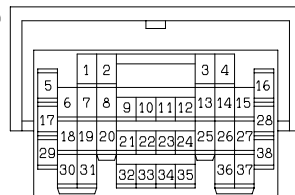

(C-29) FRONT SIDE

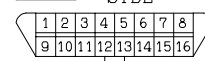

(C-42)

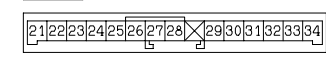

(C-88)

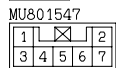

(C-89)

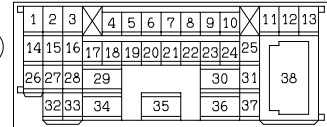

H1S15M54AA

TSB Revision



2

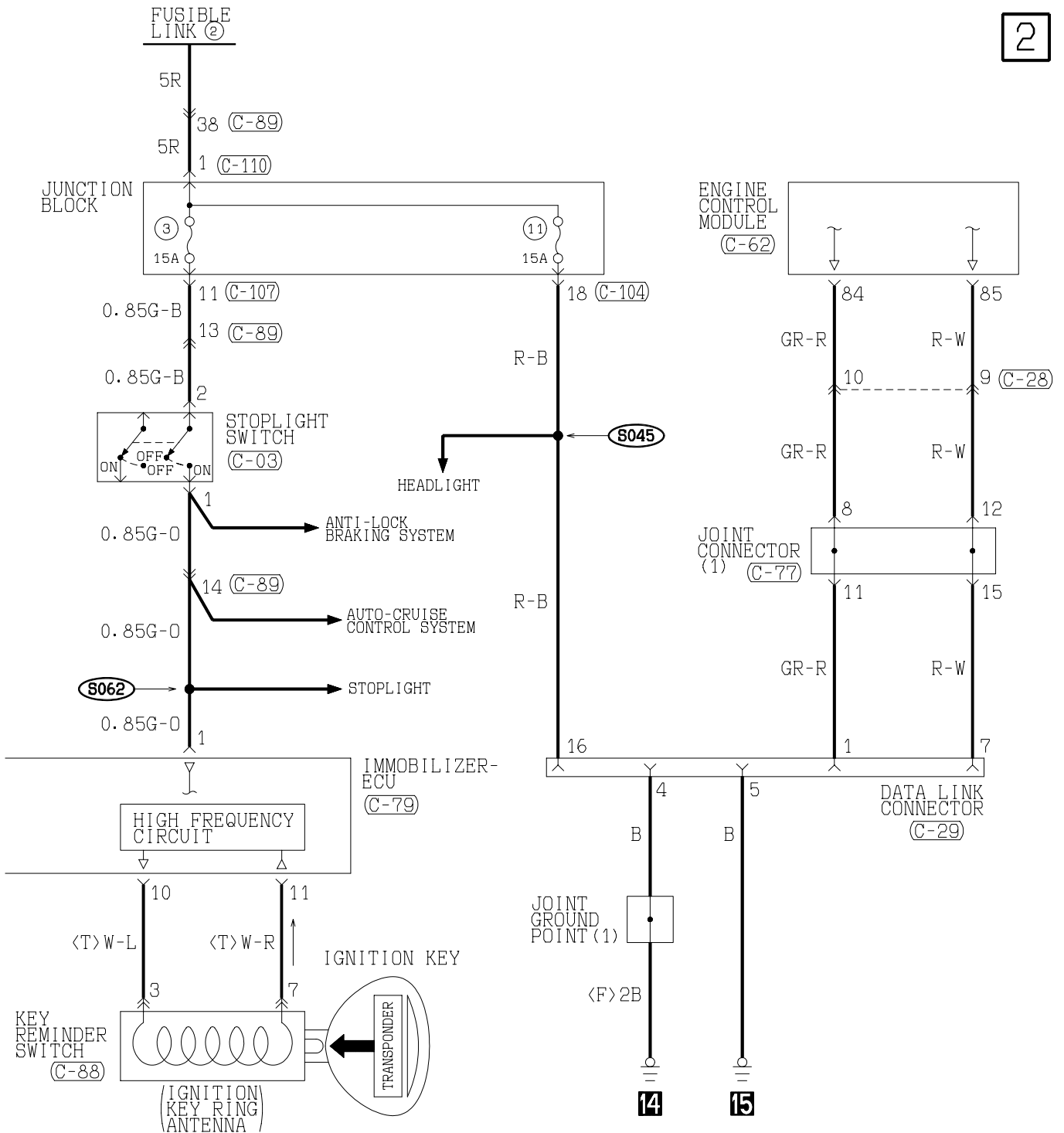

(C-58) (MU803782)

41	42	43	44	45	46	47					
48	49	50	51	52	53	54	55	56	57	58	59
60	61	62	63	64	65	66	67	68			

(C-62) (MU803783)

71	72	73	74	75	76	77						
78	79	80	81	82	83	84	85	86	87	88	89	90
91	92	93	94	95	96	97	98	99	100			

(C-77)

1	2	3	4	5	6	7	8	9	10	11
12	13	14	15	16	17	18	19	20	21	22
23	24	25	26	27	28	29	30	31	32	33

(C-78)

1	2	3	4	5	6	7	8	9	10	11
12	13	14	15	16	17	18	19	20	21	22
23	24	25	26	27	28	29	30	31	32	33

(C-79)

1	2	3	4	5		
6	7	8	9	10	11	12

(C-104)

1	2	3	4	5	6	7	8	9		
10	11	12	13	14	15	16	17	18	19	20

(C-107)

1	2	3	4	5	6	7	8	9	10		
11	12	13	14	15	16	17	18	19	20	21	22

(C-109)

1	2	3	4	5	6	7	8		
9	10	11	12	13	14	15	16	17	18

(C-110)

1
---

TSB Revision

IMMOBILIZER SYSTEM <3.0L ENGINE-A/T>

M1901013600129

1

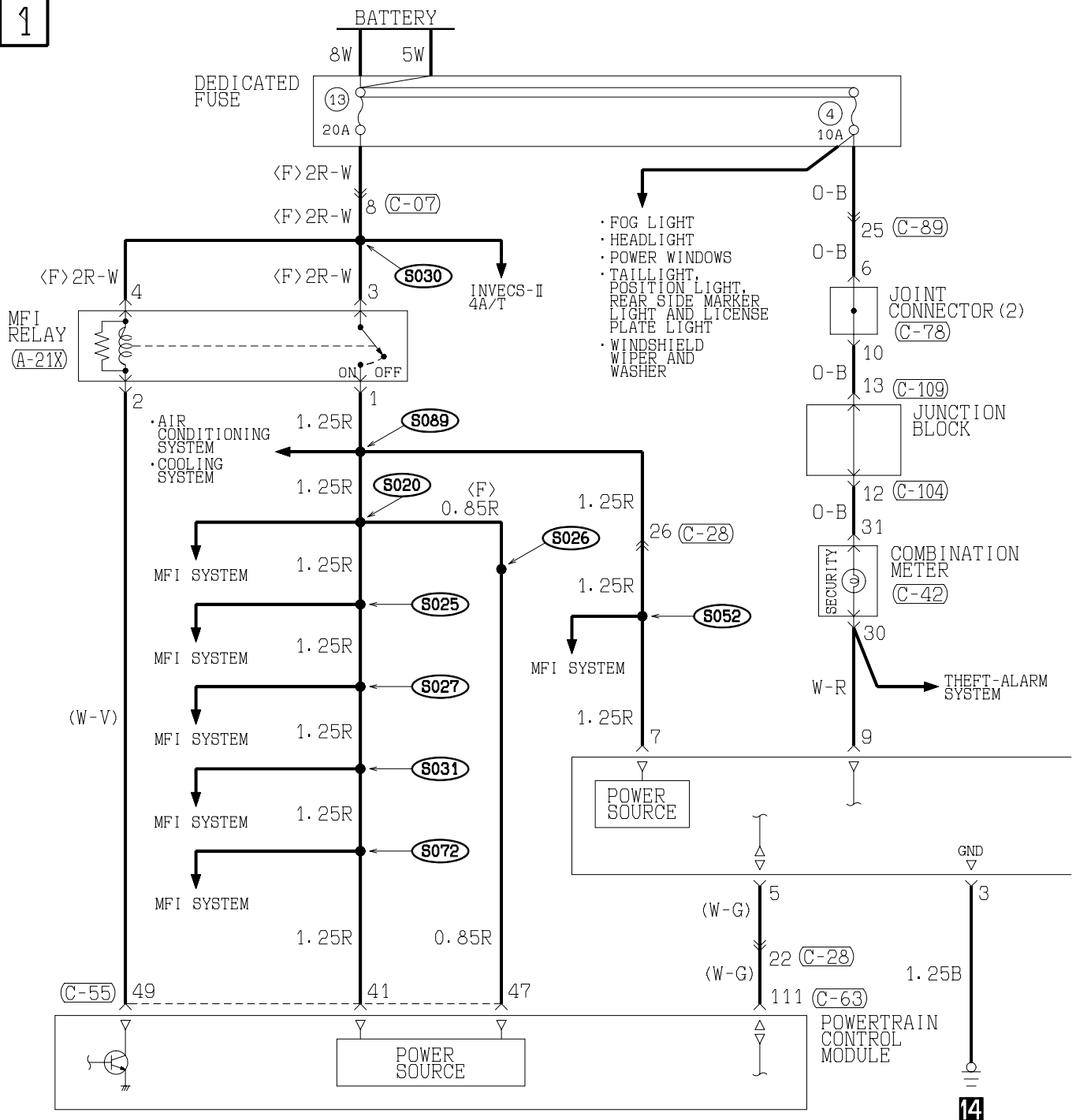

14

(A-21X)



(C-03)

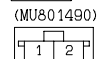

(C-07)



(C-28)



(C-29) FRONT SIDE

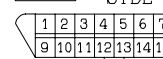

(C-42)



(C-79)



(C-88)



(C-89)



H1S15M55AA

TSB Revision

2

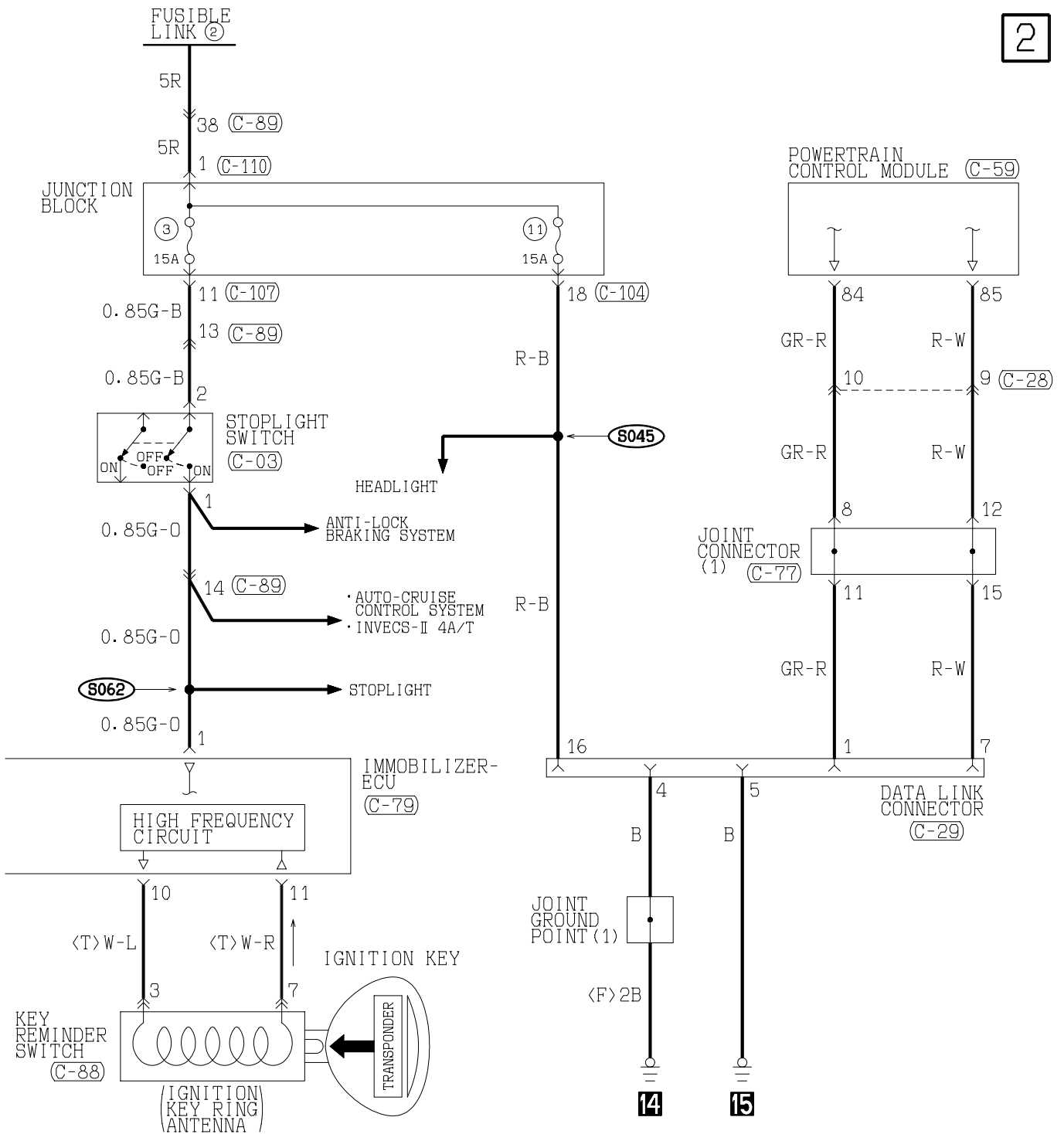

(C-55) (MU803781)

41	42	43		44	45	46
47	48	49	50	51	52	53
54	55	56	57	58	59	60
61	62	63	64	65	66	

(C-59) (MU803782)

71	72	73	74		75	76	77
78	79	80	81	82	83	84	85
86	87	88	89	90	91	92	93
94	95	96	97	98			

(C-63) (MU803783)

101	102	103	104		105	106	107
108	109	110	111	112	113	114	115
116	117	118	119	120	121	122	123
124	125	126	127	128	129	130	

(C-77)

1	2	3	4	5	6	7	8	9	10	11
12	13	14	15	16	17	18	19	20	21	22
23	24	25	26	27	28	29	30	31	32	33

(C-78)

1	2	3	4	5	6	7	8	9	10	11
12	13	14	15	16	17	18	19	20	21	22
23	24	25	26	27	28	29	30	31	32	33

(C-104)

1	2	3	4	5	6	7	8	9
10	11	12	13	14	15	16	17	18
19	20							

(C-107)

1	2	3	4	5	6	7	8	9	10
11	12	13	14	15	16	17	18	19	20
21	22								

(C-109)

1	2	3	4	5	6	7	8
9	10	11	12	13	14	15	16
17	18						

(C-110)

1
---

TSB Revision

# SUNROOF

M1901009900075

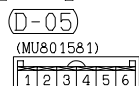
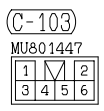
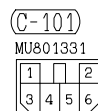
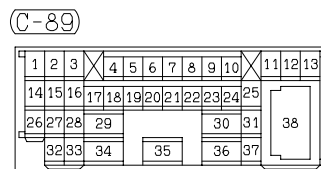
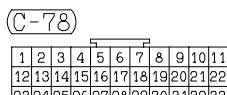
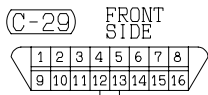
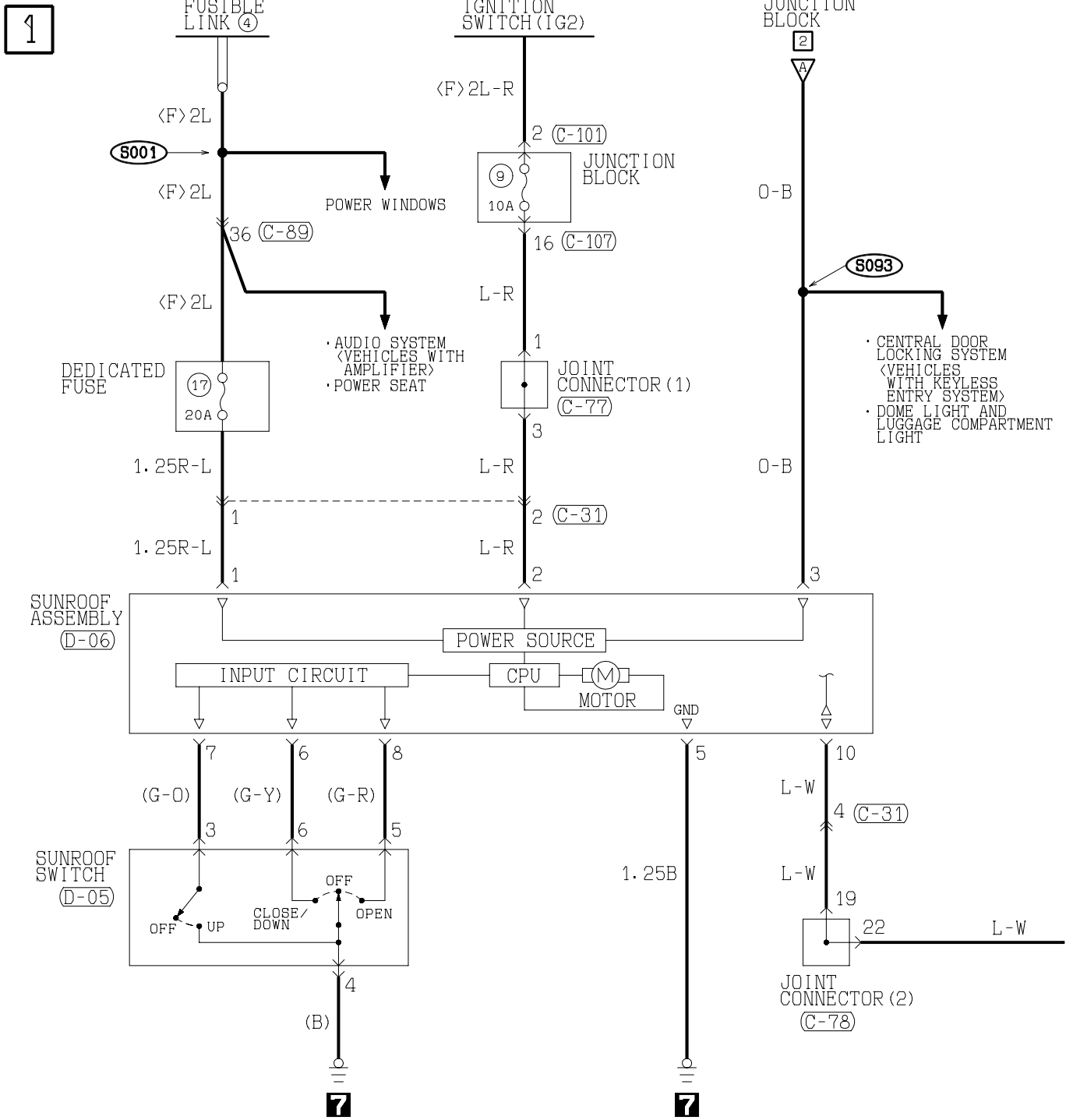

H1S15M44AA

TSB Revision

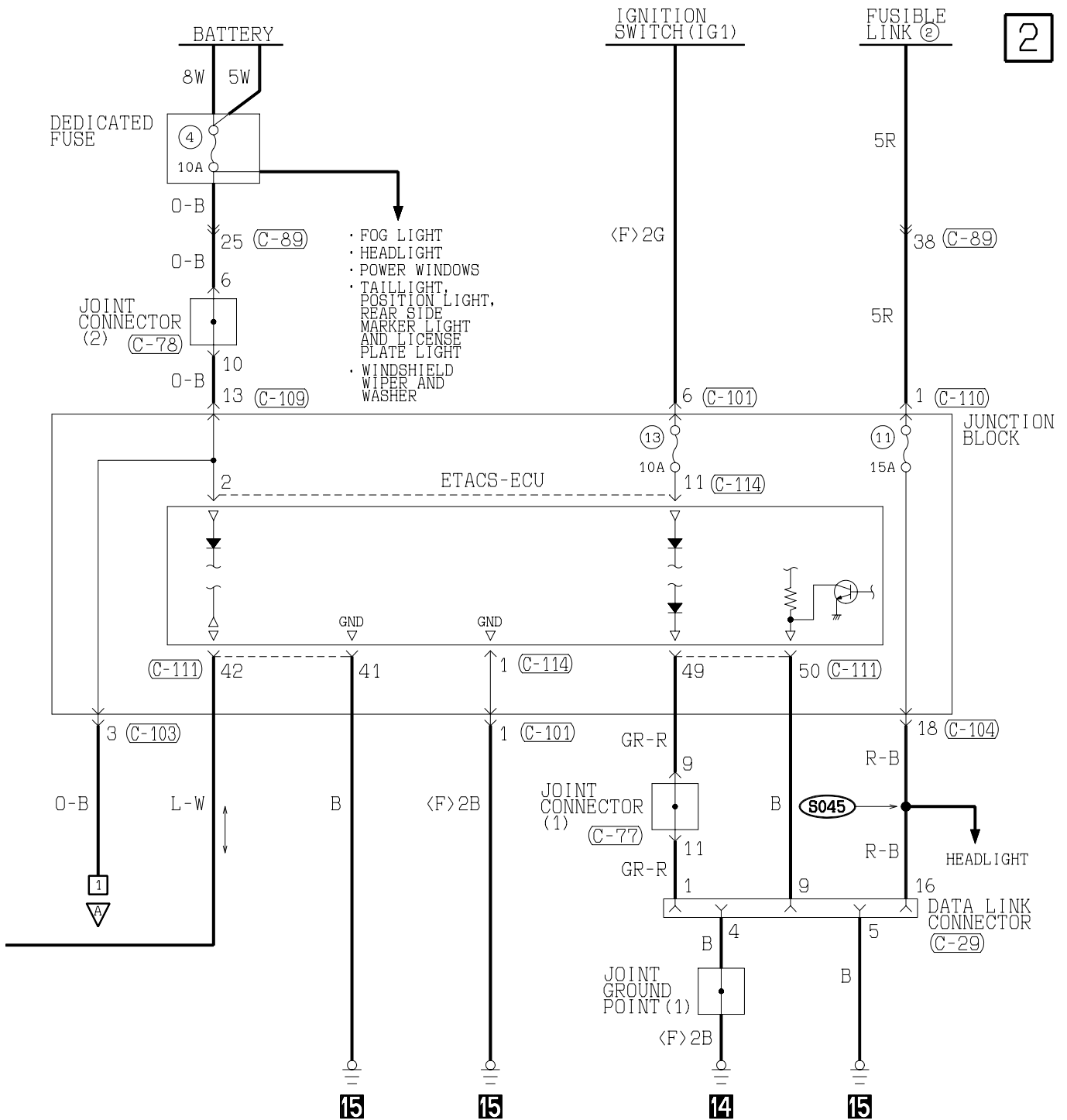

2

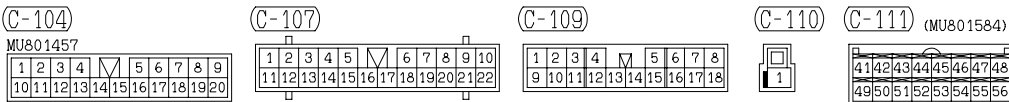

WIRE COLOR CODE  
B : BLACK BR : BROWN G : GREEN GR : GRAY L : BLUE LG : LIGHT GREEN O : ORANGE  
P : PINK R : RED SB : SKY BLUE V : VIOLET W : WHITE Y : YELLOW

TSB Revision

---

## NOTES

# RHEOSTAT

M1901011100076

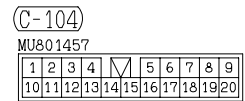
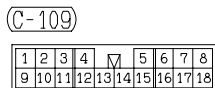
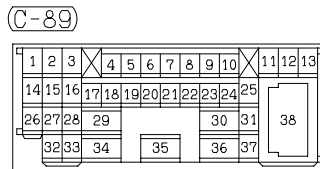
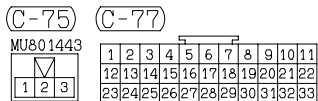
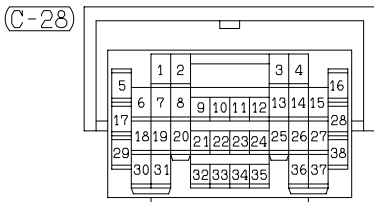
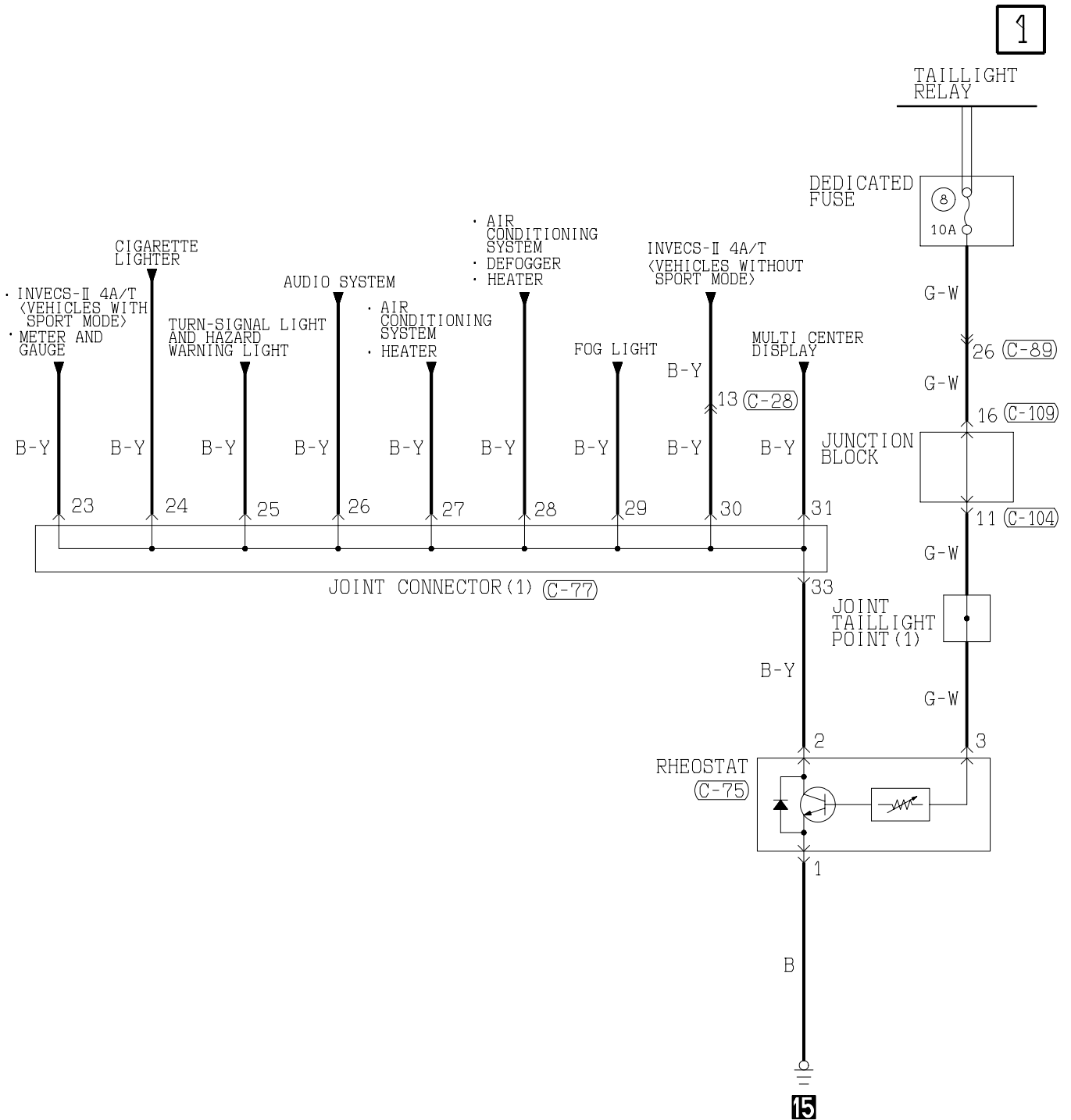

H1S15M51AA

TSB Revision

# CONVERTIBLE TOP

1

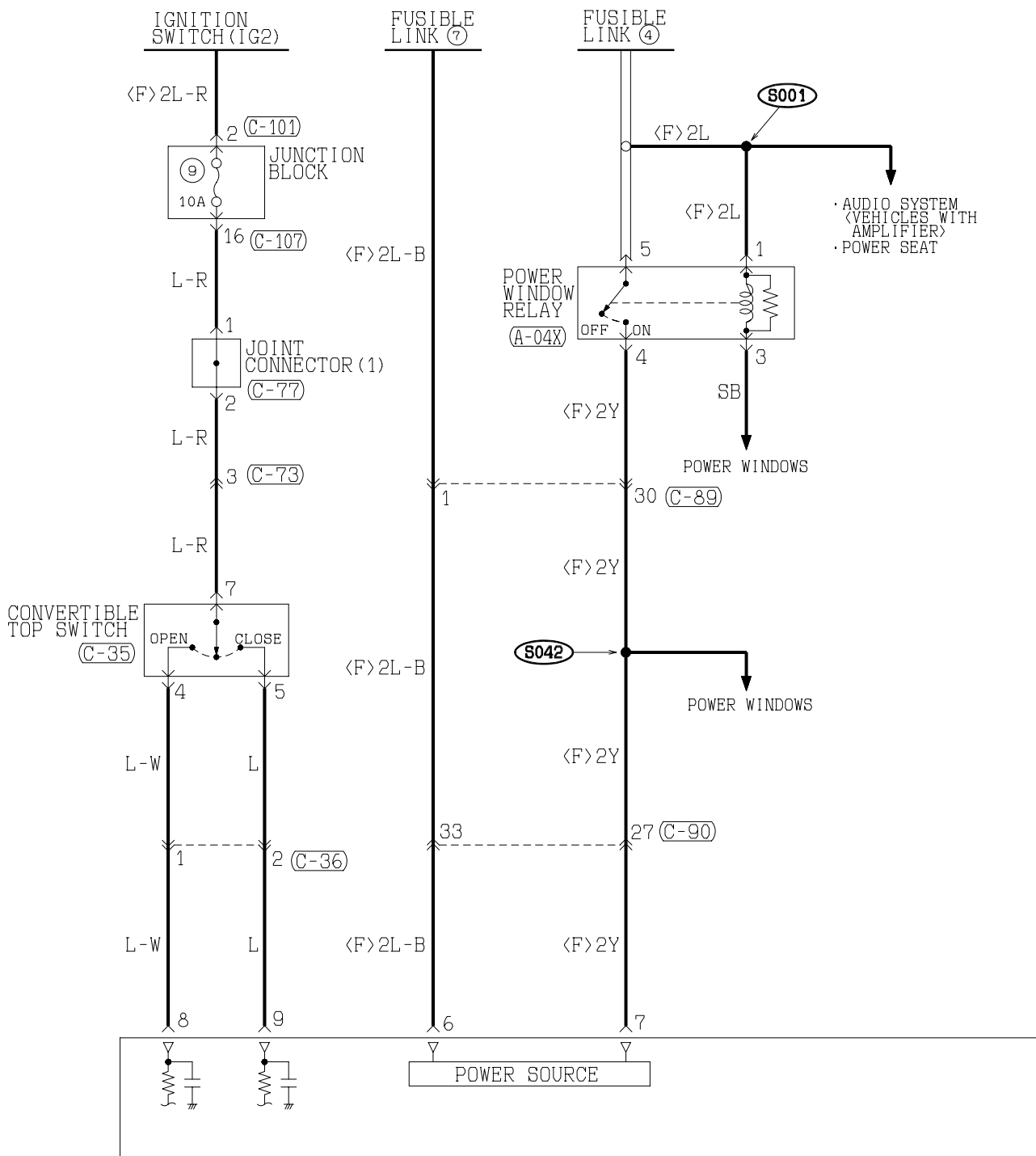

(A-04X)



(C-35)



(C-36)



(C-73)



(C-77)



(C-89)

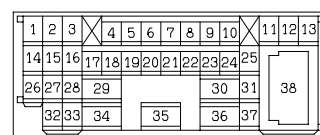

(C-90)

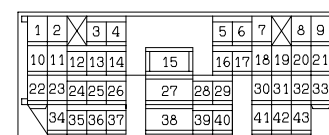

TSB Revision



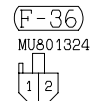
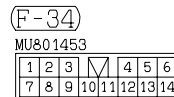
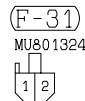
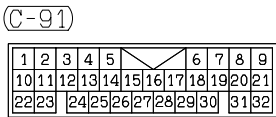
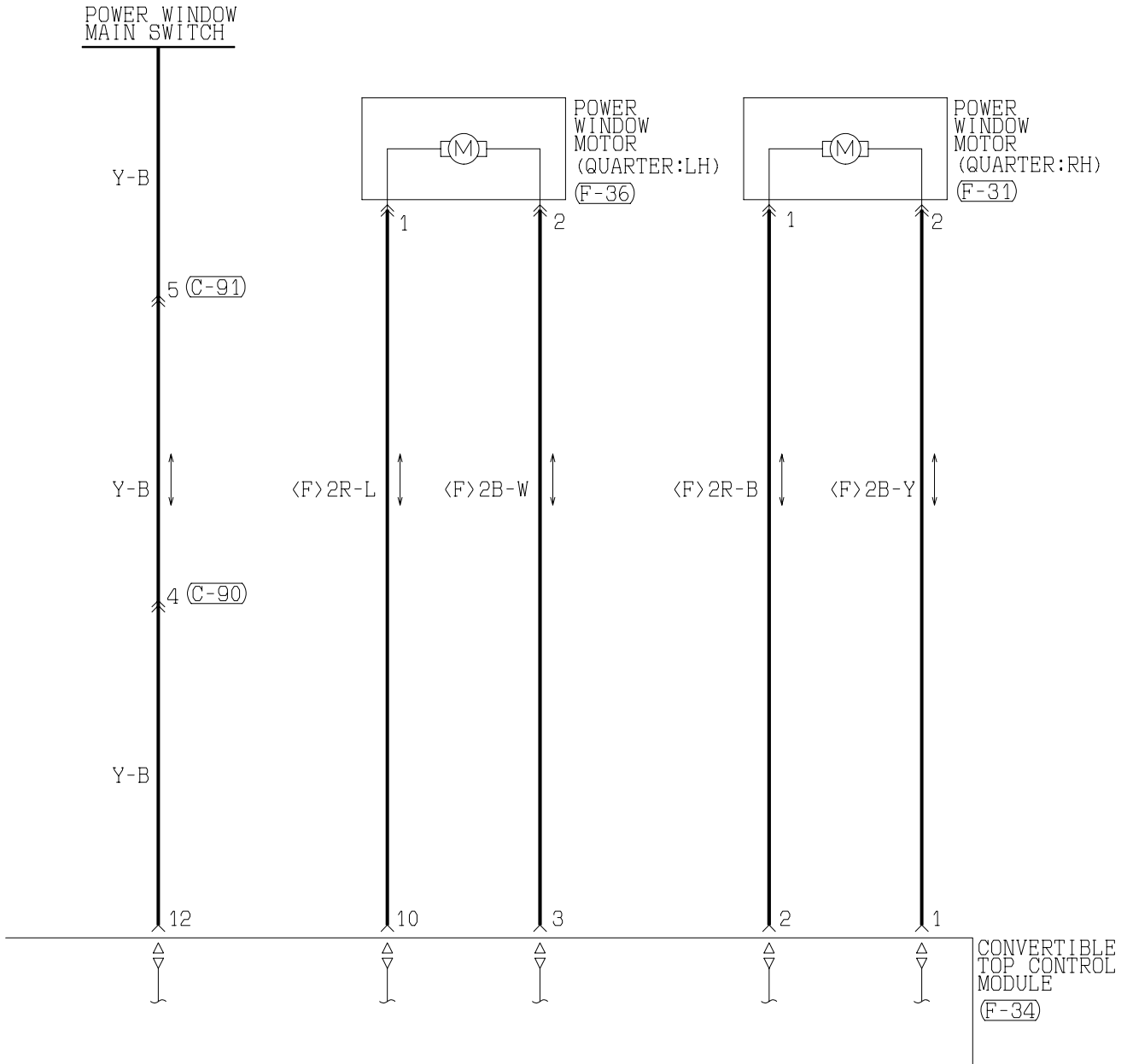

WIRE COLOR CODE  
 B : BLACK BR : BROWN G : GREEN GR : GRAY L : BLUE LG : LIGHT GREEN O : ORANGE  
 P : PINK R : RED SB : SKY BLUE V : VIOLET W : WHITE Y : YELLOW

H1S15M45AB

TSB Revision

CONVERTIBLE TOP (CONTINUED)

3

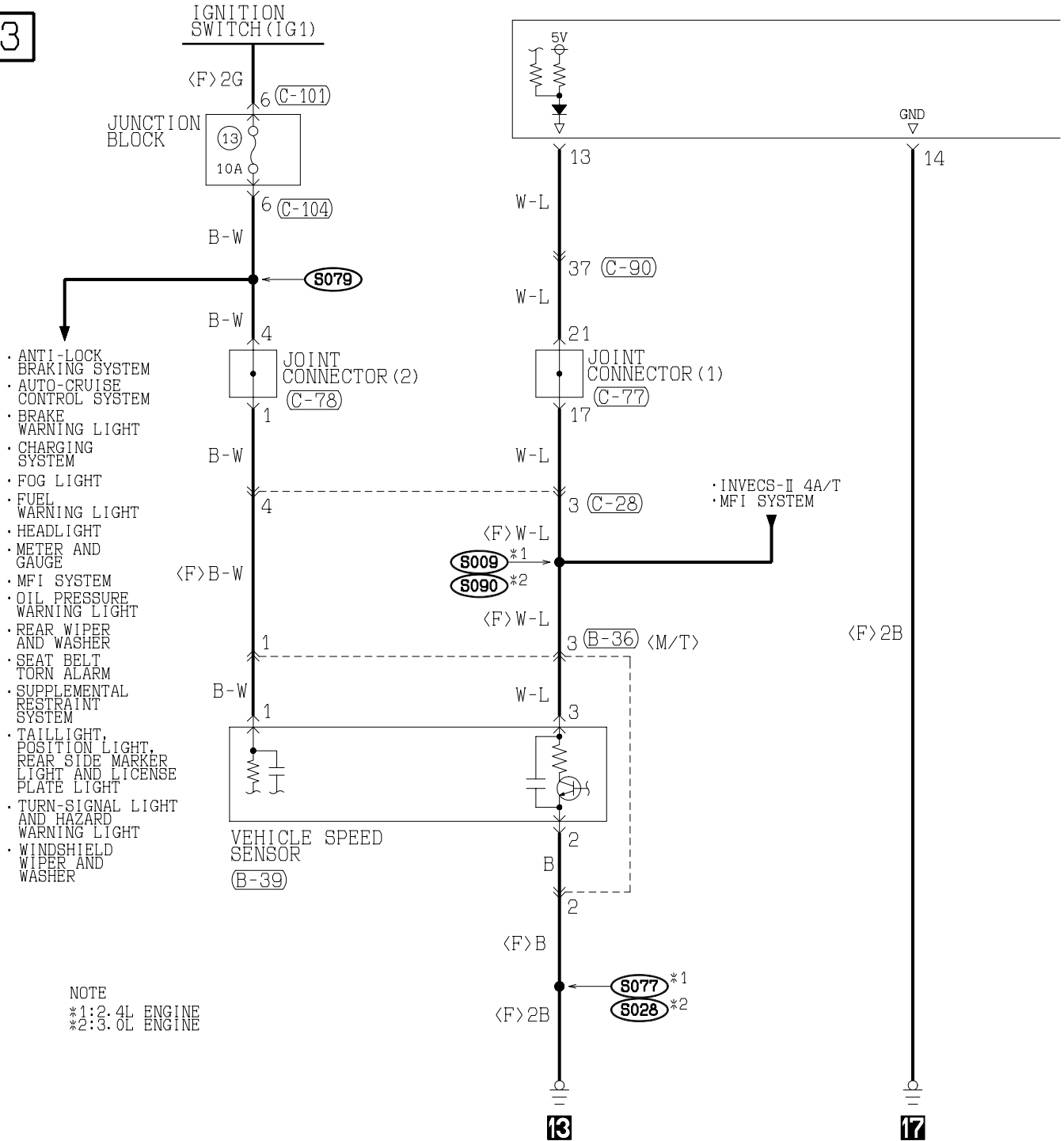

- ANTI-LOCK BRAKING SYSTEM
- AUTO-CRUISE CONTROL SYSTEM
- BRAKE WARNING LIGHT
- CHARGING SYSTEM
- FOG LIGHT
- FUEL WARNING LIGHT
- HEADLIGHT
- METER AND GAUGE
- MFI SYSTEM
- OIL PRESSURE WARNING LIGHT
- REAR WIPER AND WASHER
- SEAT BELT TORN ALARM
- SUPPLEMENTAL RESTRAINT SYSTEM
- TAILLIGHT, POSITION LIGHT, REAR SIDE MARKER LIGHT AND LICENSE PLATE LIGHT
- TURN-SIGNAL LIGHT AND HAZARD WARNING LIGHT
- WINDSHIELD WIPER AND WASHER

NOTE  
\*1: 2.4L ENGINE  
\*2: 3.0L ENGINE

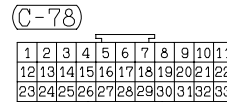
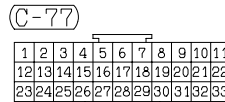
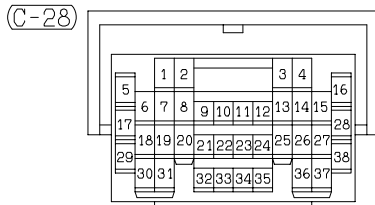

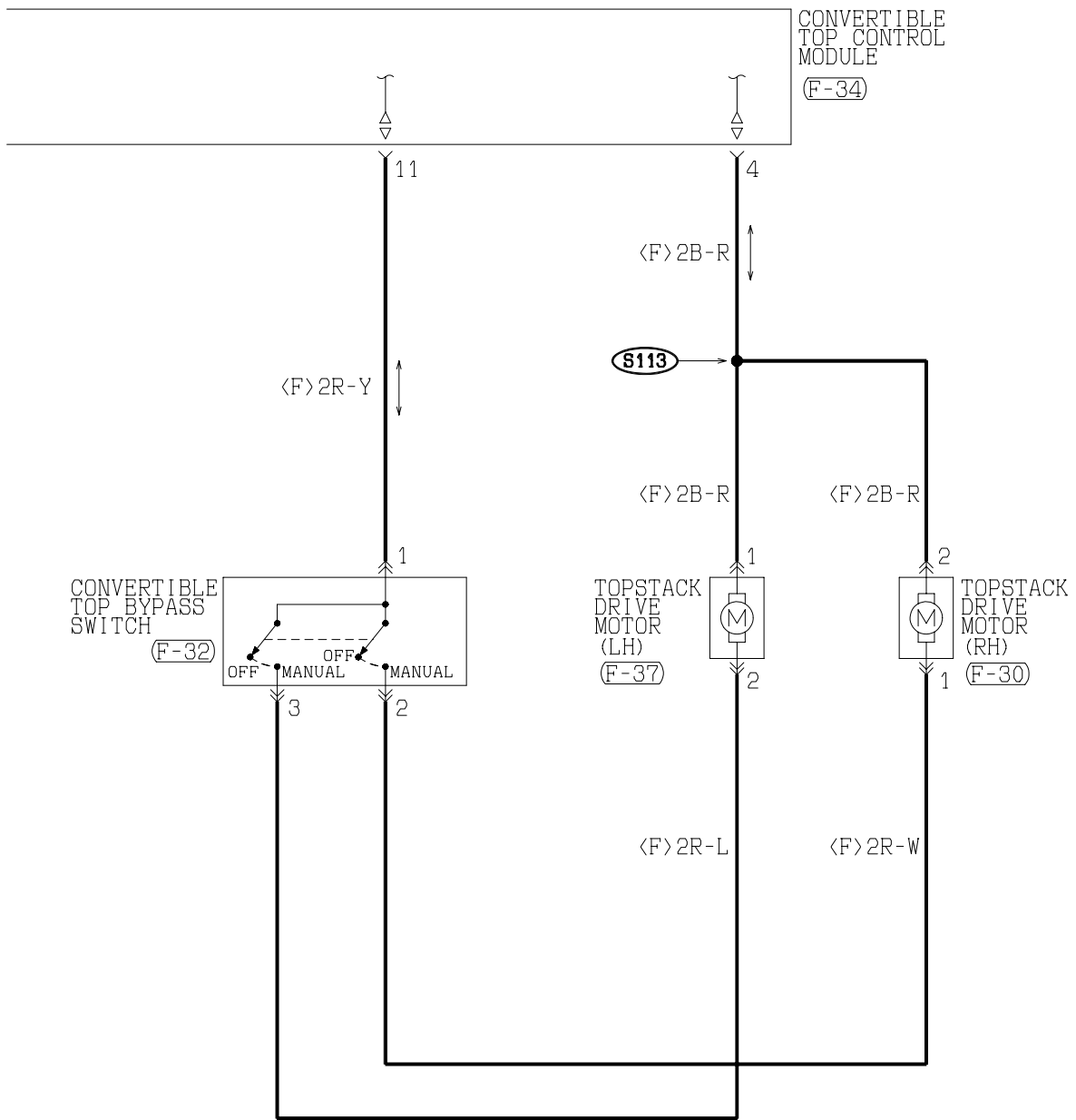

(C-90)

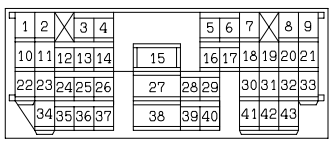

(C-101)

MU801331



(C-104)

MU801457

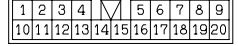

(F-30)

MU801441



(F-32)

MU801441



(F-34)

MU801453

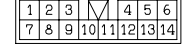

(F-37)

MU801441



WIRE COLOR CODE

- B : BLACK
- L : BLUE
- R : RED
- Y : YELLOW
- BR : BROWN
- LG : LIGHT GREEN
- SB : SKY BLUE
- G : GREEN
- O : ORANGE
- V : VIOLET
- GR : GRAY
- P : PINK
- W : WHITE

H1S15M45BB

TSB Revision

# UNIVERSAL GARAGE DOOR OPENER

M1901014000034

1

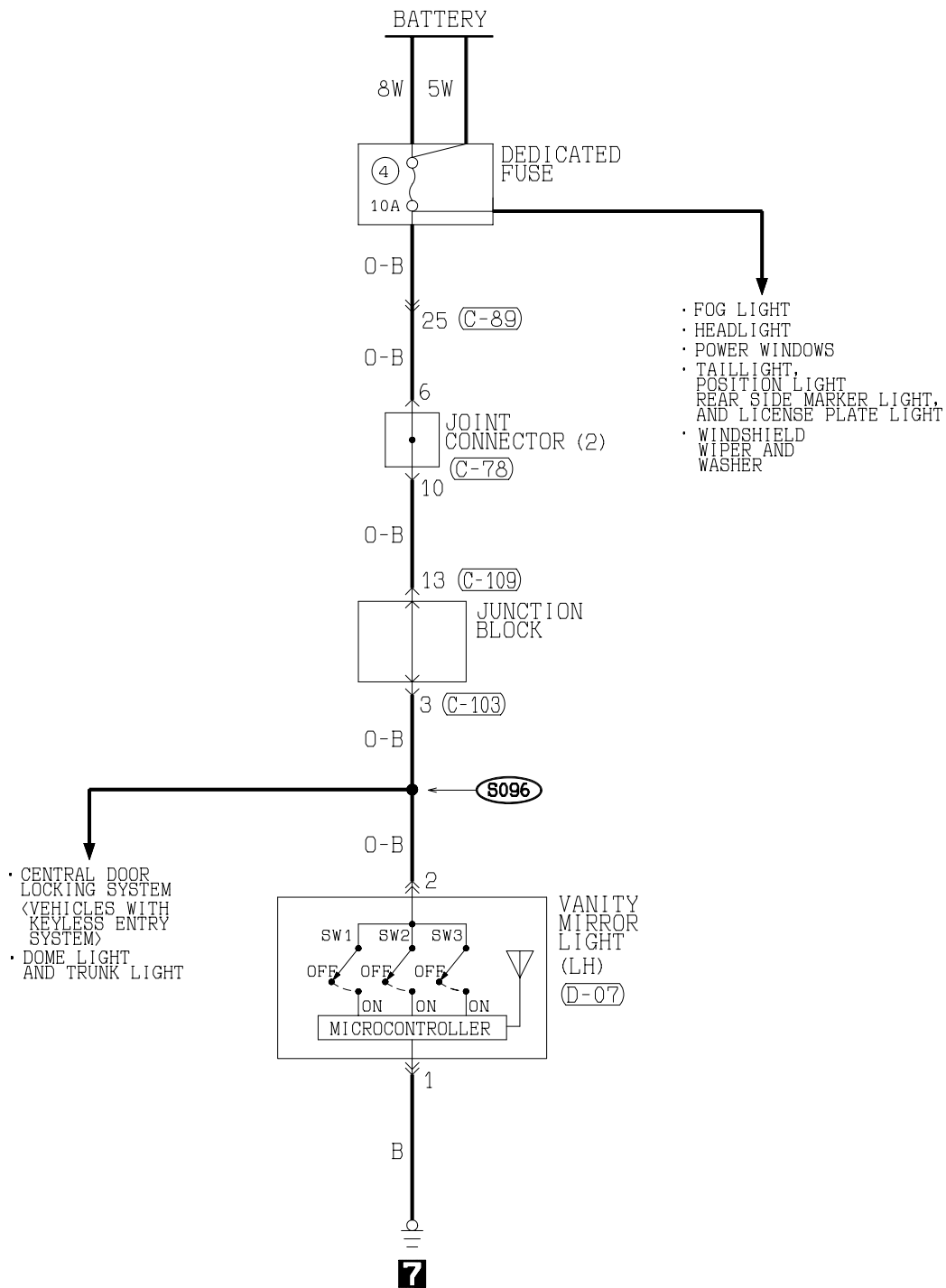

- FOG LIGHT
- HEADLIGHT
- POWER WINDOWS
- TAILLIGHT
- POSITION LIGHT
- REAR SIDE MARKER LIGHT, AND LICENSE PLATE LIGHT
- WINDSHIELD WIPER AND WASHER
- CENTRAL DOOR LOCKING SYSTEM (VEHICLES WITH KEYLESS ENTRY SYSTEM)
- DOME LIGHT AND TRUNK LIGHT

(C-78)

1	2	3	4	5	6	7	8	9	10	11
12	13	14	15	16	17	18	19	20	21	22
23	24	25	26	27	28	29	30	31	32	33

(C-89)

1	2	3	4	5	6	7	8	9	10	11	12	13		
14	15	16	17	18	19	20	21	22	23	24	25			
26	27	28	29			30	31		32	33	34	35		
												36	37	38

(C-103)

1	2
3	4

(C-109)

1	2	3	4	5	6	7	8
9	10	11	12	13	14	15	16
17	18						

(D-07)

1	2
---	---

WIRE COLOR CODE  
 B : BLACK BR : BROWN G : GREEN GR : GRAY  
 L : BLUE LG : LIGHT GREEN O : ORANGE P : PINK  
 R : RED SB : SKY BLUE V : VIOLET W : WHITE  
 Y : YELLOW

H1S15M56AA

TSB Revision