

## GROUP 52B

# SUPPLEMENTAL RESTRAINT SYSTEM (SRS)

## CONTENTS

<b>GENERAL DESCRIPTION</b> .....	<b>52B-3</b>	<b>INDIVIDUAL COMPONENT SERVICE</b> .....	<b>52B-66</b>
<b>SERVICE PRECAUTIONS</b> .....	<b>52B-15</b>	<b>SRS CONTROL UNIT (SRS-ECU)</b> ...	<b>52B-66</b>
<b>SRS AIR BAG DIAGNOSIS</b> .....	<b>52B-17</b>	REMOVAL AND INSTALLATION .....	52B-66
INTRODUCTION.....	52B-17	INSPECTION.....	52B-68
TROUBLESHOOTING STRATEGY .....	52B-17	<b>AIR BAG MODULE(S) AND CLOCK SPRING</b> .....	<b>52B-69</b>
TROUBLE CODE DIAGNOSIS.....	52B-17	REMOVAL AND INSTALLATION .....	52B-69
DIAGNOSTIC TROUBLE CODE CHART..	52B-18	INSPECTION.....	52B-74
TROUBLE SYMPTOM CHART.....	52B-20	<b>SIDE IMPACT SENSOR</b> .....	<b>52B-76</b>
DIAGNOSTIC TROUBLE CODE PROCEDURES.....	52B-20	REMOVAL AND INSTALLATION .....	52B-76
SRS WARNING LIGHT CHECK.....	52B-56	INSPECTION.....	52B-79
SYMPTOM PROCEDURES .....	52B-57	<b>AIR BAG MODULE AND SEAT BELT PRE-TENSIONER DISPOSAL PROCEDURES</b> .....	<b>52B-80</b>
<b>SPECIAL TOOLS</b> .....	<b>52B-61</b>	<b>SPECIFICATIONS</b> .....	<b>52B-90</b>
<b>TEST EQUIPMENT</b> .....	<b>52B-62</b>	FASTENER TIGHTENING SPECIFICATIONS.....	52B-90
<b>SRS MAINTENANCE</b> .....	<b>52B-62</b>	SERVICE SPECIFICATIONS .....	52B-90
<b>POST-COLLISION DIAGNOSIS</b> ....	<b>52B-62</b>		

**⚠ WARNING**

*Battery posts, terminals and related accessories contain lead and lead compounds. WASH HANDS AFTER HANDLING.*

**⚠ WARNING**

- *Carefully read and observe the information in the SRS SERVICE PRECAUTIONS prior to any service.*
- *For information concerning diagnosis or maintenance, always observe the procedures in the SRS Diagnosis or the SRS Maintenance sections, respectively.*
- *If any SRS components are removed or replaced in connection with any service procedures, be sure to follow the procedures in the INDIVIDUAL COMPONENT SERVICE section for the compartments involved.*
- *If you have any questions about the SRS, please contact the MMSA Tech Line.*

## GENERAL DESCRIPTION

M1524000100075

### **WARNING**

**Extreme care must be used when servicing the SRS to avoid injury to the service personnel (by inadvertent deployment of the air bags) or the driver (by rendering the SRS inoperative).**

The Supplemental Restraint System (SRS) is designed to supplement the driver's and front passenger's seat belts to help reduce the risk or severity of injury to the driver and front passenger by activating and deploying both front air bags in certain frontal collisions.

The SRS consist of two air bag modules, SRS air bag control unit (SRS-ECU), SRS warning light, and clock spring. Air bags are located in the center of the steering wheel and above the glove box. Each air bag is made up of a folded air bag and an inflator unit. The control unit under the floor console monitors the system and has a safing G-sensor and an analog G-sensor. The warning light on the instrument panel indicates the operational status of the SRS. The clock spring is installed in the steering column. Only authorized service personnel should do work on or around the SRS components. Those service personnel should read this manual carefully before starting any such work.

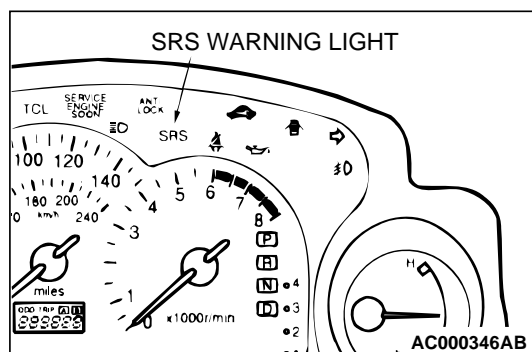

### **ON-BOARD DIAGNOSTIC/SRS WARNING LIGHT FUNCTION**

The diagnosis unit monitors the SRS system and stores data concerning any detected faults in the system. When the ignition switch is in "ON" or "START" position, the SRS warning light should illuminate for about 7 seconds and then turn "OFF". That indicates that the SRS system is in operational order. If the SRS warning light does any of the following, immediate inspection by an authorized dealer is needed.

1. The SRS warning light does not illuminate as described above.
2. The SRS warning light stays on for more than 7 seconds.
3. The SRS warning light illuminates while driving.

CONSTRUCTION DIAGRAM

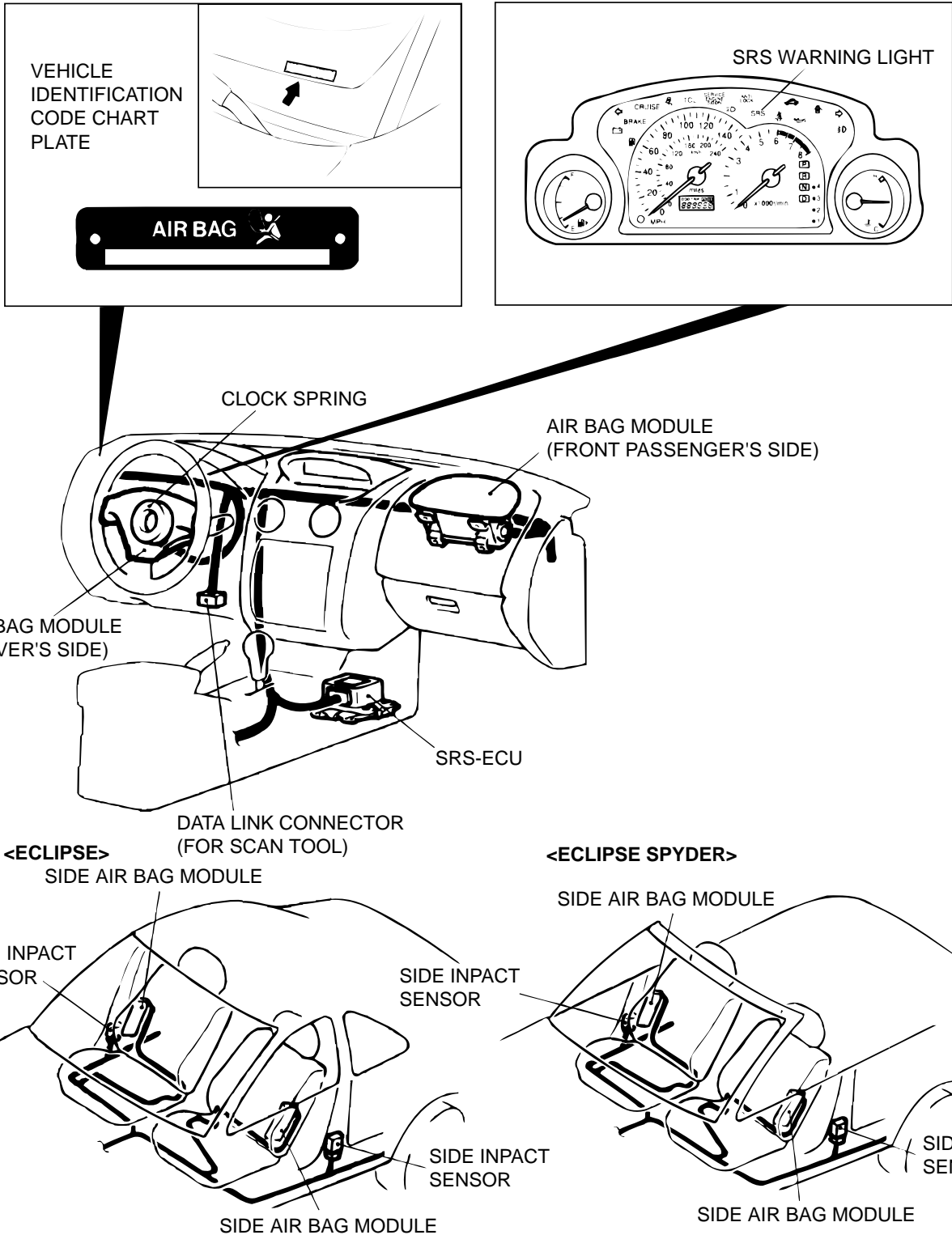

NOTE: This construction diagram shows the general view of the SRS components. For details, refer to "Schematic, (P.52B-8)" "Configuration Diagrams (P.52B-9)" and "Circuit Diagram. (P.52B-10)"

**WARNING/CAUTION LABELS**

A number of caution labels related to the SRS are found in the vehicle, as shown in the following illustration. Follow label instructions when servicing SRS. If labels are dirty or damaged, replace them.

**STEERING WHEEL**

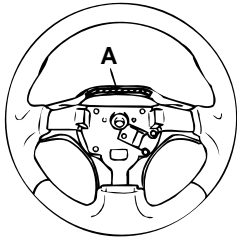

**AIR BAG MODULE  
(DRIVER'S SIDE)**

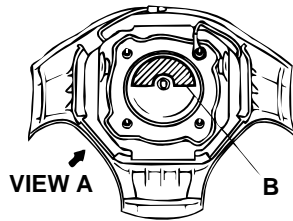

**VIEW A**

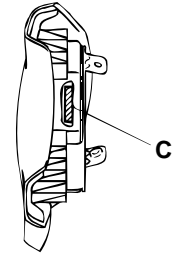

**CLOCK SPRING**

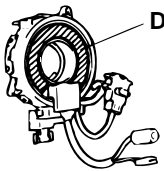

**AIR BAG MODULE  
(FRONT PASSENGER'S SIDE)**

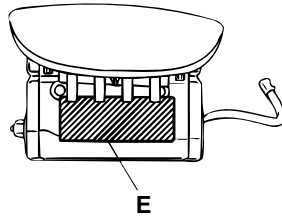

**SRS-ECU**

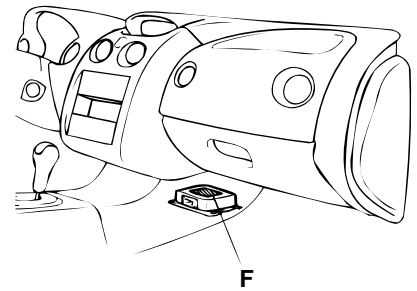

**SUN VISOR<ECLIPS>**

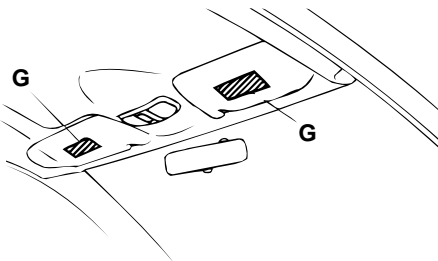

**SUN VISOR<ECLIPS SPYDER>**

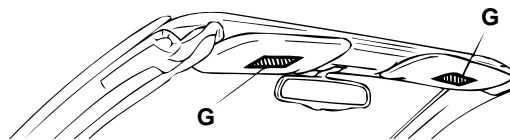

**GROVE BOX**

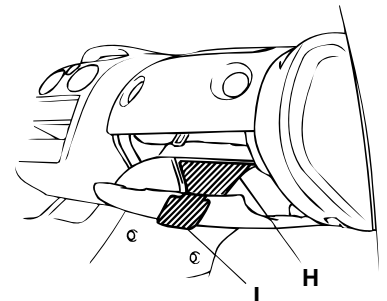

**JOINT COVER**

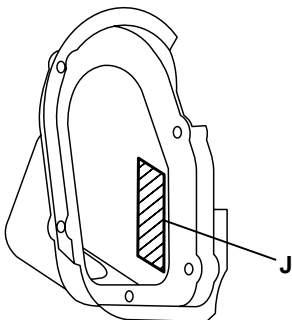

**SIDE AIR BAG MODULE  
(DRIVER'S AND FRONT  
PASSENGER'S SEAT)**

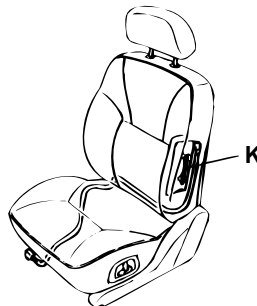

**SIDE IMPACT SENSOR**

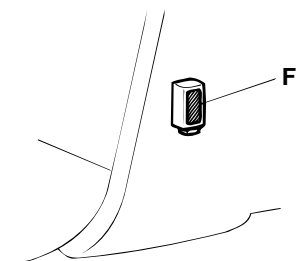

AC003062AB

LABEL CONTENTS	
A.	<p>CAUTION: SRS BEFORE REPLACING STEERING WHEEL, READ SERVICE MANUAL, CENTER FRONT WHEELS AND ALIGN SRS CLOCK SPRING NEUTRAL MARKS. FAILURE TO DO SO MAY RENDER SRS SYSTEM INOPERATIVE, RISKING SERIOUS DRIVER INJURY.</p>
B.	<p>DANGER FLAMMABLE MATERIAL TO PREVENT PERSONAL INJURY, DO NOT DISMANTLE, INCINERATE, OR BRING INTO CONTACT WITH ELECTRICITY STORE BELOW 200 °F (93 °C).</p>
C.	<p>WARNING: SRS THIS AIR BAG MODULE CANNOT BE REPAIRED. DO NOT DISASSEMBLE OR TAMPER. DO NOT PERFORM DIAGNOSIS. DO NOT TOUCH WITH ELECTRICAL TEST EQUIPMENT OR PROBES. REFER TO SERVICE MANUAL FOR FURTHER INSTRUCTIONS, AND FOR SPECIAL HANDLING, STORAGE AND DISPOSAL PROCEDURES, TAMPERING OR MISHANDLING CAN RESULT IN INJURY.</p>
D.	<p>CAUTION: SRS CLOCK SPRING THIS IS NOT A REPAIRABLE PART. IF DEFECTIVE REPLACE ENTIRE UNIT ACCORDING TO THE SERVICE MANUAL INSTRUCTIONS. TO RE-CENTER: ROTATE CLOCKWISE UNTIL TIGHT. THEN ROTATE IN OPPOSITE DIRECTION ROUGHLY 3 TURNS AND ALIGN ARROWS &gt;&gt;&lt;&lt;.</p>
E.	<p>WARNING: SRS THIS AIR BAG MODULE CANNOT BE REPAIRED, DO NOT DISASSEMBLE OR TAMPER. DO NOT PERFORM DIAGNOSIS. DO NOT TOUCH WITH ELECTRICAL TEST EQUIPMENT OR PROSES. REFER TO SERVICE MANUAL FOR FURTHER INSTRUCTIONS, AND FOR SPECIAL HANDING, STORAGE AND DISPOSAL PROCEDURES. TAMPERING OR MISHANDLING CAN RESULT IN INJURY. DANGER POISON KEEP OUT OF THE REACH OF CHILDREN. CONTAINS SODIUM AZIDE AND POTASSIUM NITRATE CONTENTS ARE POISONOUS AND EXTREMELY FLAMMABLE. CONTACT WITH ACID, WATER, OR HEAVY METALS MAY PRODUCE HARMFUL AND IRRITATING GASES OR EXPLOSIVE COMPOUNDS. DO NOT DISMANTLE, INCINERATE, BRING INTO CONTACT WITH ELECTRICITY OR STORE AT TEMPERATURES EXCEEDING 200 °F (93°C). FIRST AID: IF CONTENTS ARE SWALLOWED INDUCE VOMITING. FOR EYE CONTACT FLUSH EYE WITH WATER FOR 15 MINUTES. IF GASES FORM ACID OR WATER CONTACT ARE INHALED, FRESH AIR. IN EVERY CASE, GET PROMPT MEDICAL ATTENTION.</p>
F.	<p>CAUTION: DO NOT DISASSEMBLE OR DROP. IF DEFECT REFER TO SERVICE MANUAL.</p>
G.	<p>WARNING DEATH or SERIOUS INJURY can occur</p> <ul style="list-style-type: none"> <li>• Children 12 and under can be killed by the air bag.</li> <li>• The BACK SEAT is the SAFEST place for children.</li> <li>• NEVER put a rear-facing child seat in the front.</li> <li>• Sit as far back as possible from the air bag.</li> <li>• ALWAYS use SEAT BELTS and CHILD RESTRAINS.</li> </ul> 

<b>LABEL CONTENTS</b>	
H.	<p><b>AIR BAG SYSTEM INFORMATION</b>                      THIS VEHICLE HAS AN AIR BAG SYSTEM WHICH WILL SUPPLEMENT THE SEAT BELT IN CERTAIN FRONTAL COLLISIONS. THE AIR BAG IS NOT A SUBSTITUTE FOR THE SEAT BELT IN ANY TYPE OF COLLISION. THE DRIVER AND ALL OTHER OCCUPANTS SHOULD WEAR SEAT BELTS AT ALL TIME.  <b>WARNING!</b>                      IF THE "SRS" WARNING LIGHT DOES NOT ILLUMINATE FOR SEVERAL SECONDS WHEN IGNITION KEY IS TURNED TO "ON" OR THE ENGINE IS STARTED, OR IF THE WARNING LIGHT STAYS ON WHILE DRIVING, TAKE THE VEHICLE TO YOUR NEAREST AUTHORIZED DEALER IMMEDIATELY. ALSO, IF VEHICLE'S FRONT END IS DAMAGED OR IF THE AIR BAG HAS DEPLOYED, TAKE THE VEHICLE FOR SERVICE IMMEDIATELY.                      THE AIR BAG SYSTEM MUST BE INSPECTED BY AN AUTHORIZED DEALER TEN YEARS AFTER THE VEHICLE MANUFACTURE DATE SHOWN ON THE CERTIFICATION LABEL LOCATED ON THE LEFT FRONT DOOR-LATCH POST OR DOOR FRAME.                      READ THE "SRS" SECTION OF YOUR OWNER'S MANUAL BEFORE DRIVING FOR IMPORTANT INFORMATION ABOUT OPERATION AND SERVICE OF THE AIR BAG SYSTEM.                      WHEN YOU ARE GOING TO DISCARD YOUR GAS GENERATOR OR VEHICLE, PLEASE SEE YOUR DEALER.</p>
I.	<p><b>WARNING</b>                      Children Can Be <b>KILLED</b> or <b>INJURED</b> by Passenger Air Bag. The back seat is the safest place for children 12 and under. Make sure all children use seat belts or child seat. Not to be removed except by owner.</p>
J.	<p><b>CAUTION: SRS</b>                      BEFORE REMOVAL OF STEERING GEARBOX, READ SERVICE MANUAL, CENTER FRONT WHEELS AND REMOVE IGNITION KEY. FAILURE TO DO SO MAY DAMAGE SRS CLOCK SPRING AND RENDER SRS SYSTEM INOPERATIVE, RISKING SERIOUS DRIVER INJURY.</p>
K.	<p><b>WARNING FLAMMABLE/EXPLOSIVE SRS AIR BAG MODULE</b>                      TO AVOID SERIOUS INJURY:</p> <ul style="list-style-type: none"> <li>• DO NOT REPAIR, DISASSEMBLE OR TAMPER WITH.</li> <li>• AVOID CONTACT WITH FLAME OR ELECTRICITY.</li> <li>• DO NOT USE TEST EQPT OR PROBES.</li> <li>• STORE BELOW 200°F (93°C).</li> <li>• BEFORE DOING ANY WORK INVOLVING MODULE, READ SERVICE MANUAL FOR IMPORTANT FURTHER DATA.</li> </ul>

**SCHEMATIC**

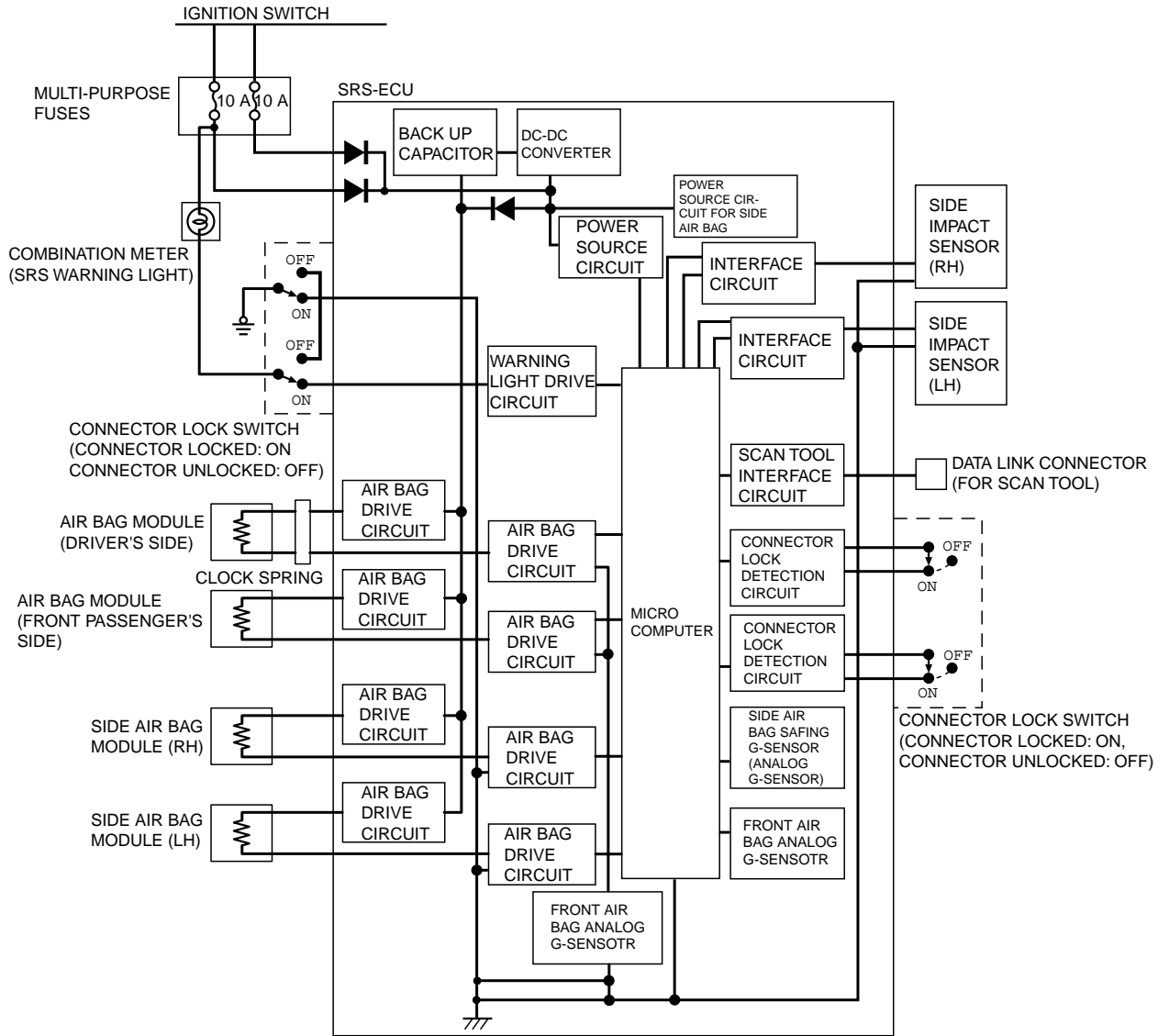

AC003555AB



**CONFIGURATION DIAGRAMS**

**DASH PANEL**

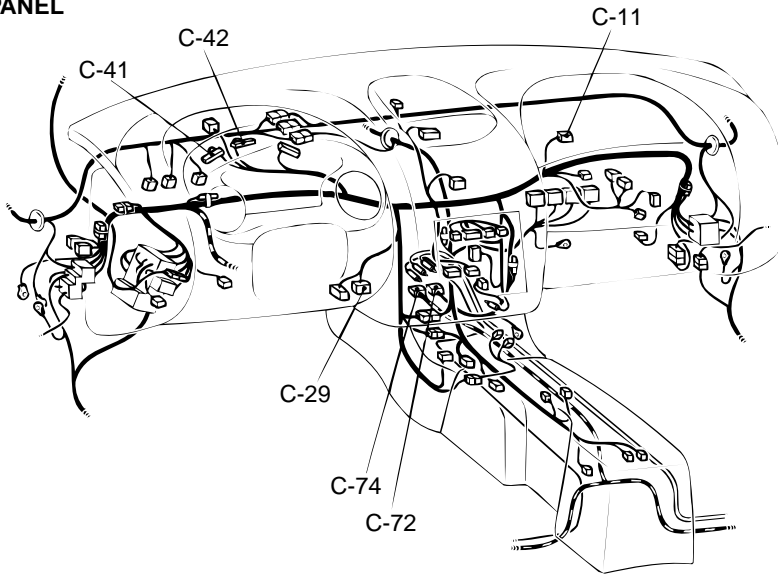

**RING COLUMN**

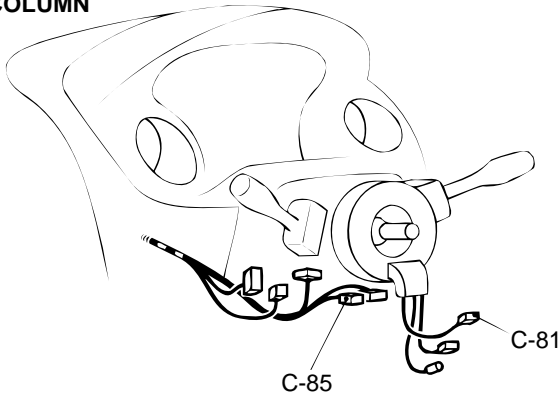

**FLOOR**

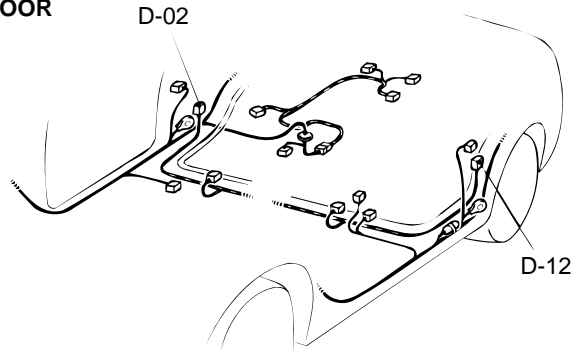

AC002963AB

- C-11** AIR BAG MODULE  
(FRONT PASSENGER'S SIDE)
- C-29** DATA LINK CONNECTOR  
(FOR SCAN TOOL)
- C-41** COMBINATION METER  
(FOR SRS WARNING LIGHT)
- C-42** COMBINATION METER  
(FOR SRS WARNING LIGHT)
- C-72** SRS-ECU
- C-74** SRS-ECU <VEHICLES WITH SRS  
SIDE AIR BAG>

- C-81** CLOCK SPRING
- C-85** AIR BAG MODULE  
(DRIVER'S SIDE)
- D-02** SIDE IMPACT SENSOR (RH)  
<VEHICLES WITH SRS SIDE AIR  
BAG>
- D-12** SIDE IMPACT SENSOR (LH)  
<VEHICLES WITH SRS SIDE  
AIR BAG>

**CIRCUIT DIAGRAM**** WARNING**

- *Do not repair, splice, or modify the SRS wiring (except for specific repairs to the front wiring harness, the instrument panel wiring harness and the side air bag wiring harness shown on [P.52B-15](#)): replace the wiring if necessary, after reading and following all precautions and procedures in this manual.*
- *Do not use an analog ohmmeter to check the SRS wiring or components; use only the special tools (refer to [P.52B-61.](#)) and a digital multi-meter (refer to [P.52B-62.](#)).*

NOTES

TSB Revision

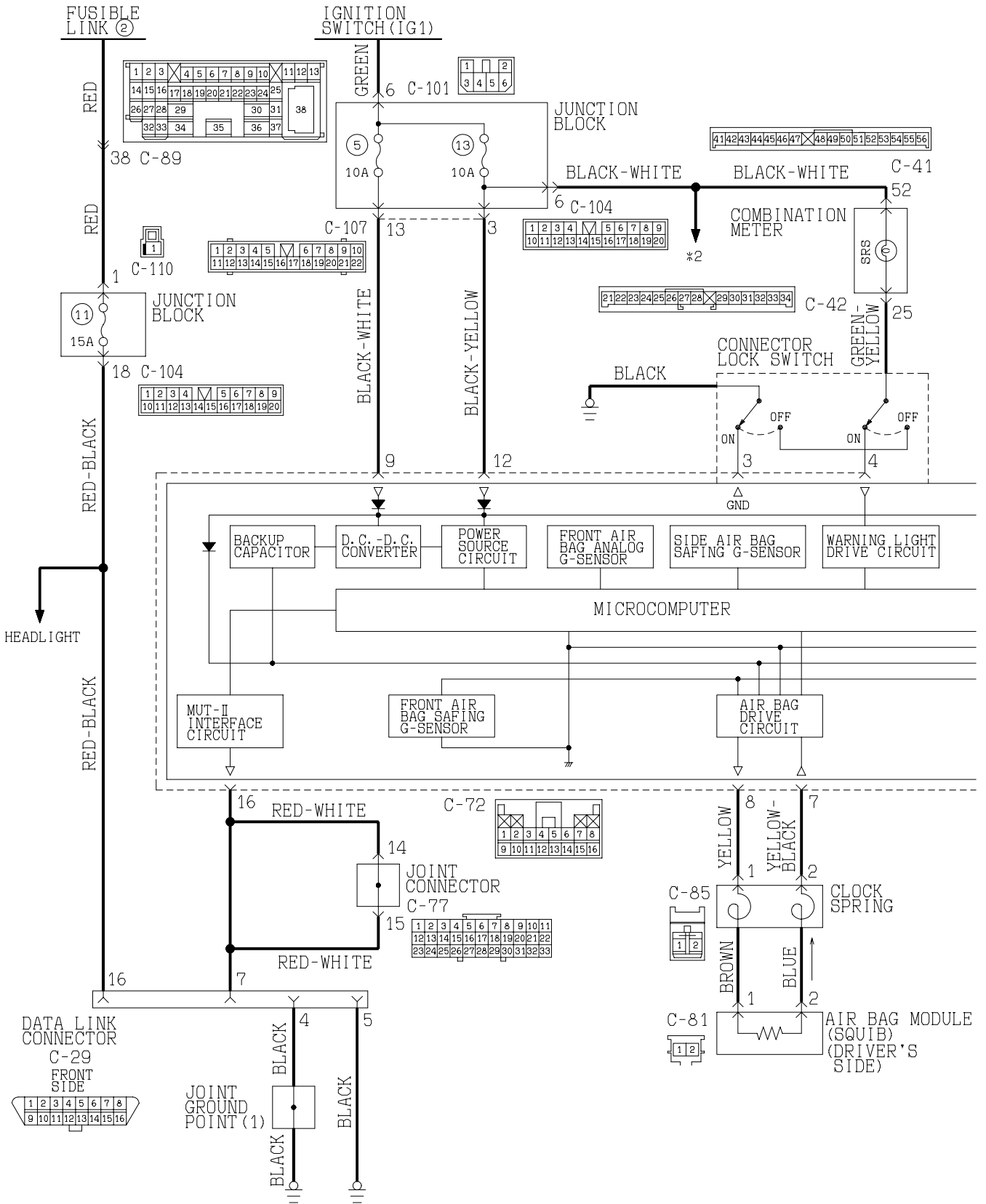

W1S01M00AA

AC003872

TSB Revision

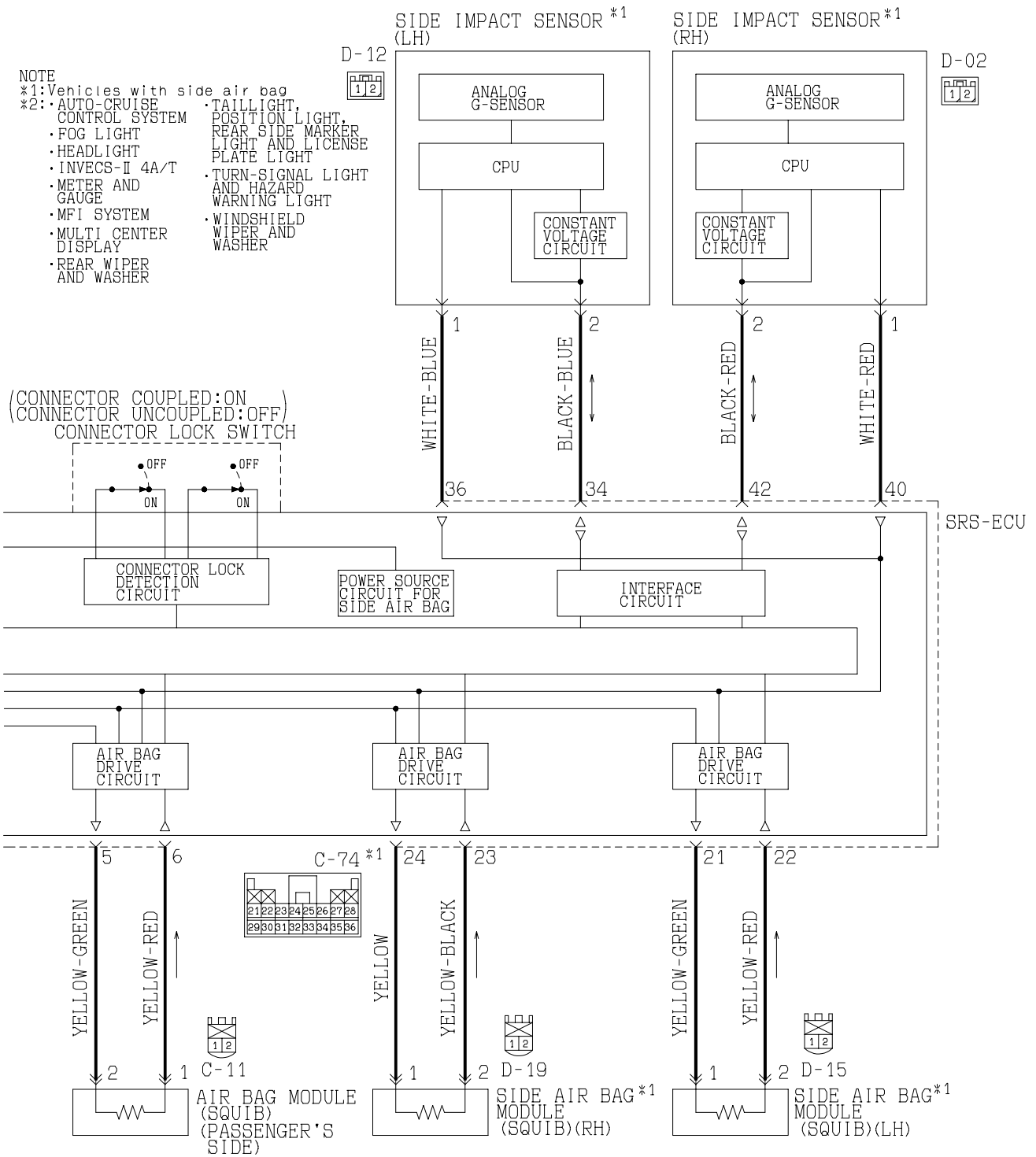

W1801M04AB  
AC003873

COMPONENT LOCATION

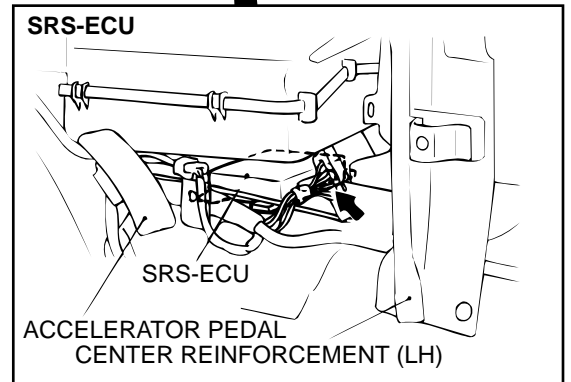
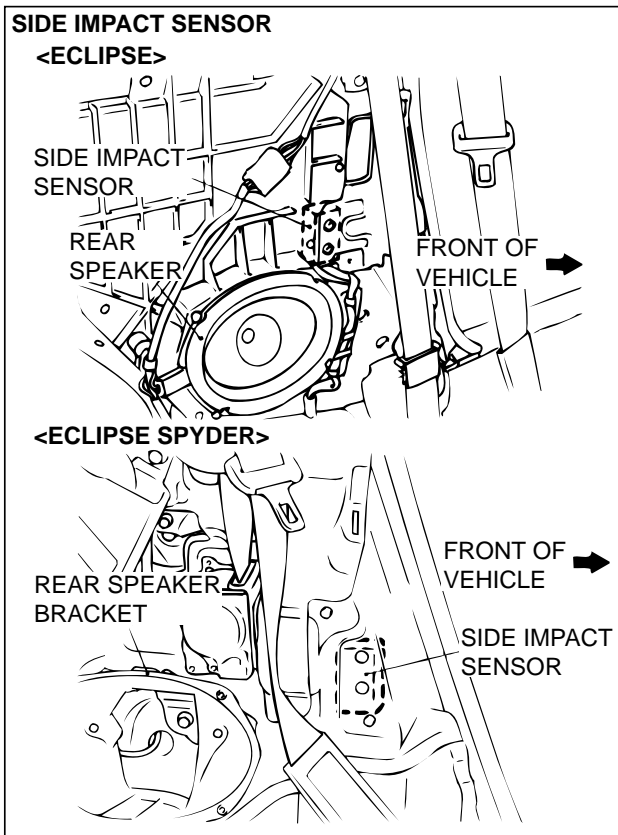
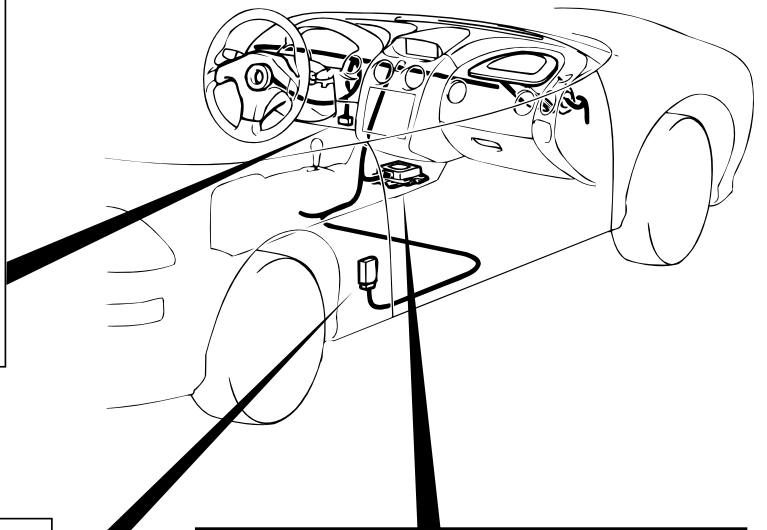
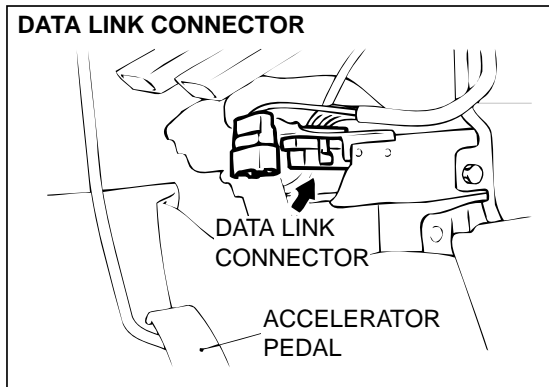

AC003020AB

**⚠ WARNING**

- **In order to avoid injury to yourself or others from accidental deployment of the air bag during servicing, read and carefully follow all the precautions and procedures described in this manual.**
- **After disconnecting the battery cable, wait 60 seconds or more before proceeding with the following work. The SRS system is designed to retain enough voltage to deploy the air bag for a short time even after the battery has been disconnected, so serious injury may result from unintended air bag deployment if work is done on the SRS system immediately after the battery cables are disconnected.**
- **Battery posts, terminals and related accessories contain lead and lead compounds. WASH HANDS AFTER HANDLING.**
- **Do not use any electrical test equipment on or near the SRS components, except those specified on [P.52B-62](#).**
- **Never Attempt to Repair the Following Components: SRS-ECU, Clock Spring, Air Bag Module, Side Impact Sensor. If any of these components are diagnosed as faulty, they should only be replaced, in accordance with the INDIVIDUAL COMPONENT SERVICE procedures in this manual, starting on page [P.52B-66](#).**
- **Do not attempt to repair the wiring harness connectors of the SRS. If any of the connectors are diagnosed as faulty, replace the wiring harness. If the wires are diagnosed as faulty, replace or repair the wiring harness according to the following table.**

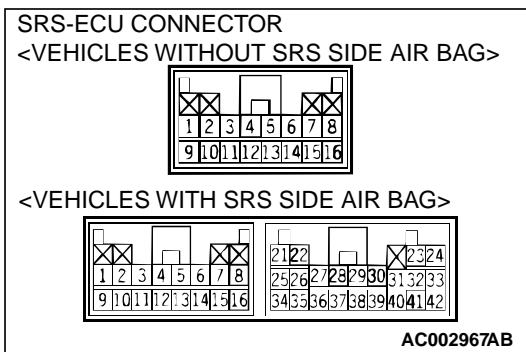
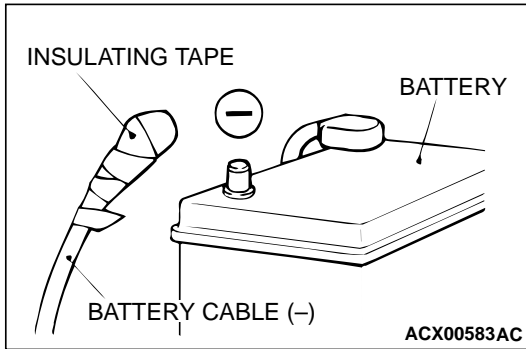

SRS-ECU TERMINAL NO.	DESTINATION OF HARNESS	CORRECTIVE ACTION
3	Body wiring harness → Ground	Correct or replace the body wiring harness.
4	Body wiring harness → Instrument panel wiring → SRS warning light	Correct or replace each wiring harness.
5, 6	Body wiring harness → Air bag module (Front passenger's side)	Correct or replace the body wiring harness.

TSB Revision

SRS-ECU TERMINAL NO.	DESTINATION OF HARNESS	CORRECTIVE ACTION
7, 8	Body wiring harness → Clock spring → Air bag module (Driver's side)	Correct or replace each wiring harness. Replace the clock spring.
9	Body wiring harness → Junction block (fuse No.5)	Correct or replace the body wiring harness.
12	Body wiring harness → Function block (fuse No.13)	Correct or replace the body wiring harness.
16	Body wiring harness → Data link connector	Correct or replace the body wiring harness.
21*, 22*	Body wiring harness → Side air bag module (LH)	Correct or replace the body wiring harness.
23*, 24*	Body wiring harness → Side air bag module (RH)	Correct or replace the body wiring harness.
34*, 35*, 36*	Body wiring harness → Floor wiring harness → Side impact sensor (LH)	Correct or replace each wiring harness.
40*, 41*, 42*	Body wiring harness → Floor wiring harness → Side impact sensor (RH)	Correct or replace each wiring harness.

NOTE: \*Vehicles with side air bags

**⚠ WARNING**

- **Inspection of the SRS-ECU connector harness should be carried out by the following procedure. Insert the backprobing tool into connector from harness side, and connect the tester to backprobing tool. If any tool other than backprobing tool is used, it may cause damage to the harness and other components. Furthermore, measurement should not be carried out by touching the backprobing tool directly against the terminals from the front of the connector. The terminals are plated to increase their conductivity, so if they are touched directly by the backprobing tool, the plating may break, which will decrease reliability.**
- **The SRS components should not be subjected to heat over 93°C (200°F), so remove the SRS-ECU, air bag module, and clock spring before drying or baking the vehicle after painting.**
- **After servicing the SRS system, check the warning light operation to make sure that the system functions properly. (Refer to P.52B-3.)**
- **Make certain that the ignition switch is "LOCK" (OFF) position when the scan tool is connected or disconnected.**
- **If you have any questions about the SRS system, please contact the MMSA Tech Line.**

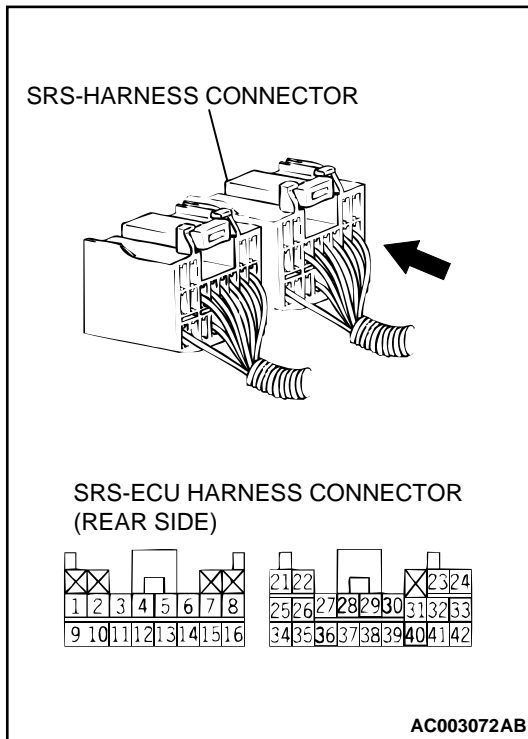



## SRS AIR BAG DIAGNOSIS

### INTRODUCTION TO DIAGNOSIS

The SRS system is controlled by the SRS-ECU. The SRS-ECU judges how severe a collision is by detecting signals from the analog G-sensor. If the impact is over a predetermined level, the SRS-ECU outputs an ignition signal. At this time, if the safing G-sensor is on, the SRS air bag will inflate. The SRS warning light in the combination meter alerts a malfunction of the SRS system. If the following symptoms occur even when the vehicle has not been in a collision, there may be a malfunction in the SRS system.

M1524005000073

- The SRS warning light does not go off within approximately 7 seconds after the ignition switch has been turned "ON".
- The SRS warning light does not illuminate when the ignition switch is turned "ON".

Refer to the Post-collision Diagnosis when inspecting and servicing the vehicle that has been in a collision (Refer to [P.52B-62.](#)).

### TROUBLESHOOTING STRATEGY

Use these steps to plan your diagnostic strategy. If you follow them carefully, you will be sure that you have exhausted all of the possible ways to find a SRS fault.

M1524003100074

1. Gather information about the problem from the customer.
2. Verify that the condition described by the customer exists.
3. Check the vehicle for any SRS DTC.
4. If you cannot verify the condition but there are no SRS DTCs, the malfunction is intermittent. Refer to GROUP 00, How to use Troubleshooting – Inspection Service Points – How to Cope with Intermittent Malfunctions [P.00-6.](#)
5. If there is a SRS DTC, record the code number, then erase the code from vehicle memory using scan tool MB991502.
6. Recreate the SRS DTC set conditions to see if the same SRS DTC will set again.
  - If the same SRS DTC sets again, follow the Inspection Chart for DTC and find the fault.
  - If you cannot get the same SRS DTC to set again, the malfunction is intermittent. Refer to GROUP 00, How to use Troubleshooting – Inspection Service Points – How to Cope with Intermittent Malfunctions [P.00-6.](#)

### SRS DTC DIAGNOSIS

M1524003200071

#### Required Special Tool:

- MB991502: Scan Tool (MUT-II)

#### **CAUTION**

To prevent damage to scan tool MB991502, always turn the ignition switch to "LOCK" (OFF) position before connecting or disconnecting scan tool MB991502.

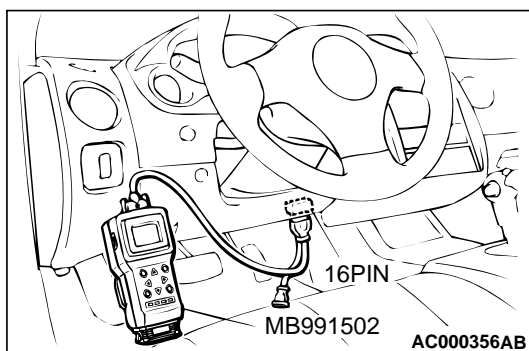

### RETRIEVING SRS DTC

Connect scan tool MB991502 to the data link connector, and then check DTC.

### ERASING SRS DTC

Connect scan tool MB991502 to the data link connector, and then erase the DTC.

## DTC CHART

M1524003300119

Inspect according to the inspection chart that is appropriate for the DTC.

CODE NO.	ON-BOARD DIAGNOSTIC ITEM	REFERENCE PAGE
14	Analog G-sensor system in the SRS-ECU	P.52B-20
15	Safing G-sensor short circuit	P.52B-20
16	Safing G-sensor open circuit	P.52B-20
17	Safing G-sensor for side air bag faults	P.52B-20
21*2	Driver's side air bag module (squib) system fault 1	P.52B-22
22*2	Driver's side air bag module (squib) system fault 2	P.52B-22
24*2	Front passenger's side air bag module (squib) system fault 1	P.52B-26
25*2	Front passenger's side air bag module (squib) system fault 2	P.52B-26
31	SRS-ECU capacitor circuit voltage too high	P.52B-20
32	SRS-ECU capacitor circuit voltage too low	P.52B-20
34*1	Connector lock system detects connector unlocked	P.52B-29
35	SRS-ECU air bag condition monitor detects deployed air bag	P.52B-29
41*1	IG1 power circuit system (fuse No.13 circuit)	P.52B-30
42*1	IG1 power circuit system (fuse No.5 circuit)	P.52B-30
43	SRS warning light drive circuit system fault 1	Light does not illuminate*1
		Light does not switch off
44*1	SRS warning light drive circuit system fault 2	P.52B-33
45	SRS-ECU non-volatile memory (EEPROM) and A/D converter system	P.52B-20
51	Driver's side air bag module (squib ignition drive circuit) system detected short circuit	P.52B-20
52	Driver's side air bag module (squib ignition drive circuit) system detected open circuit	P.52B-20
54	Front passenger's side air bag module (squib ignition drive circuit) system detected short circuit	P.52B-20
55	Passenger (front)-side air bag module (squib ignition drive circuit) system detected short circuit	P.52B-20
61	Driver's side air bag module (squib) system fault for power supply circuit	P.52B-22
62	Driver's side air bag module (squib) system fault for ground circuit	P.52B-22
64	Passenger (front) side-air bag module (squib) system fault for power supply circuit	P.52B-26
65	Passenger (front) side-air bag module (squib) system fault for ground circuit	P.52B-26
71*2	Right hand side-air bag module (squib) system fault 1	P.52B-37
72*2	Right hand side-air bag module (squib) system fault 2	P.52B-37

<b>CODE NO.</b>	<b>ON-BOARD DIAGNOSTIC ITEM</b>	<b>REFERENCE PAGE</b>
73	Right hand side-air bag module (squib) system detected short circuit	P.52B-20
74	Right hand side-air bag module (squib) system detected open circuit	P.52B-20
75	Right hand side-air bag module (squib) system fault power supply circuit	P.52B-37
76	Right hand side-air bag module (squib) system fault ground circuit	P.52B-37
79	Left hand side-air bag module (squib) system fault 5 for power supply circuit	P.52B-39
81*2	Left hand side-air bag module (squib) system fault 1	P.52B-42
82*2	Left hand side-air bag module (squib) system fault 2	P.52B-42
83	Left hand side-air bag module (squib) system fault 3 for ignition drive circuit	P.52B-20
84	Left hand side-air bag module (squib) system fault 4 for ignition drive circuit	P.52B-20
85	Left hand side-air bag module (squib) system fault power supply circuit	P.52B-42
86	Left hand side-air bag module (squib) system fault ground circuit	P.52B-42
89	Right hand side-air bag module (squib) system fault 5 for power supply circuit	P.52B-45
91*1	Left hand side-impact sensor power supply circuit system	P.52B-48
92	Left hand side-impact sensor system for fault 1	P.52B-51
93	Left hand side-air bag module (squib) system fault 6 for communication system	P.52B-39
94*1	Right hand side-impact sensor power supply circuit system	P.52B-52
95	Right hand side-impact sensor system for fault 1	P.52B-51
96	Right hand side-air bag module (squib) system fault 6 for communication system	P.52B-45

**NOTE:**

1. \*1: If the vehicle condition returns to normal, the DTC will be automatically erased, and the SRS warning light will return to normal.
2. \*2: However, if no DTC resets, the SRS warning light will be switched off (The DTC will be retained).  
<Vehicles without SRS side air bag>
3. If the vehicle has a discharged battery, it will store the DTC 41 or 42. When these DTC are read, check the battery condition.

## SYMPTOM CHART

M1524003400116

SYMPTOMS	INSPECTION PROCEDURE NO.	REFERENCE PAGE
Communication with scan tool MB991502 is not possible (Communication with all systems is not possible).	-	GROUP 13A, DIAGNOSIS <a href="#">P.13A-339</a> GROUP 13B, DIAGNOSIS <a href="#">P.13B-411</a>
Communication with scan tool MB991502 is not possible (Communication is not possible with SRS only).	1	<a href="#">P.52B-57</a>
When the ignition switch is turned to "ON" (engine stopped), the SRS warning light does not illuminate.	Refer to DTC No. 43.	<a href="#">P.52B-33</a>
After the ignition switch is turned to "ON," the SRS warning light does not go off within approximately 7 seconds.	Refer to DTC No. 43.	<a href="#">P.52B-33</a>

## DIAGNOSTIC TROUBLE CODE PROCEDURES

**DTC 14: Analog G-sensor system in the SRS-ECU****DTC 15: Safing G-sensor short circuit****DTC 16: Safing G-sensor open circuit****DTC 17: Safing G-sensor for side air bag faults****DTC 31: SRS-ECU capacitor circuit voltage too high****DTC 32: SRS-ECU capacitor circuit voltage too low****DTC 45: SRS-ECU non-volatile memory (EEPROM) and A/D converter system****DTC 51: Driver's side air bag module (squib ignition drive circuit) system detected short circuit****DTC 52: Driver's side air bag module (squib ignition drive circuit) system detected open circuit****DTC 54: Passenger (front)-side air bag module (squib ignition drive circuit) system detected short circuit****DTC 55: Passenger (front)-side air bag module (squib ignition drive circuit) system detected open circuit****DTC 73: Right hand side-air bag module (squib) system detected short circuit****DTC 74: Right hand side-air bag module (squib) system detected open circuit****DTC 83: Left hand side-air bag module (squib) system fault 3 for ignition drive circuit****DTC 84: Left hand side-air bag module (squib) system fault 4 for ignition drive circuit****DTC SET CONDITIONS**

- These DTC are output when a fault is detected in the SRS-ECU. The most likely causes for this code to be set are shown in the table below:

**TROUBLESHOOTING HINTS**

- Malfunction of the SRS-ECU

CODE NO.	DEFECTIVE PART	SYMPTOMS
14	Analog G-sensor	<ul style="list-style-type: none"> <li>• When the analog G-sensor is not operating</li> <li>• When the characteristics of the analog G-sensor are abnormal</li> <li>• When the output from the analog G-sensor is abnormal</li> </ul>
15	Safing G-sensor (front air bag)	• Short circuit in the safing G-sensor
16		• Open circuit in the safing G-sensor

TSB Revision

<b>CODE NO.</b>	<b>DEFECTIVE PART</b>	<b>SYMPTOMS</b>
17	Safing G-sensor (side air bag)	<ul style="list-style-type: none"> <li>• When the safing G-sensor is not operating</li> <li>• When the characteristics of the safing G-sensor are abnormal</li> <li>• When the output from the safing G-sensor is abnormal</li> </ul>
31	Capacitor	<ul style="list-style-type: none"> <li>• Voltage at the capacitor terminal is higher than the specified value for five seconds or more</li> </ul>
32		<ul style="list-style-type: none"> <li>• Voltage at the capacitor terminal is lower than the specified value for five seconds or more (This is not detected if diagnostic trouble code No. 41 or 42 indicating battery positive voltage drop has been output.)</li> </ul>
45	Non-volatile memory (EEPROM) and A/D converter	<ul style="list-style-type: none"> <li>• When the non-volatile memory (EEPROM) and A/D converter system are abnormal</li> </ul>
51	Driver's side air bag module (squib ignition drive circuit)	<ul style="list-style-type: none"> <li>• Short circuit in the squib ignition drive circuit</li> </ul>
52		<ul style="list-style-type: none"> <li>• Open circuit in the squib ignition drive circuit</li> </ul>
54	Front passenger's side air bag module (squib ignition drive circuit)	<ul style="list-style-type: none"> <li>• Short circuit in the squib ignition drive circuit</li> </ul>
55		<ul style="list-style-type: none"> <li>• Open circuit in the squib ignition drive circuit</li> </ul>
73	Side air bag module (RH) (squib ignition drive circuit)	<ul style="list-style-type: none"> <li>• Short circuit in the squib ignition drive circuit</li> </ul>
74		<ul style="list-style-type: none"> <li>• Open circuit in the squib ignition drive circuit</li> </ul>
83	Side air bag module (LH) (squib ignition drive circuit)	<ul style="list-style-type: none"> <li>• Short circuit in the squib ignition drive circuit</li> </ul>
84		<ul style="list-style-type: none"> <li>• Open circuit in the squib ignition drive circuit</li> </ul>

**DIAGNOSIS**

Replace the SRS-ECU. Refer to [P.52B-66](#).

**Q: Is any of DTC output?**

**YES** : There is no action to be taken

**NO** : This diagnosis is complete.

- DTC 21 : Driver's side air bag module (squib) system fault 1  
 DTC 22: Driver's side air bag module (squib) system fault 2  
 DTC 61: Driver's side air bag module (squib) system fault for power supply circuit  
 DTC 62: Driver's side air bag module (squib) system fault for ground circuit

Driver's Side Air Bag Module (Squib) Circuit

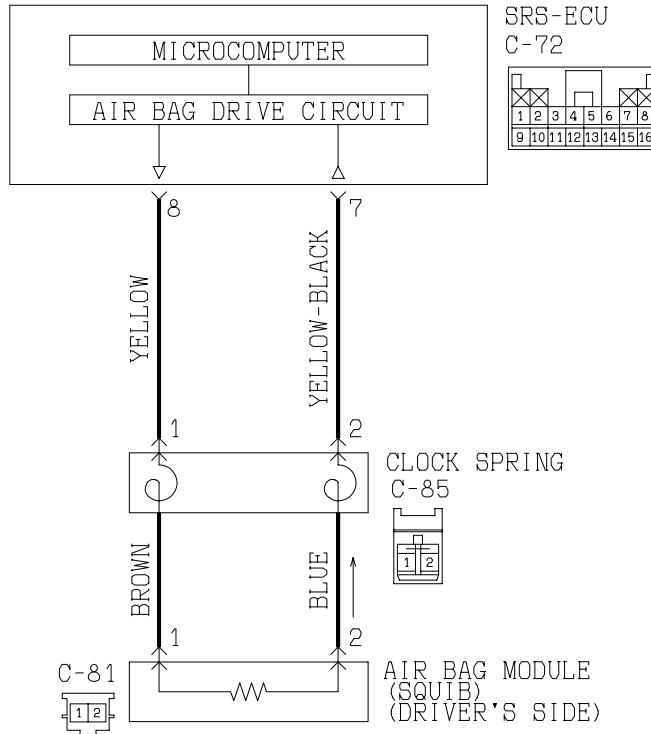

W0S15M04A

AC003877AB

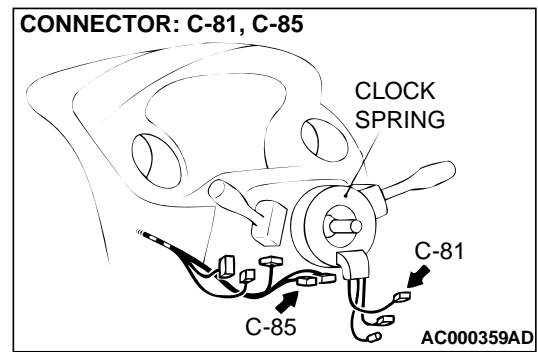
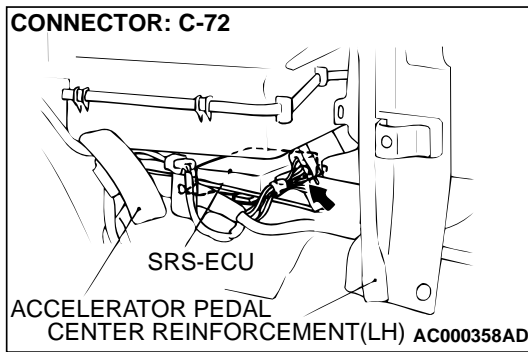

CIRCUIT OPERATION

- The SRS-ECU judges how severe a collision is by detecting signals from the left and right side impact sensors and the analog G-sensor. If the impact is over a predetermined level, the SRS-ECU outputs an ignition signal. At this time, if the safing G-sensor is on, the SRS air bag will inflate.
- The ignition signal is input to the air bag module via the clock spring to inflate the air bag.

DTC SET CONDITIONS

- These DTC are output if there is abnormal resistance between the input terminals of the driver's side air bag module (squib). The most likely causes for this code to be set are shown in the table below: However, if no DTC resets, the SRS warning light will be switched off (The DTC will be retained). <Vehicles without SRS side air bag>

TSB Revision

**TROUBLESHOOTING HINTS**

- Malfunction of the clock spring
- Damaged wiring harnesses or connectors
- Malfunction of the driver's side air bag module (squib)
- Malfunction of the SRS-ECU

CODE NO.	SYMPTOMS
21	<ul style="list-style-type: none"> <li>• Short circuit in driver's side air bag module (squib) or harness</li> <li>• Short circuit in clock spring</li> </ul>
22	<ul style="list-style-type: none"> <li>• Open circuit in driver's side air bag module (squib) or harness</li> <li>• Open circuit in clock spring</li> <li>• Malfunction of connector contact</li> </ul>
61	<ul style="list-style-type: none"> <li>• Short circuit in driver's side air bag module (squib) harness leading to the power supply</li> </ul>
62	<ul style="list-style-type: none"> <li>• Short circuit in driver's side air bag module (squib) harness leading to the ground</li> </ul>

**DIAGNOSIS**

**Required Special Tools:**

- MB991502: Scan Tool (MUT-II)
- MB991613: SRS Check Harness

**STEP 1. Check the clock spring connector C-81**

(1) Remove the air bag module mounting equipment and check clock spring connector C-81. At this time, check that there is no gap at place B shown in the illustration. (Refer to P.52B-69.)

**Q: Are connectors correctly connected?**

**YES :** Go to Step 2.

**NO :** Insert connector to the place, where there remains no gap at place B shown in the illustration. Then go to Step 5.

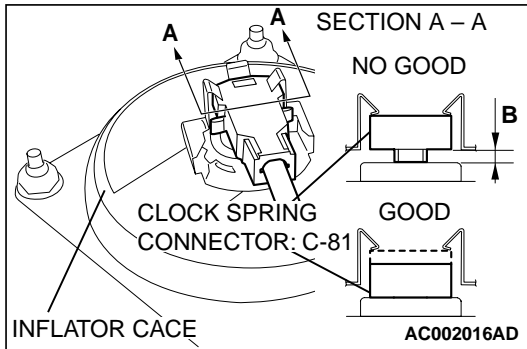

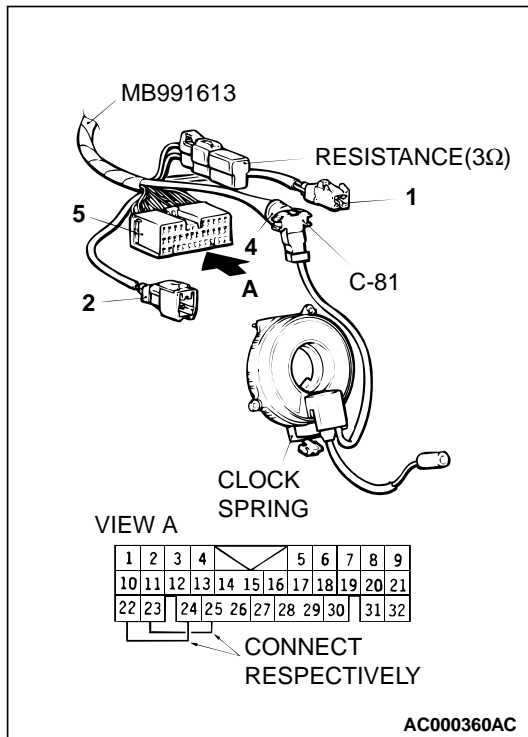
**STEP2. Check the driver's side air bag module line using the scan tool and MB991613 SRS Check harness.**

- (1) Remove the driver's side air bag module.(Refer to P.52B-69.)
- (2) Connect connector (4) of special tool MB991613 to clock spring connector C-81.
- (3) Connect connector (1) of special tool MB991613 to connector (2).
- (4) Connect terminals 22 to 24, and terminals 23 to 25 of special tool MB991613 connector (5).
- (5) Connect the clock spring to the body wiring harness.
- (6) Connect the negative battery terminal.
- (7) Erase the DTC memory.

**Q: Is any of code number 21, 22, 61 or 62 output?****YES :** Go to Step 3.**NO :** Replace the driver's side air bag module. Refer to. Then go to Step 5.**STEP 3. Check the clock spring.**

- (1) Check the connectors and protective tube for damaged, and the terminal for deformation.
- (2) Visually check the case for damaged.

**Q: Is any malfunction found on the clock spring?****YES :** Replace the clock spring. Refer to P.52B-69. Then go to Step 5.**NO :** Go to Step 4.



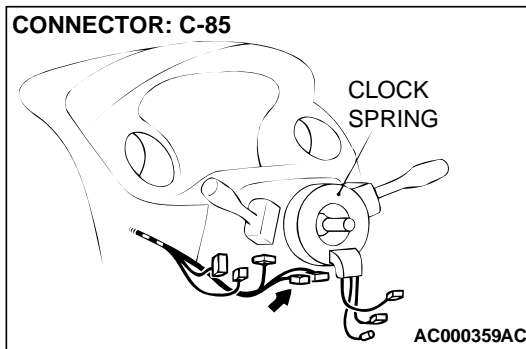
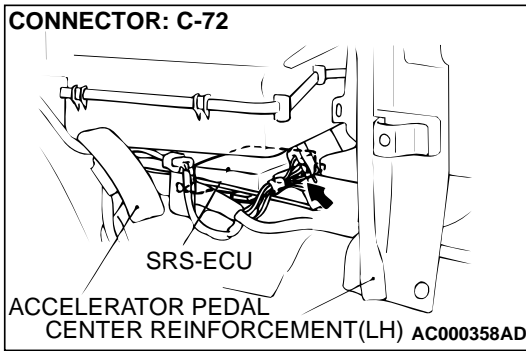

**STEP 4. Check the harness wires between SRS-ECU connector C-72 and clock spring connector C-85.**

**Q: Are the harness wires between SRS-ECU connector C-72 and clock spring connector C-85 in good condition?**

**YES :** Go to Step 5.

**NO :** Repair the harness wires between SRS-ECU connector C-72 and clock spring connector C-85. Then go to Step 5.

**STEP 5. Check the DTC.**

**Q: Is any of DTC 21, 22, 61 or 62 output?**

**YES :** Return to Step 1.

**NO :** This diagnosis is complete. (If no malfunctions are not found in all steps, an intermittent malfunction is suspected. Refer to GROUP 00, How to Use Troubleshooting/Inspection Service Points – How to Cope with Intermittent Malfunction [P.00-6.](#))

- DTC 24: Passenger (front) side-air bag module (squib) system fault 1
- DTC 25: Passenger (front) side-air bag module (squib) system fault 2
- DTC 64: Passenger (front) side-air bag module (squib) system fault for power supply circuit
- DTC 65: Passenger (front) side-air bag module (squib) system fault for ground circuit

Front Passenger's Side Air Bag Module (Squib) Circuit

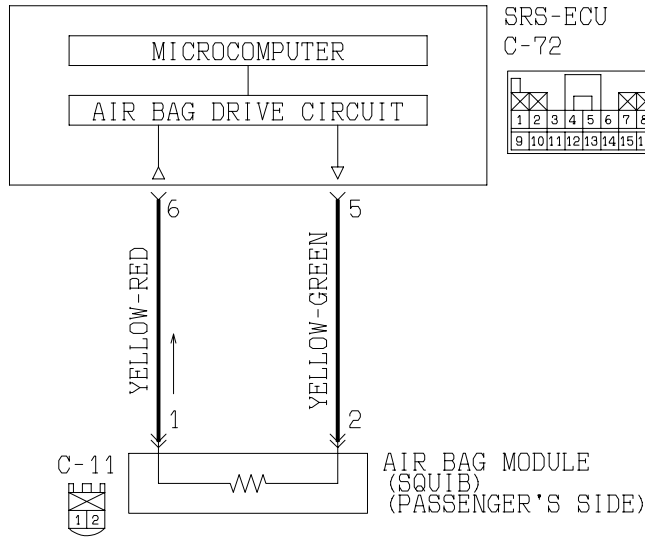

W0815M05A

AC003882AB

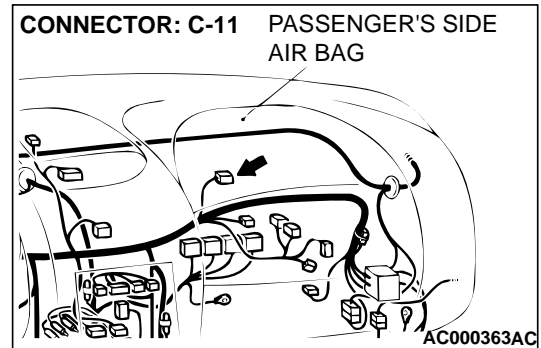
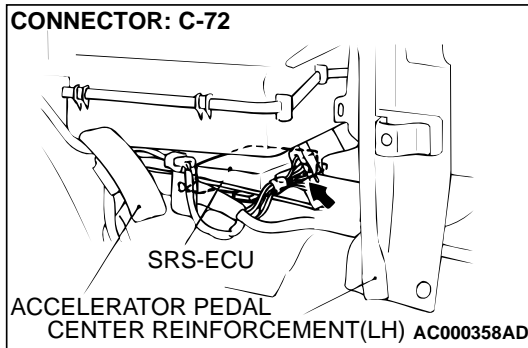

**CIRCUIT OPERATION**

- The SRS-ECU judges how severe a collision is by detecting signals from the left and right side impact sensors and the analog G-sensor. If the impact is over a predetermined level, the SRS-ECU outputs an ignition signal. At this time, if the safing G-sensor is on, the SRS air bag will inflate.
- The ignition signal is input to the air bag module to inflate the air bag.

**DTC SET CONDITIONS**

- These DTC are output if there is abnormal resistance between the input terminals of the front passenger's side air bag module (squib). The most likely causes for this code to be set are shown in the table below: However, if no DTC resets, the SRS warning light will be switched off (The DTC will be retained). <Vehicles SRS side air bag>

**TROUBLESHOOTING HINTS**

- Damaged wiring harnesses or connectors
- Malfunction of the front passenger's side air bag module (squib)
- Malfunction of the SRS-ECU

TSB Revision

CODE NO.	SYMPTOMS
24	<ul style="list-style-type: none"> <li>• Short circuit in front passenger's side air bag module (squib) or harness</li> </ul>
25	<ul style="list-style-type: none"> <li>• Open circuit in front passenger's side air bag module (squib) or harness</li> <li>• Malfunction of connector contact</li> </ul>
64	<ul style="list-style-type: none"> <li>• Short circuit in front passenger's side air bag module (squib) harness leading to the power supply</li> </ul>
65	<ul style="list-style-type: none"> <li>• Short circuit in front passenger's side air bag module (squib) harness leading to the ground</li> </ul>

**DIAGNOSIS**

**Required Special Tools:**

- MB991502: Scan Tool (MUT-II)
- MB991613: SRS Check Harness

**STEP 1. Check the front passenger's side air bag module line using the scan tool and MB991613 SRS Check harness.**

- (1) Disconnect front passenger's side air bag module connector C-11.
- (2) Connect special tool MB991613 connector (1).
- (3) Connect the negative battery terminal.
- (4) Erase the DTC memory.

**Q: Is the DTC output?**

**YES** : Go to Step 2.

**NO** : Replace the front passenger's side air bag module. Refer to [P.52B-69](#). Then go to Step 3.

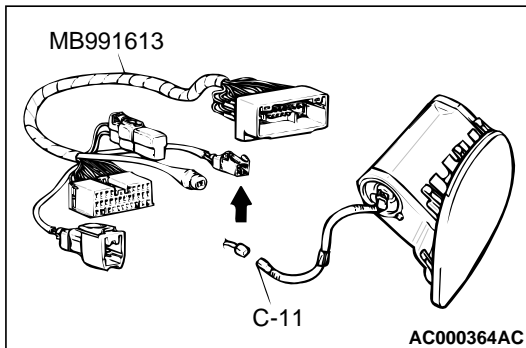

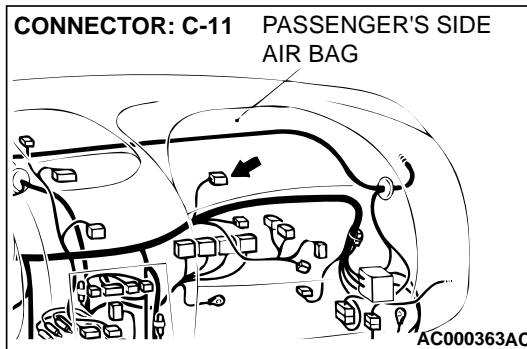
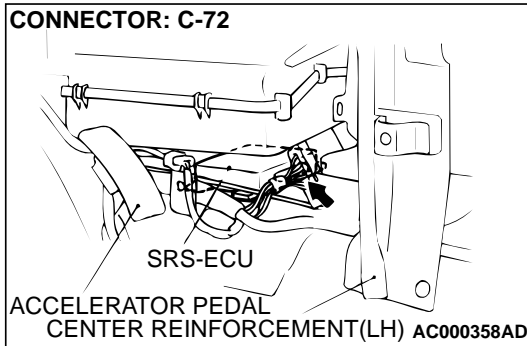

**STEP 2. Check the harness wires between SRS-ECU connector C-72 and front passenger's side air bag module connector C-11.**

**Q: Are the harness wires between SRS-ECU connector C-72 and front passenger's side air bag module connector C-11 in good condition?**

**YES :** Go to Step 3.

**NO :** Repair them. Then go to Step 3.

**STEP 3. Check for DTC.**

**Q: Is any of DTC 24, 25, 64 or 65 output?**

**YES :** Replace the SRS-ECU. Refer to [P.52B-66](#).

**NO :** This diagnosis is complete. (If no malfunctions are not found in all steps, an intermittent malfunction is suspected. Refer to GROUP 00, How to Use Troubleshooting/Inspection Service Points – How to Cope with Intermittent Malfunction [P.00-6](#).)

**DTC 34: Connector lock system detects connector unlocked**

**DTC SET CONDITIONS**

- This DTC is output if a poor connection at the SRS-ECU is detected. However, if the vehicle condition returns to normal, DTC number 34 will be automatically erased, and the SRS warning light will go out.

**TROUBLESHOOTING HINTS**

- Damaged connectors
- Malfunction of the SRS-ECU

**DIAGNOSIS**

**STEP 1. Check SRS-ECU connector C-72 <Vehicles without SRS side air bag>, C-72, C-74 <Vehicles with SRS side air bag> for damage. If SRS-ECU connector C-72 <Vehicles without SRS side air bag>, C-72, C-74 <Vehicles with SRS side air bag> are damaged, repair or replace them.**

**Q: Are SRS-ECU connector C-72 <Vehicles without SRS side air bag>, C-72, C-74 <Vehicles with SRS side air bag> in good condition?**

**YES :** Replace the SRS-ECU. Refer to [P.52B-66](#). Then go to Step 2.

**NO :** Repair or replace them. Refer to GROUP 00E, Harness Connector Inspection [P.00E-2](#). Then go to Step 2.

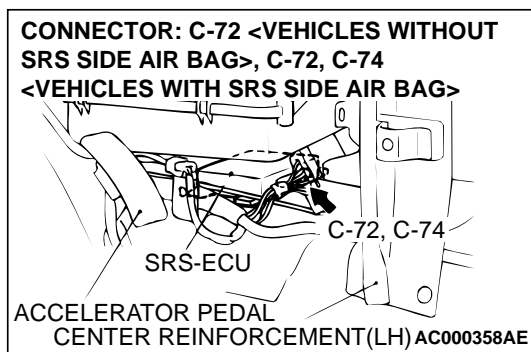

**STEP 2. Check for DTC.**

**Q: Is DTC 34 output?**

**YES :** There is no action to be taken

**NO :** This diagnosis is complete. (If no malfunctions are not found in all steps, an intermittent malfunction is suspected. Refer to GROUP 00, How to Use Troubleshooting/Inspection Service Points – How to Cope with Intermittent Malfunction [P.00-6](#).)

**DTC 35: SRS-ECU air bag condition monitor detects deployed air bag**

**DTC SET CONDITIONS**

- This DTC is output after the air bag has deployed. If this code is output before the air bag has deployed, the cause is probably a malfunction inside the SRS-ECU.

**TROUBLESHOOTING HINTS**

- Malfunction of the SRS-ECU

**DIAGNOSIS**

Replace the SRS-ECU. Refer to [P.52B-66](#).

**Q: Is DTC 35 output?**

**YES :** There is no action to be taken

**NO :** This diagnosis is complete.

DTC 41: IG1 power circuit system (fuse No.13 circuit)  
DTC 42: IG1 power circuit system (fuse No.5 circuit)

IG1 Power Circuit (fuse No.13 circuit or No.15 circuit)

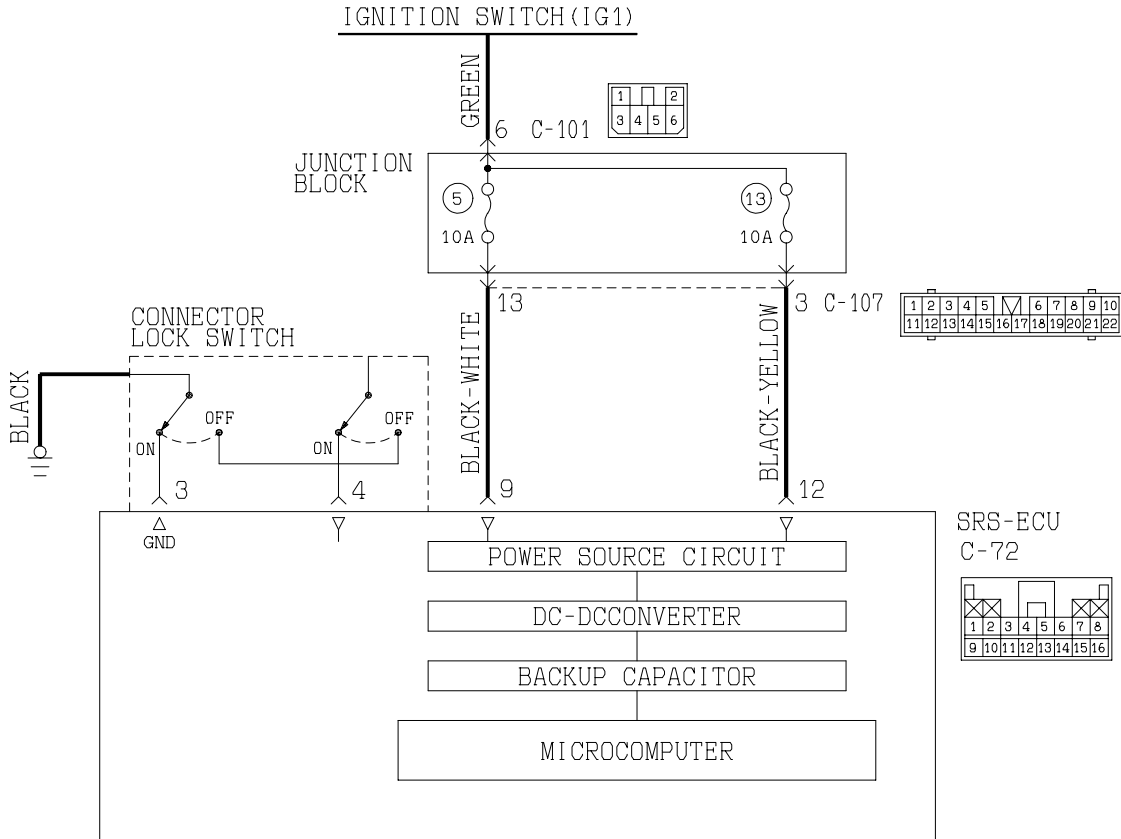

W0S15M06A  
AC003883AB

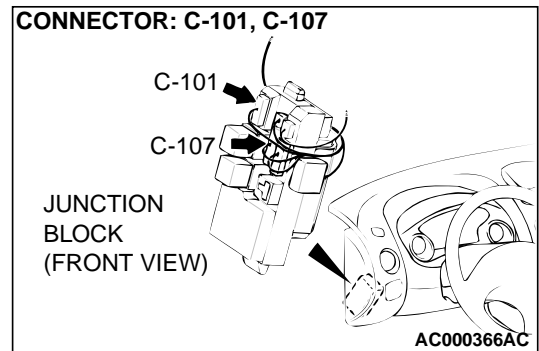
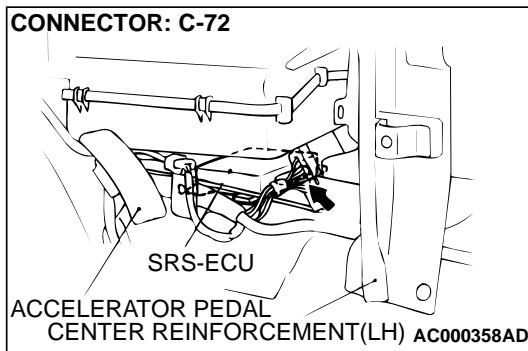

CIRCUIT OPERATION

- The SRS-ECU is powered from the ignition switch (IG1).
- The SRS-ECU power is supplied from two circuits. Even if one circuit is shut off, the air bag can inflate.
- The SRS-ECU judges how severe a collision is by detecting signals from the left and right side impact sensors and the analog G-sensor. If the impact is over a predetermined level, the SRS-ECU outputs an ignition signal. At this time, if the safing G-sensor is on, the SRS air bag will inflate.

TSB Revision

**DTC SET CONDITIONS**

- These DTC are output if the voltage between the IG1 terminals (fuse No.13 or No.5 circuit) and ground is lower than a predetermined value for a continuous period of five second or more. However, if the vehicle condition returns to normal, DTC numbers 41 or 42 will be automatically erased, and the SRS warning light will switch off.

**TROUBLESHOOTING HINTS**

- Damaged wiring harnesses or connectors
- Malfunction of the SRS-ECU

**DIAGNOSIS**

**STEP 1. Check the ignition switch (IG1) line at the SRS-ECU connector C-72 by backprobing.**

- (1) Do disconnect the connector C-72.
- (2) Connect the negative battery terminal.
- (3) Turn the ignition switch to "ON" position.
- (4) Measure the voltage between terminal 12 (for DTC 41) or 9 (for DTC 42) and the ground by backprobing.
  - Voltage should be 9 volts or more

**Q: Is the voltage 9 volts or more?**

- YES :** Go to Step 3.  
**NO :** Go to Step 2.

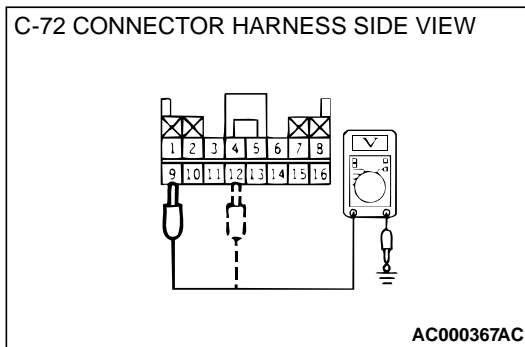

**STEP 2. Check the harness wires between the ignition switch (IG1) and SRS-ECU connector C-72.**

*NOTE: After inspecting intermediate connectors C-101 and C-107, inspect the wiring harness. If intermediate connectors are damaged, repair or replace them. Refer to GROUP 00E, Harness Connector Inspection P.00E-2. Then go to Step 5.*

**Q: Are harness wires between the ignition switch (IG1) and SRS-ECU connector C-72 in good condition?**

- YES :** Go to Step 5.  
**NO :** Repair them. Then go to Step 5.

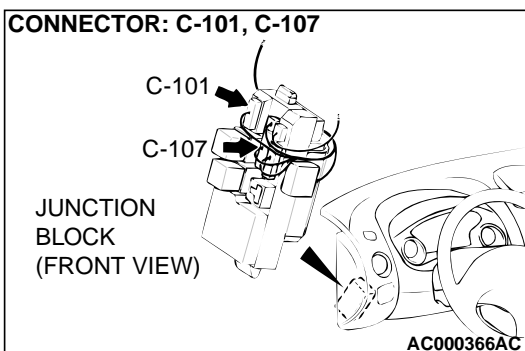
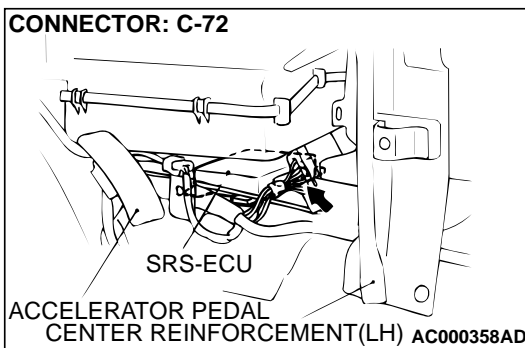

C-72 CONNECTOR HARNESS SIDE VIEW

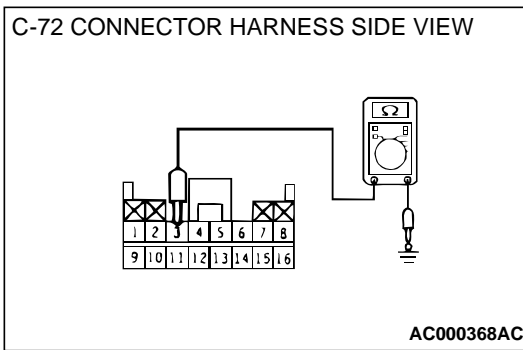
**STEP 3. Check the ground line at the SRS-ECU connector C-72 by backprobing.**

- (1) Do not disconnect the connector C-72.
- (2) Measure the resistance between terminal 3 and ground by backprobing.

**Q: Is the resistance between terminal 3 and ground less than 2 ohm?**

**YES :** Replace the SRS-ECU. Refer to [P.52B-66](#). Then go to Step 5.

**NO :** Go to Step 4.

**STEP 4. Check the harness wires between SRS-ECU connector C-72 and ground.**

**Q: Are the harness wires between SRS-ECU connector C-72 and ground in good condition?**

**YES :** Go to Step 5.

**NO :** Repair them. Then go to Step 5.

CONNECTOR: C-72

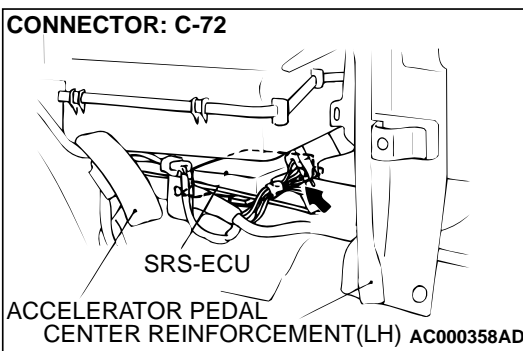
**STEP 5. Check for DTC.**

**Q: Is any of DTC 41 or 42 output?**

**YES :** Replace the SRS-ECU. Refer to [P.52B-66](#).

**NO :** This diagnosis is complete. (If no malfunctions are not found in all steps, an intermittent malfunction is suspected. Refer to GROUP 00, How to Use Troubleshooting/Inspection Service Points – How to Cope with Intermittent Malfunction [P.00-6](#).)



**DTC 43: SRS warning light drive circuit system fault 1 (Light does not illuminate.)/SRS warning light drive circuit system fault 1 (Light does not switch off.)**

**DTC 44: SRS warning light drive circuit system fault 2**

**SRS Warning Light Drive Circuit**

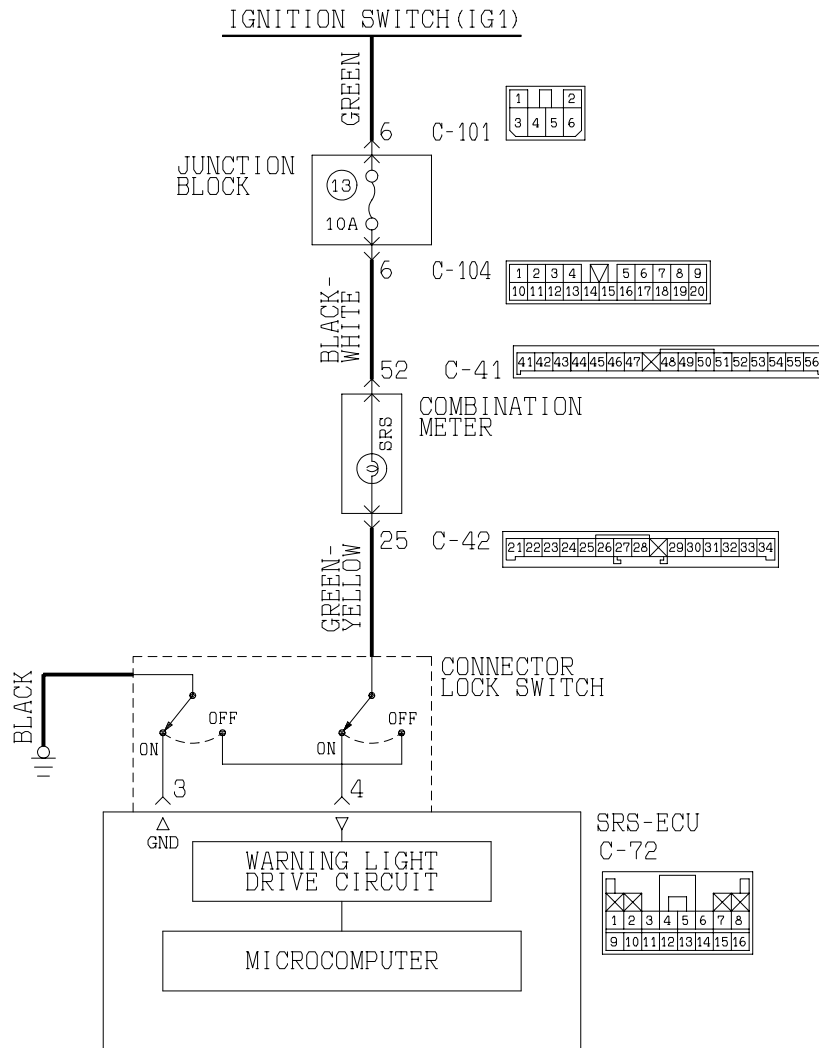

W0S15M07A

AC003884AB

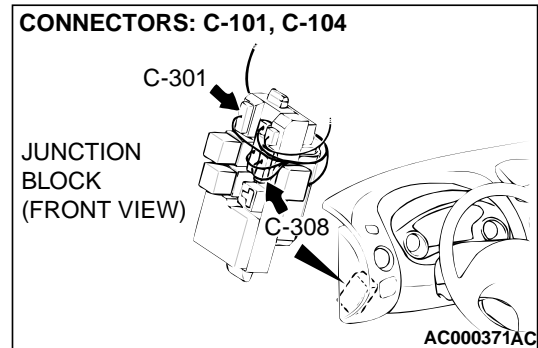
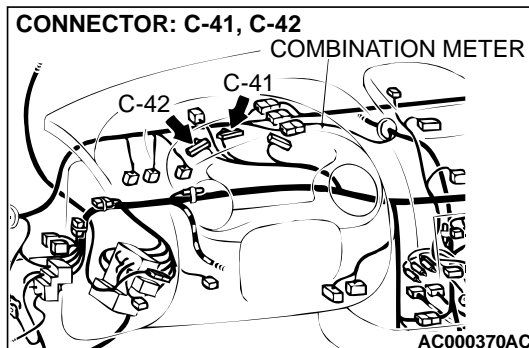

**TSB Revision**

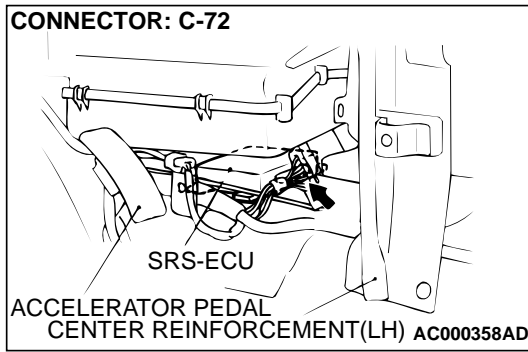

**CIRCUIT OPERATION**

- Power for the SRS warning light is supplied from the ignition switch (IG1) circuit.
- The SRS warning light illuminates when the ignition switch is turned "ON" and goes out after approximately 7 seconds if there is not a malfunction in the SRS system.
- The SRS-ECU judges how severe a collision is by detecting signals from the left and right side impact sensors and the analog G-sensor. If the impact is over a predetermined level, the SRS-ECU outputs an ignition signal. At this time, if the safing G-sensor is on, the SRS air bag will inflate.

**DTC SET CONDITIONS**

- This DTC is output when an open circuit is detected for a continuous period of five seconds while the SRS-ECU is monitoring the SRS warning light and the light is OFF. (transistor OFF.) However, if the vehicle condition returns to normal, DTC 43 will be automatically erased, and the SRS warning light will go out.

- This DTC is output when a short to ground occurs in the harness between the SRS warning light and SRS-ECU while SRS-ECU is monitoring the light and the light is ON.
- This DTC is output under one of the following cases while the SRS-ECU is monitoring the warning light drive circuit:
  - When a short circuit occurs in the warning light drive circuit.
  - When a malfunction is detected in the output transistor inside the SRS-ECU.

However, if the vehicle returns to normal condition, DTC 44 will be automatically erased, and the SRS warning light will go out.

**TROUBLESHOOTING HINTS**

- Damaged wiring harnesses of connectors
- Blown bulb (for DTC 43)
- Malfunction of the SRS-ECU
- Malfunction of the combination meter (for DTC 43)

**DIAGNOSIS**

**STEP 1. Check the SRS warning light line at SRS-ECU connector C-72 by backprobing.**

- (1) Do disconnect the connector C-72.
- (2) Connect the negative battery cable.
- (3) Turn the ignition switch to "ON" position.
- (4) Connect terminal 4 to ground by backprobing.
  - The SRS warning light should illuminate.

**Q: Does the SRS warning light illuminate?**

- YES :** Replace the SRS-ECU. Refer to [P.52B-66](#). Then go to Step 6.
- NO :** Go to Step 2.

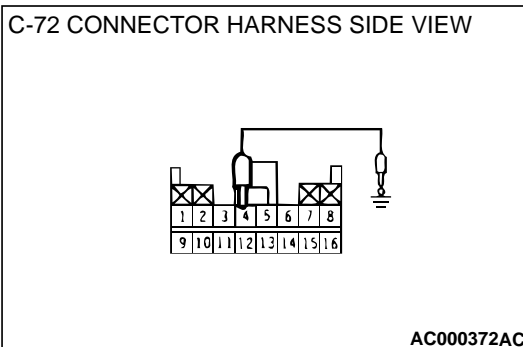

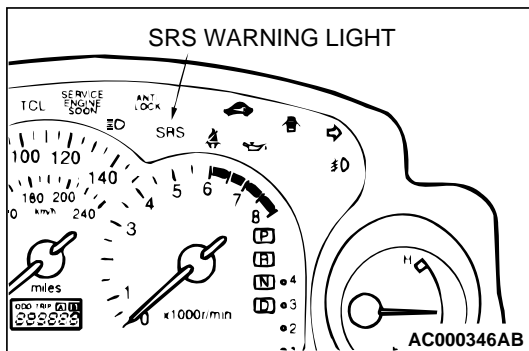

**STEP 2. Check the SRS warning light bulb.**

**Q: Has the SRS warning light bulb blown?**

**YES :** Replace the SRS warning light bulb. Then go to Step 6.

**NO :** Go to Step 3.

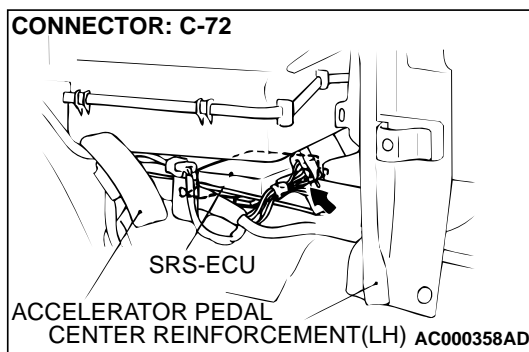

**STEP 3. Check the harness wires between the ignition switch (IG1) and SRS-ECU connector C-72.**

**NOTE:** After inspecting intermediate connectors C-41, C-42, C-101, C-104 inspect the wiring harness. If intermediate connectors C-41, C-42, C-101, C-104 are damaged, repair or replace them. Refer to GROUP 00E, Harness Connector Inspection P.00E-2. Then go to Step 6.

**Q: Are the harness wires between the ignition switch (IG1) and SRS-ECU connector C-72 in good condition?**

**YES :** Go to Step 4.

**NO :** Repair them. Then go to Step 6.

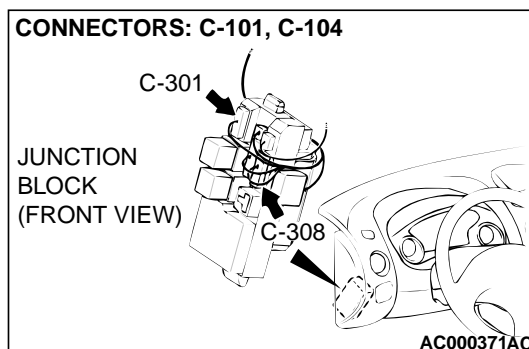
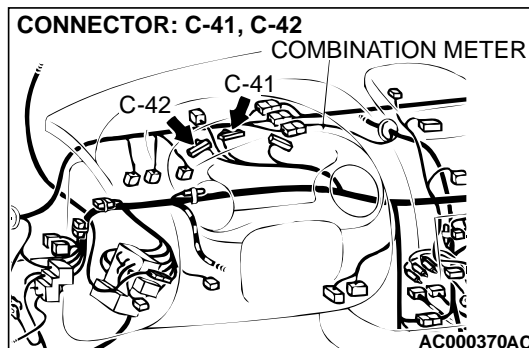

C-72 CONNECTOR HARNESS SIDE VIEW

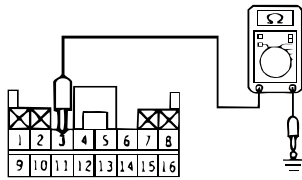

AC000368AC

**STEP 4. Check the ground line at the SRS-ECU connector C-72 by backprobing.**

- (1) Do not disconnect the connector C-72.
- (2) Measure the resistance between terminal 3 and ground by backprobing.
  - Should be less than 2 ohm.

**Q: Is the resistance between terminal 3 and ground less than 2 ohm?****YES :** Go to Step 6.**NO :** Go to Step 5.

CONNECTOR: C-72

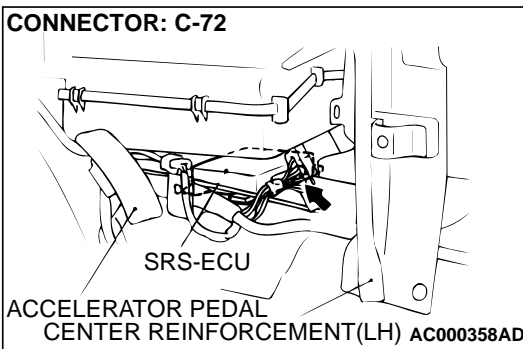
ACCELERATOR PEDAL  
CENTER REINFORCEMENT(LH) AC000358AD**STEP 5. Check the harness wires between SRS-ECU connector C-72 and ground.****Q: Are the harness wires between SRS-ECU connector C-72 and ground in good condition?****YES :** Go to Step 6.**NO :** Repair them. Then go to Step 6.**STEP 6. Check for DTC.****Q: Is any of DTC 43 or 44 output?****YES :** There is no action to be taken.**NO :** This diagnosis is complete. (If no malfunctions are not found in all steps, an intermittent malfunction is suspected. Refer to GROUP 00, How to Use Troubleshooting/Inspection Service Points – How to Cope with Intermittent Malfunction [P.00-6.](#))

- DTC 71: Right side-air bag module (squib) system fault 1**  
**DTC 72: Right side-air bag module (squib) system fault 2**  
**DTC 75: Right side-air bag module (squib) system fault power supply circuit**  
**DTC 76: Right side-air bag module (squib) system fault ground circuit**

**Side Air Bag Module (RH) (Squib) Circuit**

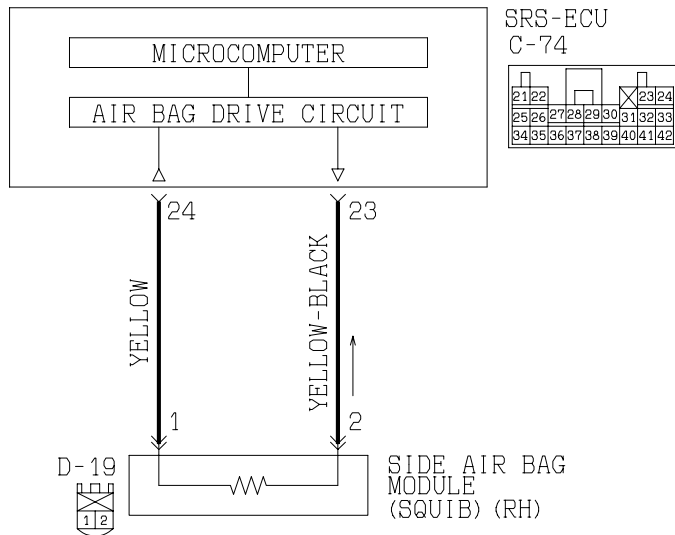

W0S15M08A

AC003885AB

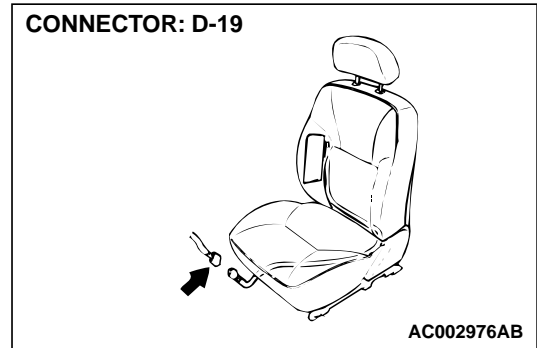
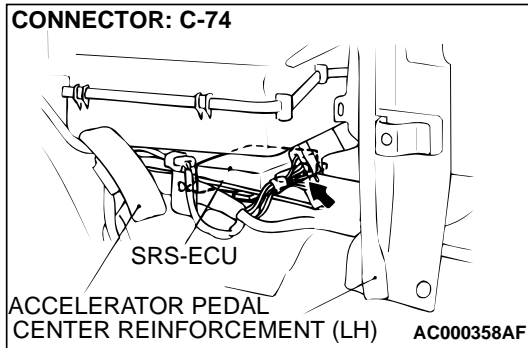

**CIRCUIT OPERATION**

- The SRS-ECU judges how severe a collision is by detecting signals from the left and right side impact sensors and the analog G-sensor. If the impact is over a predetermined level, the SRS-ECU outputs an ignition signal. At this time, if the safing G-sensor is on, the SRS air bag will inflate.
- The ignition signal is input to the air bag module to inflate the air bag.

**DTC SET CONDITIONS**

- These DTC are output if there is abnormal resistance between the input terminals of the side air bag module (RH) (squib). The most likely causes for this code to be set are shown in the table below:

**TROUBLESHOOTING HINTS**

- Damaged wiring harnesses or connectors
- Malfunction of the side air bag module (RH) (squib)
- Malfunction of the SRS-ECU

DTC	SYMPTOMS
71	<ul style="list-style-type: none"> <li>Short circuit in side air bag module (RH) (squib) or harness</li> </ul>
72	<ul style="list-style-type: none"> <li>Open circuit in side air bag module (RH) (squib) or harness</li> <li>Malfunction of connector contact</li> </ul>
75	<ul style="list-style-type: none"> <li>Short circuit in side air bag module (RH) (squib) harness leading to the power supply</li> </ul>
76	<ul style="list-style-type: none"> <li>Short circuit in side air bag module (RH) (squib) harness leading to the ground</li> </ul>

**DIAGNOSIS**

**Required Special Tools:**

- MB991502: Scan Tool (MUT-II)
- MB991613: SRS Check Harness

**STEP 1. Check the side air bag module line using the scan tool and MB991613 SRS Check harness.**

- (1) Disconnect side air bag module (RH) connector D-19.
- (2) Connect special tool MB991613 connector (1).
- (3) Connect the negative battery terminal.
- (4) Erase the DTC memory.

**Q: Is DTC 71, 72, 75 or 76 output?**

**YES :** Go to Step 2.

**NO :** Replace the seat back assembly of the front seat (RH). Refer to GROUP 52A, Front Seat P.52A-18. Then go to Step 3.

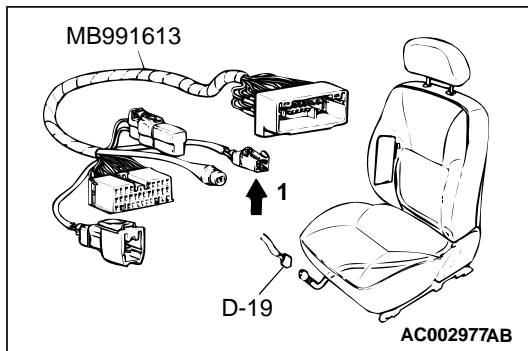

**STEP 2. Check the harness wires between SRS-ECU connector C-74 and side air bag module (RH) connector D-19**

**Q: Are the harness wires between SRS-ECU connector C-74 and side air bag module (RH) connector D-19 in good condition?**

**YES :** Go to Step 3.

**NO :** Repair them. Then go to Step 3.

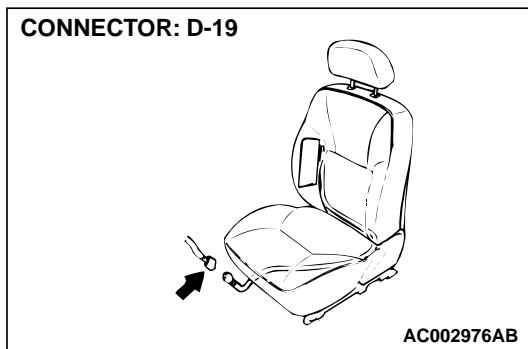
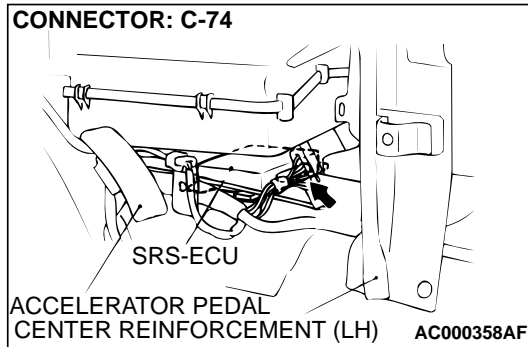

**STEP 3. Check for DTC.**

**Q: Is any of DTC 71, 72, 75 or 76 output?**

**YES :** Replace the SRS-ECU. Refer to P.52B-66.

**NO :** This diagnosis is complete.(If no malfunctions are not found in all steps, an intermittent malfunction is suspected. Refer to GROUP 00, How to Use Troubleshooting/Inspection Service Points – How to Cope with Intermittent Malfunction P.00-6.)

**DTC 79: Left hand side-air bag module (squib) system fault 5 for power supply circuit**  
**DTC 93: Left hand side-air bag module (squib) system fault 6 for communication system**

**Side Impact Sensor (LH) Circuit**

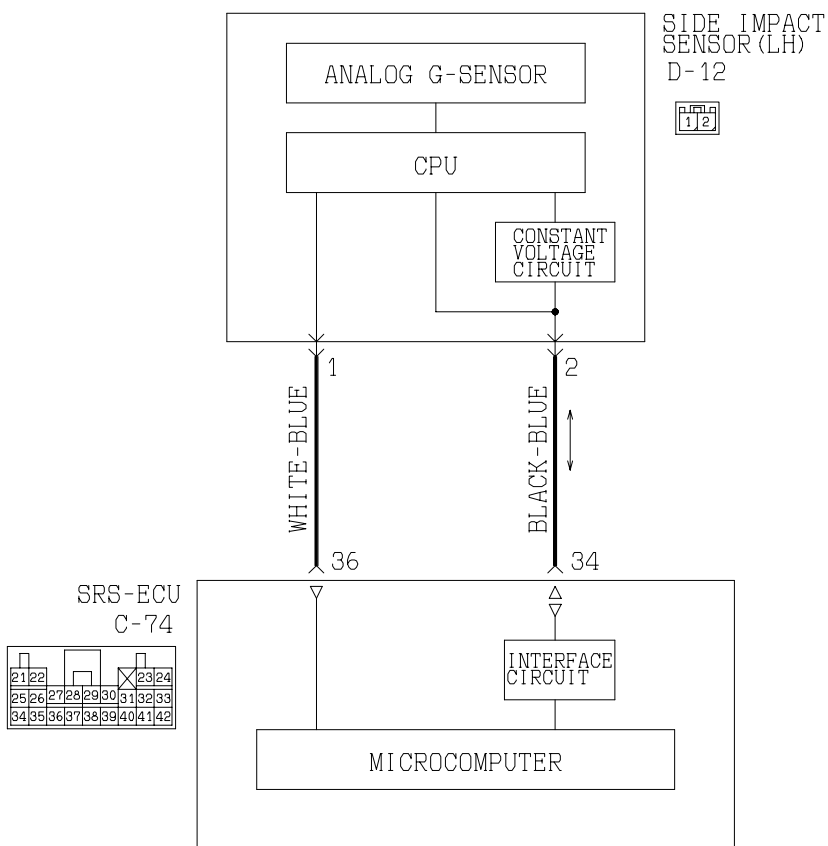

W1S01M01AA

AC003886AB

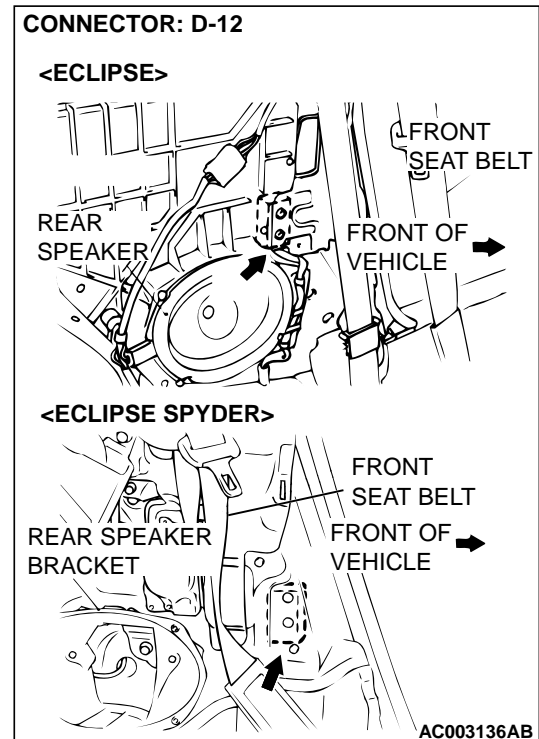
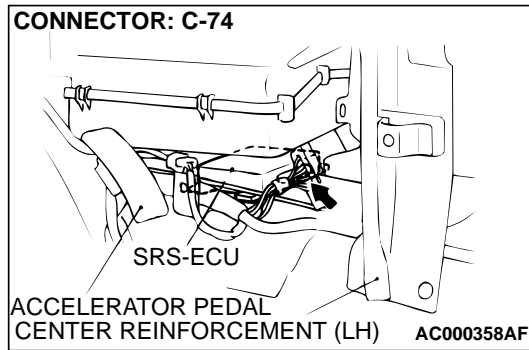

### CIRCUIT OPERATION

- The SRS-ECU judges how severe a collision is by detecting signals from the left and right side impact sensors and the analog G-sensor. If the impact is over a predetermined level, the SRS-ECU outputs an ignition signal. At this time, if the safing G-sensor is on, the SRS air bag will inflate.

### DTC SET CONDITIONS

- These DTC are output if communication between the side impact sensor (LH) and the SRS-ECU is not possible or communication is faulty.

### TROUBLESHOOTING HINTS

- Damaged wiring harnesses or connectors
- Malfunction of the side impact sensor (LH)
- Malfunction of the SRS-ECU

### DIAGNOSIS

#### Required Special Tool:

- MB991502: Scan Tool (MUT-II)

#### STEP 1. Check the side impact sensor

- Replace the side impact sensor (LH) with the side impact sensor (RH).
- Connect the negative battery terminal.
- Erase DTC memory.

#### Q: Is DTC 79 or 93 erased or DTC 89 or 96 output?

**YES** : Replace the side impact sensor (LH) with a new one.  
Refer to [P.52B-76](#). Then go to Step 3.

**NO** : Go to Step 2.



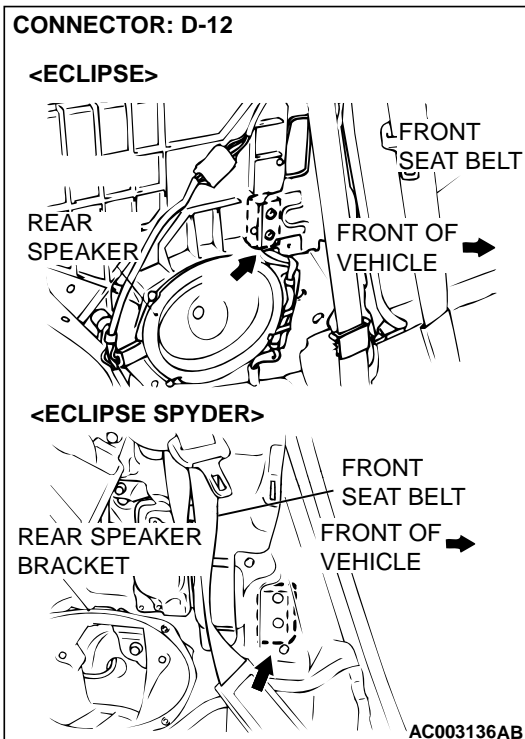
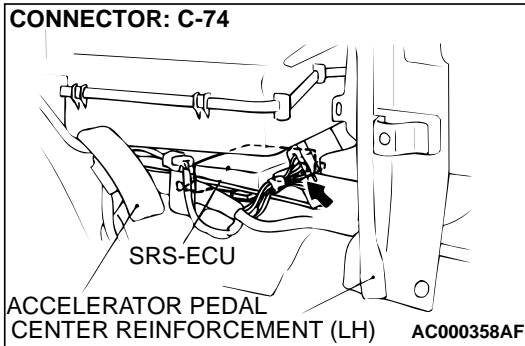

**STEP 2. Check the harness wires between SRS-ECU connector C-74 and side impact sensor (LH) connector D-12.**

**Q: Are the harness wires between SRS-ECU connector C-74 and side impact sensor (LH) connector D-12 in good condition?**

**YES :** Go to Step 3.

**NO :** Repair them. Then go to Step 3.

**STEP 3. Check for DTC.**

**Q: Is any of DTC 79 or 93 output?**

**YES :** Replace the SRS-ECU. Refer to [P.52B-66](#).

**NO :** This diagnosis is complete. (If no malfunctions are not found in all steps, an intermittent malfunction is suspected. Refer to GROUP 00, How to Use Troubleshooting/Inspection Service Points – How to Cope with Intermittent Malfunction [P.00-6](#).)

- DTC 81: Left hand side-air bag module (squib) system fault 1  
 DTC 82: Left hand side-air bag module (squib) system fault 2  
 DTC 85: Left hand side-air bag module (squib) system fault power squib circuit  
 DTC 86: Left hand side-air bag module (squib) system fault ground circuit

Side Air Bag Module (LH) (Squib) Circuit

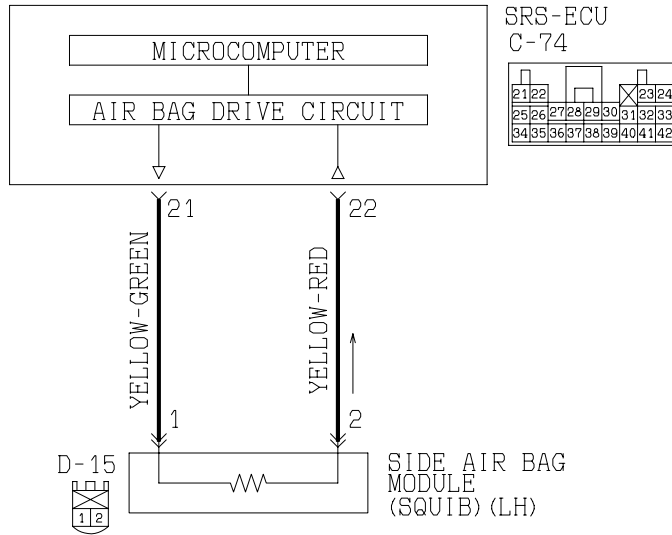

W0S15M10A

AC002964AB

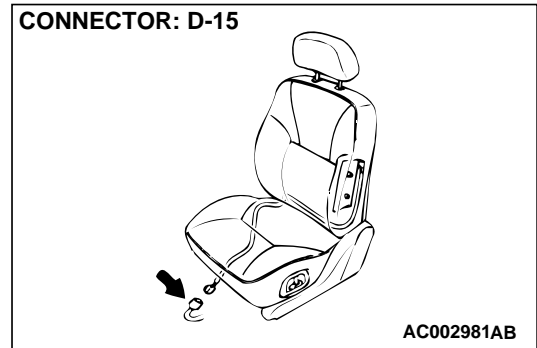
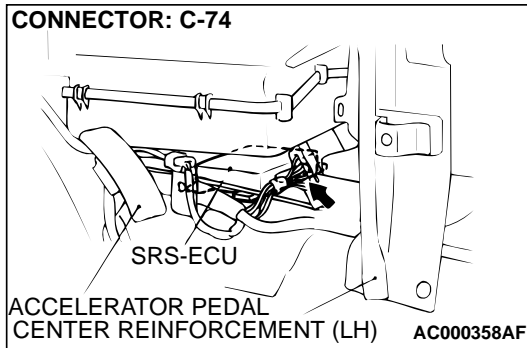

**CIRCUIT OPERATION**

- The SRS-ECU judges how severe a collision is by detecting signals from the left and right side impact sensors and the analog G-sensor. If the impact is over a predetermined level, the SRS-ECU outputs an ignition signal. At this time, if the safing G-sensor is on, the SRS air bag will inflate.
- The ignition signal is input to the air bag module to inflate the air bag.

**DTC SET CONDITIONS**

- These DTC are output if communication between the side impact sensor (LH) and the SRS-ECU is not possible or communication is faulty.

**TROUBLESHOOTING HINTS**

- Damaged wiring harnesses or connectors
- Malfunction of the side impact sensor (LH)
- Malfunction of the SRS-ECU

<b>DTC</b>	<b>SYMPTOMS</b>
81	<ul style="list-style-type: none"> <li>• Short circuit in side air bag module (LH) (squib) or harness</li> </ul>
82	<ul style="list-style-type: none"> <li>• Open circuit in side air bag module (LH) (squib) or harness</li> <li>• Malfunction of connector contact</li> </ul>
85	<ul style="list-style-type: none"> <li>• Short circuit in side air bag module (LH) (squib) harness leading to the power supply</li> </ul>
86	<ul style="list-style-type: none"> <li>• Short circuit in side air bag module (LH) (squib) harness leading to ground</li> </ul>

**DIAGNOSIS**

**Required Special Tool:**

- MB991502: Scan Tool (MUT-II)
- MB991613: SRS Check Harness

**STEP 1. Check the side air bag module line using the scan tool and MB991613 SRS Check harness.**

- (1) Disconnect side air bag module (LH) connector D-15.
- (2) Connect special tool MB991613 connector (1).
- (3) Connect the negative battery terminal.
- (4) Erase DTC memory.

**Q: Is any of DTC 81, 82, 85 or 86 output?**

**YES :** Go to Step 2.

**NO :** Replace the seat back assembly of the front seat (LH). Refer to GROUP 52A, Front Seat [P.52A-18](#). Then go to Step 3.

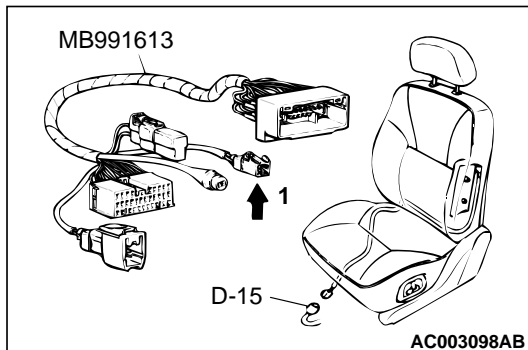

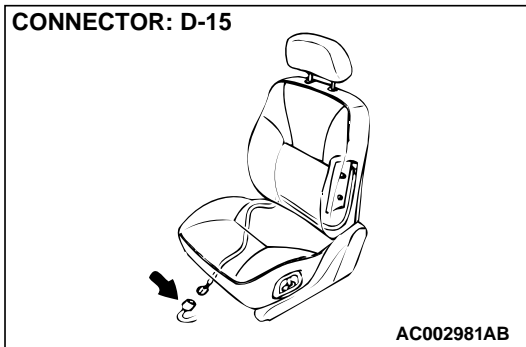
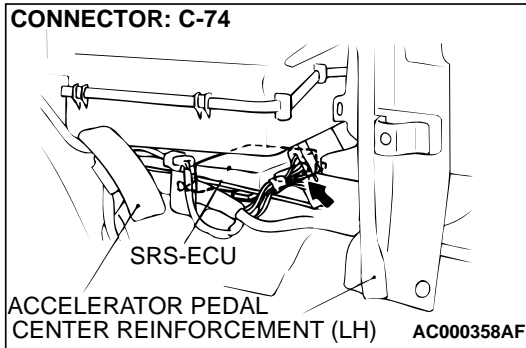

**STEP 2. Check the harness wires between SRS-ECU connector C-74 and side air bag module (LH) connector D-15.**

**Q: Are the harness wires between SRS-ECU connector C-74 and side air bag module (LH) connector D-15 in good condition?**

**YES :** Go to Step 3.

**NO :** Repair them. Then go to Step 3.

**STEP 3. Check for DTC.**

**Q: Is any of DTC 81, 82, 85 or 86 output?**

**YES :** Replace the SRS-ECU. Refer to [P.52B-66](#).

**NO :** This diagnosis is complete. (If no malfunctions are not found in all steps, an intermittent malfunction is suspected. Refer to GROUP 00, How to Use Troubleshooting/Inspection Service Points – How to Cope with Intermittent Malfunction [P.00-6](#).)

**DTC 89: Right hand side-air bag module (squib) system fault 5 for power supply circuit**  
**DTC 96: Right hand side-air bag module (squib) system fault 6 for communication system**

**Side Impact Sensor (RH) Circuit**

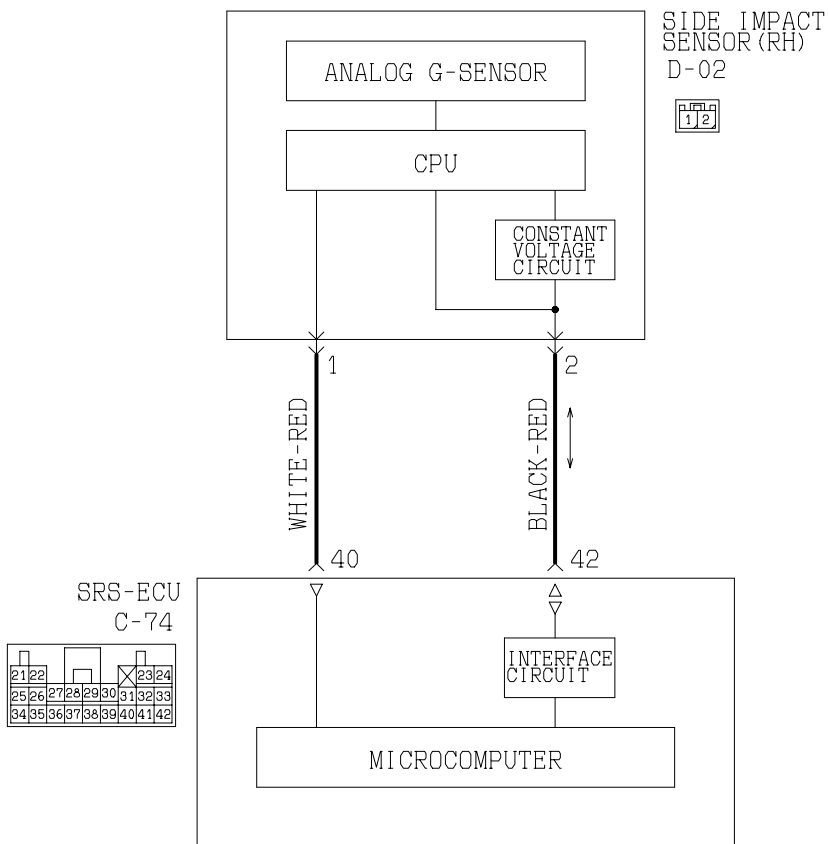

W1S01M02AA  
AC002965AB

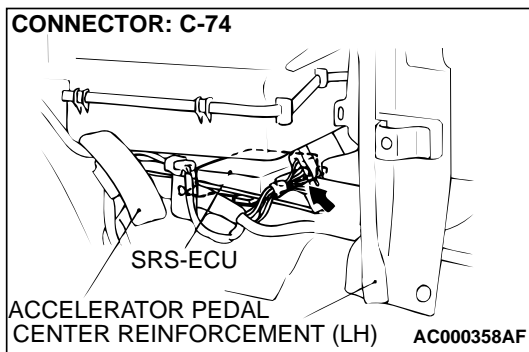

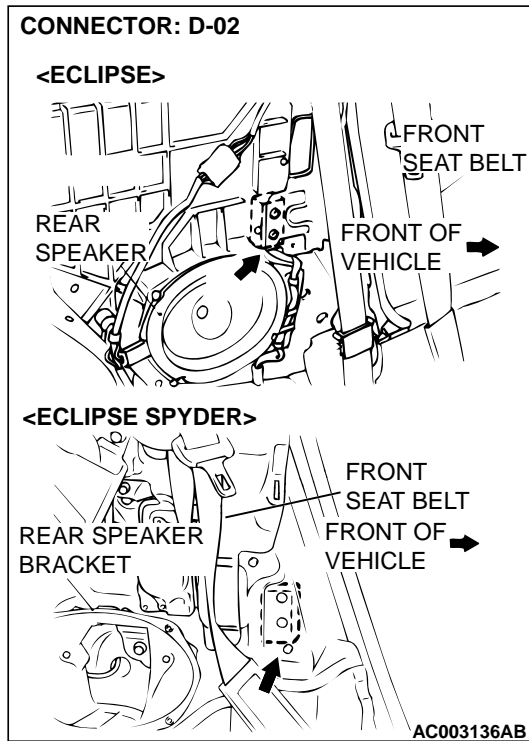

### CIRCUIT OPERATION

- The SRS-ECU judges how severe a by detecting signals from the left and right side impact sensors and the analog G-sensor. If the impact is over a predetermined level, the SRS-ECU outputs an ignition signal. At this time, if the safing G-sensor is on, the SRS air bag will inflate.

### DTC SET CONDITIONS

- These DTC are output if communication between the side impact sensor (RH) and the SRS-ECU is not possible or faulty.

### TROUBLESHOOTING HINTS

- Damaged wiring harnesses or connectors
- Malfunction of the side impact sensor (RH)
- Malfunction of the SRS-ECU

### DIAGNOSIS

#### Required Special Tool:

- MB991502: Scan Tool (MUT-II)

#### STEP 1. Check the side impact sensor

- (1) Replace the side impact sensor (RH) with the side impact sensor (LH)
- (2) Connect the negative battery terminal.
- (3) Erase DTC memory.

#### Q: Is any of DTC 89 or 96 erased or DTC 79 or 93 out put?

**YES** : Replace the side impact sensor (RH) with a new one.  
Refer to [P.52B-76](#). Go to Step 3.

**NO** : Go to Step 2.

**STEP 2. Check the harness wires between SRS-ECU connector C-74 and side impact sensor (RH) connector D-02.**

**Q: Are the harness wires between SRS-ECU connector C-74 and side impact sensor (RH) connector D-02?**

**YES :** Go to Step 3.

**NO :** Repair them. Then go to Step 3.

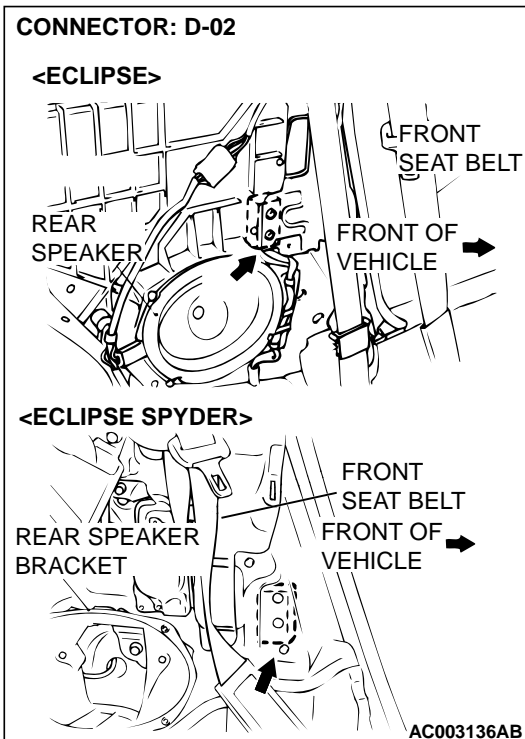
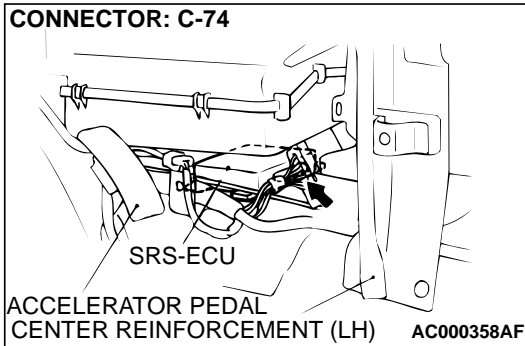

**STEP 3. Check for DTC.**

**Q: Is any of DTC 89 or 96 output?**

**YES :** Replace the SRS-ECU. Refer to [P.52B-66](#).

**NO :** This diagnosis is complete. (If no malfunctions are not found in all steps, an intermittent malfunction is suspected. Refer to GROUP 00, How to Use Troubleshooting/Inspection Service Points – How to Cope with Intermittent Malfunction [P.00-6](#).)

DTC 91: Left hand side-impact sensor power supply circuit system

Side Impact Sensor (LH) Power Supply Circuit

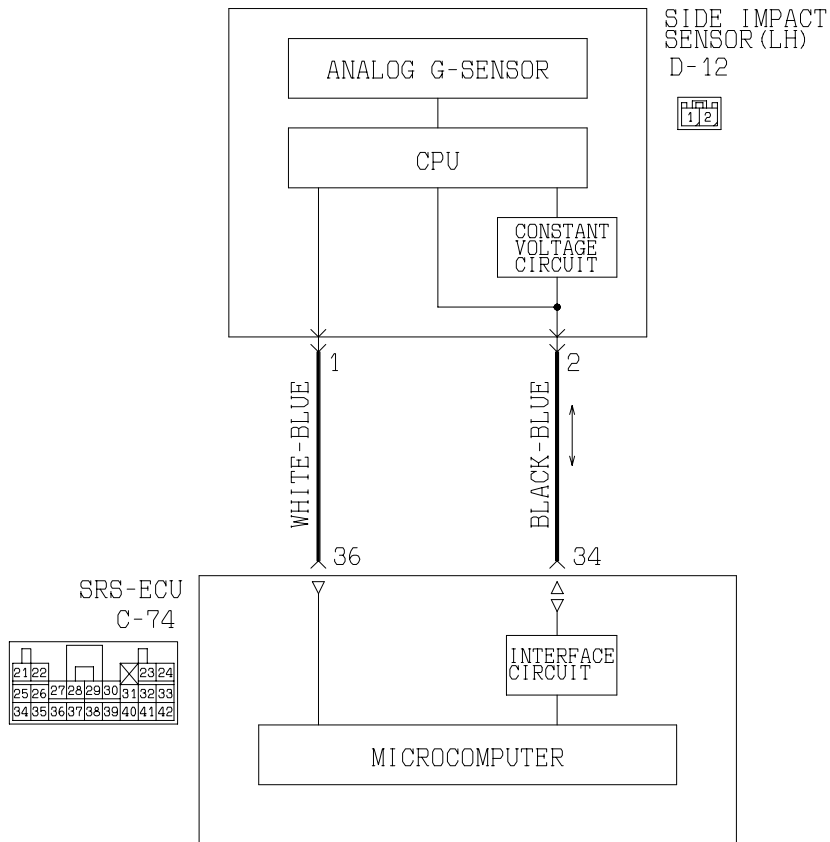

W1501M01AA  
AC003886AC

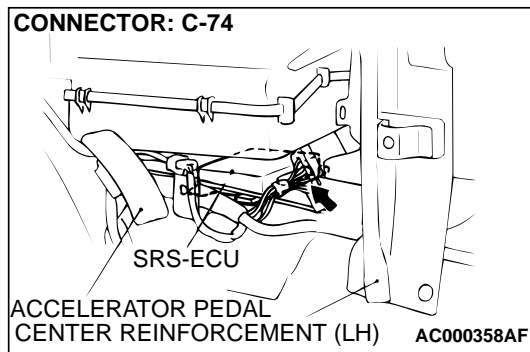



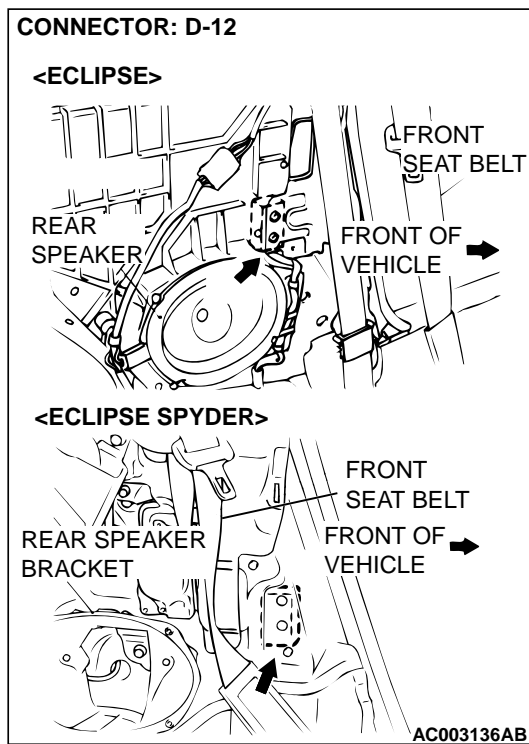

### CIRCUIT OPERATION

- The SRS-ECU judges how severe a collision is by detecting signals from the side impact sensor and the analog G-sensor. If the impact is over a predetermined level, the SRS-ECU outputs an ignition signal. At this time, if the safing G-sensor is on, the SRS air bag will inflate.

### DTC SET CONDITIONS

- This DTC is output if a poor connection at the SRS-ECU is detected. However, if the vehicle condition returns to normal, DTC number 34 will be automatically erased, and the SRS warning light will go out.

### TROUBLESHOOTING HINTS

- Damaged connectors
- Malfunction of the side air bag module (LH) (squib)
- Malfunction of the SRS-ECU

### DIAGNOSIS

#### Required Special Tools:

- MB991502: Scan Tool (MUT-II)

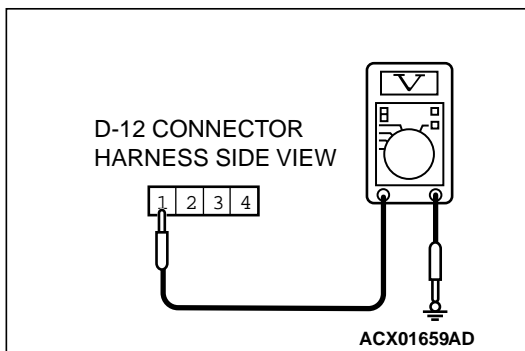
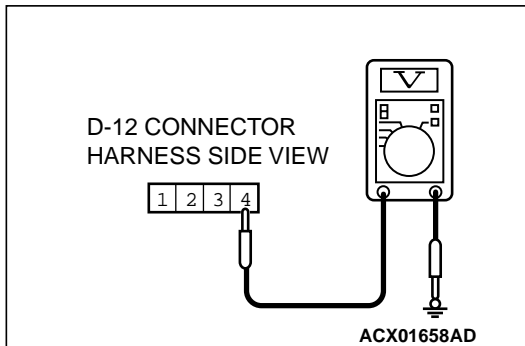

**STEP 1. Check the side impact sensor (LH) line at the SRS-ECU connector C-74 by backprobing.**

- (1) Do disconnect the side impact sensor (LH) connector D-12.
- (2) Connect the negative battery terminal.
- (3) Turn the ignition switch to "ON" position.
- (4) Measure the voltage between terminal 4 and the ground by backprobing.
  - Voltage should be 9 volts or more
- (5) Check the continuity between terminal 1 and the ground by backprobing.
  - Should be less than 2 ohm.

**Q: Does the voltage meet the specifications or is the resistance less than 2 ohm?**

**YES :** Replace the side impact sensor (LH). Refer to [P.52B-76](#). Then go to Step 3.

**NO :** Go to Step 2.

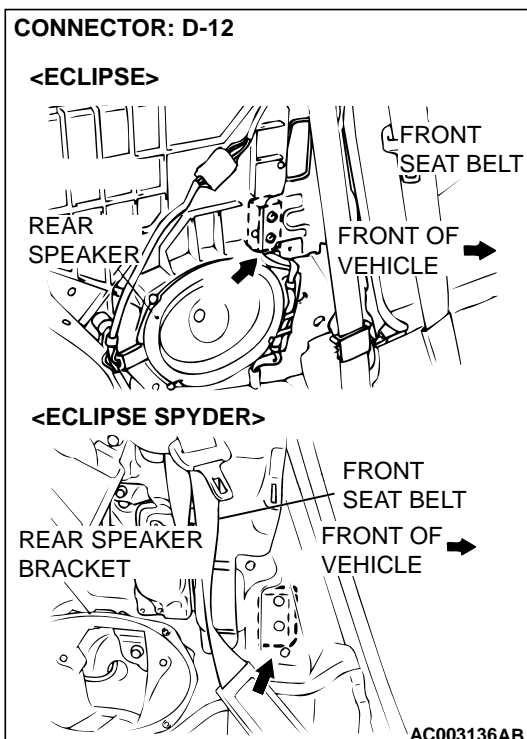
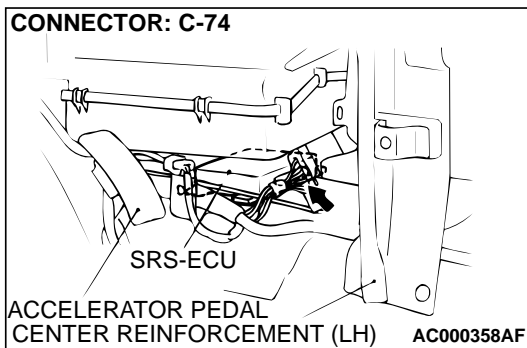

**STEP 2. Check the harness wires between SRS-ECU connector C-74 and side impact sensor (LH) connector D-12.**

**Q: Are the harness wires between SRS-ECU connector C-74 and side impact sensor (LH) connector D-12 in good condition?**

**YES :** Go to Step 3.

**NO :** Repair them. Then go to Step 3.

**STEP 3. Check DTC.**

**Q: Is DTC 91 output?**

**YES :** Replace the SRS-ECU. Refer to [P.52B-66](#).

**NO :** This diagnosis is complete. (If no malfunctions are not found in all steps, an intermittent malfunction is suspected. Refer to GROUP 00, How to Use Troubleshooting/Inspection Service Points – How to Cope with Intermittent Malfunction [P.00-6](#).)

**DTC 92: Left hand side-impact sensor system for fault 1**

**DTC 95: Right hand side-impact sensor system for fault 1**

**DTC SET CONDITIONS**

- This DTC is output if the following are detected

from the analog G-sensor output.

- Analog G-sensor is not operating.

- Analog G-sensor characteristics are abnormal.
- Analog G-sensor output is abnormal.

**TROUBLESHOOTING HINTS**

- Malfunction of side impact sensor <LH> (for DTC 92) and side impact sensor <RH> (for DTC 95)

**DIAGNOSIS**

Replace side impact sensor <LH> (for DTC 92) and side impact sensor <RH> (for DTC 95). Refer to P.52B-76.

**Q: Is any of DTC 92 or 95 output?**

**YES :** Replace the SRS-ECU. Refer to P.52B-66.

**NO :** This diagnosis is complete.(If no malfunctions are not found in all steps, an intermittent malfunction is suspected. Refer to GROUP 00, How to Use Troubleshooting/Inspection Service Points – How to Cope with Intermittent Malfunction P.00-6.)

**DTC 94: Right hand side-impact sensor power supply circuit system**

Side Impact Sensor (RH) Power Supply Circuit

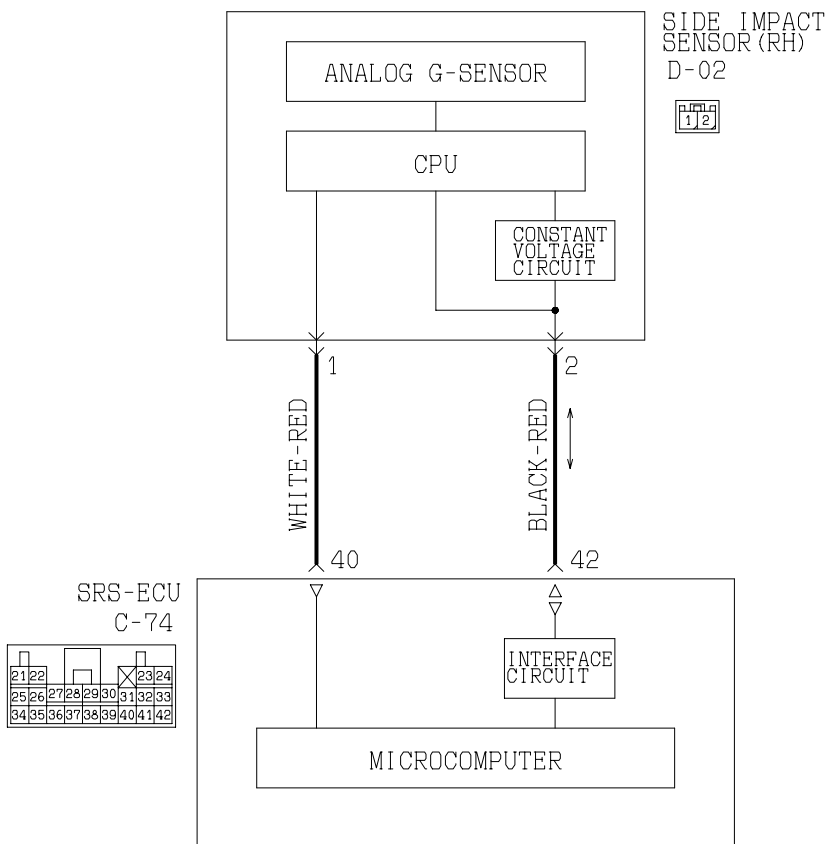

W1S01M02AA  
AC002965AC

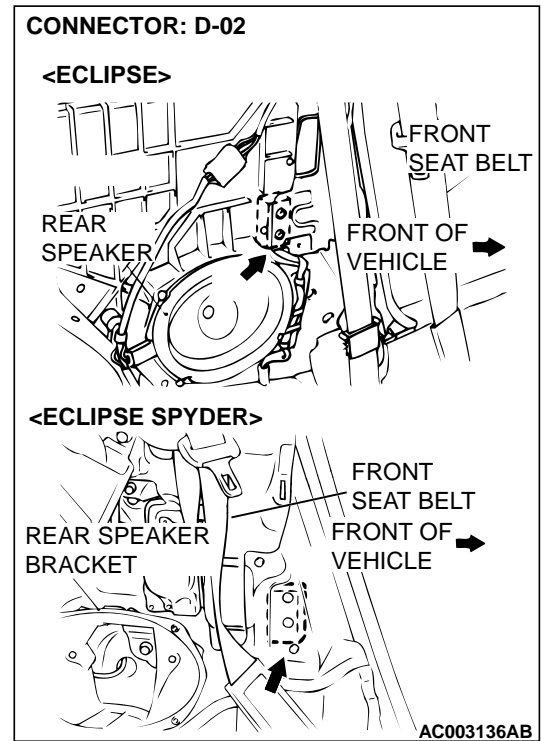
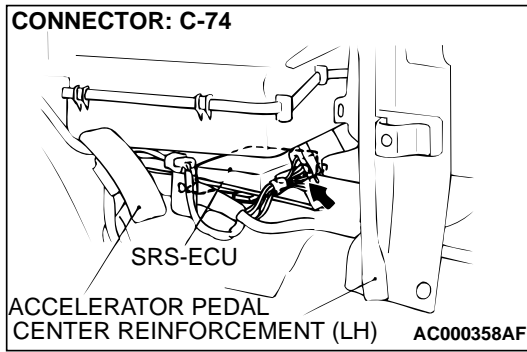

**CIRCUIT OPERATION**

- The SRS-ECU judges how severe a collision is by detecting signals from the side impact sensor and the analog G-sensor. If the impact is over a predetermined level, the SRS-ECU outputs an ignition signal. At this time, if the safing G-sensor is on, the SRS air bag will inflate.

**DTC SET CONDITIONS**

- This DTC is output if the power supply voltage of the side impact sensor (RH) drops below the rated value for a continuous period of 5 seconds or more. However, DTC number 94 will be automatically cleared and the SRS warning light will switch off if the condition returns to normal.

**TROUBLESHOOTING HINTS**

- Damaged wiring harnesses or connectors
- Malfunction of the side air bag module (RH) (squib)
- Malfunction of the SRS-ECU

**DIAGNOSIS**

**Required Special Tools:**

MB991502: Scan Tool (MUT-II)

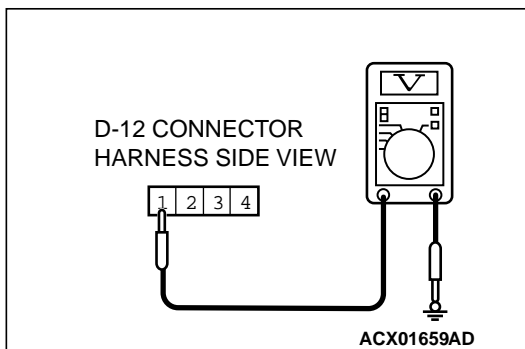
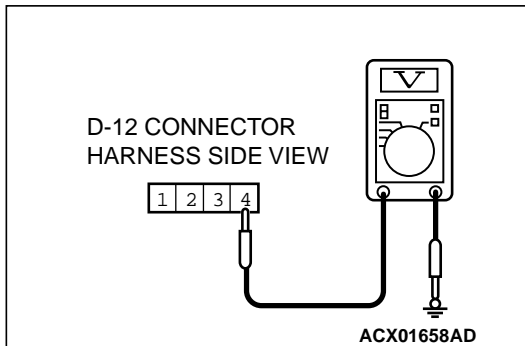

**STEP 1. Check the side impact sensor (RH) line at the SRS-ECU connector C-74 by backprobing.**

- (1) Do disconnect the side impact sensor (RH) connector D-02
- (2) Connect the negative battery terminal.
- (3) Turn the ignition switch to "ON" position.
- (4) Measure the voltage between terminal 4 and the ground by backprobing.
  - Voltage should be 9 volts or more.
- (5) Check the continuity between terminal 1 and the ground by backprobing.
  - Should be less than 2 ohm.

**Q: Does the voltage meet the specifications or is the resistance less than 2 ohm?**

**YES :** Replace the side impact sensor (LH). Refer to [P.52B-76](#). Then go to Step 3.

**NO :** Go to Step 2.

**STEP 2. Check the harness wires between SRS-ECU connector C-74 and side impact sensor (RH) connector D-02.**

**Q: Are the harness wires between SRS-ECU connector C-74 and side impact sensor (RH) connector D-02 in good condition?**

**YES :** Go to Step 3.

**NO :** Repair them. Then go to Step 3.

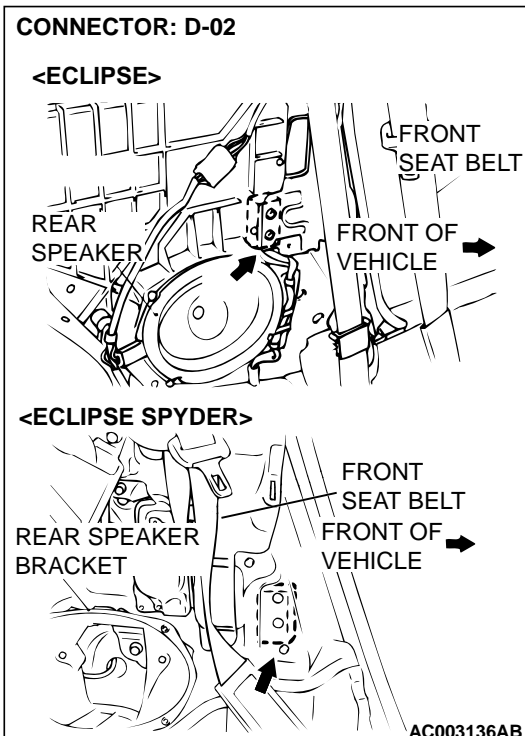
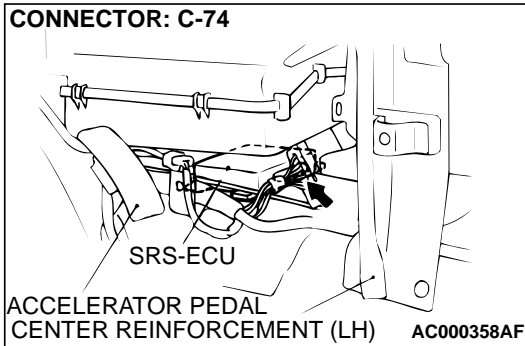

**STEP 3. Check for DTC.**

**Q: Is DTC 94 output?**

**YES :** Replace the SRS-ECU. Refer to [P.52B-66](#).

**NO :** This diagnosis is complete. (If no malfunctions are not found in all steps, an intermittent malfunction is suspected. Refer to GROUP 00, How to Use Troubleshooting/Inspection Service Points – How to Cope with Intermittent Malfunction [P.00-6](#).)

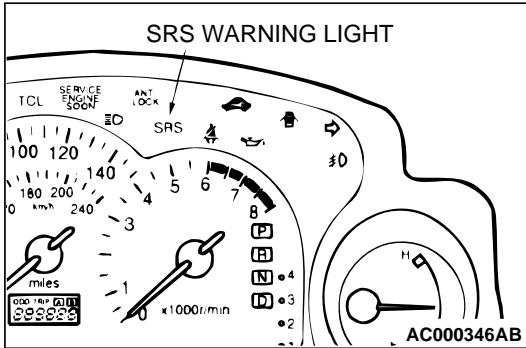
**SRS WARNING LIGHT CHECK**

1. Check that the SRS warning light illuminates when the ignition switch is in the "ON" position.
2. Check that it illuminates for approximately 7 seconds and then goes out.
3. If not, check for DTC.



SYMPTOM PROCEDURES

M1524010300047

**INSPECTION PROCEDURE 1: Communication with scan tool MB991502 is not possible with the SRS system only.**

SRS-ECU Power Supply Circuit

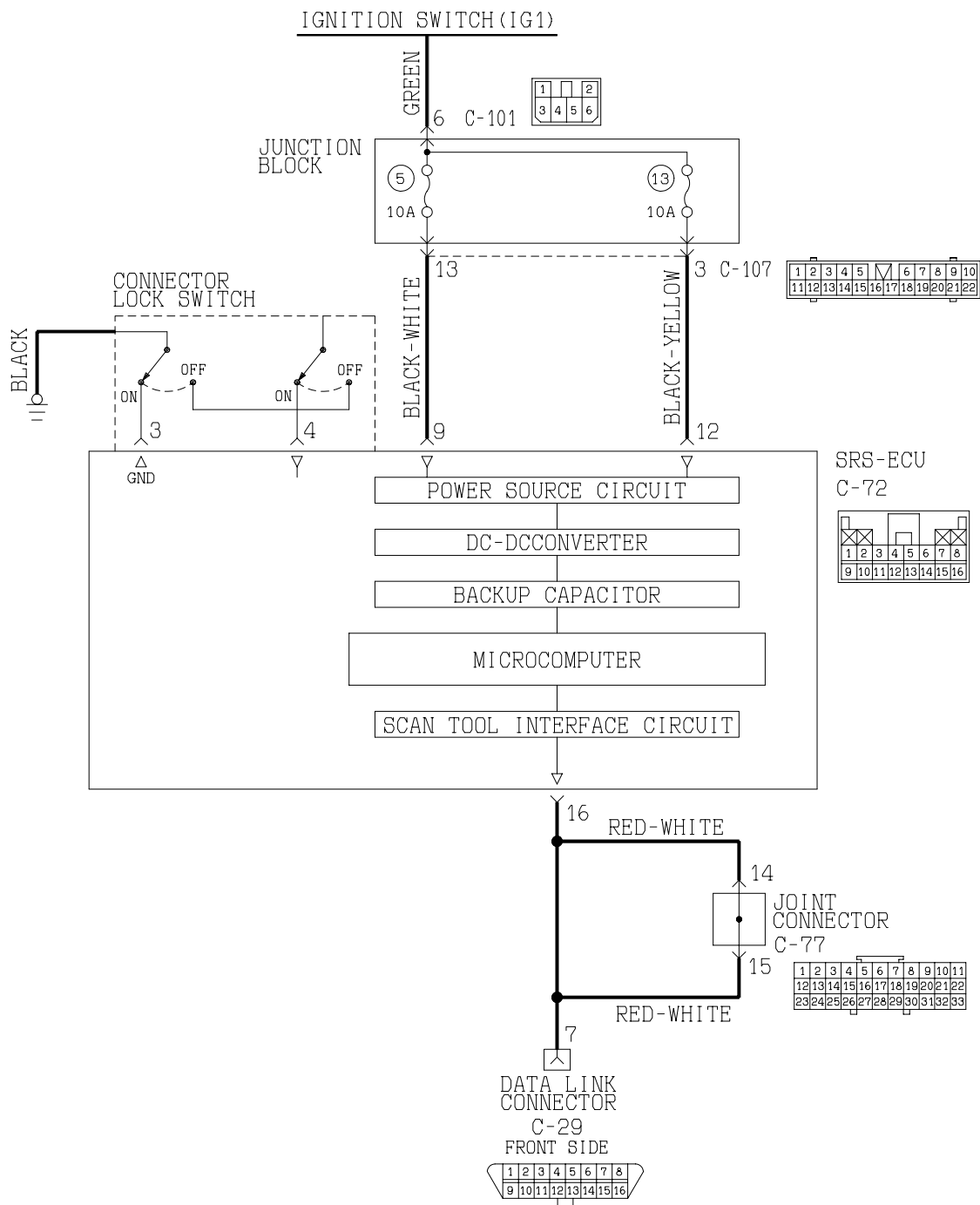

W1501M03AA  
AC002969AB

TSB Revision

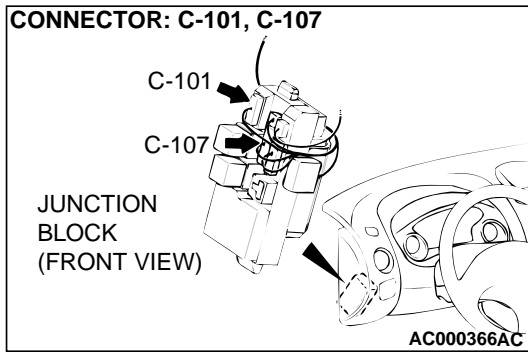
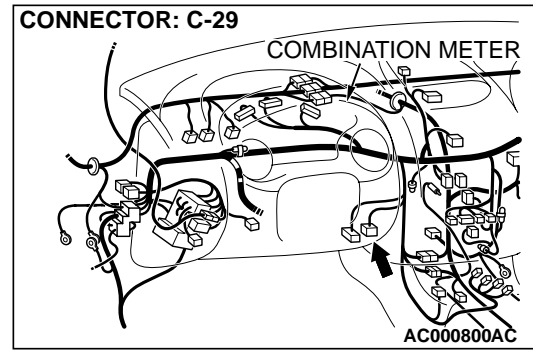
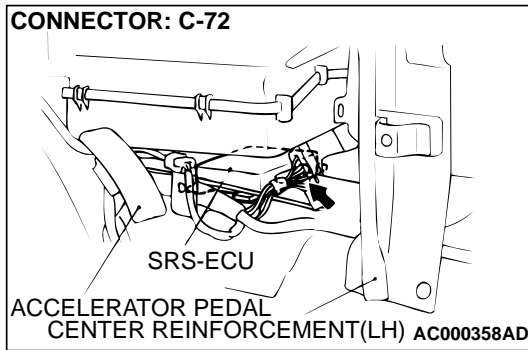

**CIRCUIT OPERATION**

- The SRS-ECU is powered from the ignition switch (IG1).
- The SRS-ECU power is supplied from two circuits. Even if one circuit is shut off, the air bag can inflate.
- The SRS system diagnosis can be done by connecting scan tool MB991502 to the data link connector.

- The SRS-ECU judges how severe a collision is by detecting signals from the left and right side impact sensors and the analog G-sensor. If the impact is over a predetermined level, the SRS-ECU outputs an ignition signal. At this time, if the safing G-sensor is on, the SRS air bag will inflate.

**TECHNICAL DESCRIPTION (COMMENT)**

- If communication is not possible with the SRS only, the cause is probably an open circuit in the on-board diagnostic output circuit of the SRS or in the power circuit (including ground circuit).

**TROUBLESHOOTING HINTS**

- Damaged wiring harnesses or connectors
- Malfunction of the SRS-ECU

**DIAGNOSIS**

**STEP 1. Check the ground line at the SRS-ECU connector C-72 by backprobing.**

- (1) Do disconnect the connector C-72.
- (2) Check the continuity between terminal 3 and the ground by backprobing.

**Q: Is the resistance between terminal 3 and ground less than 2 ohm?**

- YES :** Go to Step 3.  
**NO :** Go to Step 2.

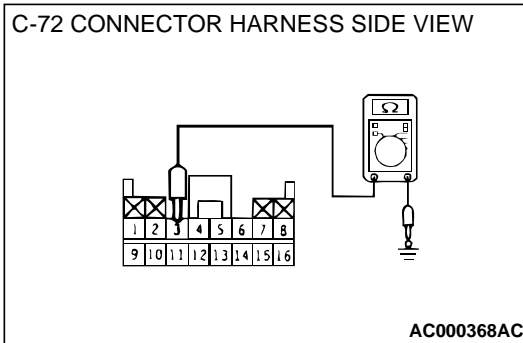

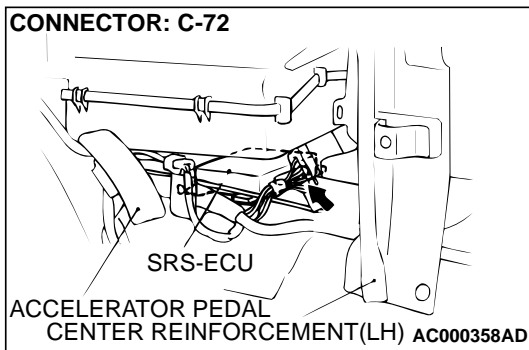

**STEP 2. Check the harness wires between SRS-ECU connector C-72 and ground.**

**Q: Is the harness wires between SRS-ECU connector C-72 and ground in good condition?**

**YES :** Go to Step 5.

**NO :** Repair them. Then go to Step 5.

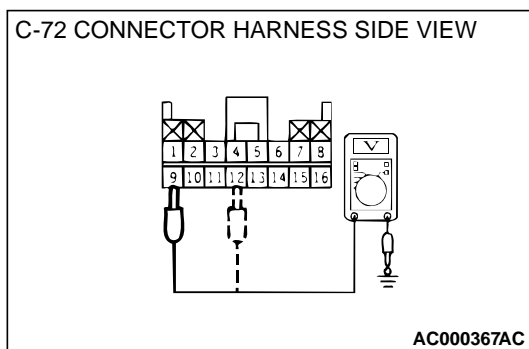

**STEP 3. Check the ignition switch (IG1) line at the SRS-ECU connector C-72 by backprobing.**

(1) Do disconnect the connector C-72.

(2) Turn the ignition switch to "ON" position.

(3) Measure the voltage between terminal 9 and the ground.

- Voltage should be 9 volts or more

(4) Measure the voltage between terminal 12 and the ground by backprobing.

- Voltage should be 9 volts or more

**Q: Is the voltage between terminal 9,12 and the ground 9 V or more?**

**YES :** Go to Step 5.

**NO :** Go to Step 4.

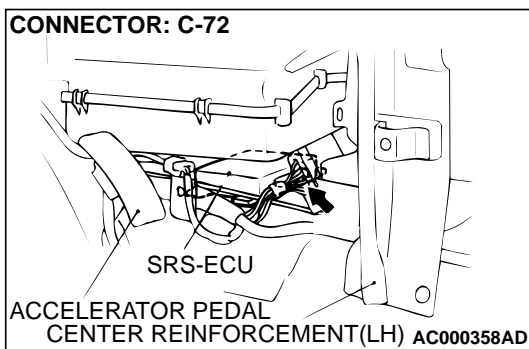

**STEP 4. Check the harness wires between ignition switch (IG1) and SRS-ECU connector C-72.**

*NOTE: After inspecting intermediate connectors C-101, C-107 inspect the wiring harness. If intermediate connectors C-101, C-107 are damaged, repair or replace them. Refer to GROUP 00E, Harness Connector Inspection P.00E-2. Then go to Step 6.*

**Q: Are the harness wires between ignition switch (IG1) and SRS-ECU connector C-72 in good condition?**

**YES :** Go to Step 6.

**NO :** Repair them. Then go to Step 6.

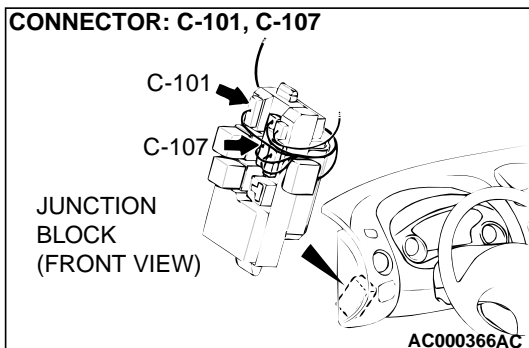

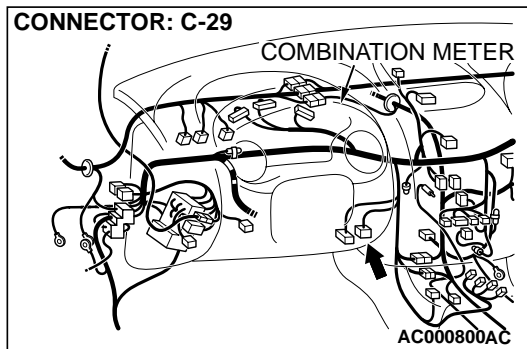
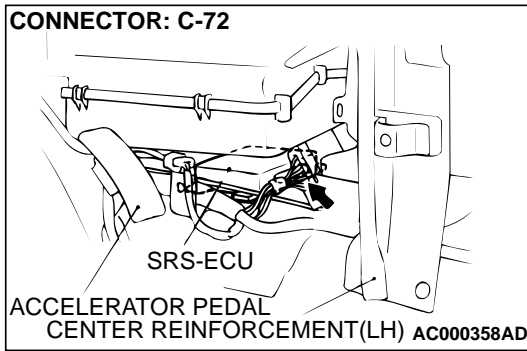

**STEP 5. Check the harness wires between SRS-ECU connector C-72 and data link connector C-29.**

**Q: Are the harness wires between SRS-ECU connector C-72 and data link connector C-29 in good condition?**

**YES :** Replace the SRS-ECU. Refer to [P.52B-66](#). Then go to Step 6.

**NO :** Repair them. Then go to Step 6.

**STEP 6. Check symptoms.**







**Q: Does the scan tool communicate normally with the SRS system?**

**YES :** This diagnosis is complete.(If no malfunctions are not found in all steps, an intermittent malfunction is suspected. Refer to GROUP 00, How to Use Troubleshooting/Inspection Service Points – How to Cope with Intermittent Malfunction [P.00-6](#).)

**NO :** There is no action to be taken

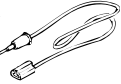
## SPECIAL TOOLS

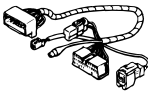
M1524000700077

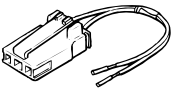
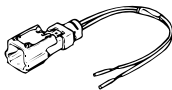
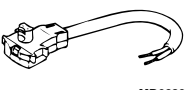
<b>TOOL</b>	<b>TOOL NUMBER AND NAME</b>	<b>REPLACED BY MILLER TOOL NUMBER</b>	<b>APPLICATION</b>
	MB991502 Scan tool (MUT-II)	MB991496-OD	<ul style="list-style-type: none"> <li>• Reading diagnostic trouble codes</li> <li>• Erasing diagnostic trouble codes</li> <li>• Reading vehicle data for a specific period</li> <li>• Reading erase times (Refer to MUT-II operating instructions)</li> </ul>
<p>A</p>  <p>B</p>  <p>C</p>  <p>D</p>  <p>MB991223AG</p>	MB991223 A: MB991219 B: MB991220 C: MB991221 D: MB991222 Harness set A: Test harness B: LED harness C: LED harness adapter D: Probe	-	Checking the continuity and measuring the voltage at the SRS-ECU harness connector
	MB991613 SRS check harness	MB991613	Checking the SRS electrical circuitry with a digital multi-meter
	MB990803 Steering wheel puller	General service tool	Removal of steering wheel
	MR372530 SRS air bag adapter harness A	General service tool	Deployment of air bag module (Driver's side) inside the vehicle
	MB686560 SRS air bag adapter harness B	General service tool	<ul style="list-style-type: none"> <li>• Deployment of air bag module (Front passenger's side) inside the vehicle</li> <li>• Deployment of air bag module (Front passenger's side) outside the vehicle</li> </ul>
	MR203491 or MB628919 SRS air bag adapter harness C	General service tool	Deployment of air bag module (Driver's side) outside the vehicle

## TEST EQUIPMENT

M1524000800074

TOOL	NAME	USE
 AC000019AB	Digital multi-meter Use a multi-meter for which the maximum test current is 2 mA or less at the minimum range of resistance measurement	Checking the SRS electrical circuitry with SRS check harness

## SRS MAINTENANCE

M1524003900070

The SRS must be inspected by an authorized dealer up to 10 years after the date of vehicle registration. (Refer to GROUP 00, Maintenance Service – SRS Maintenance [P.00-55](#).)

## POST-COLLISION DIAGNOSIS

M1524001100078

To inspect and service the SRS after a collision (whether or not the air bags have deployed), perform the following steps.

## SRS-ECU MEMORY CHECK

## Required Special Tool:

- MB991502: Scan tool (MUT-II)

**CAUTION**

To prevent damage to scan tool MB991502, always turn the ignition switch to "LOCK" (OFF) position before connecting or disconnecting scan tool MB991502.

1. Connect scan tool MB991502 to the data link connector (16-pin).

*NOTE: If the battery power supply has been disconnected or disrupted by the collision, scan tool MB991502 cannot communicate with the SRS-ECU. Check the battery then check and, if necessary, repair the front wiring harness and the body wiring harness before proceeding.*

2. Read (and write down) all displayed DTC. (Refer to [P.52B-18](#).)
3. Read the data list (fault duration and how many times memories are erased) using scan tool MB991502.

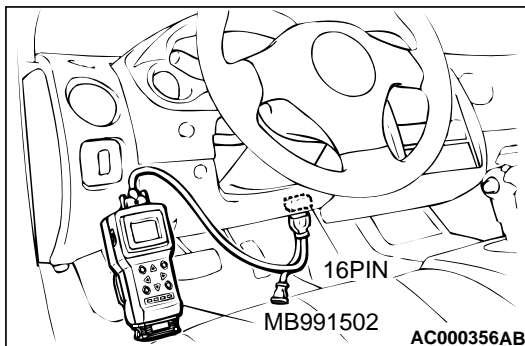

**Data list**

<b>NO.</b>	<b>SERVICE DATA ITEM</b>	<b>APPLICABILITY</b>
92	Number indicating how often the memory is cleared	Maximum time to be stored: 250
93	How long a problem has lasted (How long it takes from the occurrence of the problem till the first air bag squib igniting signal)	Maximum time to be stored: 9,999 minutes (approximately 7 days)
94	How long a problem has lasted (How long it takes from the first air bag squib igniting signal till now.)	

4. Erase the DTC and, after waiting 5 seconds or more, read (and write down) all displayed DTC. (Refer to [P.52B-18.](#))

**REPAIR PROCEDURE**

**WHEN FRONT AIR BAGS DEPLOY IN A COLLISION.**

1. Replace the following parts with new ones.
  - SRS-ECU (Refer to [P.52B-66.](#))
  - Air bag module (Refer to [P.52B-69.](#))
2. Check the following parts and replace if there are any malfunctions.
  - Clock spring (Refer to [P.52B-69.](#))
  - Steering wheel, steering column and intermediate joint
    - (1) Check the wiring harness (built into the steering wheel) and connectors for damage, and terminals for deformation.
    - (2) Install the air bag module to check fit or alignment with the steering wheel.
    - (3) Check the steering wheel for noise, binds or difficult operation and excessive free play.
3. Check the wiring harnesses for binding, the connectors for damage, poor connections, and the terminals for deformation. (Refer to [P.52B-15.](#))

**WHEN SIDE AIR BAG DEPLOYS IN A COLLISION.**

1. Replace the following parts with new ones.
  - SRS-ECU (Refer to [P.52B-66.](#))
  - Side impact sensors (Refer to [P.52B-76.](#))
  - Front seat back assembly (Refer to GROUP 52A, Front seat [P.52A-18.](#))
2. Check the wiring harnesses for binding, the connectors for damage, poor connections, and the terminals for deformation. (Refer to [P.52B-15.](#))

**WHEN AIR BAG DOES NOT DEPLOY IN LOW-SPEED COLLISION.**

Check the SRS components. If the SRS components are showing any visible damage such as dents, cracks, or deformation, replace them with new ones. Concerning parts removed for inspection, replacement with new parts and cautionary points for working, refer to appropriate INDIVIDUAL COMPONENT SERVICE, [P.52B-66](#).

**SRS-ECU**

1. Check the SRS-ECU case and brackets for dents, cracks or deformation.
2. Check the connector for damage, and the terminals for deformation.

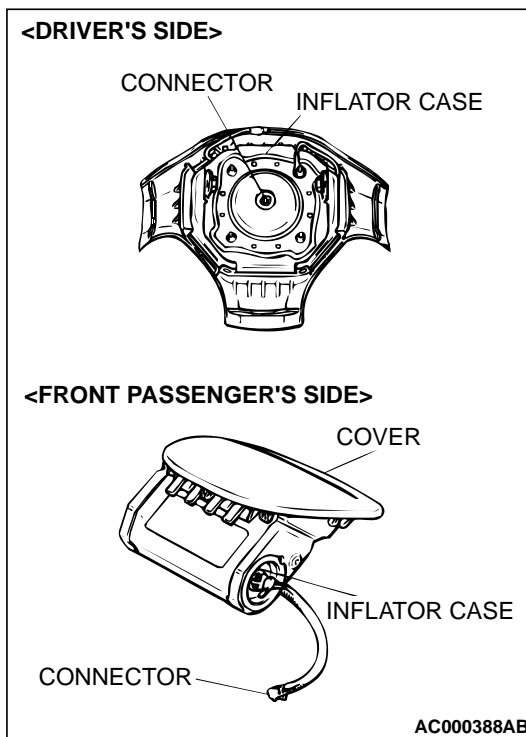
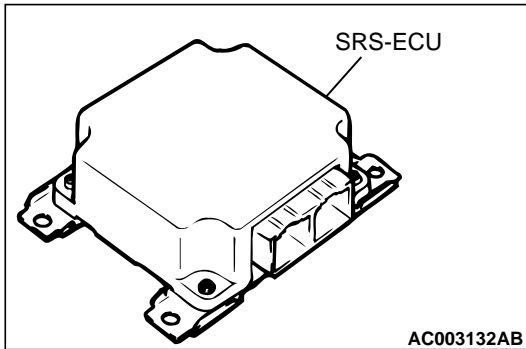
**Air bag modules**

1. Check the pad cover for dents, cracks or deformation.
2. Check the connector for damage, terminals deformities, and the harness for binding.
3. Check the air bag inflator case for dents, cracks or deformities.
4. Install the air bag module (driver's side) to the steering wheel to check fit or alignment with the steering wheel.
5. Install the air bag module (front passenger's side) to the instrument panel and crossmember to check fit or alignment.
6. Install the air bag module cover (front passenger's side) to the instrument panel to check fit or alignment.





**Front seat back assembly (Side air bag module)**

1. Check that there is no abnormality in the seat air bag module deployment section.
2. Check that there is no connector damage, bent terminals or clamping of the harness.

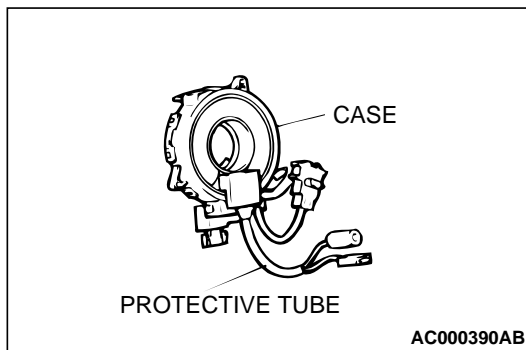

**Clock spring**

1. Check the clock spring connectors and protective tube for damage, and the terminals for deformation.
2. Visually check the case for damage.

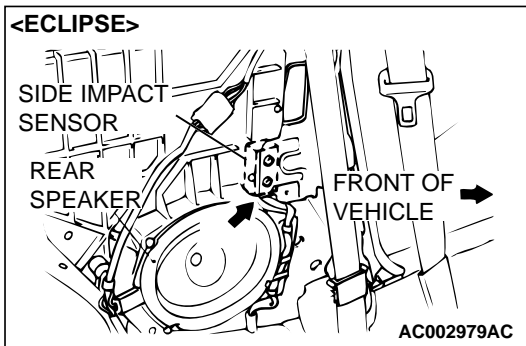

**Side impact sensor**

1. Check that there is no bending or corrosion in the center pillar.
2. Check that there is no denting, breakage or bending of the side impact sensor.
3. Check that there is no clamping of the harness, connector damage or bent terminals.

*NOTE: The illustration at left shows the side impact sensor (LH). The position of the side impact sensor (RH) is symmetrical to this.*

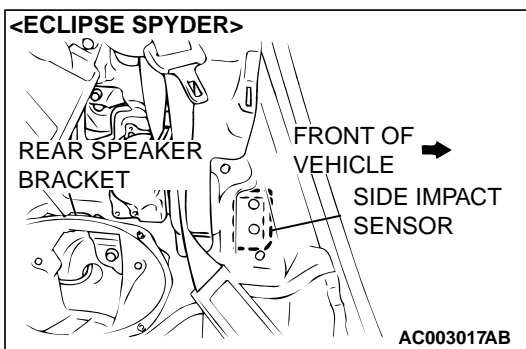

**Steering wheel, steering column and intermediate joint**

1. Check the wiring harness (built into the steering wheel) and the connectors for damage, and the terminals for deformation.
2. Install the air bag module to check fit or alignment with the steering wheel.
3. Check the steering wheel for noise, binding or difficult operation and excessive free play.

**Harness connector (floor wiring harness)**

Check the harnesses for binding, the connectors for damage, poor connection, and the terminals for deformation. (Refer to [P.52B-15.](#))

## INDIVIDUAL COMPONENT SERVICE

M1524002900077

**⚠ WARNING**

- ***The SRS components should not be subjected to heat over 93°X (200°F), so remove the SRS-ECU, air bag modules (driver's side and front passenger's side), front seat assemblies (side air back module), clock spring, side impact sensors before drying or baking the vehicle after painting. Recheck the SRS system operability after reinstalling them. (Refer to GROUP 00, Maintenance Service -SRS Maintenance [P.00-55.](#))***
- ***If the SRS components are removed for the purpose of checking, sheet metal repair, painting, etc., they should be stored in a clean, dry place until they are reinstalled.***

If the SRS components are to be removed or replaced as a result of maintenance, diagnosis, etc., follow the appropriate procedure in this section. (SRS Air Bag Control Unit: refer to [P.52B-66](#), Air Bag Modules and Clock Spring: refer to [P.52B-69](#), Side impact sensor: refer to [P.52B-76.](#))

## SRS CONTROL UNIT (SRS-ECU)

M1524002100071

**⚠ WARNING**

- ***Never attempt to disassemble or repair the SRS-ECU. If faulty, replace it.***
- ***Do not drop or subject the SRS-ECU to impact or vibration. If denting, cracking, deformation, or rust are discovered in the SRS-ECU, replace it with a new SRS-ECU. Discard the old one.***
- ***After deployment of an air bag, replace the SRS-ECU with a new one.***
- ***Never use an ohmmeter on or near the SRS-ECU, and use only the special test equipment described on [P.52B-62.](#)***

REMOVAL AND INSTALLATION

<p><b>Pre-removal Operation</b></p> <ul style="list-style-type: none"> <li>• Turn the ignition switch to "LOCK" (OFF) position.</li> <li>• Floor Console Removal (Refer to GROUP 52A, Floor Console P.52A-9.)</li> </ul>	<p><b>Post-installation Operation</b></p> <ul style="list-style-type: none"> <li>• Floor Console Installation (Refer to GROUP 52A, Floor Console P.52A-9.)</li> </ul>
--	---

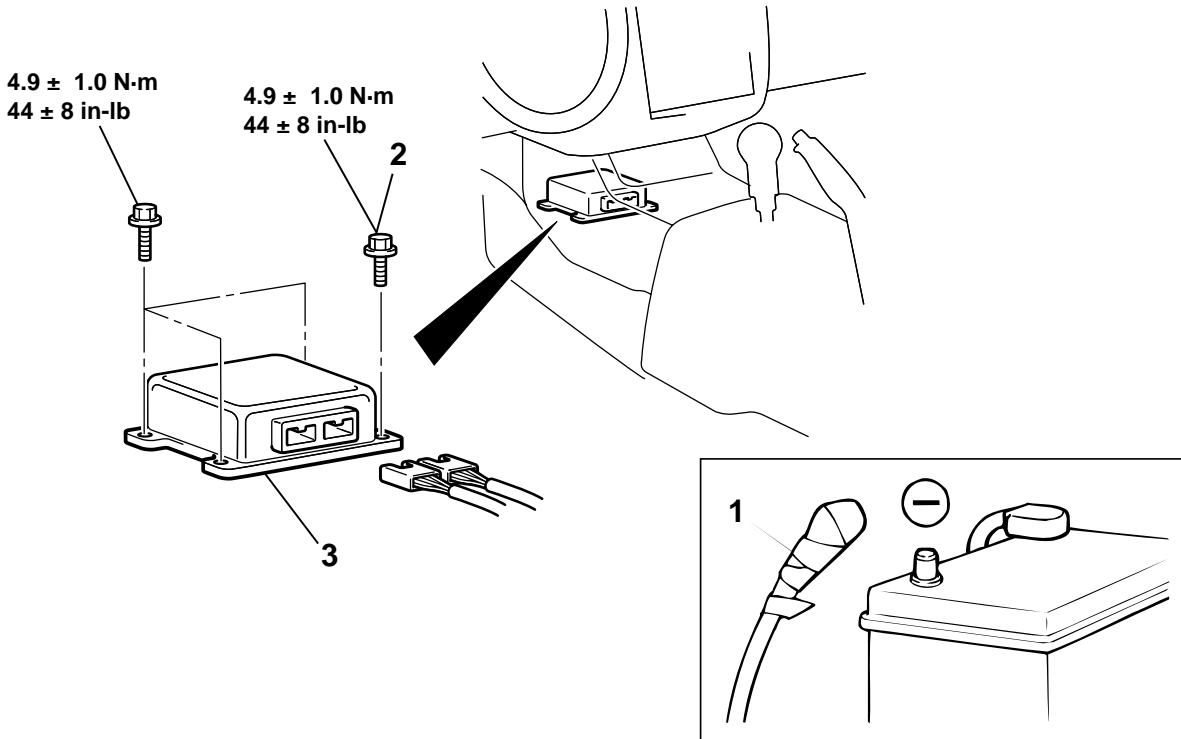

AC003160AB

- <<A>>
- REMOVAL STEPS**
1. NEGATIVE (-) BATTERY CABLE CONNECTION
  2. BRACKET MOUNTING BOLT (GROUNDING BOLT)
  3. SRS-ECU

- >>A<<
- >>B<<
- >>C<<
- INSTALLATION STEPS**
3. SRS-ECU
  2. BRACKET MOUNTING BOLT (GROUNDING BOLT)
  1. NEGATIVE (-) BATTERY CABLE CONNECTION
- POST-INSTALLATION INSPECTION

REMOVAL SERVICE POINT

<<A>> NEGATIVE (-) BATTERY CABLE DISCONNECTION

**⚠ DANGER**

*Wait at least 60 seconds after disconnecting the battery cable before doing any further work. (Refer to P.52B-15.)*

**⚠ WARNING**

*Battery posts, terminals and related accessories contain lead and lead compounds. WASH HANDS AFTER HANDLING.*

Disconnect the negative battery cable from the battery and tape the terminal to prevent accidental connection and deployment.

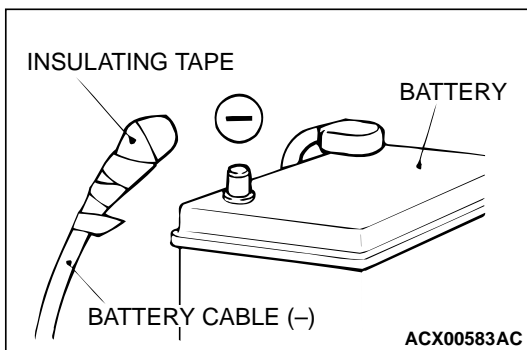

ACX00583AC

## INSTALLATION SERVICE POINTS

## &gt;&gt;A&lt;&lt; SRS-ECU INSTALLATION

**⚠ WARNING**

**The SRS may not activate if the SRS-ECU is not installed properly, which could result in serious injury or death to the vehicle's driver or front passenger.**

## &gt;&gt;B&lt;&lt; BRACKET MOUNTING BOLT (GROUNDING BOLT) INSTALLATION

Check the head mark "E" on the bolt and attach the grounding bolt.

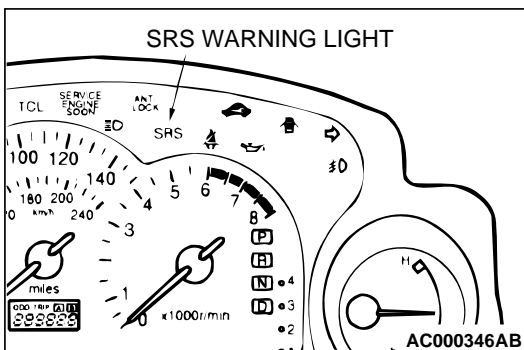
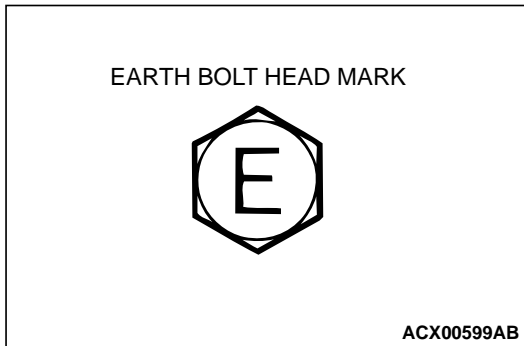

## &gt;&gt;C&lt;&lt; POST-INSTALLATION INSPECTION

1. Reconnect the negative (-) battery cable.
2. Turn the ignition switch to "ON" position.
3. Does the "SRS" warning light illuminate for approximately 7 seconds, and then remain off for at least 5 seconds after turning "OFF."
4. If yes, the SRS system is functioning properly. If no, refer to [P.52B-56](#).

## INSPECTION

M1524002200067

**⚠ WARNING**

**If a dent, crack, deformation or rust is discovered, replace the SRS-ECU with a new one.**

- Check the SRS-ECU and brackets for dents, cracks or deformation.
- Check the SRS-ECU connector for damage, and the terminals for deformation.

**NOTE:** Refer to [P.52B-20](#) for inspection of SRS-ECU for other than physical damage.

## AIR BAG MODULE(S) AND CLOCK SPRING

### AIR BAG MODULE(S) AND CLOCK SPRING REMOVAL AND INSTALLATION

M1524002400072

**⚠ WARNING**

- *Never attempt to disassemble or repair the air bag modules or clock spring. If faulty, replace it.*
- *Do not drop the air bag modules or clock spring or allow contact with water, grease or oil. Replace it if a dent, crack, deformation or rust is detected.*
- *The air bag modules should be stored on a flat surface is facing upward. Do not place anything on top of it.*
- *Do not expose the air bag modules to temperatures over 93°C (200°F).*
- *After deployment of an air bag, replace the clock spring with a new one.*
- *Wear gloves and safety glasses when handling air bags that have already deployed.*
- *An undeployed air bag module should only be disposed of in accordance with the procedures. (Refer to P.52B-80.)*

#### <Side air bag module>

For removal and installation of the front seatback assembly with side air bag module, refer to GROUP 52A, Front Seat P.52A-18.

### REMOVAL AND INSTALLATION

#### <Air bag module (driver's side), clock spring>

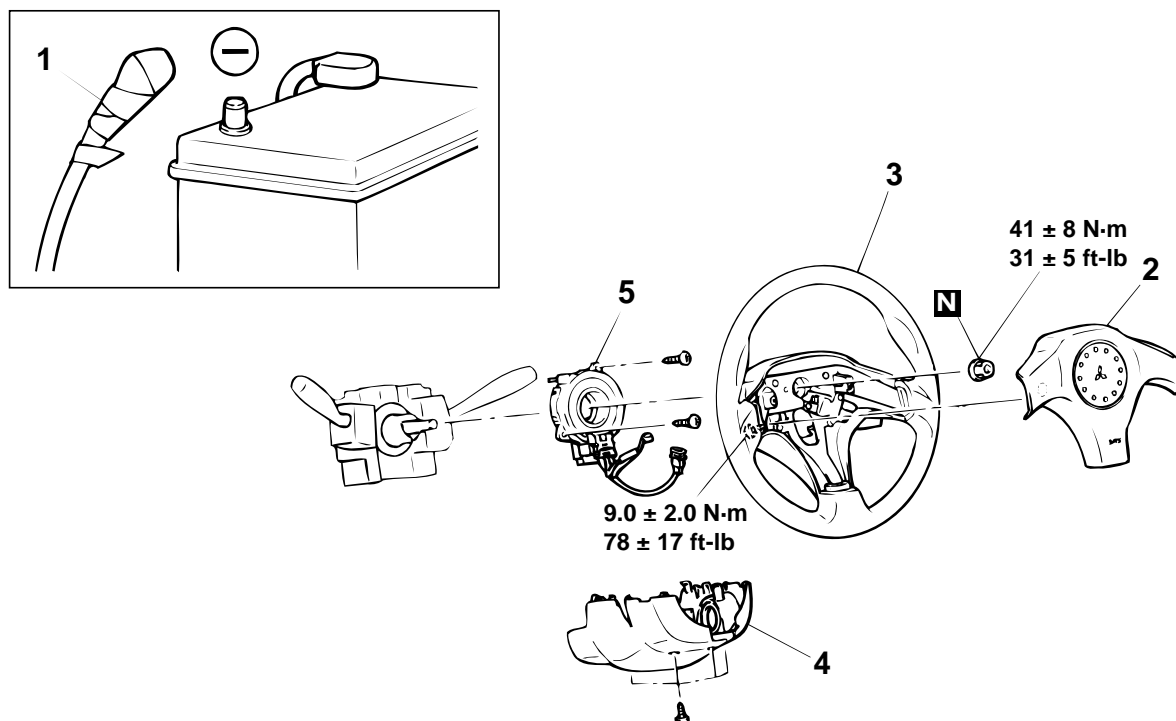

AC002990AB

#### AIR BAG MODULE REMOVAL STEPS

<<A>>

1. NEGATIVE (-) BATTERY CABLE CONNECTION

<<A>>

<<B>>

2. AIR BAG MODULE (DRIVER'S SIDE)

<<B>>

<<C>>

#### CLOCK SPRING REMOVAL STEPS

1. NEGATIVE (-) BATTERY CABLE CONNECTION
2. AIR BAG MODULE (DRIVER'S SIDE)
3. STEERING WHEEL

TSB Revision

- <<D>>
- CLOCK SPRING REMOVAL STEPS**
4. COLUMN COVER LOWER
  5. CLOCK SPRING
- AIR BAG MODULE INSTALLATION STEPS**
- >>A<<
- PRE-INSTALLATION INSPECTION
- >>D<<
2. AIR BAG MODULE (DRIVER'S SIDE)
  1. NEGATIVE (-) BATTERY CABLE CONNECTION
- >>E<<
- POST-INSTALLATION INSPECTION
- CLOCK SPRING INSTALLATION STEPS**
- >>A<<
- PRE-INSTALLATION INSPECTION
- >>B<<
5. CLOCK SPRING
  4. COLUMN COVER LOWER

- CLOCK SPRING INSTALLATION STEPS (Continued)**
- >>C<<
3. STEERING WHEEL
- >>D<<
2. AIR BAG MODULE (DRIVER'S SIDE)
  1. NEGATIVE (-) BATTERY CABLE CONNECTION
- >>E<<
- POST-INSTALLATION INSPECTION

- Required Special Tools:**
- MB990502: Scan Tool (MUT-II)
  - MB990803: Steering Wheel Puller
  - MB991613: SRS Check Harness

(front passenger's side)>

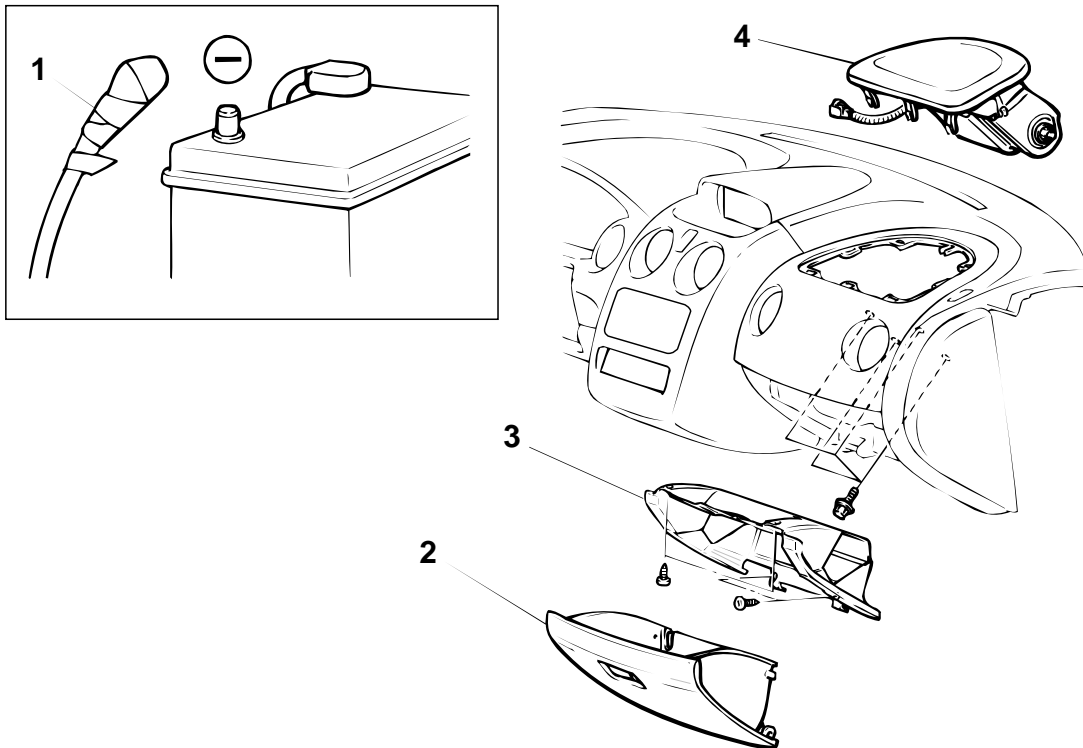

AC000698AB

- <<A>>
- AIR BAG MODULE REMOVAL STEPS**
1. NEGATIVE (-) BATTERY CABLE CONNECTION
  2. GLOVE BOX OUTER
  3. GLOVE BOX INNER
  4. AIR BAG MODULE (FRONT PASSENGER'S SIDE)
- <<E>>

- AIR BAG MODULE INSTALLATION STEPS**
- >>A<<
- PRE-INSTALLATION INSPECTION
- >>E<<
4. AIR BAG MODULE (FRONT PASSENGER'S SIDE)
  3. GLOVE BOX INNER
  2. GLOVE BOX OUTER
  1. NEGATIVE (-) BATTERY CABLE CONNECTION
- >>E<<
- POST-INSTALLATION INSPECTION

**Required Special Tools:**

- MB990502: Scan Tool (MUT-II)
- MB990803: Steering Wheel Puller
- MB991613: SRS Check Harness

**REMOVAL SERVICE POINT**

**<<A>> NEGATIVE (-) BATTERY CABLE DISCONNECTION**

**⚠ DANGER**

*Wait at least 60 seconds after disconnecting the battery cable before doing any further work. (Refer to P.52B-15.)*

**⚠ WARNING**

*Battery posts, terminals and related accessories contain lead and lead compounds. WASH HANDS AFTER HANDLING.*

Disconnect the negative (-) battery cable from the battery and tape the terminal to prevent accidental connection and air bag(s) deployment.

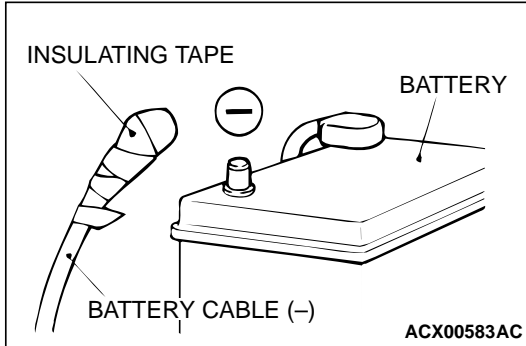

**<<B>> AIR BAG MODULE REMOVAL (DRIVER'S SIDE)**

1. Remove the air bag module mounting screws (TORX® screws) at the sides of the steering wheel.

*NOTE: Do not remove the screws from the holders.*

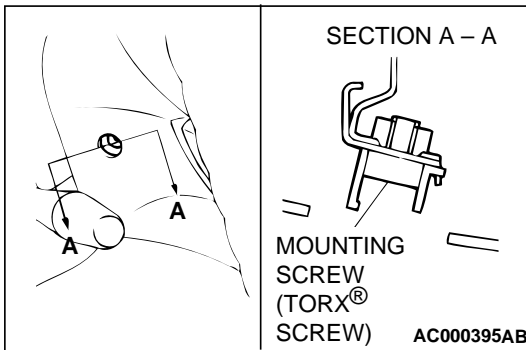

**⚠ WARNING**

*The removed air bag module should be stored in a clean, dry place with the pad cover face up.*

**⚠ CAUTION**

**When disconnecting the air bag module-to-clock spring connector, take care not to apply excessive force to it.**

2. When disconnecting the connector of the clock spring from the air bag module, press the air bag's lock toward the outer side to spread to open. Use a flat-tipped screwdriver, as shown in the figure at the left, to pry gently to remove the connector.

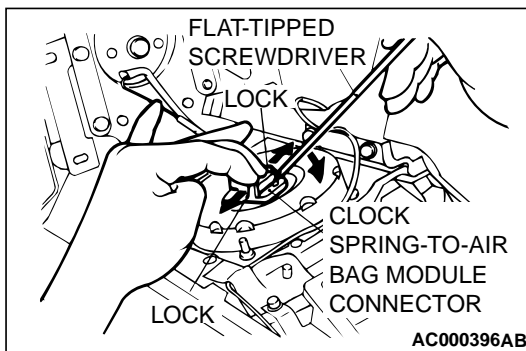

**<<C>> STEERING WHEEL REMOVAL**

**⚠ CAUTION**

**Do not hammer on the steering wheel. Doing so may damage the collapsible column mechanism.**

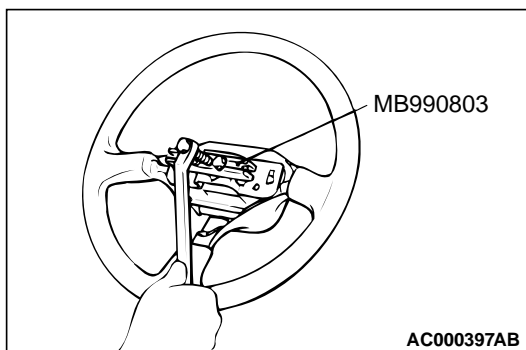

## &lt;&lt;D&gt;&gt; CLOCK SPRING REMOVAL

**⚠ WARNING**

*The removed clock spring should be stored in a clean, dry place.*

## &lt;&lt;E&gt;&gt; AIR BAG MODULE REMOVAL (FRONT PASSENGER'S SIDE)

**⚠ WARNING**

*The removed air bag module should be stored in a clean, dry place with the pad cover face up.*

## INSTALLATION SERVICE POINTS

## &gt;&gt;A&lt;&lt; PRE-INSTALLATION INSPECTION

**⚠ WARNING**

*Dispose of air bag modules only according to the specified procedure. (Refer to P.52B-80.)*

1. When installing the new air bag modules and clock spring, refer to "INSPECTION (P.52B-74)."
2. Connect the negative (-) battery cable.

**⚠ CAUTION**

**To prevent damage to scan tool MB991502, always turn the ignition, switch to "LOCK" (OFF) position before connecting or disconnecting scan tool MB991502.**

3. Connect scan tool MB991502 to the data link connector.
4. Turn the ignition switch to "ON" position.
5. Conduct diagnostic test using scan tool MB991502 to ensure entire SRS operates properly.

**⚠ DANGER**

**Wait at least 60 seconds after disconnecting the battery cable before doing any further work. (Refer to P.52B-15.)**

**⚠ WARNING**

**Battery posts, terminals and related accessories contain lead and lead compounds. WASH HANDS AFTER HANDLING.**

6. Turn the ignition switch to "LOCK" (OFF) position. Disconnect the negative (-) battery cable and tape the terminal to prevent accidental connection and air bags deployment.

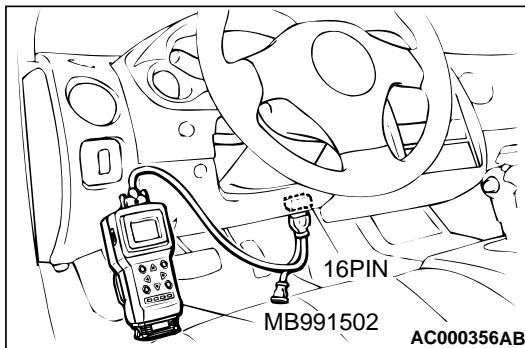



>>B<< CLOCK SPRING INSTALLATION

**⚠ WARNING**

*Ensure that the clock spring's mating marks are properly aligned. If not, the steering wheel may not rotate completely during a turn, or the flat cable in the clock spring could be damaged. This would prevent normal SRS operation and possibly cause serious injury to the driver.*

Align the mating marks of the clock spring. Turn the front wheels to the straight-ahead position. Then install the clock spring to the column switch.

<Mating Mark Alignment>

Turn the clock spring clockwise fully. Then turn it back approximately 3 turns counterclockwise to align the mating marks.

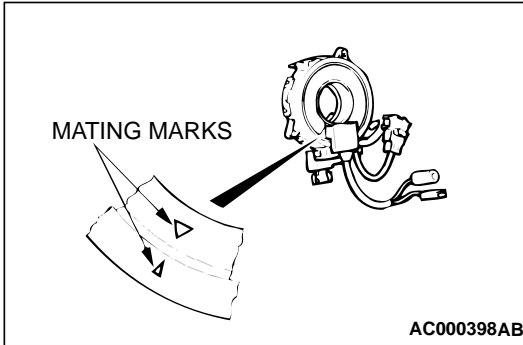

>>C<< STEERING WHEEL INSTALLATION

**⚠ CAUTION**

**When installing the steering wheel, ensure that the harness of the clock spring does not become caught or tangled.**

1. Before installing the steering wheel, turn the vehicle's front wheels to the straight-ahead position and align the mating marks of the clock spring.
2. After securing the steering wheel, turn the steering wheel all the way in both directions to confirm that the steering wheel rotation is normal.

>>D<< AIR BAG MODULE INSTALLATION (DRIVER'S SIDE)

**⚠ CAUTION**

**If there is gap at place B shown in the illustration, that means the connector is not firmly inserted, i.e. not correctly connected. In such a case, insert connector to the place, where there remains no gap at place B shown in the illustration.**

1. Connect the clock spring connector securely.

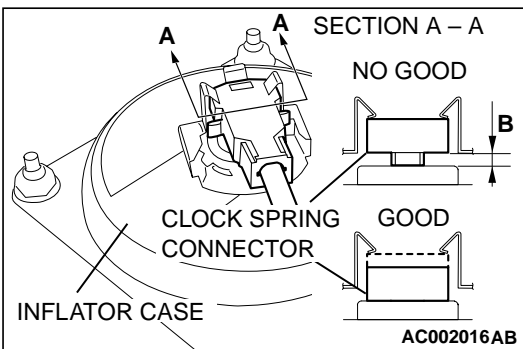

2. Tighten the air bag module mounting screws to  $9.0 \pm 2.0$  N·m ( $78 \pm 17$  in-lb)

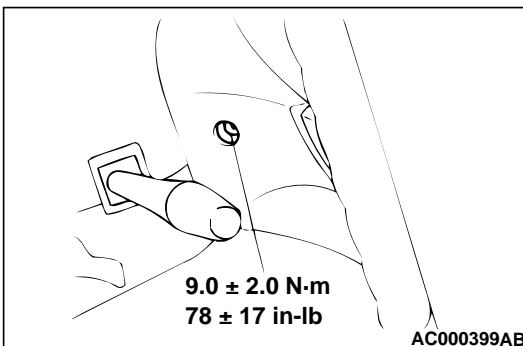

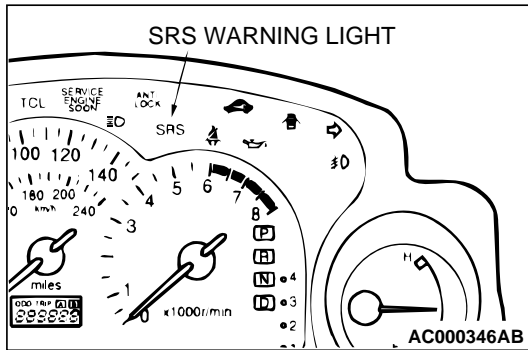
**>>E<< POST-INSTALLATION INSPECTION**

1. Reconnect the negative (-) battery cable.
2. Turn the ignition switch to "ON" position.
3. Does the "SRS" warning light illuminate for approximately 7 seconds, and then remain off for at least 5 seconds after turning "OFF"?
4. If yes, the SRS system is functioning properly. If no, refer to [P.52B-56](#).

**INSPECTION**

M1524002500079

**AIR BAG MODULE CHECK****⚠ WARNING**

- ***If any component damage is found during the following inspection, replace the air bag module with a new one. Dispose of the old one according to the specified procedure. (Refer to P.52B-80.)***
- ***Never attempt to measure the circuit resistance of the air bag modules (squib) even if you are using the specified tester. If the circuit resistance is measured with a tester, accidental air bag deployment will result in serious personal injury.***

1. Check the pad cover for dents, cracks or deformation.
2. Check the connectors for damage, the terminals for deformation, and the harness for binds.
3. Check the air bag inflator vase for dents, cracks or deformation.
4. Install the air bag module (driver's side) to the steering wheel and check fit and alignment with the wheel.
5. Install the air bag module (front passenger's side) to the instrument panel and crossmember and check fit and alignment.
6. Install the air bag module cover (front passenger's side) to the instrument panel to check fit and alignment.

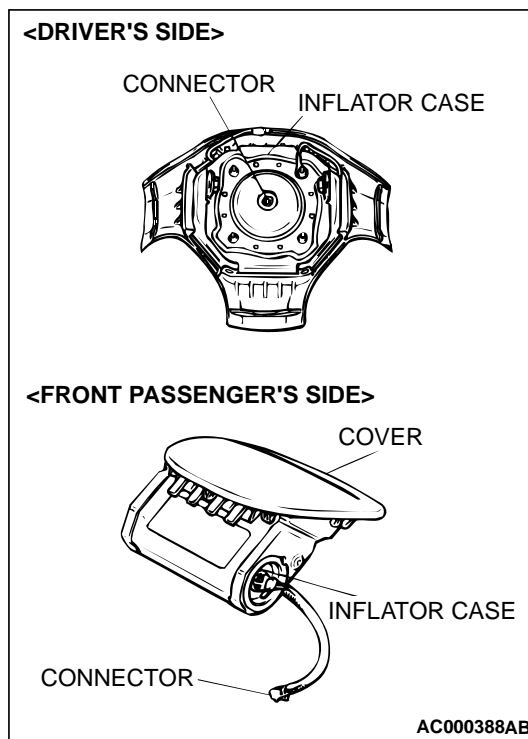

FRONT SEATBACK ASSEMBLY WITH SIDE AIR BAG  
MODULE CHECK

**⚠ WARNING**

- *If any improper part is found during the following inspection, replace the front seatback assembly with a new one. Dispose of the old one according to the specified procedure. (Refer to P.52B-80.)*
- *Never attempt to measure the circuit resistance of the air bag module (squib) even if you are using the specified tester. If the circuit resistance is measured with a tester, accidental air bag deployment will result in serious personal injury.*

1. Check the air bag module deployment section for dents or deformation.
2. Check connector for damage, terminals for deformation, and harness for binds.

**CLOCK SPRING CHECK**

If any malfunction is found in steps 1 through 4, replace the clock spring with a new one.

1. Check the connectors and protective tube for damage, and the terminals for deformation.
2. Visually check the case for damage.

3. Align the paint mark of special tool MB991613 connector number 4 with the notch in clock spring connector number 2 (arrow in the illustration) to connect the connectors number 2 and 4.
4. Measure the resistance between the terminals 22 and 23 of special tool MB991613 connector number 5.

**Standard value: less than 0.4 Ω**

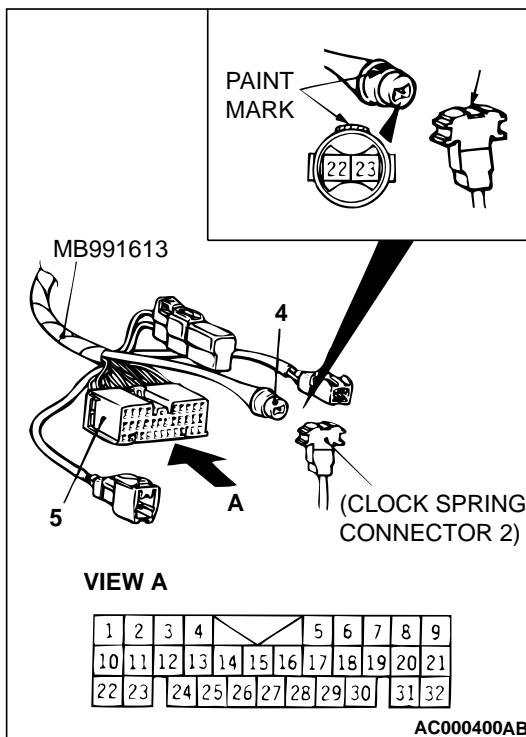
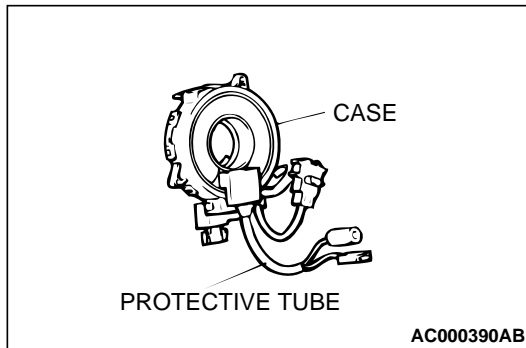
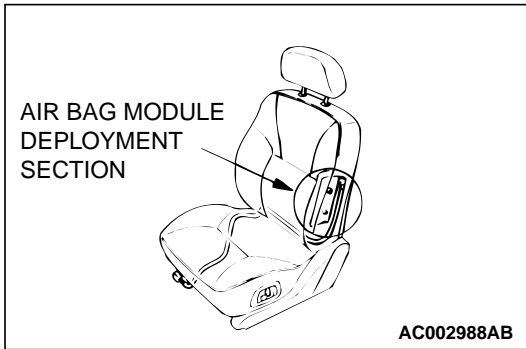

---

## SIDE IMPACT SENSOR

### REMOVAL AND INSTALLATION

M1524004600050

A side impact sensor is installed behind the center pillar trim on both driver and passenger sides of the vehicle.

** WARNING**

- *Never attempt to disassemble or repair the side impact sensor. If faulty, replace it.*
- *Do not drop or subject the side impact sensor to impact or vibration. Replace the side impact sensor, if dents, cracking, deformation, or rust are present.*
- *Replace the side impact sensor after the air bag has deployed.*

**REMOVAL AND INSTALLATION**

Pre-removal Operation	Post-installation Operation
<ul style="list-style-type: none"> <li>• Turn the ignition key to "LOCK" (OFF) position.</li> <li>• Rear Seat Cushion Removal (Refer to GROUP 52A, Rear Seat P.52A-23.)</li> <li>• Rear Seat Belt Removal (Refer to Rear Seat Belt P.52A-30.)</li> <li>• Quarter Trim, Lower Removal (Refer to GROUP 52A, Trims P.52A-10.)</li> </ul>	<ul style="list-style-type: none"> <li>• Quarter Trim, Lower Installation (Refer to GROUP 52A, Trims P.52A-10.)</li> <li>• Rear Seat Belt Installation (Refer to Rear Seat Belt P.52A-30.)</li> <li>• Rear Seat Cushion Installation (Refer to GROUP 52A, Rear Seat P.52A-23.)</li> </ul>

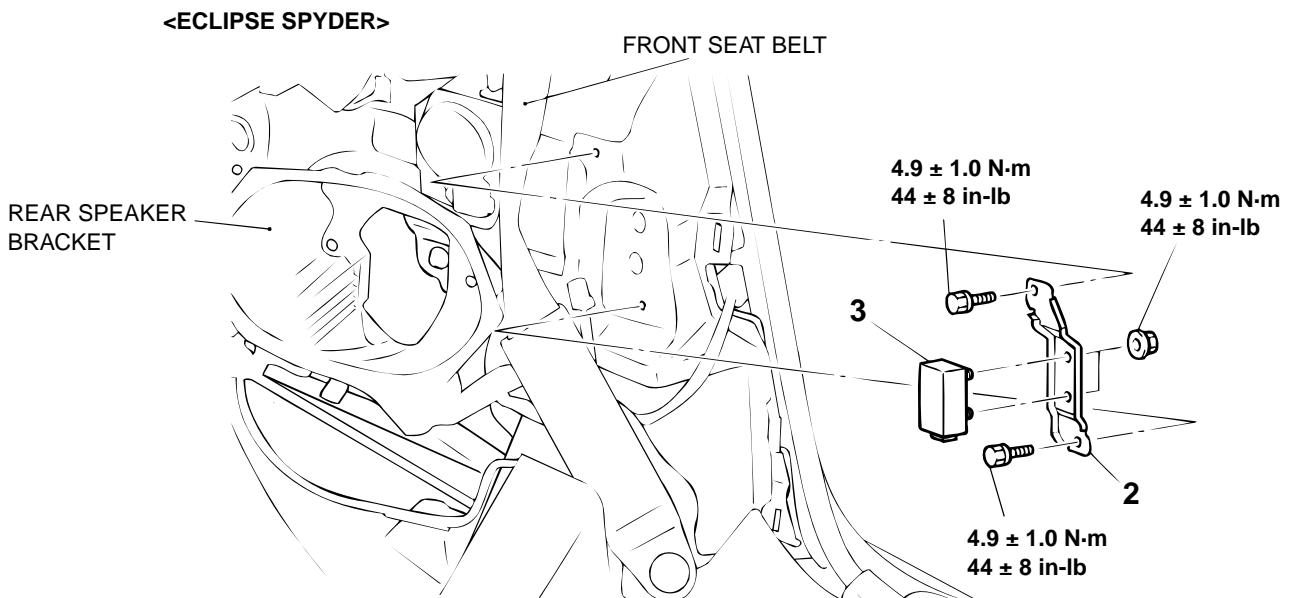
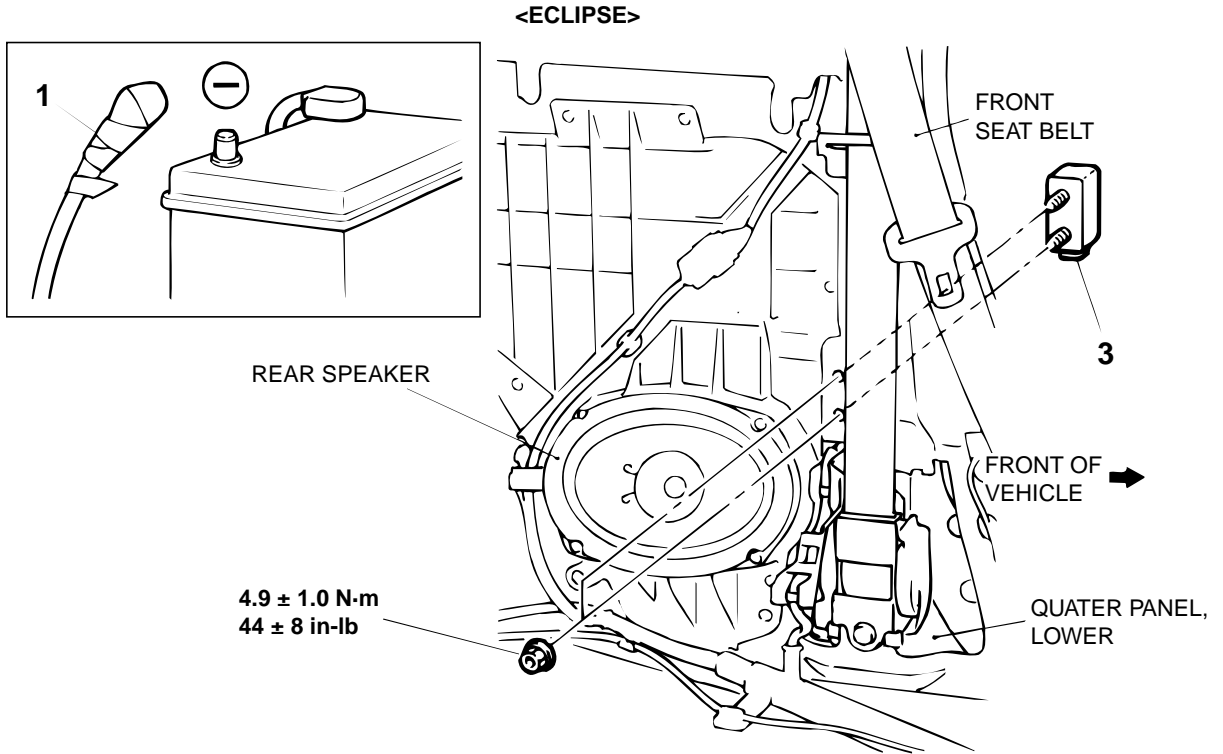

AC003133AB

<<A>>	REMOVAL STEPS	>>A<<	INSTALLATION STEPS
	1. NEGATIVE (-) BATTERY CABLE CONNECTION	>>B<<	• PRE-INSTALLATION INSPECTION
	2. SIDE IMPACT SENSOR BRACKET		3. SIDE IMPACT SENSOR
	3. SIDE IMPACT SENSOR		2. SIDE IMPACT SENSOR BRACKET
			1. NEGATIVE (-) BATTERY CABLE CONNECTOR
		>>C<<	• POST-INSTALLATION INSPECTION

*NOTE: The illustration above shows the side impact sensor (RH). The position of the side impact sensor (LH) is symmetrical to this.*

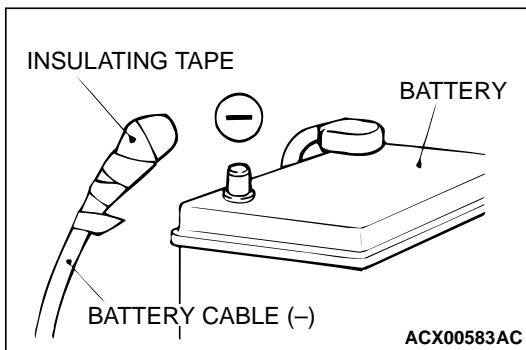

### REMOVAL SERVICE POINT

#### <<A>> NEGATIVE (-) BATTERY CABLE DISCONNECTION

##### **⚠ DANGER**

***Wait at least 60 seconds after disconnecting the battery cable before doing any further work. (Refer to P.52B-15.)***

##### **⚠ WARNING**

***Battery posts, terminals and related accessories contain lead and lead compounds. WASH HANDS AFTER HANDLING.***

Disconnect the negative (-) battery cable from the battery and tape the terminal to prevent accidental connection and air bag deployment.

### INSTALLATION SERVICE POINTS

#### >>A<< PRE-INSTALLATION INSPECTION

Check the side impact sensor for dents, breakage and bending and measure the resistance between the terminals, even when installing a new side impact sensor.

>>B<< SIDE IMPACT SENSOR INSTALLATION

**⚠ WARNING**

***If the side impact sensor is not installed securely and correctly, the side air bag may not operate normally. Securely connect the connector.***

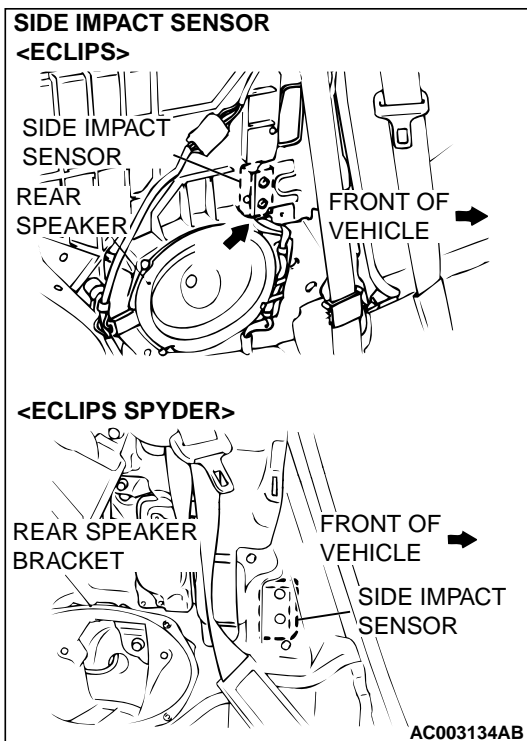

>>C<< POST-INSTALLATION INSPECTION

1. Reconnect the negative (-) battery cable.
2. Turn the ignition switch to "ON" position.
3. Does the "SRS" warning light illuminate for approximately 7 seconds, and then remain off for at least 5 seconds after turning "OFF"?
4. If yes, the SRS system is functioning properly. If no, refer to [P.52B-56](#).

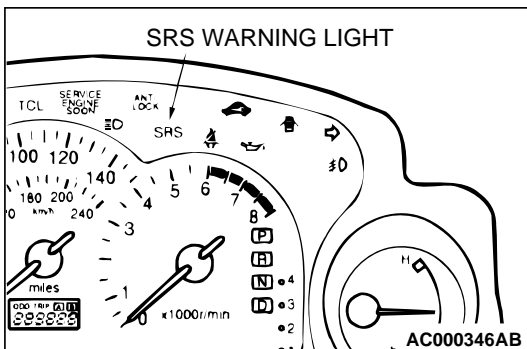

**INSPECTION**

M1524004700057

**⚠ WARNING**

***If a dent, crack, deformation or rust is detected, replace with a new sensor.***

*NOTE: For checking of the side impact sensor other than described above, refer to the section concerning SRS diagnosis (Refer to [P.52B-18](#).)*

- Check the side impact sensor and bracket for dents, cracks or deformation.
- Check the connector for damage, and terminal for deformation.
- Check that there is no bending or corrosion in the center pillar.

# AIR BAG MODULE DISPOSAL PROCEDURES

M1524001200075

Before disposing of an air bag or a vehicle equipped with an air bag, follow the procedures below to deploy the air bag.

## UNDEPLOYED AIR BAG MODULE DISPOSAL

### Required Special Tools:

MB628919 or MR203491: SRS Air Bag Adapter Harness C

MB686560: SRS Air Bag Adapter Harness B

MR372530: SRS Air Bag Adapter Harness A

### **WARNING**

- ***If the vehicle is to be scrapped or otherwise disposed of, deploy the air bags inside the vehicle. If the vehicle will continue to be used and only the air bag modules are to be disposed of, deploy the air bags outside the vehicle.***
- ***Since a large amount of smoke is produced when the air bag is deployed, avoid residential areas whenever possible.***
- ***Since there is loud noise when the air bags are deployed, avoid residential areas whenever possible. If anyone is nearby, give warning of the impending noise.***
- ***Suitable ear protection should be worn by personnel performing these procedures or by people in the immediate area.***

**DEPLOYMENT INSIDE THE VEHICLE (when disposing of a vehicle) <Air bag module (driver's side)>**

1. Move the vehicle to an isolated spot.

### **DANGER**

***Wait at least 60 seconds after disconnecting the battery cables before doing any further work. (Refer to [P.52B-15](#).)***

### **WARNING**

***Battery posts, terminals and related accessories contain lead and lead compounds. WASH HANDS AFTER HANDLING.***

2. Disconnect the negative (-) and positive (+) battery cables from the battery terminals, and then remove the battery from the vehicle. (Refer to GROUP 54A, Battery [P.54A-8](#).)



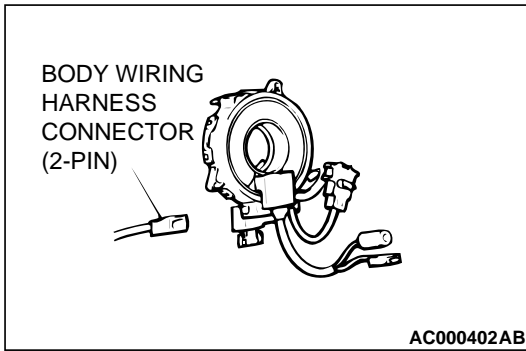

3. Remove the steering column cover lower.
4. Remove the connection between the clock spring 2-pin connector and the body wiring harness connector.
 

*NOTE: If the clock spring connector is disconnected from the body wiring harness, both electrodes of the clock spring connector will be automatically shorted to prevent unintended deployment of the air bag due to static electricity, etc.*

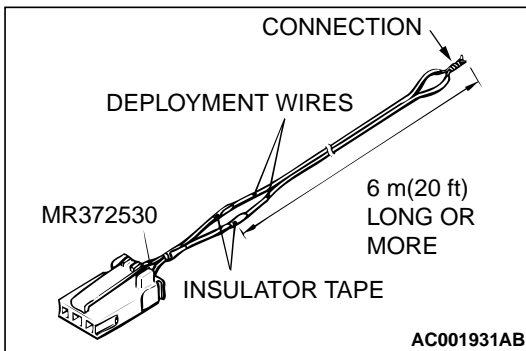

5. Connect deployment wires, each 6 meters (20 feet) or longer, to the two leads of special tool MR372530, and cover the connections with insulation tape. The other ends of the deployment wires should be connected to each other (short-circuited), to prevent sudden unexpected deployment of the air bag module.

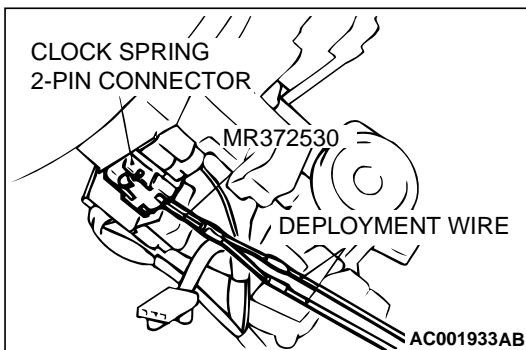

6. Connect the clock spring two-pin connector to special tool MR372530 and move the deployment wires out of the vehicle.

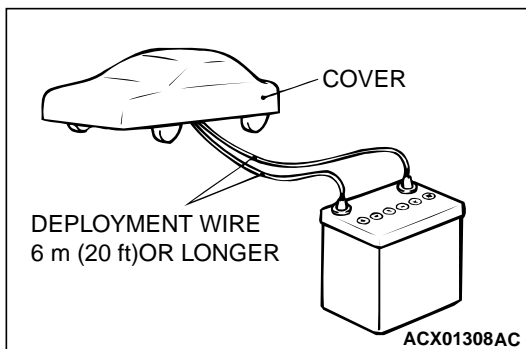

- ⚠ WARNING**  
***If the glass is scratched, air bag deployment could cause it to crack and fly out of the vehicle, so always put a cover over the vehicle.***
7. To suppress the operation sound as much as possible completely close all door windows, close the doors and put the cover on the vehicle.

**⚠ WARNING**

- **Before deploying the air bag in this manner, first check to be sure that there is no one in or near the vehicle. Wear safety glasses.**
  - **The inflator will be quite hot immediately following the deployment, so wait at least 30 minutes to allow it to cool before attempting to handle it. Although not poisonous, do not inhale gas from the air bag deployment. See Deployed Air Bag Module Disposal Procedures (Refer to P.52B-90.) for post-deployment handling instructions.**
  - **If the air bag module fails to deploy, do not go near the module. Contact the MMSA Tech Line.**
8. At a location as far away from the vehicle as possible, disconnect the two connected wires from each other, and connect them to the two terminals of the battery (which has been removed from the vehicle) to deploy the air bag
  9. After deployment, dispose of the air bag module according to the Deployed Air Bag Module Disposal Procedures. (Refer to P.52B-90.)

**DEPLOYMENT INSIDE THE VEHICLE (when disposing of a vehicle) <Air bag module (front passenger's side)>**

1. Move the vehicle to an isolated spot.

**⚠ DANGER**

**Wait at least 60 seconds after disconnecting the battery cables before doing any further work. (Refer to P.52B-15.)**

**⚠ WARNING**

**Battery posts, terminals and related accessories contain lead and lead compounds. WASH HANDS AFTER HANDLING.**

2. Disconnect the negative (-) and positive (+) battery cables from the battery terminals, and then remove the battery from the vehicle. (Refer to GROUP 54A, Battery P.54A-8.)
3. Remove the glove box.
4. Remove the connection between the air bag module (front passenger's side) connector (red two-pin) and the body wiring harness connector.

**NOTE:** *If the air bag module connector is disconnected from the body wiring harness, both electrodes of the air bag module connector will be automatically shorted to prevent unintended deployment of the air bag due to static electricity, etc.*

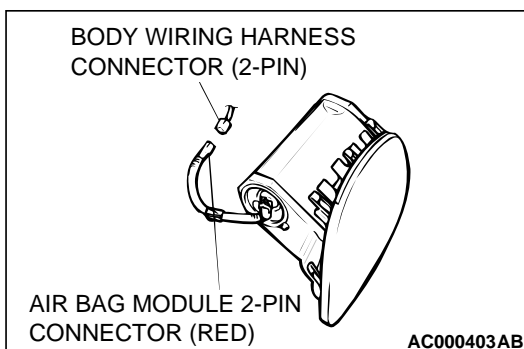

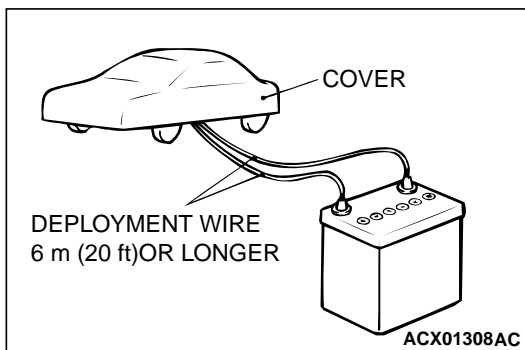
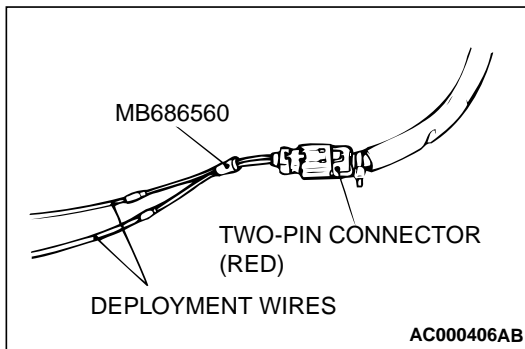
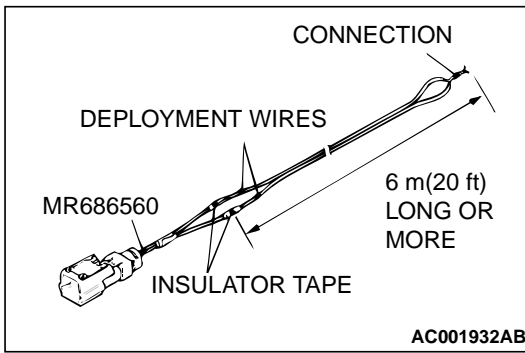

5. Connect deployment wires, each 6 meters (20 feet) or longer, to the two leads of special tool MB686560, and cover the connections with insulation tape. The other ends of the deployment wires should be connected to each other (short-circuited), to prevent sudden unexpected deployment of the air bag module.
6. Connect the clock spring, air bag module (front passenger's side) two-pin connector to special tool MB686560 and move the deployment wires out of the vehicle.

**⚠ WARNING**

***If the glass is scratched, air bag deployment could cause it to crack and fly out of the vehicle, so always put a cover over the vehicle.***

7. To suppress the operation sound as much as possible completely close all door windows, close the doors and put the cover on the vehicle.

**⚠ WARNING**

- ***Before deploying the air bag in this manner, first check to be sure that there is no one in or near the vehicle. Wear safety glasses.***
  - ***The inflator will be quite hot immediately following the deployment, so wait at least 30 minutes to allow it to cool before attempting to handle it. Although not poisonous, do not inhale gas from the air bag deployment. See Deployed Air Bag Module Disposal Procedures (Refer to P.52B-90.) for post-deployment handling instructions.***
  - ***If the air bag module fails to deploy, do not go near the module. Contact the MMSA Tech Line.***
8. At a location as far away from the vehicle as possible, disconnect the two connected wires from each other, and connect them to the two terminals of the battery (which has been removed from the vehicle) to deploy the air bag
  9. After deployment, dispose of the air bag module according to the Deployed Air Bag Module Disposal Procedures. (Refer to P.52B-90.)

**DEPLOYMENT INSIDE THE VEHICLE (when disposing of a vehicle) <Side air bag module>**

1. Move the vehicle to an isolated spot.

**⚠ DANGER**

**Wait at least 60 seconds after disconnecting the battery cables before doing any further work. (Refer to P.52B-15.)**

**⚠ WARNING**

**Battery posts, terminals and related accessories contain lead and lead compounds. WASH HANDS AFTER HANDLING.**

2. Disconnect the negative (-) and positive (+) battery cables from the battery terminals, and then remove the battery from the vehicle. (Refer to GROUP 54A, Battery P.54A-8.)

**⚠ WARNING**

**The side air bag modules for both the driver's side and passenger's side should be deployed.**

3. To deploy the side air bag module: Remove the connection between the side air bag module connector (red two-pin) and the side air bag wiring harness connector.

*NOTE: If the air bag module connector is disconnected from the body wiring harness, both electrodes of the air bag module connector will be automatically shorted to prevent unintended deployment of the air bag due to static electricity, etc.*

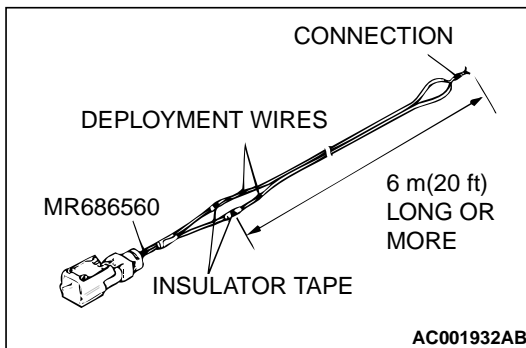
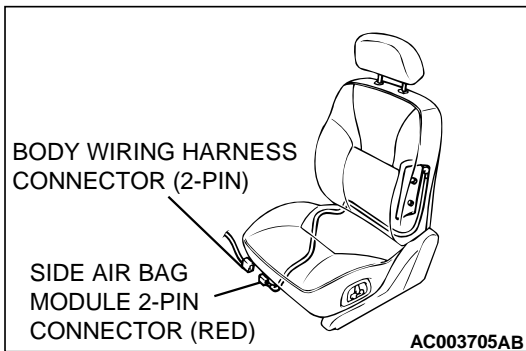

4. Connect deployment wires, each 6 meters (20 feet) or longer, to the two leads of special tool MB686560, and cover the connections with insulation tape. The other ends of the deployment wires should be connected to each other (short-circuited), to prevent sudden unexpected deployment of the air bag module.

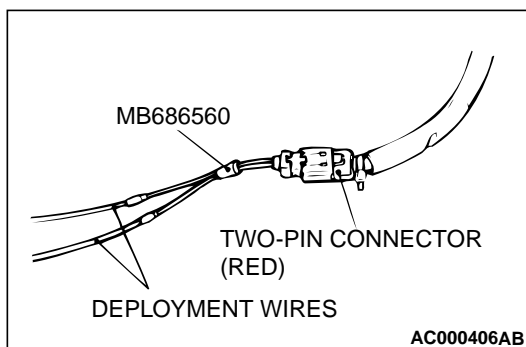

5. Connect the clock spring, side air bag module two-pin connector to special tool mb686560 and move the deployment wires out of the vehicle.

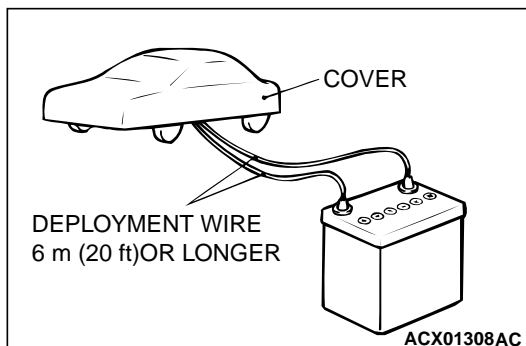

**⚠ WARNING**

***If the glass is scratched, air bag deployment could cause it to crack and fly out of the vehicle, so always put a cover over the vehicle.***

6. To suppress the operation sound as much as possible completely close all door windows, close the doors and put the vehicle.

**⚠ WARNING**

- ***Before deploying the air bag in this manner, first check to be sure that there is no one in or near the vehicle. Wear safety glasses.***
- ***The inflator will be quite hot immediately following the deployment, so wait at least 30 minutes to allow it to cool before attempting to handle it. Although not poisonous, do not inhale gas from the air bag deployment. See Deployed Air Bag Module Disposal Procedures (Refer to P.52B-90.) for post-deployment handling instructions.***
- ***If the air bag module fails to deploy, do not go near the module. Contact the MMSA Tech Line.***

7. At a location as far away from the vehicle as possible, disconnect the two connected wires from each other, and connect them to the two terminals of the battery (which has been removed from the vehicle) to deploy the air bag.
8. After deployment, Air bag Module Disposal Procedures. (Refer to P.52B-90.)

**DEPLOYMENT OUTSIDE THE VEHICLE <Air bag module (driver's side)>**

**⚠ DANGER**

***Wait at least 60 seconds after disconnecting the battery cables before doing any further work. (Refer to P.52B-15.)***

**⚠ WARNING**

- ***Battery posts, terminals and related accessories contain lead and lead compounds. WASH HANDS AFTER HANDLING.***
- ***Deploy the air bag in a wide, flat area at least 6 meters (20 feet) away from obstacles and other people.***
- ***Do not perform deployment outside if a strong wind is blowing. If there is a slight breeze, place the air bag module downwind from the battery.***

1. Disconnect the negative (-) and positive (+) battery cables from the battery terminals, and then remove the battery from the vehicle. (Refer to GROUP 54A, Battery P.54A-8.)

**⚠ WARNING**

**Store the air bag module on a flat surface with the pad cover facing up. Do not place anything on top of it.**

2. Remove the air bag module from the vehicle. (Refer to P.52B-69.)
3. Connect deployment wires, each 6 meters (20 feet) or longer, to the two leads of special tool MB628919 or MB203491, and cover the connections with insulation tape. The other ends of the deployment wires should be connected to each other (short-circuited), to prevent sudden unexpected deployment of the air bag module.

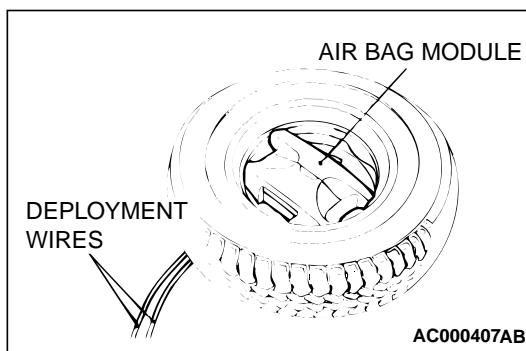
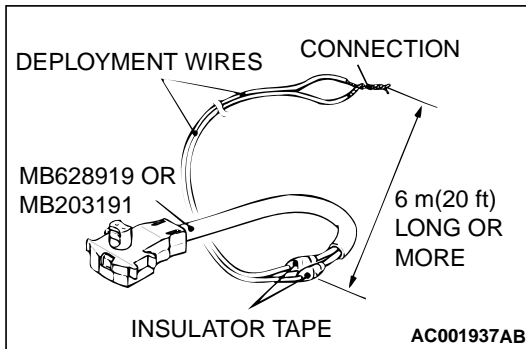

4. Take special tool MB628919 or MR203491 that is connected to the wires, pass it beneath an old tire wheel assembly, and connect it to the air bag module.

**⚠ CAUTION**

**The adapter harness below the wheel should be loose. If it is too tight, the reaction when the air bag deploys could damage the adaptor harness.**

5. Pass the thick wire through the air bag module mounting hole, and then secure the air bag module to an old tire with a wheel in it so that the pad on the module is facing upwards.
6. Place three old tires without wheels on top of the tire secured to the air bag module, and secure all tires together with ropes (four locations).

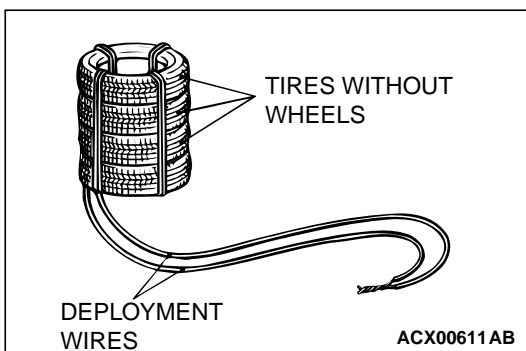

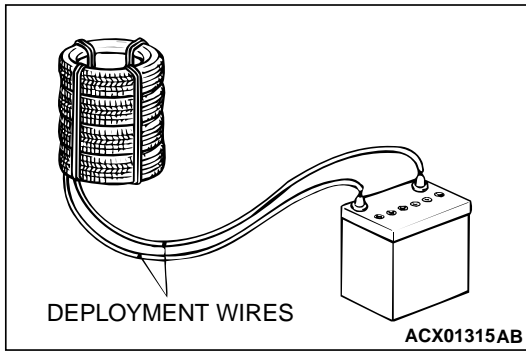

**⚠ WARNING**

- **Before deployment, check carefully to be sure that no one is nearby.**
  - **The inflator will be quite hot immediately following the deployment, so wait at least 30 minutes to allow it to cool before attempting to handle it. Although not poisonous, do not inhale gas from air bag deployment. See Deployed Air Bag Module Disposal Procedures (Refer to [P.52B-90.](#)) for post-deployment handling instructions.**
  - **If the air bag fails to deploy, do not go near the module. Contact the MMSA Tech Line.**
7. At a location as far away from the air bag module as possible, and from a shielded position, disconnect the two connected wires from each other, and connect them to the two terminals of the battery (which has been removed from the vehicle) to deploy the air bag.
  8. Discard the deployed air bag module as specified in Deployed Air Bag Module Disposal Procedures. (Refer to [P.52B-90.](#))

**DEPLOYMENT OUTSIDE THE VEHICLE <Air bag module (front passenger's side)>**

**⚠ DANGER**

**Wait at least 60 seconds after disconnecting the battery cables before doing any further work. (Refer to [P.52B-15.](#))**

**⚠ WARNING**

- **Battery posts, terminals and related accessories contain lead and lead compounds. WASH HANDS AFTER HANDLING.**
  - **Deploy the air bag in a wide, flat area at least 6 meters (20 feet) away from obstacles and other people.**
  - **Do not perform deployment outside if a strong wind is blowing. If there is a slight breeze, place the air bag module downwind from the battery.**
1. Disconnect the negative (-) and positive (+) battery cables from the battery terminals, and then remove the battery from the vehicle. (Refer to GROUP 54A, Battery [P.54A-8.](#))

**⚠ WARNING**

**Store the air bag module on a flat surface with the pad cover facing up. Do not place anything on top of it.**

2. Remove the air bag module from the vehicle. (Refer to [P.52B-69.](#))

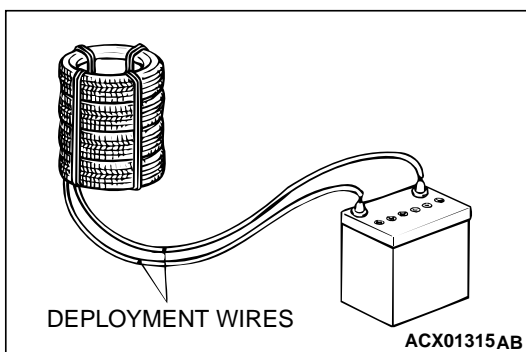
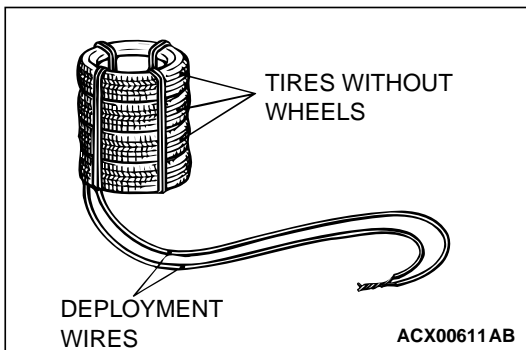
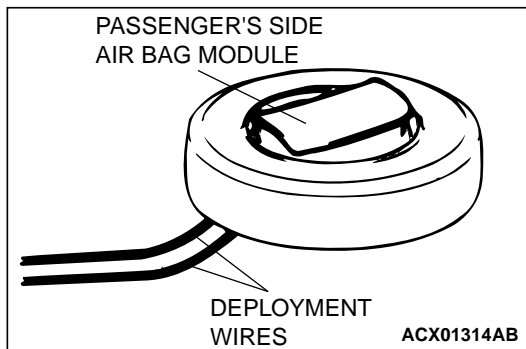
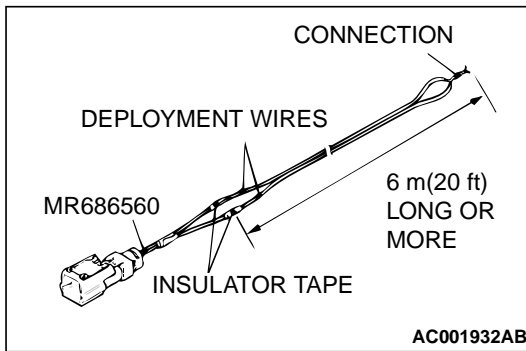

3. Connect two wires, each 6 meters (20 feet) or longer, to the two leads of special tool MB686560, and cover the connections with insulation tape. The other ends of the two wires should be connected to each other (short-circuited), to prevent sudden unexpected deployment of the air bag module.

4. Connect the deployment wires to special tool MB686560, pass it beneath the tire and wheel assembly, and connect it to the air bag module.

**⚠ CAUTION**

- Leave some space below the wheel for the deployment wires. If there is no space, the reaction of the air bag deployment could result in damage of the adaptor harness.
  - During deployment, the connector of special tool MB686560 must not be between the tires.
5. Pass the thick wire through the air bag module mounting hole, and then secure the air bag module to an old tire with a wheel in it so that the pad on the module is facing upwards.
  6. Place three old tires without wheels on top of the tire secured to the air bag module, and secure all tires together with ropes (four locations).

**⚠ WARNING**

- Before deployment, check carefully to be sure that no one is nearby.
  - The inflator will be quite hot immediately following the deployment, so wait at least 30 minutes to allow it to cool before attempting to handle it. Although not poisonous, do not inhale gas from air bag deployment. See Deployed Air Bag Module Disposal Procedures (Refer to P.52B-90.) for post-deployment handling instructions.
  - If the air bag fails to deploy, do not go near the module. Contact the MMSA Tech Line.
7. At a location as far away from the air bag module as possible, and from a shielded position, disconnect the two connected wires from each other, and connect them to the two terminals of the battery (which has been removed from the vehicle) to deploy the air bag.



- Discard the deployed air bag module as specified in Deployed Air Bag Module Disposal Procedures. (Refer to P.52B-90.)

**DEPLOYMENT OUTSIDE VEHICLE <Side air bag module>**

- Remove the front seatback assembly with side air bag module from the vehicle. (Refer to P.52A-18.)

**⚠ CAUTION**

Once disconnected, both electrodes of the side air bag module connector short automatically to prevent accidental deployment caused by static etc. Still, in consideration of the accidental deployment, store the air bag module on flat place with deployment surface facing up. Also, do not put anything on it.

- Connect deployment wires 6 m (20 feet) or longer with the SRS air bag adapter harness respectively. Insulate the connections with tape.

Also, connect the other ends of the deployment wires each other to short, thereby preventing the side air bag from accidental deployment caused by static etc.

- Place the front seat back assembly with its back contact with the ground.
- Connect the SRS air bag adapter harness with the deployment wires to the side air bag module connector.

**⚠ CAUTION**

- Before the deployment, see that no one is near the front seatback assembly.
- The deployment makes the inflator of the side air bag very hot. Before handling the inflator, wait more than 30 minutes for cooling.
- If the side air bag module fails to deploy although the procedure is respected, do not go near the module. Contact the MMSA Tech Line.

- Disconnect the deployment wires as far from the front seat back assembly possible and connect the harnesses to the battery removes from the vehicle. Then, deploy.
- Remove the deployed air bag module from the seatback assembly and discard as specified in the procedure. (P.52B-90)

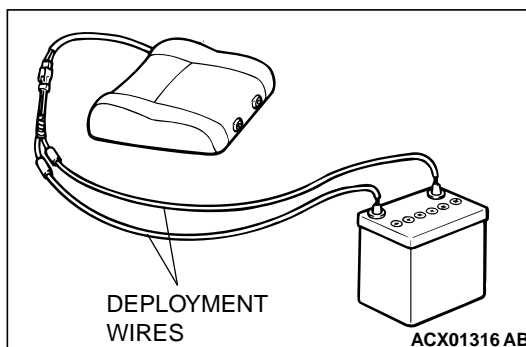
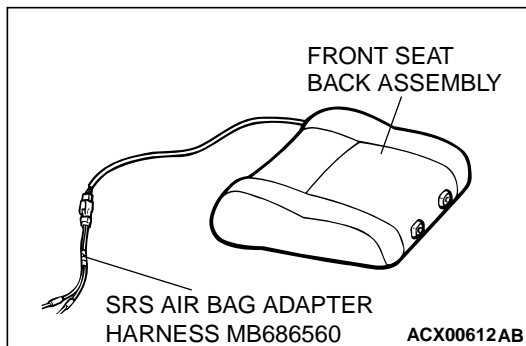
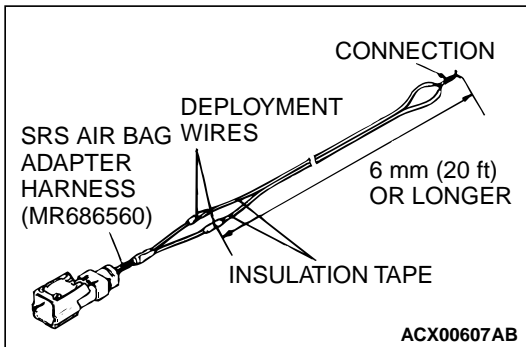

**DEPLOYED AIR BAG MODULE DISPOSAL**

After deployment, the air bag module should be disposed of in the same manner as any other scrap parts, adhering to local laws and/or legislation. Observe the following precautions during air bag disposal:

1. The inflator will be quite hot immediately following deployment, so wait at least 30 minutes to allow it cool before attempting to handle it.
2. Do not put water or oil on the air bag after deployment.

**⚠ WARNING**

***If after following these precautions, any material does get into the eyes or on the skin, immediately rinse the affected area with a large amount of clean water. If any irritation develops, seek medical attention.***

3. There may be material on the deployed air bag module, that could irritate the eye and/or skin. Wear gloves and safety glasses when handling a deployed air bag module.
4. Tightly seal the air bag module in a strong plastic bag for disposal.
5. Be sure to always wash your hands after completing this operation.

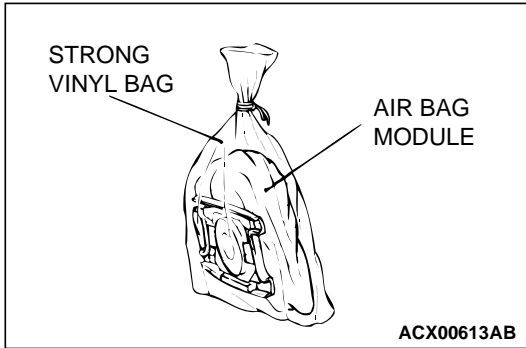

**SPECIFICATIONS**

**SPECIFICATIONS**

M1524004900073

**FASTENER TIGHTENING SPECIFICATIONS**

ITEMS	SPECIFICATIONS
Air bag module (driver's side) mounting screw	9.0 ± 2.0 N·m (78 ± 17 in-lb)
Side impact sensor bracket bolt	4.9 ± 1.0 N·m (44 ± 8 in-lb)
Side impact sensor mounting nut	4.9 ± 1.0 N·m (44 ± 8 in-lb)
SRS-ECU mounting bolt	4.9 ± 1.0 N·m (44 ± 8 in-lb)
Steering wheel nut	41 ± 8 N·m (31 ± 5 ft-lb)

**SERVICE SPECIFICATIONS**

M1524000400065

ITEM	STANDARD VALUE
Clock spring resistance Ω	Less than 0.4