

GROUP 37A

POWER STEERING**CONTENTS**

GENERAL DESCRIPTION	37A-2	STEERING WHEEL AND SHAFT ASSEMBLY	37A-20
POWER STEERING DIAGNOSIS . . .	37A-2	REMOVAL AND INSTALLATION	37A-20
INTRODUCTION TO POWER STEERING DIAGNOSIS	37A-2	DISASSEMBLY AND ASSEMBLY	37A-21
POWER STEERING DIAGNOSIS TROUBLESHOOTING STRATEGY	37A-3	POWER STEERING GEAR BOX ASSEMBLY	37A-23
SYMPTOM CHART	37A-3	REMOVAL AND INSTALLATION	37A-23
SYMPTOM PROCEDURES	37A-3	INSPECTION	37A-25
SPECIAL TOOLS	37A-11	DISASSEMBLY AND ASSEMBLY	37A-26
ON-VEHICLE SERVICE	37A-13	INSPECTION	37A-36
STEERING WHEEL FREE PLAY CHECK	37A-13	TIE ROD END BALL JOINT DUST COVER REPLACEMENT	37A-36
STEERING ANGLE CHECK	37A-14	POWER STEERING OIL PUMP ASSEMBLY	37A-37
TIE ROD END BALL JOINT BREAKAWAY TORQUE CHECK	37A-14	REMOVAL AND INSTALLATION	37A-37
STATIONARY STEERING EFFORT CHECK	37A-15	INSPECTION	37A-37
STEERING WHEEL RETURN TO CENTER CHECK	37A-16	DISASSEMBLY AND ASSEMBLY	37A-38
DRIVE BELT TENSION CHECK	37A-16	INSPECTION	37A-39
FLUID LEVEL CHECK	37A-16	POWER STEERING HOSES	37A-40
FLUID REPLACEMENT	37A-16	REMOVAL AND INSTALLATION	37A-40
POWER STEERING SYSTEM BLEEDING OIL PUMP PRESSURE TEST	37A-17	SPECIFICATIONS	37A-45
POWER STEERING PRESSURE SWITCH CHECK	37A-19	FASTENER TIGHTENING SPECIFICATIONS	37A-45
BALL JOINT DUST COVER CHECK	37A-19	GENERAL SPECIFICATIONS	37A-46
		SERVICE SPECIFICATIONS	37A-46
		LUBRICANTS	37A-47
		SEALANTS	37A-47

GENERAL DESCRIPTION

The vehicle uses engine speed-responsive hydraulic power steering. The steering wheel has three spokes. In addition, all vehicles are equipped with SRS (Supplemental Restraint System).

The steering column in all vehicles has a shock absorber mechanism and a tilt steering mechanism. A vane-type oil pump with a fluid flow control system has been included. The steering gear and linkage is rack and pinion type.

M1372000100070

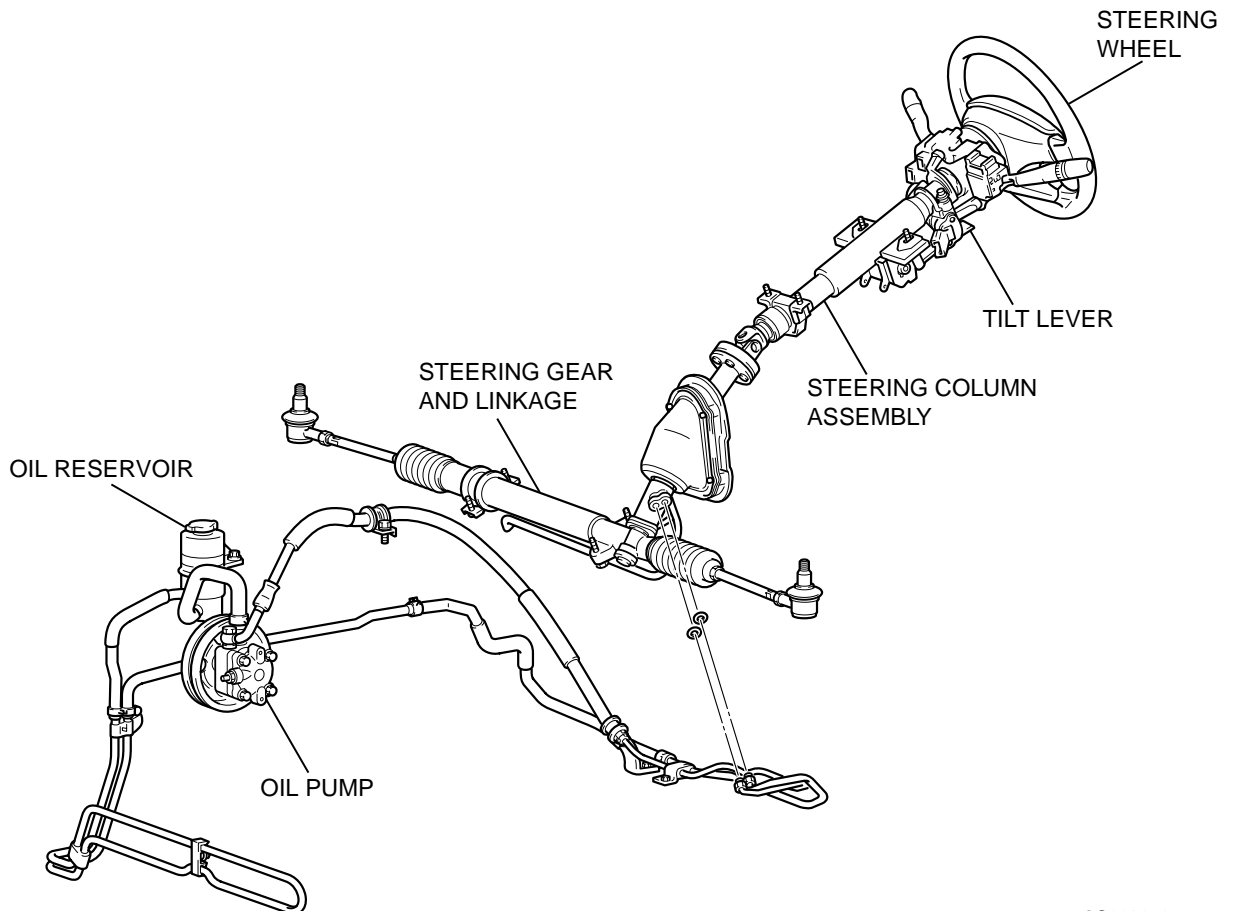

AC003276 AB

POWER STEERING DIAGNOSIS

INTRODUCTION TO POWER STEERING DIAGNOSIS

M1372008500061

Hydraulic power steering is used for all vehicles. Faults in the power steering can include excessive play of the steering wheel, difficult steering wheel operation, noise, vibration, and oil leaks, etc. Possible causes of these faults can include defects in the gear box, oil pump or steering linkage.

POWER STEERING DIAGNOSIS TROUBLESHOOTING STRATEGY

M1372007300064

Use these steps to plan your diagnostic strategy. If you follow them carefully, you will be sure that you have exhausted most of the possible ways to find a power steering fault.

1. Gather information from the customer.

2. Verify that the condition described by the customer exists.

3. Find the malfunction by following the Symptom Chart.

4. Verify malfunction is eliminated.

SYMPTOM CHART

M1372007600065

SYMPTOMS	INSPECTION PROCEDURE	REFERENCE PAGE
Excessive play of steering wheel	1	P.37A-3
Difficult steering wheel operation (insufficient power assist)	2	P.37A-4
Rattling noise	3	P.37A-6
Shrill noise	4	P.37A-6
Squealing noise	5	P.37A-7
Hissing noise	6	P.37A-7
Droning noise	7	P.37A-7
Squeaking noise	8	P.37A-8
Vibration	9	P.37A-9
Oil leakage from hose connection	10	P.37A-9
Oil leakage from hose assembly	11	P.37A-9
Oil leakage from oil reservoir	12	P.37A-10
Oil leakage from oil pump	13	P.37A-10
Oil leakage from gear box	14	P.37A-10

SYMPTOM PROCEDURES

INSPECTION PROCEDURE 1: Excessive Play of Steering Wheel

DIAGNOSIS

STEP 1. Check for looseness at the steering shaft coupling section and at the steering wheel linkage.

Q: Is there any looseness?

YES : Repair or replace the part. Then go to Step 3.

NO : Go to Step 2.

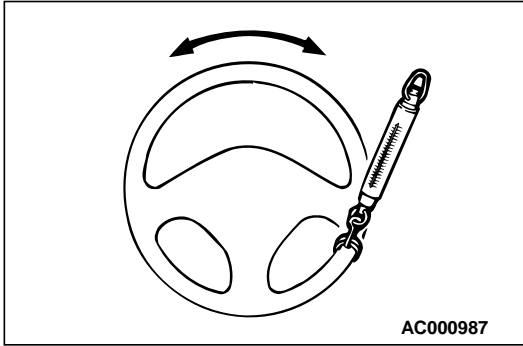
**STEP 2. Check the steering wheel free play.**

- (1) With engine running (hydraulic operation), set front wheels straight ahead.
- (2) Measure the play on steering wheel circumference before wheels start to move when slightly moving the steering wheel in both directions.

Limit: 30 mm (1.2 inch)

- (3) If the free play exceeds the limit value, set steering wheel straight ahead with engine stopped. Load approximately 5 N (1.1 pound) toward steering circumference and check play.

Standard value (steering wheel play with engine stopped): 10 mm (0.4 inch) or less

Q: Does the play exceed the standard value?

YES : Remove steering gear box (Refer to [P.37A-23.](#)) and check total pinion torque (Refer to [P.37A-25.](#)). Then go to Step 3.

NO : Go to Step 3.

STEP 3. Check steering wheel play.

Verify that the steering wheel play is not excessive.

Q: Is the steering wheel play excessive?

YES : Repeat to Step 1.

NO : Diagnosis is complete.

INSPECTION PROCEDURE 2: Difficult Steering Wheel Operation (Insufficient Power Assist)**DIAGNOSIS****STEP 1. Check the power steering belt tension.**

Refer to GROUP 00, Maintenance Service – Drive Belts [P.00-40.](#)

Q: Is the power steering belt tension within the standard value?

YES : Go to Step 2.

NO : Adjust the tension. (Refer to GROUP 00, Maintenance Service – Drive Belts [P.00-40.](#)) Then go to Step 10.

STEP 2. Check the belt for damage.**Q: Is the belt damaged?**

YES : Replace the belt. Then go to Step 10.

NO : Go to Step 3.

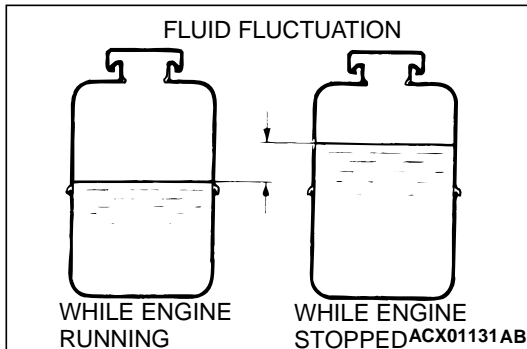

STEP 3. Check the fluid level.

- (1) Park the vehicle on a flat, level surface, start the engine, and then turn the steering wheel several times to raise the temperature of the fluid to approximately 50 – 60°C (122 – 140°F).
- (2) With the engine running, turn the wheel all the way to the left and right several times.
- (3) Check the fluid in the oil reservoir for foaming or milkiness. Check the difference of the fluid level when the engine is stopped, and while it is running. If the change of the fluid level is 5 mm (0.2 inch) or more, bleed air from the system. (Refer to [P.37A-17.](#))

Q: Is fluid foamy?

- YES :** Go to Step 10.
NO : Go to Step 4.

STEP 4. Check for entry of air.

Q: Has air entered?

- YES :** Bleed the air (Refer to [P.37A-17.](#)). Then go to Step 10.
NO : Go to Step 5.

STEP 5. Check each hose for crushing or twisting.

Q: Is there fault?

- YES :** Repair or replace the hose. Then go to Step 10.
NO : Go to Step 6.

STEP 6. Check for oil leaks.

Q: Are there oil leaks?

- YES :** Repair it. Then go to Step 10.
NO : Go to Step 7.

STEP 7. Check the wheel alignment (camber and caster).

Refer to GROUP 33A, On-vehicle Service – Front Wheel Alignment Check and Adjustment [P.33A-6.](#)

Q: Is there fault?

- YES :** Repair it. Then go to Step 10.
NO : Go to Step 8.

STEP 8. Check the gear box rack piston seal for damage.

Q: Is there damage?

- YES :** Replace it. Then go to Step 10.
NO : Go to Step 9.

STEP 9. Check for excessive tie rod end ball joint breakaway torque.Refer to [P.37A-14](#).**Q: Is there fault?****YES** : Replace the part. Then go to Step 10.**NO** : Go to Step 10.**STEP 10. Check steering wheel operation.**

Verify that steering wheel operation is not difficult.

Q: Is the steering wheel operation difficult?**YES** : Repeat from Step 1.**NO** : Diagnosis is complete.**INSPECTION PROCEDURE 3: Rattling Noise****DIAGNOSIS****STEP 1. Check for proper oil pump and gear box installation.****Q: Is the oil pump and gear box installation correct?****YES** : Go to Step 2.**NO** : Repair it. Then go to Step 4.**STEP 2. Check for interference of other parts with the steering column and power steering hoses.****Q: Is there interference?****YES** : Correct the interference. Then go to Step 4.**NO** : Go to Step 3.**STEP 3. Check for noise from inside the oil pump or gear box.****Q: Is there noise?****YES** : Replace the part. Then go to Step 4.**NO** : Go to Step 4**STEP 4. Check for rattling noise.**

Confirm that no noise is generated.

Q: Is there noise?**YES** : Repeat from Step 1.**NO** : Diagnosis is complete.**INSPECTION PROCEDURE 4: Shrill Noise****DIAGNOSIS****STEP 1. Check for entry of air.****Q: Has air entered?****YES** : Bleed the air (Refer to [P.37A-17](#)). Then go to Step 3.**NO** : Go to Step 2.**STEP 2. Check for seizure in the oil pump.****Q: Is there seizure?****YES** : Replace the part. Then go to Step 3.**NO** : Go to Step 3.**STEP 3. Check symptoms.**

Confirm that no noise is generated.

Q: Is there noise?**YES** : Repeat from Step 1.**NO** : Diagnosis is complete.

INSPECTION PROCEDURE 5: Squealing Noise

DIAGNOSIS

STEP 1. Check the belt tension.

Refer to GROUP 00, Maintenance Service – Drive Belts [P.00-40](#).

Q: Is the belt tension incorrect?

YES : Adjust the belt tension. (Refer to GROUP 00, Maintenance Service – Drive Belts [P.00-40](#).) Then go to Step 3.

NO : Go to Step 2.

STEP 2. Check for seizure in the oil pump.

Q: Is there seizure?

YES : Replace the part. Then go to Step 3.

NO : Go to Step 3.

STEP 3. Check symptoms.

Confirm that no noise is generated.

Q: Is there noise?

YES : Repeat from Step 1.

NO : Diagnosis is complete.

INSPECTION PROCEDURE 6: Hissing Noise

DIAGNOSIS

STEP 1. Check for entry of air.

Q: Has air entered?

YES : Bleed the air (Refer to [P.37A-17](#)). Then go to Step 4.

NO : Go to Step 2.

STEP 2. Check each hose for crushing or twisting.

Q: Is there fault?

YES : Repair or replace the hose. Then go to Step 4.

NO : Go to Step 3.

STEP 3. Check the steering gear box for damage.

Q: Is there damage?

YES : Repair or replace the part. Then go to Step 4.

NO : Go to Step 4.

STEP 4. Check symptoms.

Confirm that no noise is generated.

Q: Is there noise?

YES : Repeat from Step 1.

NO : Diagnosis is complete.

INSPECTION PROCEDURE 7: Droning Noise

DIAGNOSIS

STEP 1. Check the oil pump or oil pump bracket installation.

Q: Is the oil pump or oil pump bracket installation correct?

YES : Go to Step 2.

NO : Repair it. Then go to Step 3.

STEP 2. Check the oil pump for damage.

If a slight "beat noise" is produced by the oil pump when the steering wheel is turned fully and held in that position, this is not a malfunction.

Q: Is there damage?

YES : Replace the oil pump. Then go to Step 3.

NO : Go to Step 3.

STEP 3. Check symptoms.

Confirm that no noise is generated.

Q: Is there noise?

YES : Repeat from Step 1.

NO : Diagnosis is complete.

INSPECTION PROCEDURE 8: Squeaking Noise

DIAGNOSIS

STEP 1. Check for interference of the wheel and vehicle body.

If interfering, adjust the steering angle.

- (1) Place the front wheel on a turning radius gauge and measure the steering angle.

Standard value:
<ECLIPSE>

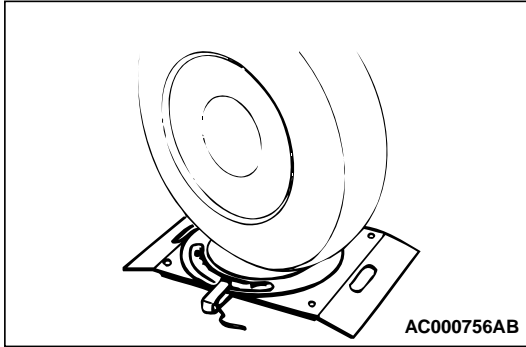

ITEMS	2.4L ENGINE	3.0L ENGINE
Inside wheel	36°12' ± 2°00'	31°00' ± 2°00'
Outside wheel (reference)	30°24'	27°00'

<ECLIPSE SPYDER>

ITEMS	2.4L ENGINE	3.0L ENGINE
Inside wheel	36°12' ± 2°00'	33°60' ± 2°00'
Outside wheel (reference)	30°24'	28°30'

- (2) If the steering angle is not within the standard value, adjust the toe-in.

Standard value: 0 ± 3 mm (0 ± 0.12 inch)

- (3) Adjust the toe-in by undoing the clip and turning the left and right tie rod turnbuckles by the same amount (in opposite directions).

NOTE: The toe will move out as the left turnbuckle is turned toward the front of the vehicle and the right turnbuckle is turned toward the rear of the vehicle.

Q: Is the steering angle normal?

YES : Go to Step 2.

NO : Adjust the steering angle. Then go to Step 3.

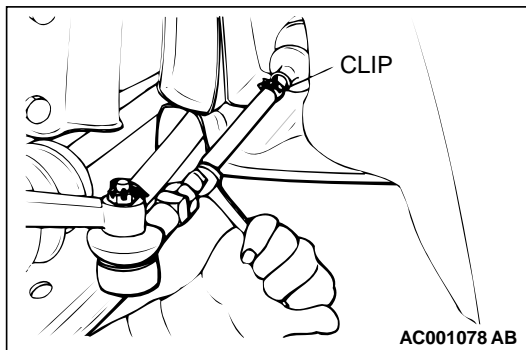

STEP 2. Check the steering gear box for damage.

Q: Is there damage?

YES : Repair or replace the part. Then go to Step 3.

NO : Go to Step 3.

STEP 3. Check symptoms.

Confirm that no noise is generated.

Q: Is there noise?

YES : Repeat from Step 1.

NO : Diagnosis is complete.

INSPECTION PROCEDURE 9: Vibration

NOTE: A slight vibration may be felt when the stationary steering effort is made due to the condition of the road surface. To check whether the vibration actually exists or not, test-drive the vehicle on a dry concrete or asphalt surface. Moreover, a very slight amount of vibration is not a malfunction.

DIAGNOSIS

STEP 1. Check for entry of air.

Q: Has air entered?

YES : Bleed the air (Refer to P.37A-17.). Then go to Step 3.

NO : Go to Step 2.

STEP 2. Check the steering gear box for damage.

Q: Is there damage?

YES : Repair or replace the part. Then go to Step 3.

NO : Go to Step 3.

STEP 3. Check symptoms.

Confirm that no noise is generated.

Q: Is there noise?

YES : Repeat from Step 1.

NO : Diagnosis is complete.

INSPECTION PROCEDURE 10: Oil Leakage from Hose Connection

DIAGNOSIS

STEP 1. Check for loosening of the flare nut.

Q: Is the flare nut loose?

YES : Tighten it to 15 ± 3 N·m (11 ± 2 ft·lb). Then go to Step 3.

NO : Go to Step 2.

STEP 2. Check the insertion of the hose and the clamp installation state.

Q: Are they correct?

YES : Go to Step 3.

NO : Repair or replace the part. Then go to Step 3.

STEP 3. Check symptoms.

Check that no oil is leaking.

Q: Is there oil leakage?

YES : Repeat from Step 1.

NO : Diagnosis is complete.

INSPECTION PROCEDURE 11: Oil Leakage from Hose Assembly

DIAGNOSIS

STEP 1. Check the hose for damage or clogging.

Q: Is the hose damaged or clogged?

YES : Repair or replace it. Then go to Step 2.

NO : Go to Step 2.

STEP 2. Check symptoms.

Check that no oil is leaking.

Q: Is there oil leakage?

YES : Repeat from Step 1.

NO : Diagnosis is complete.

INSPECTION PROCEDURE 12: Oil Leakage from Oil Reservoir

DIAGNOSIS**STEP 1. Check the oil reservoir for damage.****Q: Is there damage?****YES :** Repair or replace it. Then go to Step 3.**NO :** Go to Step 2.**STEP 2. Check for overflowing.****Q: Is there overflowing?****YES :** Adjust fluid level. Then go to Step 3.**NO :** Go to Step 3.**STEP 3. Check symptoms.****Q: Is there oil leakage?****YES :** Repeat from to Step 1.**NO :** Diagnosis is complete.**INSPECTION PROCEDURE 13: Oil Leakage from Oil Pump**

DIAGNOSIS**STEP 1. Check the oil pump body for damage.****Q: Is there damage?****YES :** Replace the part. Then go to Step 3.**NO :** Go to Step 2.**STEP 2. Check the O-ring or oil seal for damage.****Q: Is there damage?****YES :** Replace the part. Then go to Step 3.**NO :** Go to Step 3.**STEP 3. Check symptoms.**

Check that no oil is leaking.

Q: Is there oil leakage?**YES :** Repeat from Step 1.**NO :** Diagnosis is complete.**INSPECTION PROCEDURE 14: Oil Leakage from Gear Box**

DIAGNOSIS**STEP 1. Check the gear box housing for damage.****Q: Is there damage?****YES :** Replace the part. Then go to Step 3.**NO :** Go to Step 2.**STEP 2. Check the oil-ring or oil seal for damage.****Q: Is there damage?****YES :** Replace the part. Then go to Step 3.**NO :** Go to Step 3.**STEP 3. Check symptoms.**





Check that no oil is leaking.

Q: Is there oil leakage?**YES :** Repeat from Step 1.**NO :** Diagnosis is complete.

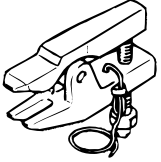
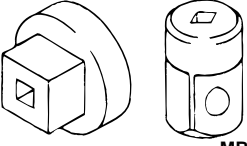
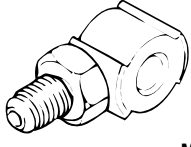
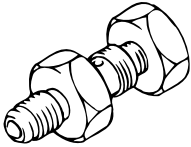
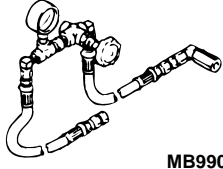
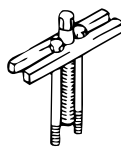
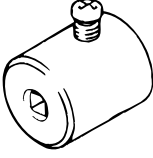
SPECIAL TOOLS

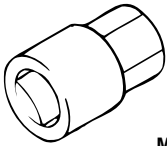
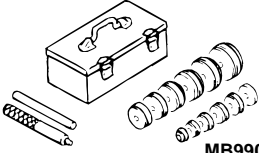
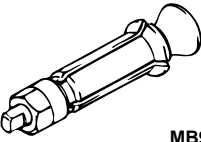
M1372000600075

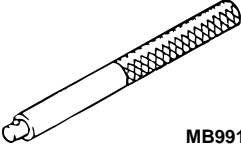
TOOL	TOOL NUMBER AND NAME	SUPERSESION	APPLICATION
 <p>MB990635</p>	<p>MB991113 or MB990635 Steering linkage puller</p>	<p>MB991113-01, MB990635-01 or general service tool</p>	<p>Tie rod end disconnection</p>
 <p>MB990326</p>	<p>MB990326 Preload socket</p>	<p>General service tool</p>	<p>Tie rod end ball joint breakaway torque check</p>
 <p>MB991548</p>	<p>MB991548 Power steering oil pressure gauge adapter (Pump side)</p>	<p>MB991548-01</p>	<p>Oil pump pressure test</p>
 <p>MB991549</p>	<p>MB991549 Power steering oil pressure gauge adapter (Hose side)</p>	<p>MB991549-01</p>	
 <p>MB990662</p>	<p>MB990662 Oil pressure gauge assembly</p>	<p>MB990662-01</p>	
 <p>MB990803</p>	<p>MB990803 Steering wheel puller</p>	<p>General service tool</p>	<p>Steering wheel removal</p>
 <p>MB991006</p>	<p>MB990228 or MB991006 Preload socket</p>	<p>MB990228-01</p>	<p>Gear box total pinion torque check</p>

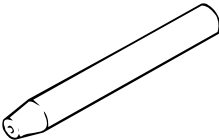
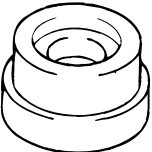
TOOL	TOOL NUMBER AND NAME	SUPERSESION	APPLICATION
 <p>MB991204</p>	MB991204 Torque wrench socket	General service tool	<ul style="list-style-type: none"> • Rack support adjustment • Rack support cover removal
 <p>MB990925</p>	MB990925 Bearing and oil seal installer set	MB990925-01 or general service tool	<ul style="list-style-type: none"> • Oil seal and bearing installation • MB990926, MB990927, MB990938, MB990939 (For details, refer to GROUP 26, Special Tools P.26-4.)
 <p>MB991120</p>	MB991120 Needle bearing puller	Tool not available	Needle roller bearing removal
 <p>MB991199</p>	MB991199 Oil seal installer	General service tool	Oil seal installation
 <p>MB991197</p>	MB991197 Bar (long type)	General service tool	
 <p>MB991202</p>	MB991202 Oil seal and bearing installer	General service tool	Needle roller bearing installation
 <p>MB991212</p>	MB991213 Rack installer	General service tool	Rack installation
 <p>MB991203</p>	MB991203 Oil seal and bearing installer	Tool not available	Oil seal and bearing installation

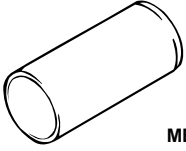
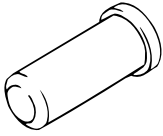
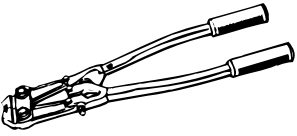
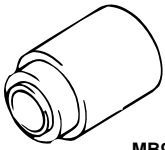
TOOL	TOOL NUMBER AND NAME	SUPERSESSION	APPLICATION
 MB991317	MB991317 Seal ring installer	Tool not available	Seal ring installation
 MB991152	MB991152 Dust cover installer	General service tool	Oil seal installation
 MB991561	MB991561 Boot band crimping tool	–	Bellows band installation
 MB990776	MB990776 Front axle base	MB990776-01	Dust cover installation

ON-VEHICLE SERVICE

STEERING WHEEL FREE PLAY CHECK

M1372001000076

1. With the engine running (hydraulic operation), set the front wheels straight ahead.
2. Measure the play on the steering wheel circumference before the wheels start to move when slightly moving the steering wheel in both directions.

Limit: 30 mm (1.2 inch)

3. When the play exceeds the limit, check for the play on the steering shaft and steering linkage connection. Correct or replace.
4. If the free play still exceeds the limit value, set the steering wheel straight ahead with the engine stopped. Load 5 N (1.1 pound) towards the steering wheel circumference and check the play.

Standard value (steering wheel play with the engine stopped): 10 mm (0.4 inch) or less

5. If the play exceeds the standard value, remove the steering gear box (Refer to [P.37A-23.](#)) and check total pinion torque (Refer to [P.37A-25.](#)).

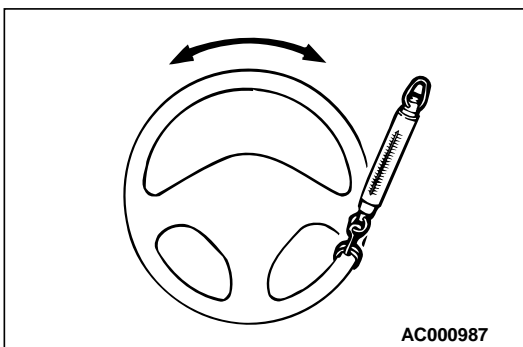

STEERING ANGLE CHECK

M1372001100073

1. Place the front wheel on a turning radius gauge and measure the steering angle.

Standard value:

<ECLIPSE>

ITEMS	2.4L ENGINE	3.0L ENGINE
Inside wheel	36°12' ± 2°00'	31°00' ± 2°00'
Outside wheel (reference)	30°24'	27°00'

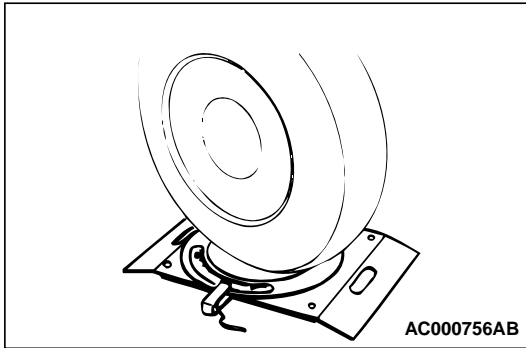

<ECLIPSE SPYDER>

ITEMS	2.4L ENGINE	3.0L ENGINE
Inside wheel	36°12' ± 2°00'	33°60' ± 2°00'
Outside wheel (reference)	30°24'	28°30'

2. If the steering angle is not within the standard value, adjust the toe-in.

Standard value: 0 ± 3 mm (0 ± 0.12 inch)

3. Adjust the toe-in by undoing the clip and turning the left and right tie rod turnbuckles by the same amount (in opposite directions).

NOTE: The toe will move out as the left turnbuckle is turned toward the front of the vehicle and the right turnbuckle is turned toward the rear of the vehicle.

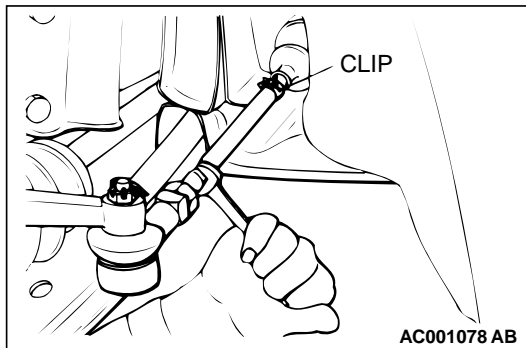
TIE ROD END BALL JOINT BREAKAWAY
TORQUE CHECK

M1372001500071

Required Special Tools:

- MB990326: Preload Socket
- MB991113 or MB990635: Steering Linkage Puller

CAUTION

- Loosen the nut from the ball joint instead of removing it.
- Hang special tool MB991113 or MB990635 with ropes to prevent it from falling.

1. Use special tool MB991113 or MB990635 to disconnect the ball joint.

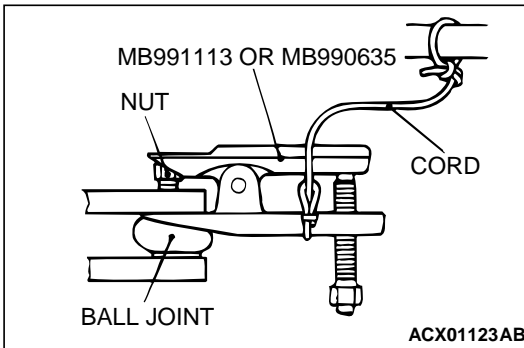

2. Move the ball joint stud several times and install the nut on the stud. Measure the ball joint breakaway torque with special tool MB990326.

Standard value: 0.5 – 2.5 N·m (4.4 – 22.1 in-lb)

3. If the breakaway torque exceeds the standard value, replace the tie rod end.

4. If the breakaway torque is under the standard value, check the ball joint for end play or ratcheting. If no end play or ratcheting, the ball joint can be re-used.

5. Tighten the nut to the specified torque and install a new cotter pin.

Tightening torque: 29 ± 4 N·m (21 ± 4 ft-lb)

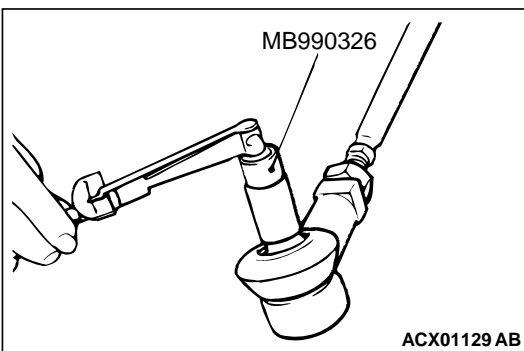

STATIONARY STEERING EFFORT CHECK

M1372001700075

1. With the vehicle stopped on a flat and paved surface, turn the steering wheel to the straight ahead position.

2. Start the engine and check the engine idle speed.

Standard value:

ENGINE	ENGINE IDLE SPEED r/min
2.4L Engine	750 ± 100
3.0L Engine	700 ± 100

3. Attach a spring scale to the outer circumference of the steering wheel and measure the steering force required to turn the steering wheel from the straight ahead position to the left and right (within a range of 1.5 turns). Also check to be sure that there is no significant fluctuation of the required steering effort.

Standard value:

Steering effort: 30 N (6.7 lb) or less

Fluctuation allowance: 5.9 N (1.33 lb) or less

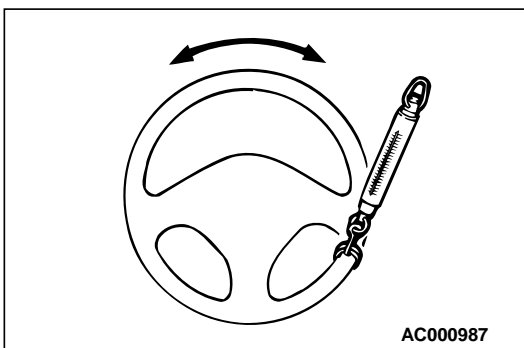

STEERING WHEEL RETURN TO CENTER CHECK

M1372001800072

Conduct a road test:

1. Make both gradual and sudden turns and check the steering wheel return.
2. At a speed of approximately 35 km/h (22 mph), turn the steering wheel 90 degrees, hold a few seconds, then release. If the steering wheel then returns 70 degrees or more, the return can be judged satisfactory.

NOTE: There will be a momentary feeling or "heaviness" when the wheel is turned quickly, but this is not abnormal. (Oil pump discharge amount is especially apt to be insufficient during idling.)

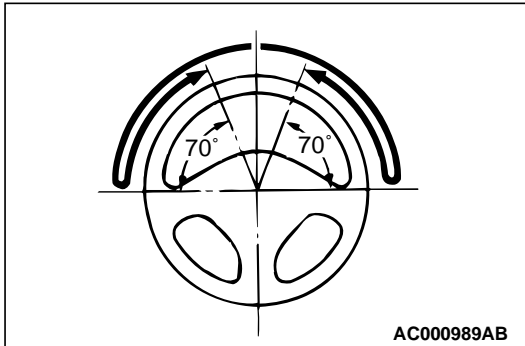
**DRIVE BELT TENSION CHECK**

M1372001900079

Refer to GROUP 00, Maintenance Service – Drive Belts P.00-40.

FLUID LEVEL CHECK

M1372002000079

1. Park the vehicle on a flat, level surface, start the engine, and then turn the steering wheel several times to raise the temperature of the fluid to approximately 50 – 60°C (122 – 140°F).
2. With the engine running, turn the wheel all the way to the left and right several times.
3. Check the fluid in the oil reservoir for foaming or milkiness. Check the difference of the fluid level when the engine is stopped, and while it is running. If the change of the fluid level is 5 mm (0.2 inch) or more, air bleeding should be done.

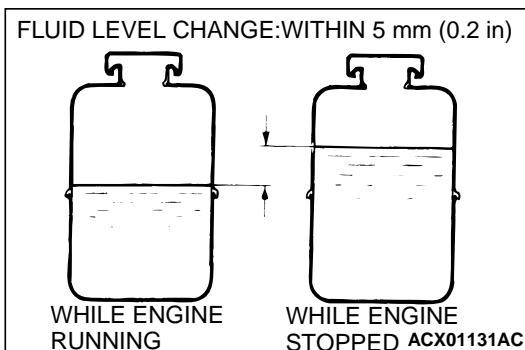
**FLUID REPLACEMENT**

M1372002100076

1. Raise and support the front wheels.
2. Disconnect the return hose connection.
3. Connect a vinyl hose to the return hose, and drain the fluid into a container.

⚠ CAUTION

Be careful not to position the high-tension cable near the fuel rail.

4. Disconnect the high-tension cable.
5. While operating the starter motor intermittently, turn the steering wheel all the way to the left and right several times to drain all of the fluid.
6. Connect the return hose securely, and then secure with the clip.
7. Fill the oil reservoir with MITSUBISHI POWER STEERING FLUID up to the lower position of the filler, and then bleed the air.

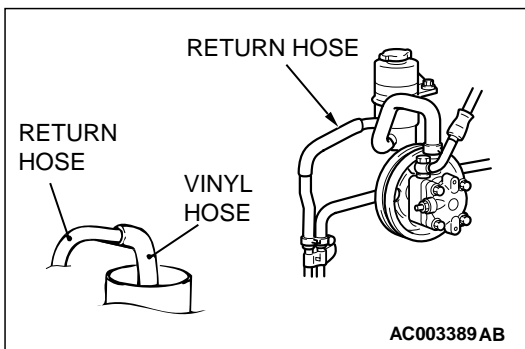

POWER STEERING SYSTEM BLEEDING

M1372002200084

Perform air bleeding procedure as necessary after replacing the steering gear box or the steering fluid lines.

1. Raise and support the front wheels.
2. Disconnect the high-tension cable. Turn the steering wheel all the way to the left and right five or six times while using the starter motor to crank the engine intermittently several times (for 15 to 20 seconds).

⚠ CAUTION

- Be careful not to place the high-tension cable near the fuel rail.
 - Perform air bleeding only while cranking the engine. If air bleeding is performed while the engine is running, air could enter the fluid. During air bleeding, refill the steering fluid supply so that the level never falls below the lower mark on the dipstick.
3. Connect the high-tension cable. Start the engine (idling).
 4. Turn the steering wheel to the left and right until there are no air bubbles in the oil reservoir.
 5. Confirm that the fluid is not milky, and that the level is between the high and low dipstick marks.
 6. Confirm that there is very little change in the fluid level when the steering wheel is turned left and right.
 7. Confirm that the change in the fluid level is no more than 5 mm (0.2 inch) when the engine is stopped and when it is running.

⚠ CAUTION

If the fluid level rises suddenly after the engine is stopped, the air has not been completely bled. If air bleeding is not complete, there will be abnormal noises from the pump and the flow-control valve, and this condition could cause reduce the life of the power steering components.

8. If the change of the fluid level is 5 mm (0.2 inch) or more, the air has not been completely bled from the system. Air bleeding procedure must be repeated.

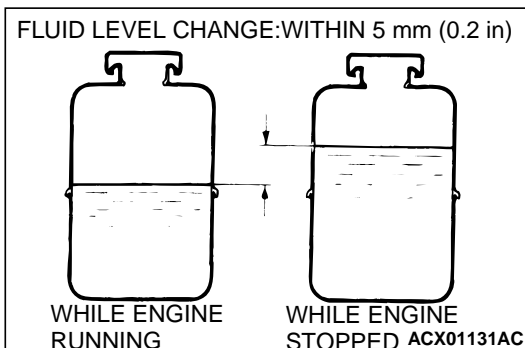

OIL PUMP PRESSURE TEST

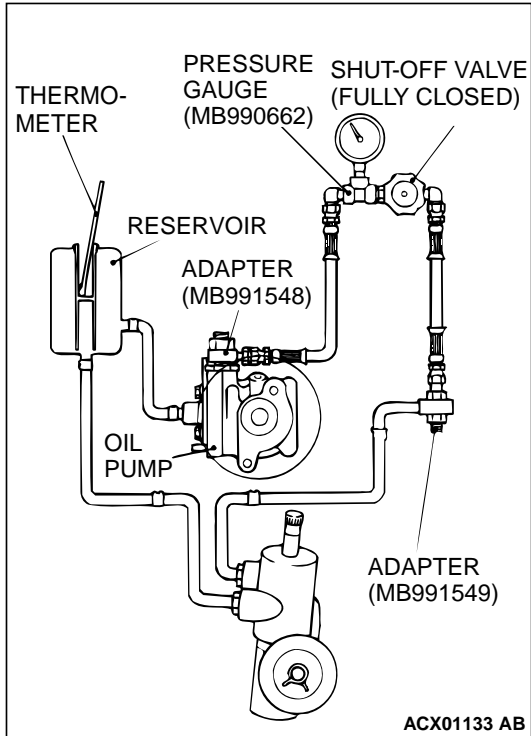

Required Special Tools:

- MB990662: Pressure Gauge
- MB991548: Power Steering Oil Pressure Gauge Adapter (Pump Side)
- MB991549: Power Steering Oil Pressure Gauge Adapter (Hose Side)

1. Disconnect the pressure hose from the oil pump, and then connect special tools MB991548, MB990662 and MB991549.
2. Bleed air, then turn the steering wheel several times while the vehicle is not moving so that the temperature of the fluid rises to approximately 50 – 60°C (122 – 140°F).
3. Start the engine and idle it at $1,000 \pm 100$ r/min.

⚠ CAUTION

The pressure gauge shut-off valve must not remain closed for more than 10 seconds.

4. Fully close the shut-off valve of the pressure gauge and measure the oil pump relief pressure to confirm that it is within the standard value range. Open it again immediately after checking the pressure.

Standard value: 8.3 – 9.5 MPa (1,209 – 1,280 psi)

5. If it is not within the standard value, replace the oil pump.
6. Check whether or not the hydraulic pressure is the standard value when no-load conditions are created by fully opening the shut-off valve of the pressure gauge.

Standard value: 0.8 – 1.0 MPa (116 – 145 psi)

7. If it is not within the standard value, the probable cause is a malfunction of the oil line or steering gear box, so check these parts and repair as necessary.
8. Turn the steering wheel all the way to the left or right; then check whether or not the retention hydraulic pressure is the standard value.

Standard value: 8.3 – 9.5 MPa (1,209 – 1,280 psi)

9. If not the standard value, overhaul the steering gear box. Remeasure fluid pressure.
10. Remove special tools MB991548, MB990662 and MB991549, and then tighten the pressure hose to the specified torque.

Tightening torque: 57 ± 7 N·m (42 ± 5 ft-lb)

11. Bleed the system.

POWER STEERING PRESSURE SWITCH CHECK

M1372007200078

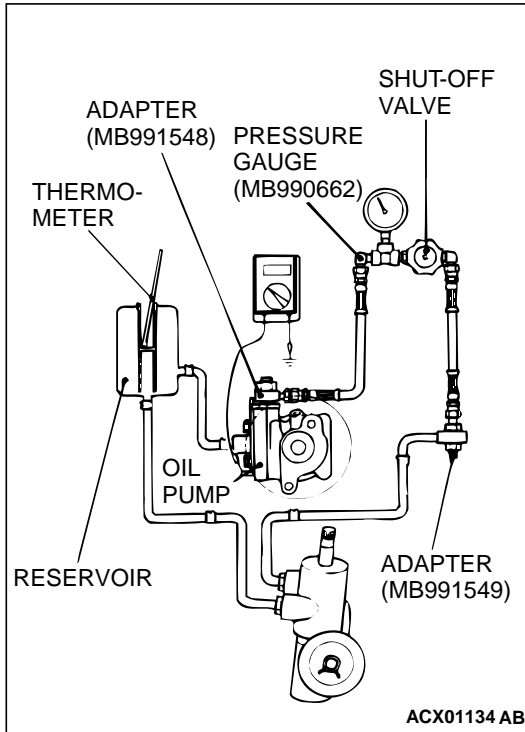

Required Special Tools:

- MB990662: Pressure Gauge
- MB991548: Power Steering Oil Pressure Gauge Adapter (Pump Side)
- MB991549: Power Steering Oil Pressure Gauge Adapter (Hose Side)

1. Disconnect the pressure hose from the oil pump, and then connect special tools MB991548, MB990662 and MB991549.
2. Bleed air, and then turn the steering wheel several times while the vehicle is not moving so that the temperature of the fluid rises to approximately 50 – 60°C (122 – 140°F).
3. The engine should be idling.
4. Disconnect the connector for the oil pressure switch, and place an ohmmeter.
5. Gradually close the shut-off valve of the pressure gauge and increase the hydraulic pressure, then check whether or not the hydraulic pressure that activates the switch is the standard value.

Standard value: 1.8 – 2.4 MPa (261 – 348 psi)

6. Gradually open the shut-off valve and reduce the hydraulic pressure; then check whether or not the hydraulic pressure that deactivates the switch is the standard value.

Standard value: 0.8 – 2.4 MPa (116 – 348 psi)

7. Remove special tools MB991548, MB990662 and MB991549, and then tighten the pressure hose to the specified torque.

Tightening torque: 57 ± 7 N·m (42 ± 5 ft-lb)

8. Bleed the system.

BALL JOINT DUST COVER CHECK

M1372008600079

1. Press the dust cover with your finger to check whether the dust cover is cracked or damaged.
2. If the dust cover is cracked or damaged, replace the tie rod end.

NOTE: If the dust cover is cracked or damaged, the ball joint could be damaged.

STEERING WHEEL AND SHAFT ASSEMBLY

REMOVAL AND INSTALLATION

M1372002600071

WARNING

- Before removing the air bag module, refer to **GROUP 52B, Service Precautions and Air Bag Module and Clock Spring P.52B-15.**
- When removing and installing the steering wheel, do not let it bump against the air bag module.

Post-installation Operation

- Checking Steering Wheel Position with Wheels Straight Ahead

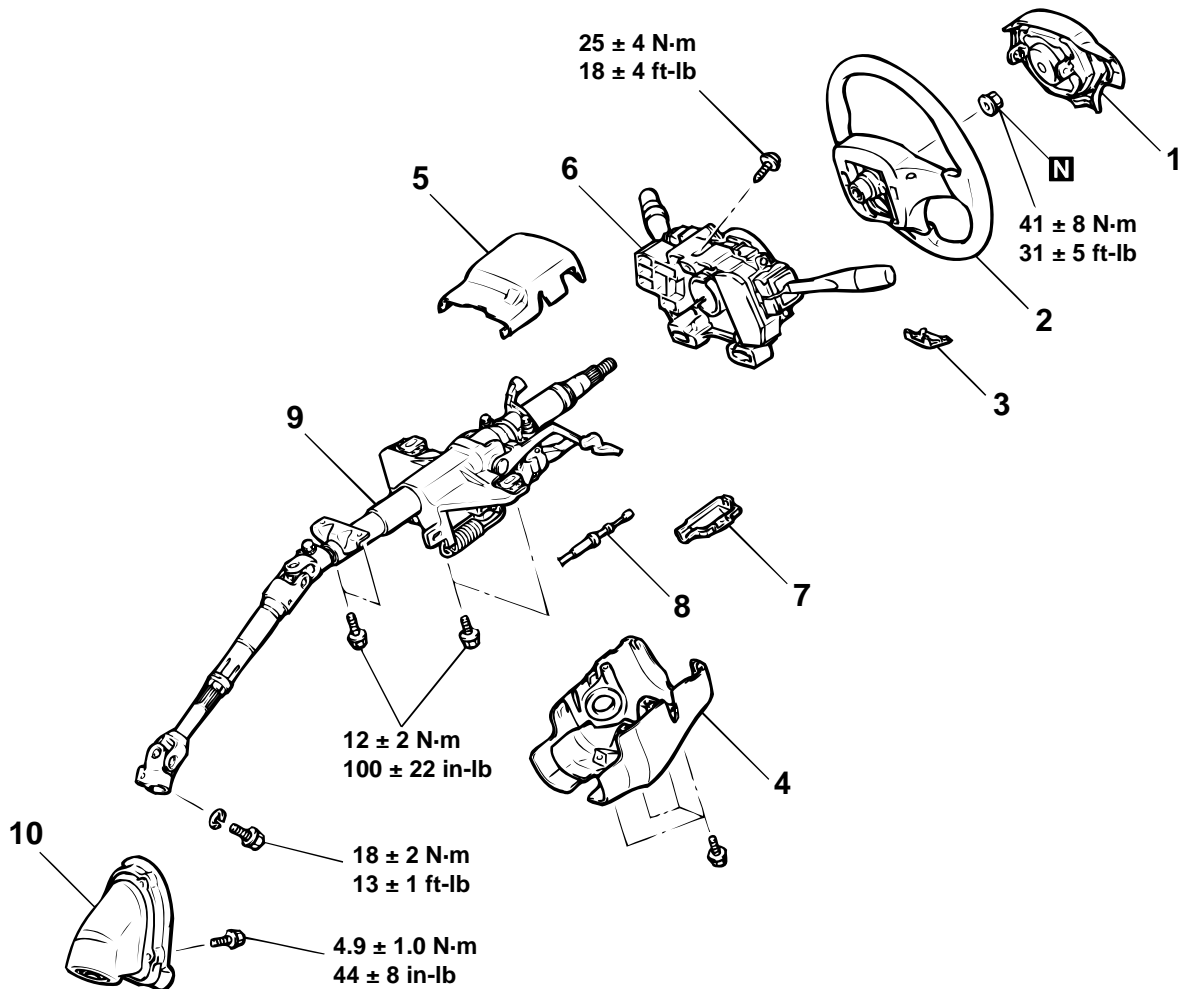

AC000990AC

REMOVAL STEPS

1. AIR BAG MODULE (REFER TO GROUP 52B, AIR BAG MODULE AND CLOCK SPRING P.52B-69.)
2. STEERING WHEEL
3. COVER
 - INSTRUMENT PANEL UNDER COVER (REFER TO GROUP 52A, INSTRUMENT PANEL P.52A-4.)
4. LOWER COLUMN COVER
5. UPPER COLUMN COVER

REMOVAL STEPS (Continued)

6. CLOCK SPRING AND COLUMN SWITCH ASSEMBLY (REFER TO GROUP 52B, AIR BAG MODULE AND CLOCK SPRING P.52B-69.)
7. COVER <A/T>
8. KEY INTERLOCK CABLE <A/T>
9. STEERING SHAFT ASSEMBLY
10. STEERING COVER ASSEMBLY

Required Special Tool:

- MB990803:Steering Wheel Puller

<<A>>

TSB Revision

REMOVAL SERVICE POINT

<<A>> STEERING WHEEL REMOVAL

⚠ CAUTION

Do not hammer on the steering wheel to remove it; doing so will damage the collapsible mechanism.
Use special tool MB990803 to remove the steering wheel.

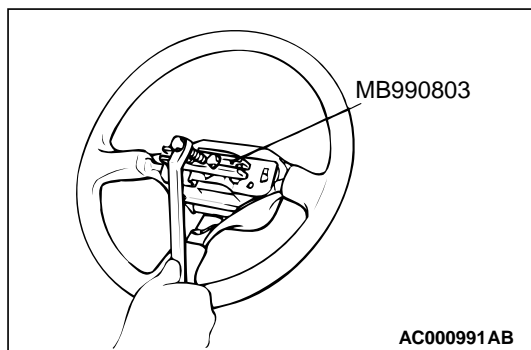

DISASSEMBLY AND ASSEMBLY

M1372002800075

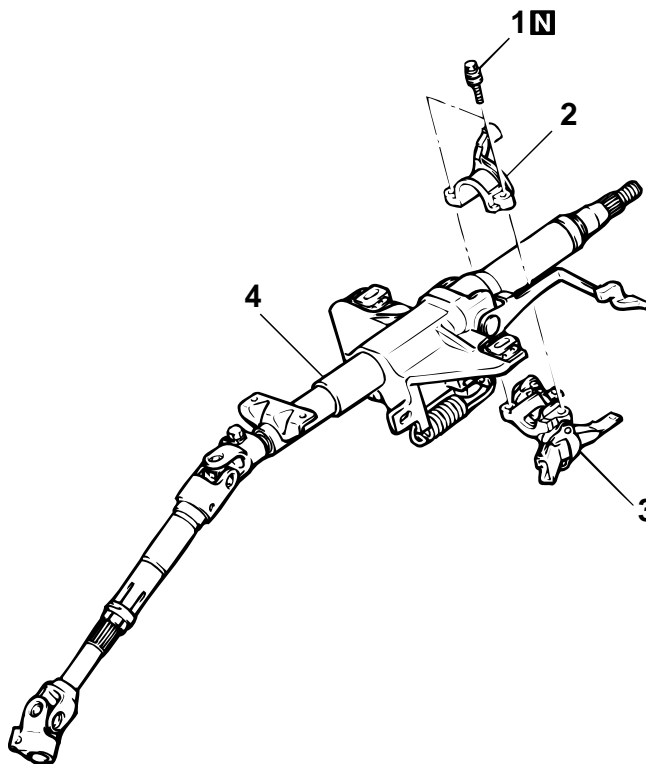

AC000992 AB

- DISASSEMBLY STEPS**
- >>A<< 1. SPECIAL BOLT
 - <<A>> >>A<< 2. STEERING LOCK BRACKET

- DISASSEMBLY STEPS (Continued)**
- <<A>> >>A<< 3. STEERING LOCK CYLINDER
 - 4. STEERING COLUMN ASSEMBLY

DISASSEMBLY SERVICE POINT**<<A>> STEERING LOCK BRACKET/STEERING LOCK CYLINDER REMOVAL**

If it is necessary to remove the steering lock cylinder, use a hacksaw to cut the special bolts at the steering lock bracket side.

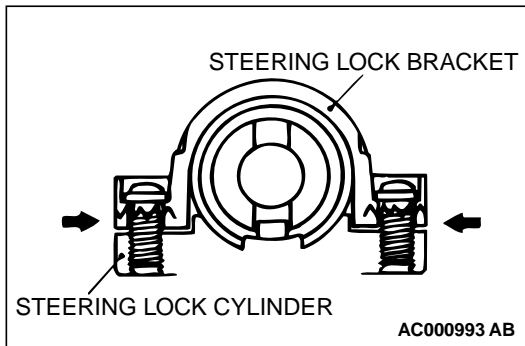
**ASSEMBLY SERVICE POINT****>>A<< STEERING LOCK CYLINDER/STEERING LOCK BRACKET/SPECIAL BOLT INSTALLATION****⚠ CAUTION**

The steering lock bracket and bolts must be replaced with new ones when the steering lock is installed.

1. When installing the steering lock cylinder and steering lock bracket to the column tube, temporarily install the steering lock in alignment with the column boss.
2. After checking that the lock works properly, tighten the special bolts until the head twists off.

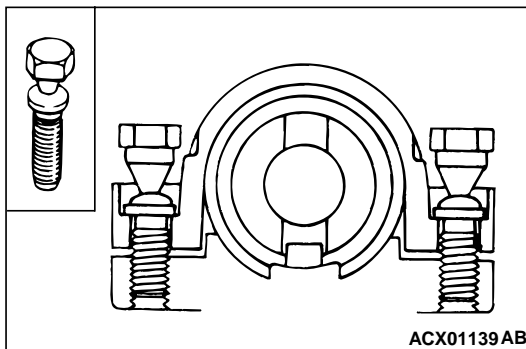

POWER STEERING GEAR BOX ASSEMBLY

REMOVAL AND INSTALLATION

M1372003900075

⚠ WARNING

Before removing the steering gear box, refer to GROUP 52B. Center the front wheels and remove the ignition key. Failure to do so may damage the SRS clock spring and render the SRS system inoperative, risking serious injury.

Pre-removal Operation

- Power Steering Fluid Draining (Refer to P.37A-16.)
- Center Member Removal (Refer to GROUP 32, Engine Roll Stopper, Centermember P.32-9.)
- Front Exhaust Pipe Removal (2.4L Engine: Refer to GROUP 15, Exhaust Pipe and Main Muffler P.15-19, 3.0L Engine: Refer to GROUP 15, Exhaust Pipe and Main Muffler P.15-21.)
- Stabilizer Bar Removal <2.4L Engine> (Refer to GROUP 33A, Stabilizer Bar P.33A-17.)

Post-installation Operation

- Check the Dust Cover for Cracks or Damage by Pushing it with Finger.
- Stabilizer Bar Installation <2.4L Engine> (Refer to GROUP 33A, Stabilizer Bar P.33A-17.)
- Front Exhaust Pipe Installation (2.4L Engine: Refer to GROUP 15, Exhaust Pipe and Main Muffler P.15-19, 3.0L Engine: Refer to GROUP 15, Exhaust Pipe and Main Muffler P.15-21.)
- Center Member Installation (Refer to GROUP 32, Engine Roll Stopper, Centermember P.32-9.)
- Power Steering Fluid Supplying (Refer to P.37A-16.)
- Power Steering Fluid Line Bleeding (Refer to P.37A-17.)
- Checking Steering Wheel Position with Wheels Straight Ahead.
- Front Wheel Alignment Adjustment (Refer to GROUP 33A, On-vehicle Service – Front Wheel Alignment Check and Adjustment P.33A-6.)

<2.4L ENGINE>

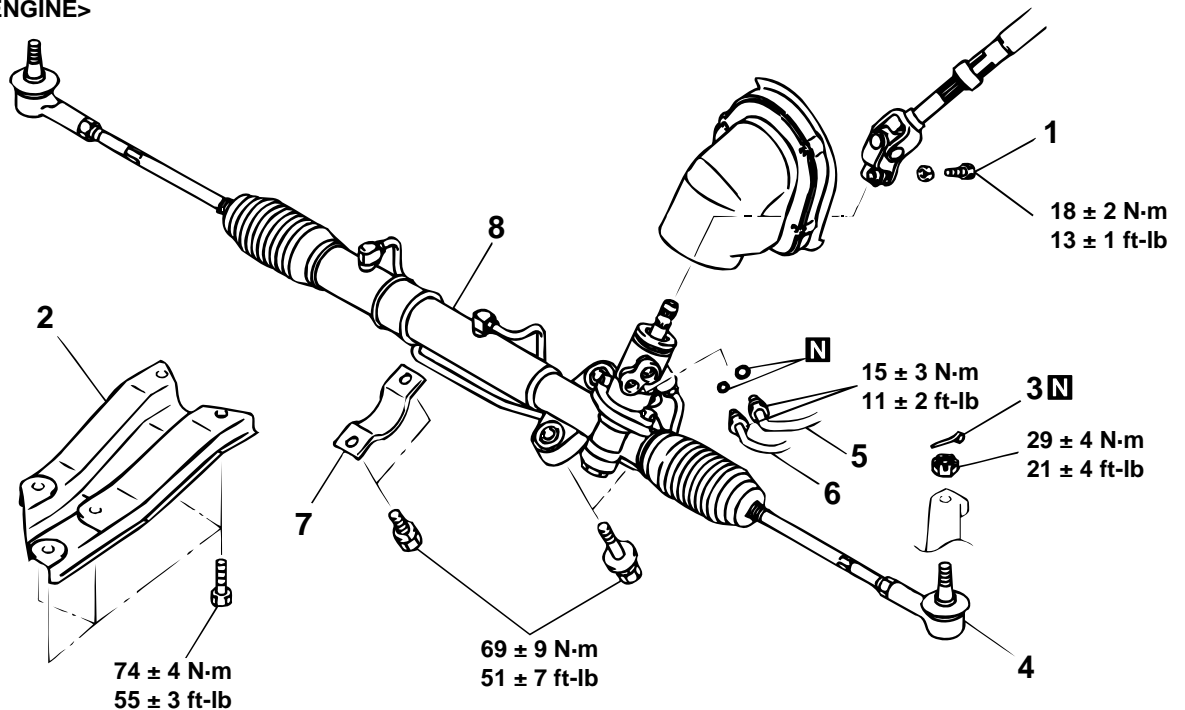

AC000994AD

<3.0L ENGINE>

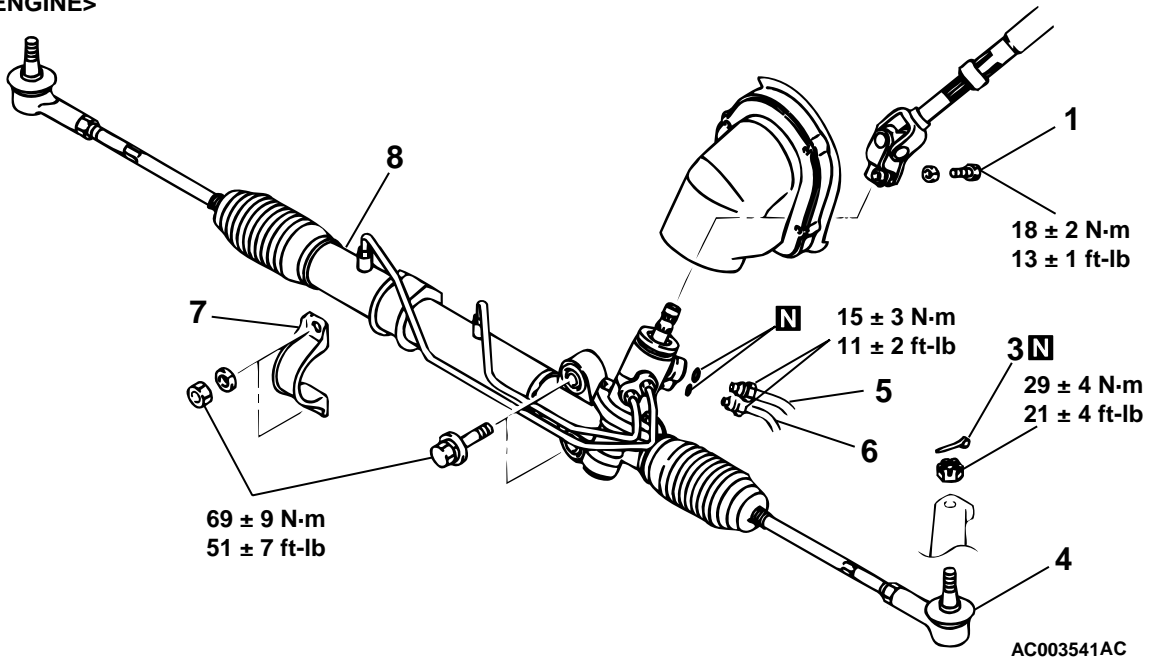

REMOVAL STEPS

1. STEERING SHAFT ASSEMBLY AND GEAR BOX CONNECTING BOLT
2. STAY <2.4L ENGINE>
3. COTTER PIN
4. TIE ROD END AND KNUCKLE CONNECTION
5. RETURN HOSE CONNECTION
6. PRESSURE TUBE CONNECTION

<<A>>

REMOVAL STEPS (Continued)

7. CYLINDER CLAMP
8. GEAR BOX ASSEMBLY

<>

Required Special Tools:

- MB990228 or MB991006: Preload Socket
- MB991113 or MB990635: Steering Linkage Puller

REMOVAL SERVICE POINTS

<<A>> TIE ROD END DISCONNECTION

CAUTION

- Loosen the nut from the ball joint instead of removing it.
- Hang special tool MB991113 or MB990635 with ropes to prevent it from falling.

Use special tool MB991113 or MB990635 to disconnect the ball joint.

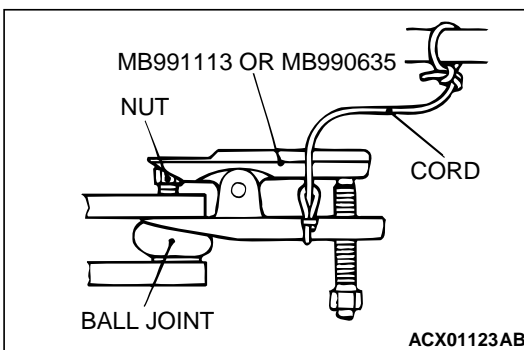

<> GEAR BOX ASSEMBLY REMOVAL

CAUTION

Be sure not to damage the bellows and the tie rod end dust cover when removing the gear box assembly.

INSPECTION

GEAR BOX TOTAL PINION TORQUE CHECK

⚠ CAUTION

When holding the steering gear box assembly in a vice, secure its mounting positions. If it is secured in any other places, the gear housing may become deformed or damaged.

Using special tool MB990228 or MB991006, rotate the pinion gear at the rate of one rotation in approximately 4 to 6 seconds to check the total pinion torque.

Standard value: 0.8 – 1.9 N·m (6.9 – 16.5 in-lb)
[Change in torque: 0.7 N·m (6.1 in-lb) or less]

NOTE: When measuring, remove the bellows from the rack housing. Measure the pinion torque through the whole stroke of the rack.

If the measured value is not within the standard range, first adjust the rack support cover, and then check the total pinion torque again.

If the total pinion torque cannot be adjusted to within the standard range by adjusting the rack support cover, check the rack support cover, rack support spring, rack support and replace any parts if necessary.

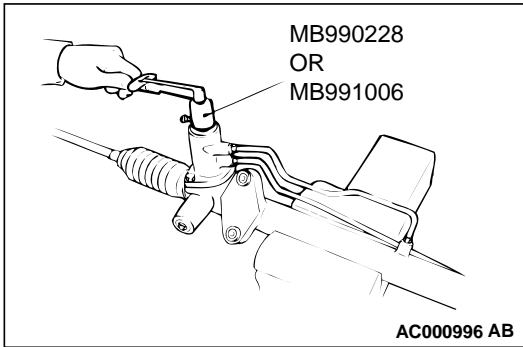

TIE ROD SWING RESISTANCE CHECK

1. Give 10 hard swings to the tie rod.
2. Measure the tie rod swing resistance with a spring scale.

Standard value: 4.0 – 18.6 N (17.8 – 82.7 lb) [1.0 – 4.9 N·m (8.7 – 43.4 in-lb)]

3. If the measured value exceeds the standard value, replace tie rod.
4. If the measured value is below the standard value, the tie rod can be re-used if it swings smoothly without excessive play.

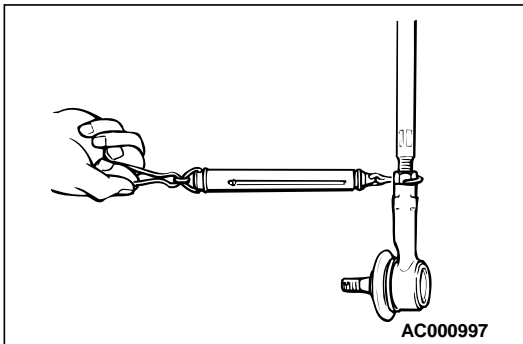

TIE ROD END BALL JOINT DUST COVER CHECK

1. Check the dust cover for cracks or damage by pushing it with your finger.
2. If the dust cover is cracked or damaged, replace the tie rod end. (Refer to [P.37A-26.](#))

NOTE: Cracks or damage of the dust cover may damage the ball joint. If it is damaged during service work, replace the dust cover. (Refer to [P.37A-36.](#))

DISASSEMBLY AND ASSEMBLY

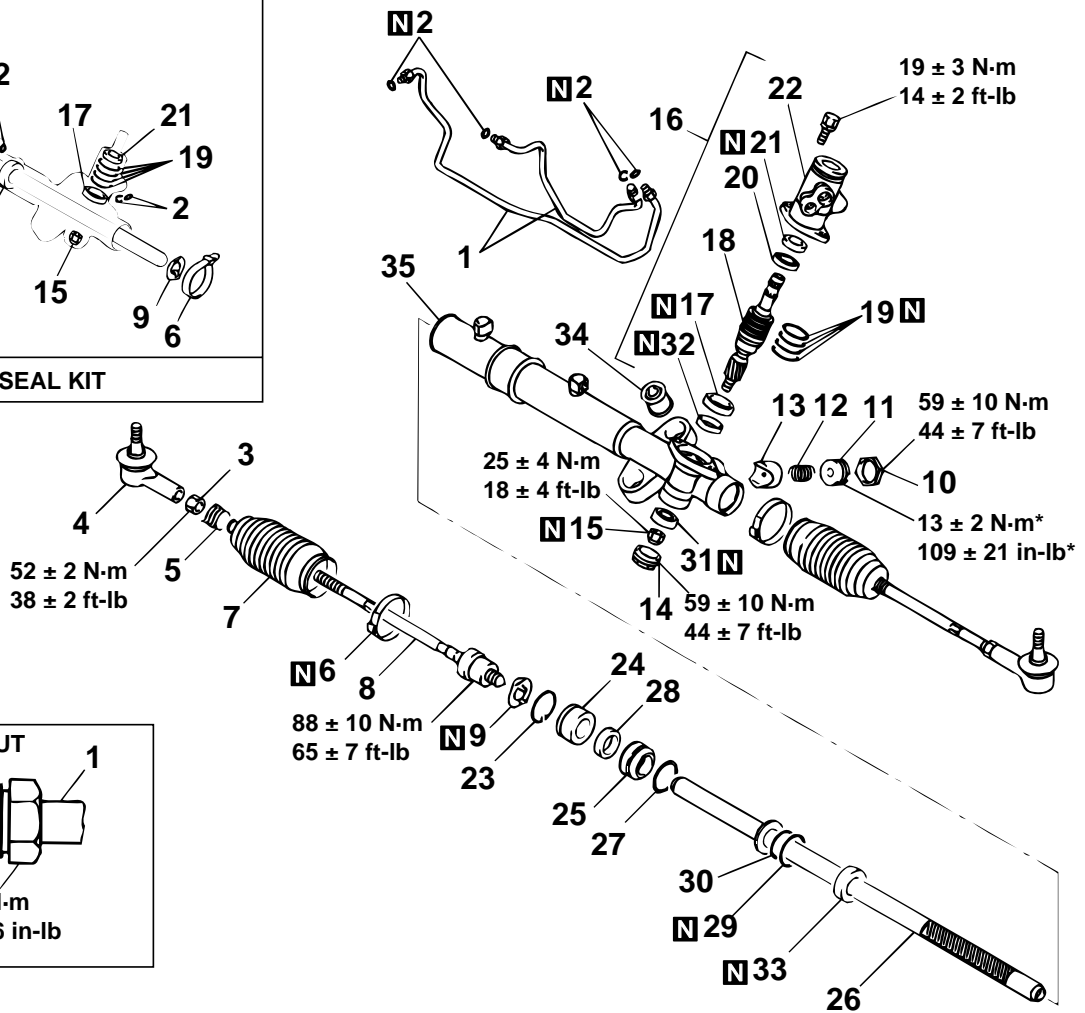
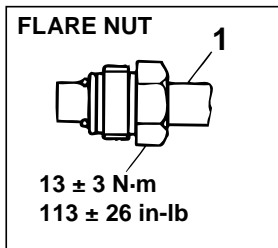
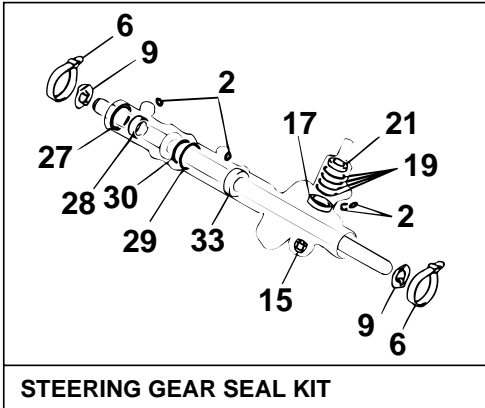

NOTE
*: Return the rack support cover -10°.

AC000999AB

DISASSEMBLY STEPS

- 1. FEED TUBE
- 2. O-RING
- >>0<< 3. TIE ROD END JAM NUT
- >>0<< 4. TIE ROD END
- 5. BELLOWS CLIP
- >>N<< 6. BELLOWS BAND
- 7. BELLOWS
- <<A>> >>M<< 8. TIE ROD
- <<A>> >>M<< 9. TAB WASHER
- >>L<< • TOTAL PINION TORQUE ADJUSTMENT
- >>K<< 10. JAM NUT
- <> >>K<< 11. RACK SUPPORT COVER
- 12. RACK SUPPORT SPRING
- 13. RACK SUPPORT
- >>J<< 14. END PLUG
- 15. JAM NUT
- 16. VALVE HOUSING ASSEMBLY
- <<C>> >>I<< 17. OIL SEAL

DISASSEMBLY STEPS (Continued)

- <<C>> 18. PINION AND VALVE ASSEMBLY
- <<D>> >>H<< 19. SEAL RING
- <<E>> >>G<< 20. BALL BEARING
- <<E>> >>G<< 21. OIL SEAL
- <<F>> >>F<< 22. VALVE HOUSING
- 23. CIRCLIP
- >>E<< 24. RACK STOPPER
- <<G>> >>D<< 25. RACK BUSHING
- >>C<< 26. RACK
- <<H>> >>C<< 27. O-RING
- 28. OIL SEAL
- 29. SEAL RING
- 30. O-RING
- <<I>> >>B<< 31. BALL BEARING
- <<J>> >>B<< 32. NEEDLE ROLLER BEARING
- <<K>> >>A<< 33. OIL SEAL
- 34. BUSHING
- 35. RACK HOUSING

Required Special Tools:

- MB990228 or MB991006: Preload Socket
- MB990776: Front Axle Base
- MB990927: Installer Adapter
- MB990938: Bar (Snap-in type)
- MB990939: Brass Bar
- MB991120: Needle Bearing Puller
- MB991152: Dust Cover Installer
- MB991197: Bar (Long type)
- MB991199: Oil Seal Installer
- MB991202: Oil Seal and Bearing Installer
- MB991203: Oil Seal and Bearing Installer
- MB991204: Torque Wrench Socket
- MB991213: Rack Installer
- MB991317: Seal Ring Installer

LUBRICATION AND SEALING POINTS

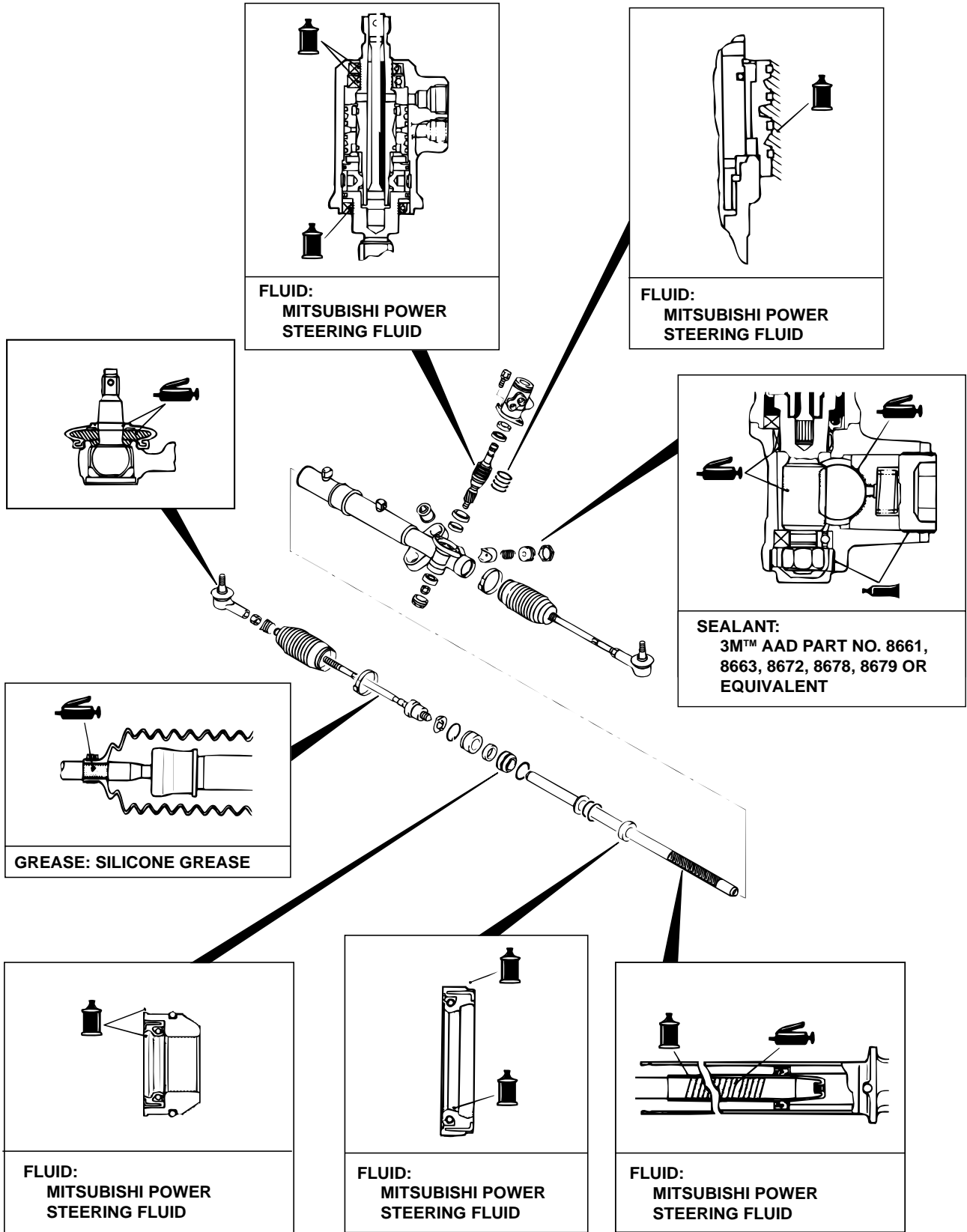

AC003542 AB

TSB Revision

DISASSEMBLY SERVICE POINTS

<<A>> TIE ROD/TAB WASHER REMOVAL

Unstake the tab washer which secures the tie rod and rack with a chisel.

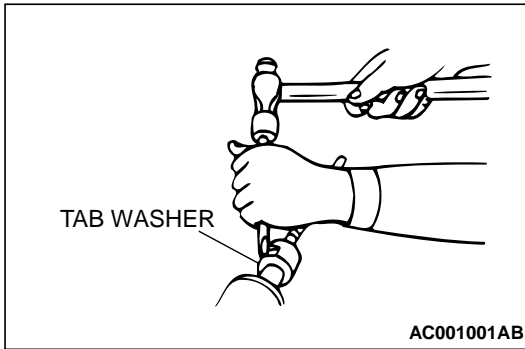

<> RACK SUPPORT COVER REMOVAL

Using special tool MB991204, remove the rack support cover from the gear box.

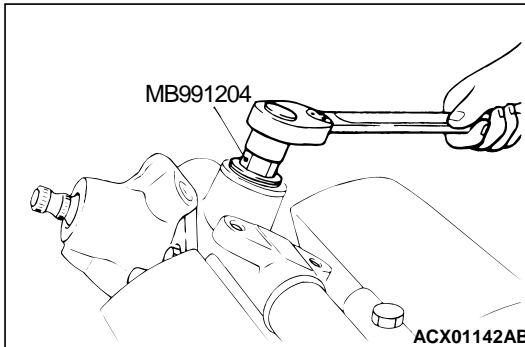

<<C>> OIL SEAL/PINION AND VALVE ASSEMBLY REMOVAL

Using a plastic hammer, gently tap the pinion to remove it.

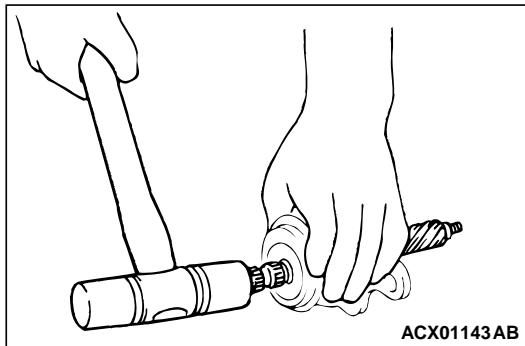

<<D>> SEAL RING REMOVAL

⚠ CAUTION

When cutting the seal ring, be careful not to damage the pinion and valve assembly or the rack.

Cut the seal ring and remove it from the pinion and valve assembly and the rack.

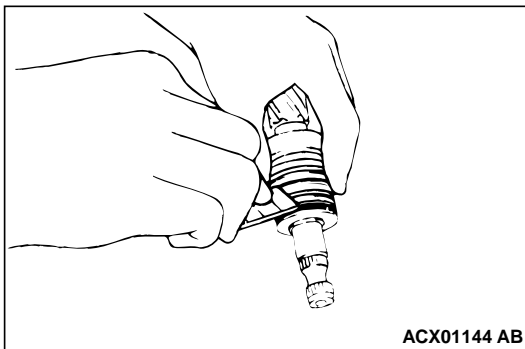

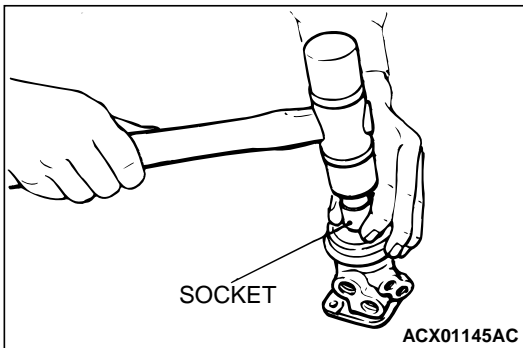
**<<E>> BALL BEARING/OIL SEAL REMOVAL**

Using a socket, remove the oil seal and the ball bearing from the valve housing simultaneously.

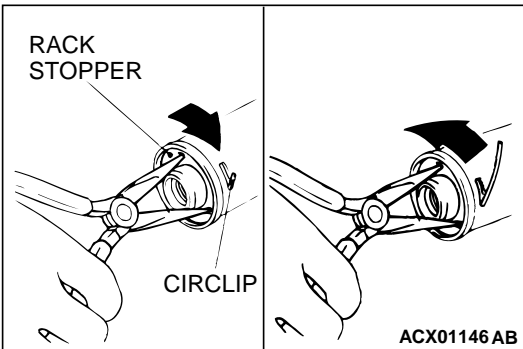
**<<F>> CIRCLIP REMOVAL****⚠ CAUTION**

If the rack stopper is first turned counterclockwise, the circlip will get caught in the slot in the housing and the rack stopper will not turn.

1. Turn the rack stopper clockwise until the end of the circlip comes out of the slot in the rack housing.
2. Turn the rack stopper counterclockwise to remove the circlip.

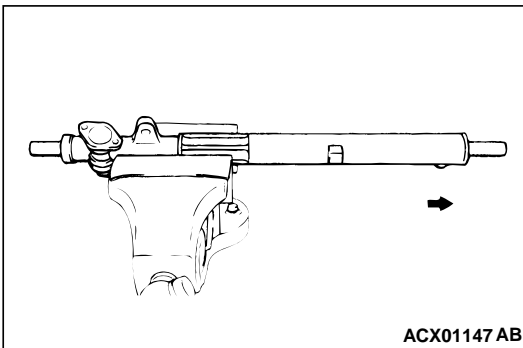
**<<G>> RACK REMOVAL**

Pull out the rack slowly. At this time also take out the rack stopper and the rack bushing simultaneously.

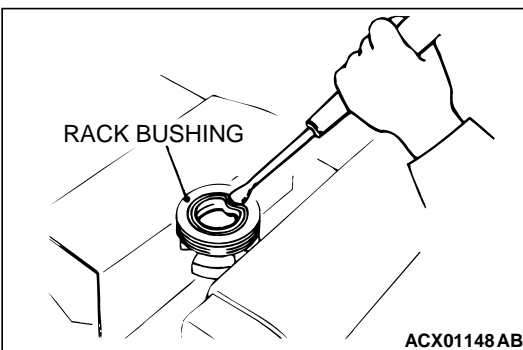
**<<H>> OIL SEAL REMOVAL****⚠ CAUTION**

Do not damage oil seal press fitting surface.

Partially bend oil seal and remove from rack bushing.

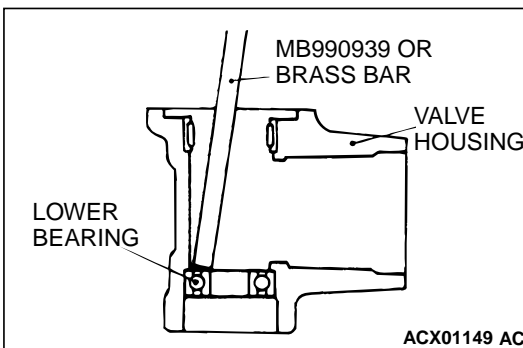
**<<I>> BALL BEARING REMOVAL**

Use a brass bar or special tool MB990939 to remove the ball bearing from the gear housing.

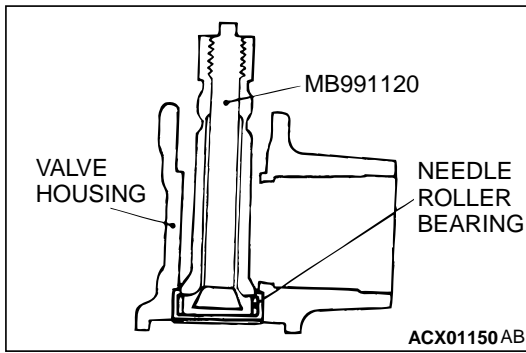

<<J>> NEEDLE ROLLER BEARING REMOVAL

CAUTION

Do not open special tool MB991120 excessively to prevent damaging housing interior.

Use special tool MB991120 to remove the needle roller bearing from the rack housing.

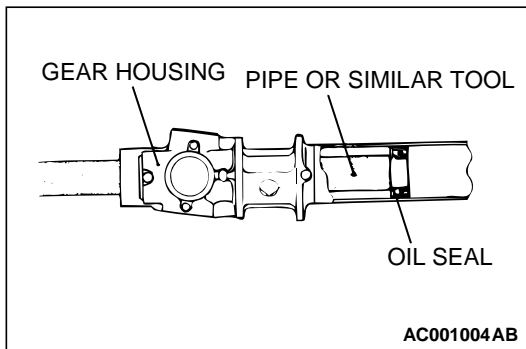

<<K>> OIL SEAL REMOVAL

CAUTION

Be careful not to damage the inner surface of the rack cylinder of the gear housing.

Use a piece of pipe or similar tool to remove the oil seal from the gear housing.

ASSEMBLY SERVICE POINTS

>>A<< OIL SEAL INSTALLATION

1. Apply a coating of the MITSUBISHI POWER STEERING FLUID to the both sides of the oil seal.
2. Using special tools MB991199 and MB991197, press the oil seal into the rack housing.

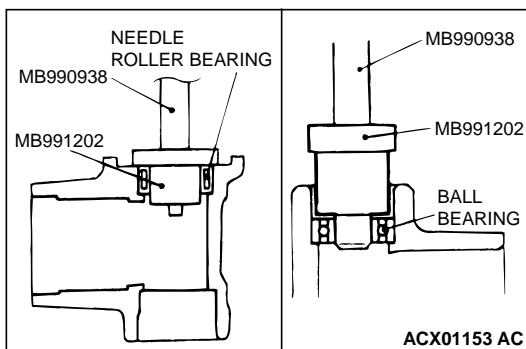
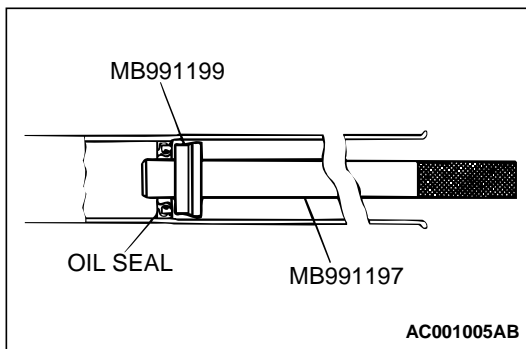

>>B<< NEEDLE ROLLER BEARING/BALL BEARING INSTALLATION

CAUTION

Press-fit straight. Valve housing is aluminum, and may become deformed if Press-fit on an angle.

1. Apply MITSUBISHI POWER STEERING FLUID to housing, bearing and oil seal press fitting surface.
2. Press fit needle roller bearing with special tools MB990938 and MB991202.

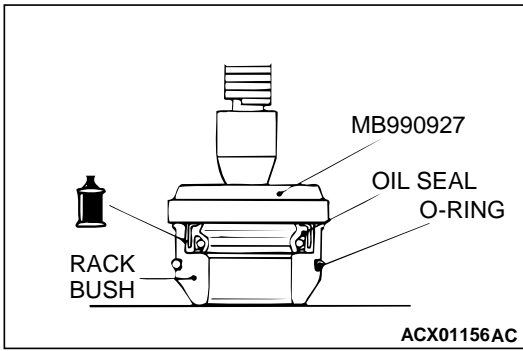

>>C<< OIL SEAL/O-RING INSTALLATION

1. Apply a coating of the MITSUBISHI POWER STEERING FLUID to the outside of the oil seal and O-ring.
2. Use special tool MB990927 to press fit oil seal until it touches rack bush end.

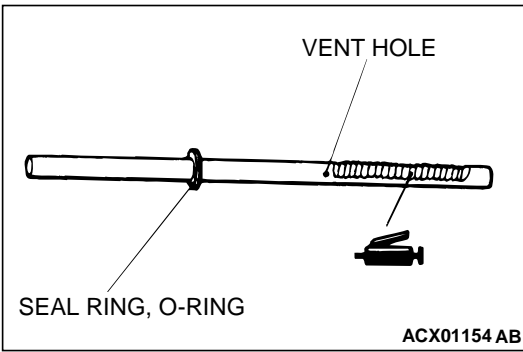

>>D<< RACK INSTALLATION

CAUTION

Do not close the vent hole in the rack with grease.

1. Apply a coating of multipurpose grease to the rack teeth face.

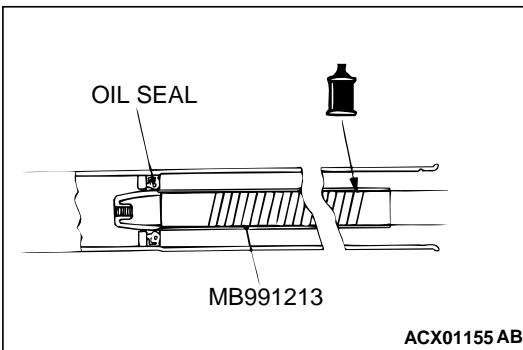

2. Cover rack serrations with special tool MB991213.
3. Apply MITSUBISHI POWER STEERING FLUID to special tool MB991213.
4. Align center of oil seal with rack to prevent retainer spring from slipping. Slowly insert rack from power cylinder side.

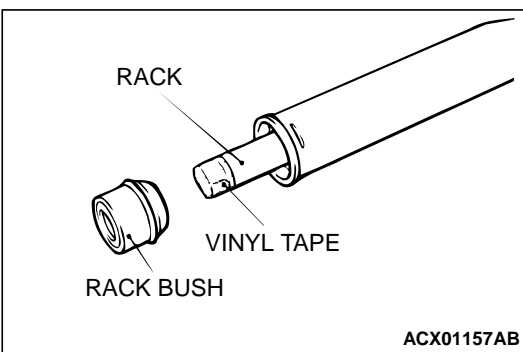

>>E<< RACK BUSHING INSTALLATION

CAUTION

Do not allow oil seal retainer spring to slip out.

Wrap the rack end with vinyl tape, apply a coating of the MITSUBISHI POWER STEERING FLUID, and then install the rack bushing and rack stopper.

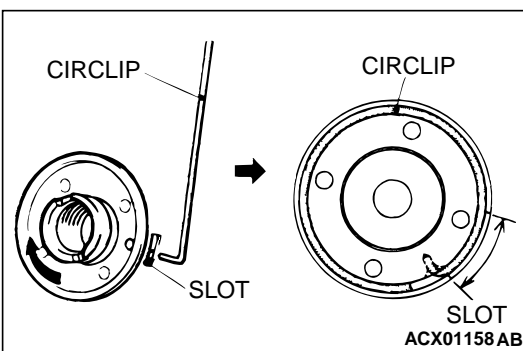

>>F<< CIRCLIP INSTALLATION

CAUTION

Insert circlip to rack stopper hole whilst turning rack stopper clockwise.

Insert circlip to rack stopper hole through cylinder hole. Turn rack stopper clockwise and insert circlip firmly.

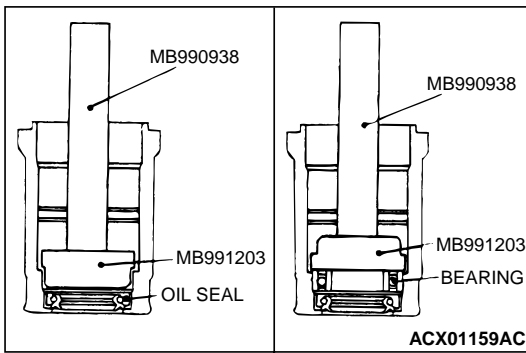

>>G<< OIL SEAL/BALL BEARING INSTALLATION

Apply a coating of the MITSUBISHI POWER STEERING FLUID to the outside of the oil seal/ball bearing. Using special tools MB990938 and MB991203, press the oil seal/ball bearing into the valve housing.

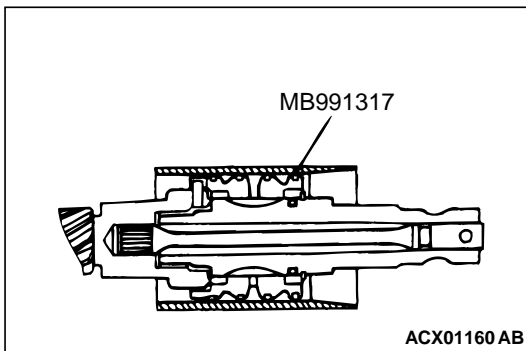

>>H<< SEAL RING INSTALLATION

Because the seal rings expand after installation, tighten after installing by using special tool MB991317 to compress the rings, or press down by hand.

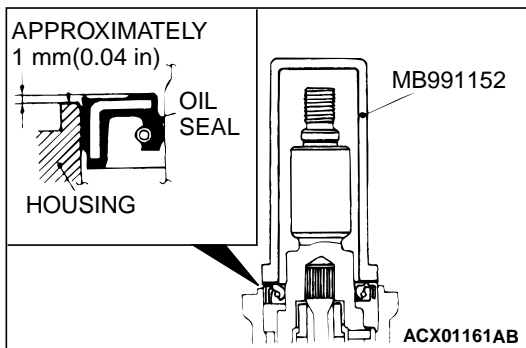

>>I<< OIL SEAL INSTALLATION

⚠ CAUTION

To eliminate a seal malfunction at the valve housing alignment surface, the upper surface of the oil seal should project outward approximately 1 mm (0.04 inch) from the housing edge surface.

Using special tool MB991152, press the oil seal into the valve housing.

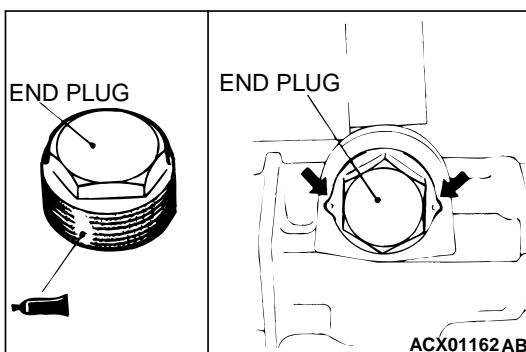

>>J<< END PLUG INSTALLATION

1. Apply the 3M™ AAD Part number 8672, 8679, 8678, 8661, 8663 or equivalent to the threaded part of the end plug.
2. Secure the threaded portion of the end plug at two places by using a punch.

>>K<< RACK SUPPORT COVER/JAM NUT INSTALLATION

1. Position rack at its center.
2. Apply the 3M™ AAD Part number 8672, 8679, 8678, 8661, 8663 or equivalent to the threaded part of the rack support cover.

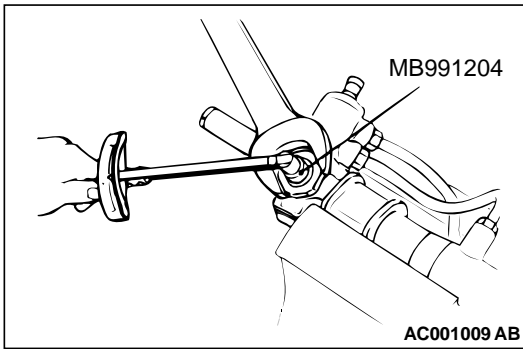

3. Use special tool MB991204 to tighten rack support cover to 13 ± 2 N·m (109 ± 21 in-lb).
4. Turn the rack support cover by 10 degree counterclockwise.
5. Use special tool MB991204 to hold the rack support cover, and then tighten the jam nut to 59 ± 10 N·m (44 ± 7 ft-lb).

>>L<< TOTAL PINION TORQUE ADJUSTMENT

⚠ CAUTION

- When adjusting, set at the highest value of the standard value range.
- Be sure there is no ratcheting or catching when operating the rack towards the shaft.
- Measure the total pinion torque through the whole stroke of the rack.

NOTE: If the total pinion torque cannot be adjusted to the standard value within the specified return angle, check the rack support cover components and replace any parts if necessary.

1. Using special tool MB990228 or MB991006, rotate the pinion shaft at the rate of one rotation in four to six seconds to check the total pinion torque and the change in torque.

Standard value:

Total pinion torque: 0.8 – 1.9 mm (6.9 – 16.5 in-lb)

[Change in torque: 0.7 N·m (6.1 in-lb) or less]

2. If the total pinion torque or the change in torque is outside the standard value, return the rack support cover within 0 degree angle to 30 degree angle, and adjust again.

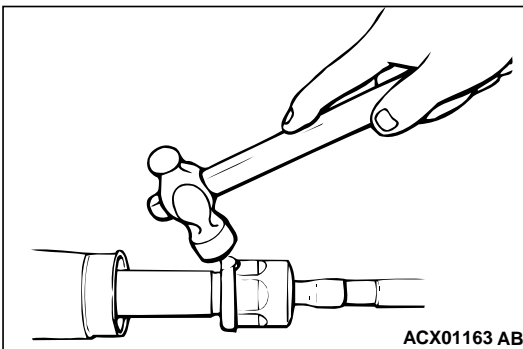
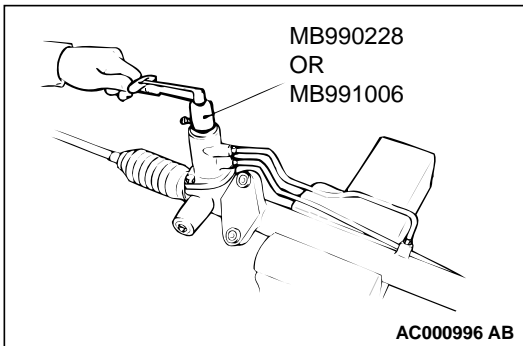

>>M<< TAB WASHER/TIE ROD INSTALLATION

After installing tie rod to rack, fold tab washer end (two locations) to tie rod notch.

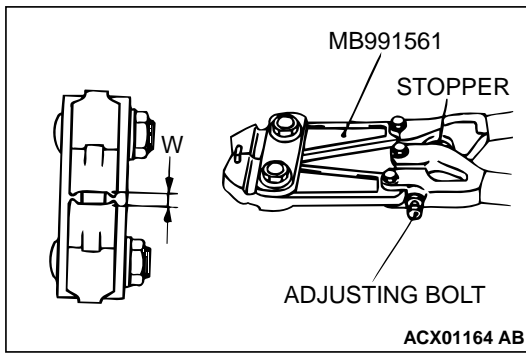

>>N<< BELLOWS BAND INSTALLATION

1. Turn the adjusting bolt of special tool MB991561 to adjust the opening dimension (W) to the standard value.

NOTE: The dimension (W) is adjusted by approximately 0.7 mm (0.03 inch) per one turn.

NOTE: Do not turn the adjusting bolt more than one turn.

Standard value (W): 1.9 mm (0.07 inch)

<When more than 1.9 mm (0.07 inch)>: Screw in the adjusting bolt.

<When less than 1.9 mm (0.07 inch)>: Loosen the adjusting bolt.

⚠ CAUTION

- Hold the rack housing, and use special tool MB991561 to crimp the bellows band securely.
- Crimp the bellows band until special tool MB991561 touches the stopper.

2. Use special tool MB991561 to crimp the bellows band.

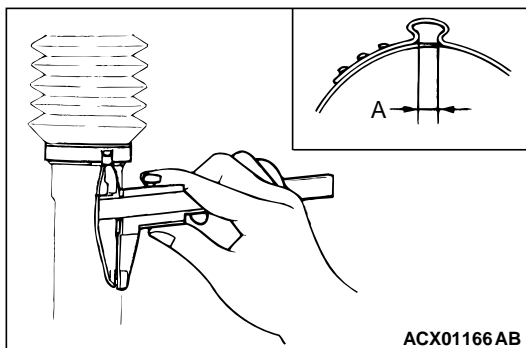
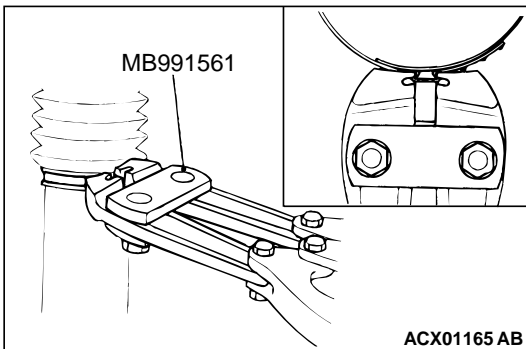

3. Check that crimped width (A) is within the standard value.

Standard value (A): 1.4 – 1.8 mm (0.06 – 0.07 inch)

<When more than 1.8 mm (0.07 inch)>: Readjust the dimension (W) of step (1) to the value calculated by the following equation, and repeat step (2).

$W = 5.5 \text{ mm (0.22 inch)} - A$ [Example: if (A) is 1.9 mm (0.07 inch), (W) is 3.6 mm (0.14 inch).]

<When less than 1.4 mm (0.06 inch)>: Remove the bellows band, readjust the dimension (W) of step (1) to the value calculated by the following equation, and use a new bellows band to repeat steps (2) to (3).

$W = 5.5 \text{ mm (0.22 inch)} - A$ [Example: if (A) is 1.3 mm (0.05 inch), (W) is 4.2 mm (0.17 inch).]

>>O<< TIE ROD END/TIE ROD END JAM NUT INSTALLATION

Screw in the tie rod end to achieve the right and left length as illustrated. Lock with the jam nut.

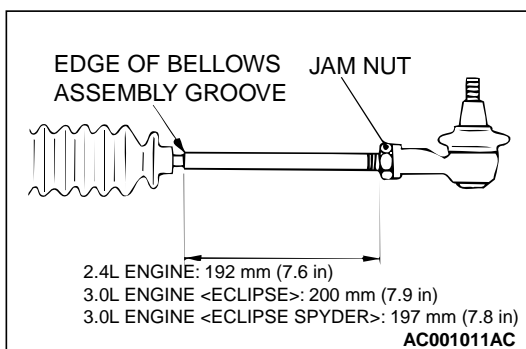

INSPECTION

M1372004400051

RACK

- Check the rack tooth surfaces for damage or wear.
- Check the oil seal contact surfaces for uneven wear.
- Check the rack for bends.

PINION AND VALVE ASSEMBLY

- Check the pinion gear tooth surfaces for damage or wear.
- Check for worn or defective seal ring.

BEARING

- Check for roughness or abnormal noise during bearing operation.
- Check the bearing for play.
- Check the needle roller bearings for roller slip-off.

OTHERS

- Check the cylinder inner surface of the rack housing for damage.
- Check the boots for damage, cracking or deterioration.
- Check the rack support for uneven wear or dents.
- Check the rack bushing for uneven wear or damage.

**TIE ROD END BALL JOINT DUST COVER
REPLACEMENT**

M1372008200093

If the dust cover is damaged accidentally during service work, replace the dust cover as follows:

1. Apply grease to the lip and inside of the dust cover.
2. Drive in the dust cover with special tool MB990776 until it is fully seated.
3. Check the dust cover for cracks or damage by pushing it with your finger.

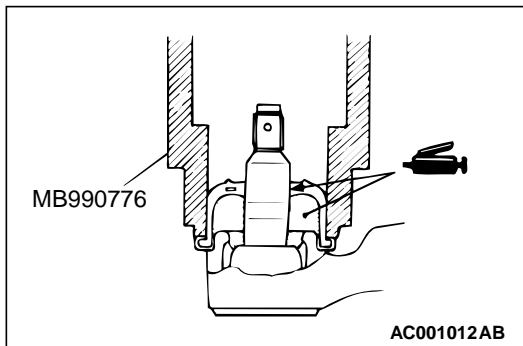

POWER STEERING OIL PUMP ASSEMBLY

REMOVAL AND INSTALLATION

M1372005200072

<p>Pre-removal Operation</p> <ul style="list-style-type: none"> Power Steering Fluid Draining (Refer to P.37A-16.) 	<p>Post-installation Operation</p> <ul style="list-style-type: none"> Power Steering Fluid Level Check (Refer to P.37A-16.) Drive Belt Tension Check (Refer to P.37A-16.) Power Steering Fluid Line Bleeding (Refer to P.37A-17.) Oil Pump Pressure Test (Refer to P.37A-18.)
--	--

<2.4L ENGINE>

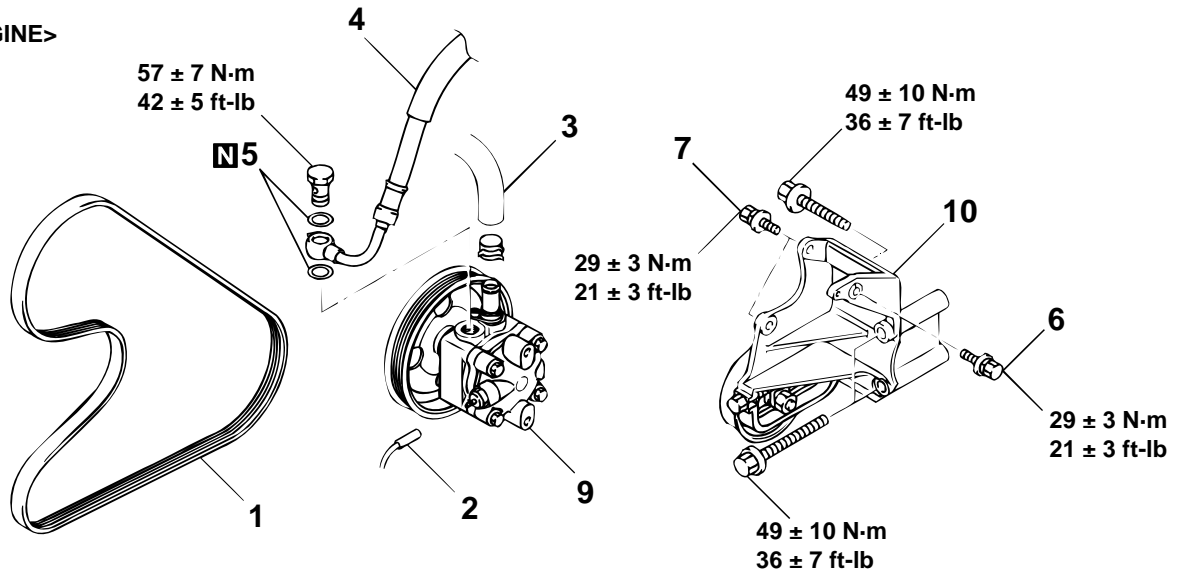

<3.0L ENGINE>

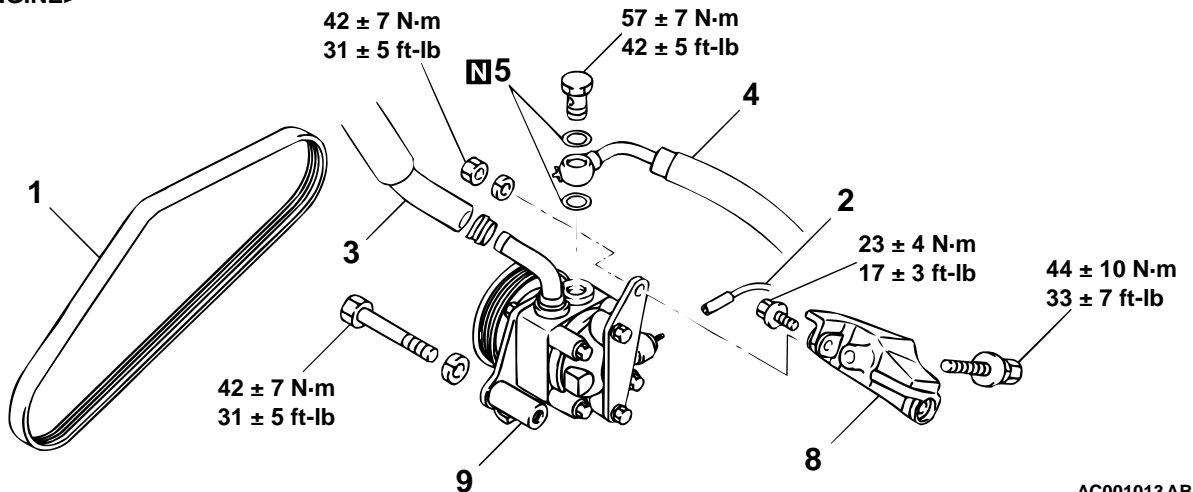

AC001013AB

REMOVAL STEPS

- DRIVE BELT
- PRESSURE SWITCH CONNECTOR
- SUCTION HOSE
- PRESSURE HOSE
- GASKET
- BOLT

REMOVAL STEPS (Continued)

- BOLT
- POWER STEERING PUMP BRACKET
- OIL PUMP
- OIL PUMP BRACKET

INSPECTION

Check the drive belt for cracks.
Check the driveshaft assembly for uneven rotation.

M1372005300057

TSB Revision

DISASSEMBLY AND ASSEMBLY

CAUTION

Do not disassemble the pressure switch assembly and valve subassembly.

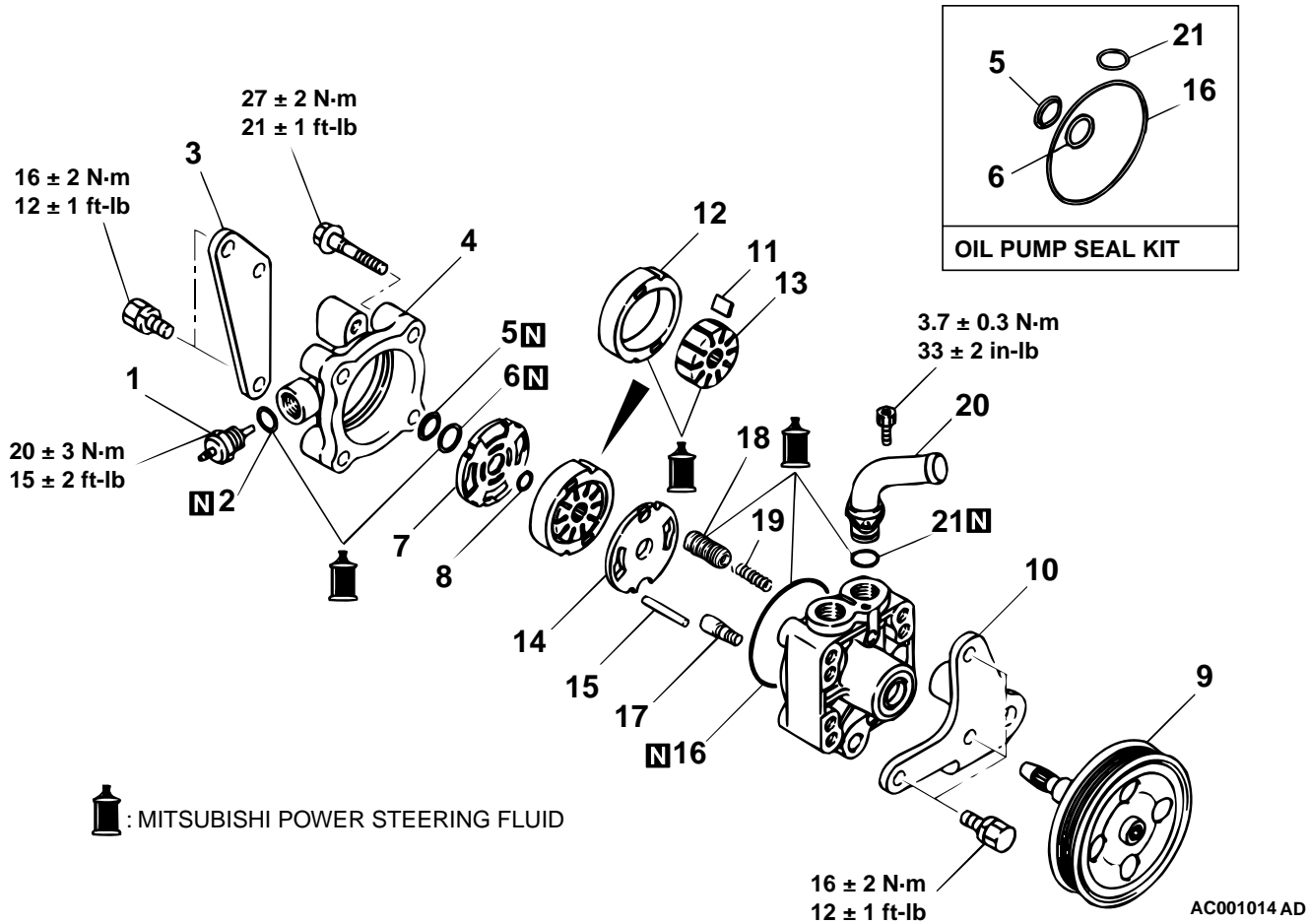

DISASSEMBLY STEPS

1. PRESSURE SWITCH ASSEMBLY
2. O-RING
3. REAR BRACKET <3.0L ENGINE>
4. REAR COVER
- >>A<< 5. BACKUP RING
- >>A<< 6. O-RING
7. SIDE PLATE (REAR)
8. SNAP RING
9. DRIVESHAFT ASSEMBLY
10. FRONT BRACKET <3.0L ENGINE>
- >>D<< 11. VANE

DISASSEMBLY STEPS (Continued)

- >>C<< 12. CAM RING
- >>B<< 13. ROTOR
14. SIDE PLATE (FRONT)
15. LOCK PIN
16. O-RING
17. VALVE SUBASSEMBLY
18. SPOOL ASSEMBLY
19. SPRING
20. SUCTION PIPE
- >>A<< 21. O-RING

ASSEMBLY SERVICE POINTS

>>A<< O-RING INSTALLATION

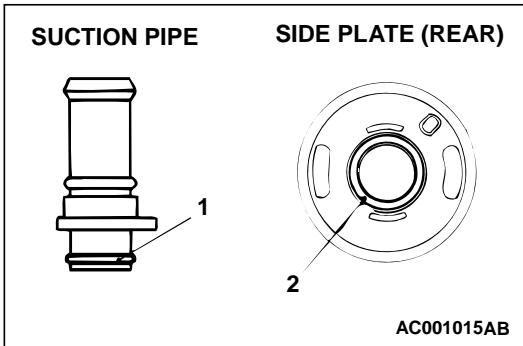

NO.	ID × WIDTH mm (in)
1	13.3 × 1.6 (0.52 × 0.06)
2	15.0 × 2.0 (0.59 × 0.08)

>>B<< ROTOR INSTALLATION

Install the rotor to the pulley assembly so that the rotor's punch mark is at the pump cover side.

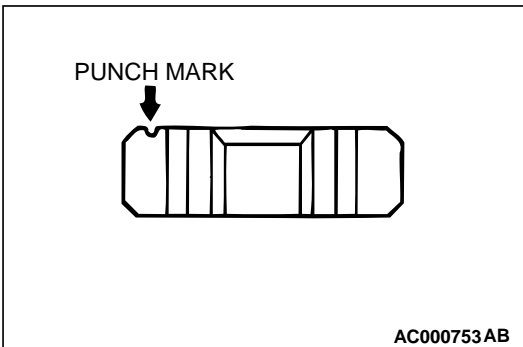

>>C<< CAM RING INSTALLATION

Install the cam ring with the punch mark facing the side plate.

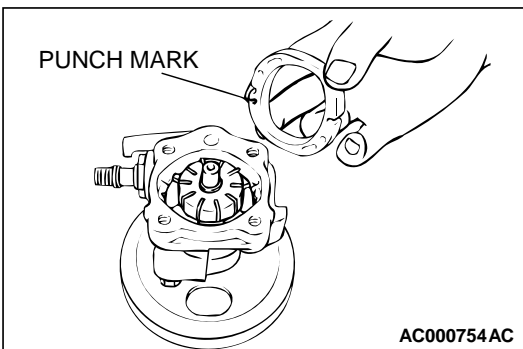

>>D<< VANE INSTALLATION

Install the vanes on the rotor, paying close attention to the installation direction.

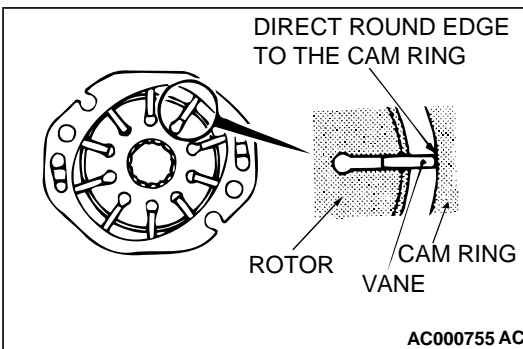

INSPECTION

M1372005500073

- Check the valve subassembly for clogging.
- Check the driveshaft assembly for wear or damage.
- Check the rotor and vane groove for "stepped" wear.
- Check the contact surface of cam ring and vanes for "stepped" wear.
- Check the vanes for damage.

POWER STEERING HOSES

REMOVAL AND INSTALLATION

M1372005700077

<p>Pre-removal Operation</p> <ul style="list-style-type: none"> • Power Steering Fluid Draining (Refer to P.37A-16.) 	<p>Post-installation Operation</p> <ul style="list-style-type: none"> • Power Steering Fluid Level Check (Refer to P.37A-16.) • Power Steering Fluid Line Bleeding (Refer to P.37A-17.)
--	--

<2.4L ENGINE>

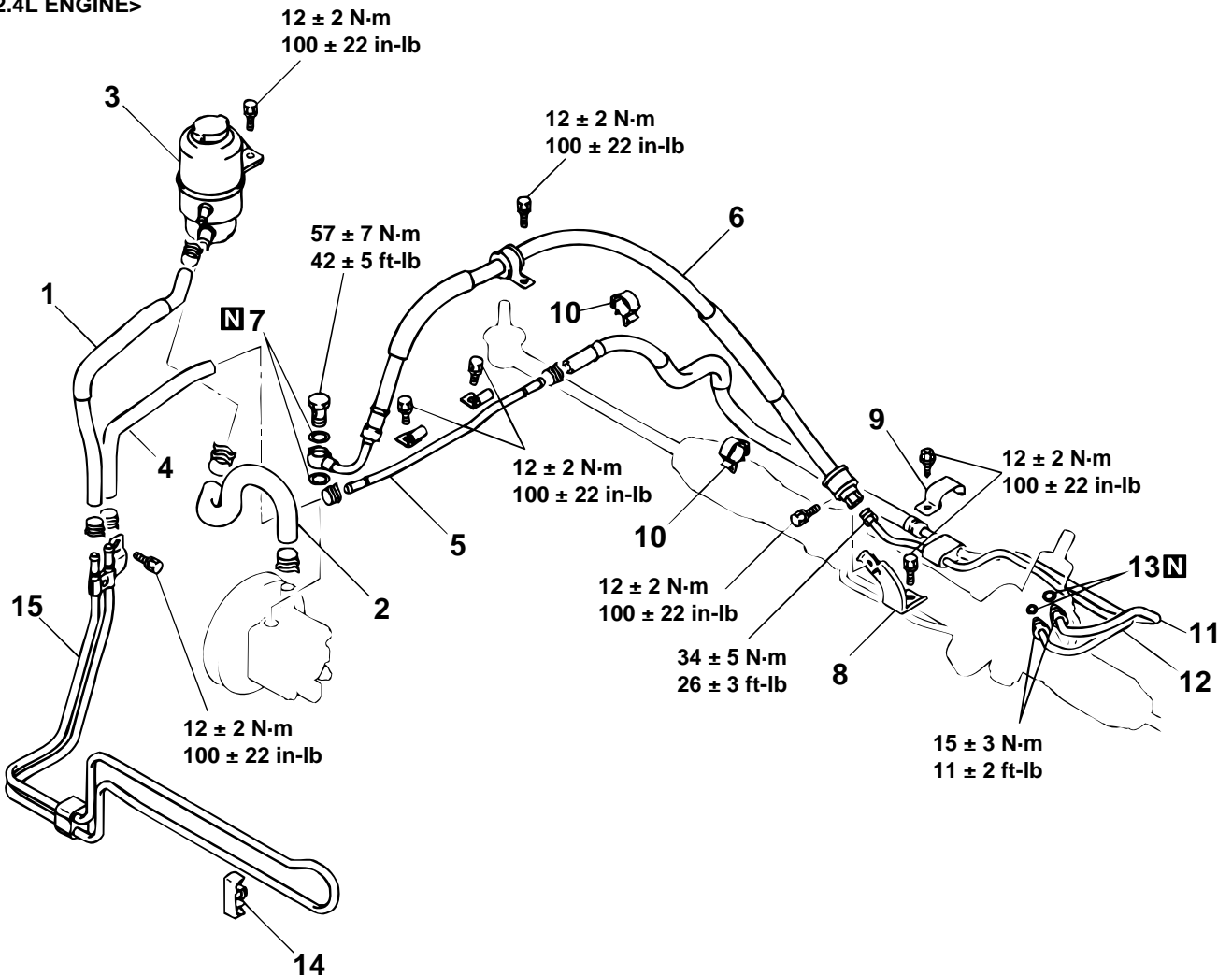

AC001019AB

REMOVAL STEPS

- >>F<< 1. RETURN HOSE
- >>E<< 2. SUCTION HOSE
- 3. OIL RESERVOIR
- >>D<< 4. RETURN HOSE
- 5. RETURN TUBE
- >>C<< 6. PRESSURE HOSE
- 7. O-RING
- 8. BRACKET
- 9. CLAMP

REMOVAL STEPS (Continued)

- 10. CLIP
- >>B<< 11. RETURN HOSE ASSEMBLY
- >>A<< 12. PRESSURE TUBE ASSEMBLY
- 13. O-RING
- FRONT BUMPER (REFER TO GROUP 51, FRONT BUMPER P.51-3.)
- 14. CLIP
- 15. COOLER TUBE ASSEMBLY

<3.0L ENGINE>

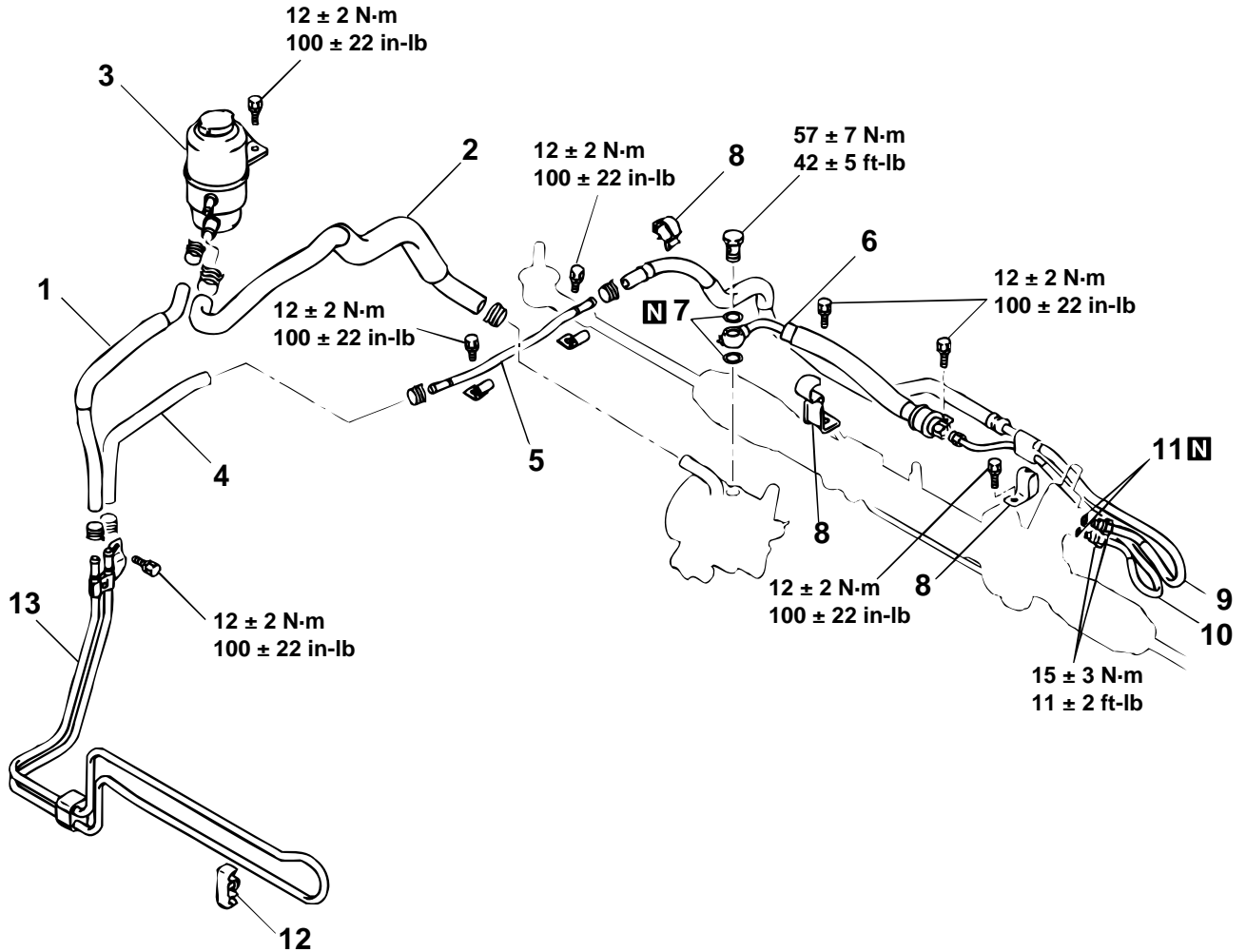

AC001020 AB

REMOVAL STEPS

- >>F<< 1. RETURN HOSE
- >>E<< 2. SUCTION HOSE
- 3. OIL RESERVOIR
- >>D<< 4. RETURN HOSE
- 5. RETURN TUBE
- >>C<< 6. PRESSURE HOSE
- 7. O-RING
- 8. CLIP

REMOVAL STEPS (Continued)

- >>B<< 9. RETURN HOSE ASSEMBLY
- >>A<< 10. PRESSURE TUBE ASSEMBLY
- 11. O-RING
 - FRONT BUMPER ASSEMBLY (REFER TO GROUP 51, FRONT BUMPER P.51-3.)
- 12. CLIP
- 13. COOLER TUBE ASSEMBLY

INSTALLATION SERVICE POINTS**>>A<< PRESSURE TUBE ASSEMBLY INSTALLATION**

Align the marks on the pressure tube assembly and steering gear box, and install the pressure tube assembly.

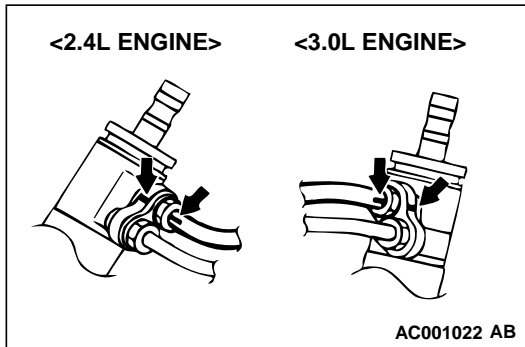
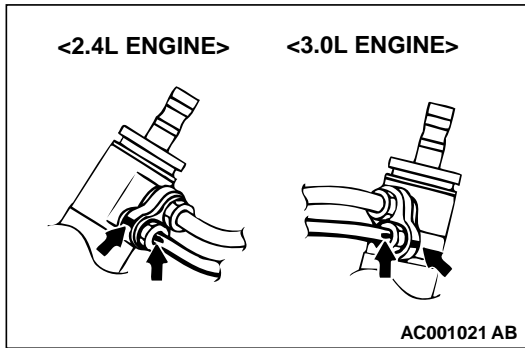
**>>B<< RETURN HOSE ASSEMBLY INSTALLATION**

1. Align the marks on the return hose assembly and steering gear box, and install the return hose assembly.

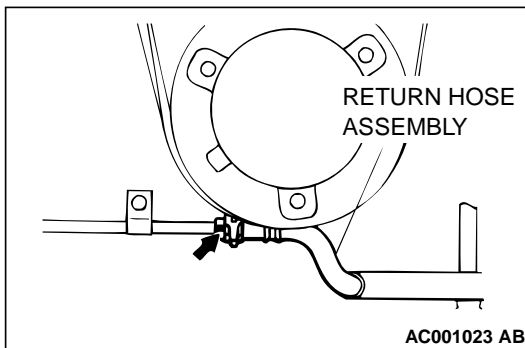

2. Install the return hose assembly so that the marking is positioned as shown in the illustration.

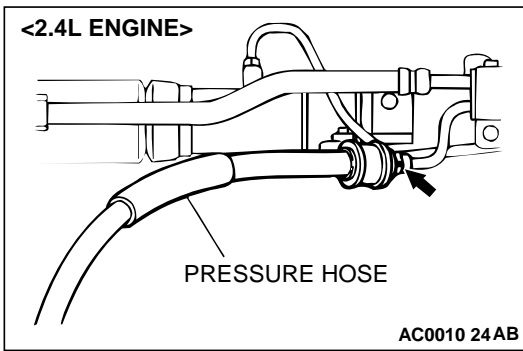

>>C<< PRESSURE HOSE INSTALLATION

1. Install the pressure hose at the gear box side so that the marking is positioned as shown in the illustration.

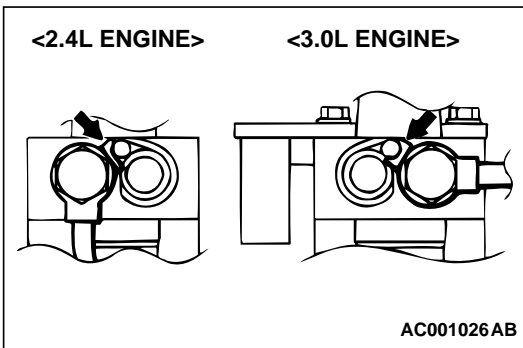
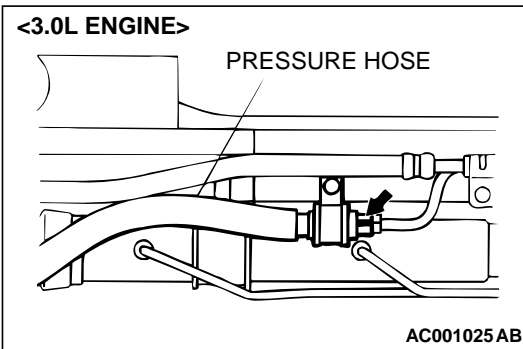

2. Install the pressure hose at the power steering oil pump side as shown in the illustration.

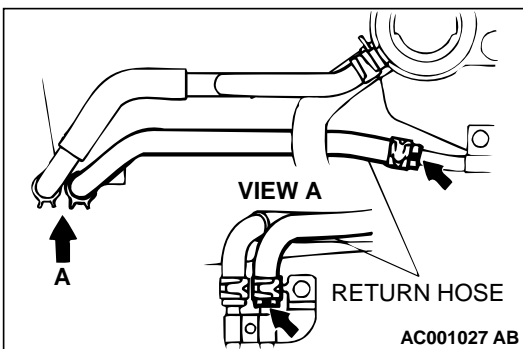

>>D<< RETURN HOSE INSTALLATION

Install the return hose so that the markings are positioned as shown in the illustration.

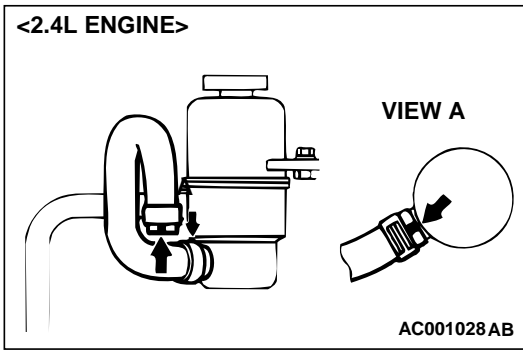

>>E<< SUCTION HOSE INSTALLATION

Install the suction hose so that the markings are positioned as shown in the illustration.

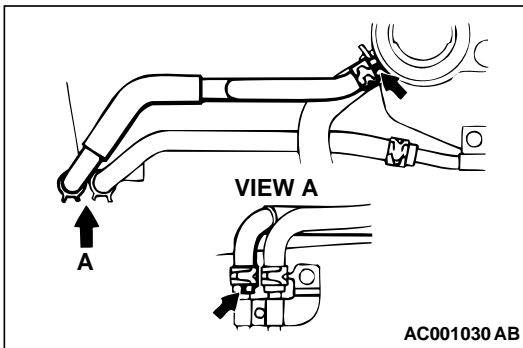
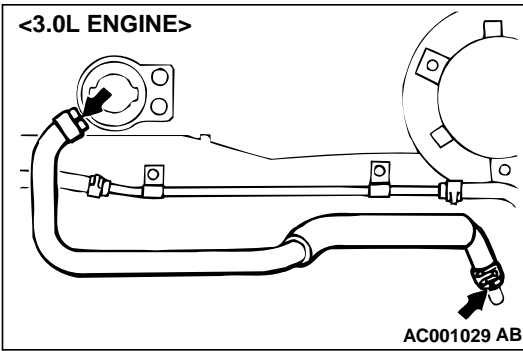

>>F<< RETURN HOSE INSTALLATION

Install the return hose so that the markings are positioned as shown in the illustration.

SPECIFICATIONS

FASTENER TIGHTENING SPECIFICATIONS

M1372008400075

ITEMS	SPECIFICATIONS	
Power steering gear box		
Cylinder clamp assembly nut, gear box assembly bolt <3.0L ENGINE>	69 ± 9 N·m (51 ± 7 ft-lb)	
Cylinder clamp assembly bolt, gear box assembly bolt <2.4L ENGINE>	69 ± 9 N·m (51 ± 7 ft-lb)	
End plug	59 ± 10 N·m (44 ± 7 ft-lb)	
Feed tube flare nut	13 ± 3 N·m (113 ± 26 in-lb)	
Pinion and valve assembly jam nut	25 ± 4 N·m (18 ± 4 ft-lb)	
Rack support cover	13 ± 2 N·m (109 ± 21 in-lb)	
Rack support cover jam nut	59 ± 10 N·m (44 ± 7 ft-lb)	
Return hose flare nut, pressure tube flare nut	15 ± 3 N·m (11 ± 2 ft-lb)	
Stay bolt <2.4L ENGINE>	74 ± 4 N·m (55 ± 3 ft-lb)	
Steering shaft and gear box connecting bolt	18 ± 2 N·m (13 ± 1 ft-lb)	
Tie rod	88 ± 10 N·m (65 ± 7 ft-lb)	
Tie rod end nut	52 ± 2 N·m (38 ± 2 ft-lb)	
Tie rod end to knuckle fixing nut	29 ± 4 N·m (21 ± 4 ft-lb)	
Valve housing bolt	19 ± 3 N·m (14 ± 2 ft-lb)	
Power steering hose		
Oil pump eye bolt	57 ± 7 N·m (42 ± 5 ft-lb)	
Oil reservoir, pressure hose, pressure tube, return tube, cooler tube bolt	12 ± 2 N·m (100 ± 22 in-lb)	
Pressure tube flare nut (Gear box side)	15 ± 3 N·m (11 ± 2 ft-lb)	
Pressure tube flare nut (Pressure hose side)	34 ± 5 N·m (26 ± 3 ft-lb)	
Power steering oil pump		
Front/rear bracket bolt <3.0L ENGINE>	16 ± 2 N·m (12 ± 1 ft-lb)	
Oil pump bolt/nut <3.0L ENGINE>	42 ± 7 N·m (31 ± 5 ft-lb)	
Oil pump bracket bolt	M8 <2.4L ENGINE>	29 ± 3 N·m (21 ± 3 ft-lb)
	M10 <2.4L ENGINE>	49 ± 10 N·m (36 ± 7 ft-lb)
	M8 <3.0L ENGINE>	23 ± 4 N·m (17 ± 3 ft-lb)
	M10 <3.0L ENGINE>	44 ± 10 N·m (33 ± 7 ft-lb)
Oil pump eye bolt	57 ± 7 N·m (42 ± 5 ft-lb)	
Pressure switch assembly	20 ± 3 N·m (15 ± 2 ft-lb)	
Rear cover bolt	27 ± 2 N·m (21 ± 1 ft-lb)	
Suction pipe bolt	3.7 ± 0.3 N·m (33 ± 2 in-lb)	
Power steering wheel and shaft		
Clock spring and column switch assembly bolt	25 ± 4 N·m (18 ± 4 ft-lb)	
Steering shaft and gear box connecting bolt	18 ± 2 N·m (13 ± 1 ft-lb)	

ITEMS	SPECIFICATIONS
Steering column assembly bolt	12 ± 2 N·m (100 ± 22 in-lb)
Steering cover assembly bolt	4.9 ± 1.0 N·m (44 ± 8 in-lb)
Steering wheel nut	41 ± 8 N·m (31 ± 5 ft-lb)

GENERAL SPECIFICATIONS

M1372000200077

ITEMS	SPECIFICATIONS	
Power steering gear box	Type	Rack and pinion
	Gear ratio	45.74
Oil pump	Type	Vane type
	Displacement cm ³ /rev (cu in/rev)	9.6 (0.59)
	Relief set pressure MPa (psi)	8.8 (1,276)

SERVICE SPECIFICATIONS

M1372000300074

ITEMS	STANDARD VALUE	LIMIT		
Steering wheel free play mm (in)	With engine running	–	30 (1.2)	
	With engine stopped	10 (0.4) or less	–	
Steering angle	Inside wheel	2.4L ENGINE	36°12' ± 2°00'	–
		3.0L ENGINE <ECLIPSE>	31°00' ± 2°00'	–
		3.0L ENGINE <ECLIPSE SPYDER>	33°60' ± 2°00'	–
	Outside wheel (reference)	2.4L ENGINE	30°24'	–
		3.0L ENGINE <ECLIPSE>	27°00'	–
		3.0L ENGINE <ECLIPSE SPYDER>	28°30'	–
Toe-in mm (in)	0 ± 3 (0 ± 0.12)	–		
Tie rod end ball joint breakaway torque N·m (in-lb)	0.5 – 2.5 (4.4 – 22.1)	–		
Tie rod swing resistance N (lb) [N·m (in-lb)]	4.0 – 18.6 (17.8 – 82.7) [1.0 – 4.9 (8.7 – 43.4)]	–		
Engine idle speed r/min	2.4L ENGINE	750 ± 100	–	
	3.0L ENGINE	700 ± 100	–	
Stationary steering effort N (lb) [Fluctuation allowance N (lb)]	30 (6.7) or less [5.9 (1.33)]	–		
Oil pump pressure MPa (psi)	Oil pump relief pressure	8.3 – 9.5 (1,209 – 1,280)	–	
	Pressure under no-load conditions	0.8 – 1.0 (116 – 145)	–	
	Steering gear retention hydraulic pressure	8.3 – 9.5 (1,209 – 1,280)	–	
Oil pressure switch operating pressure MPa (psi)	OFF → ON	1.8 – 2.4 (261 – 348)	–	
	ON → OFF	0.8 – 2.4 (116 – 348)	–	

ITEMS	STANDARD VALUE	LIMIT
Gear box total pinion torque N·m (in-lb) [Change in torque: 0.7 N·m (6.1 in-lb) or less]	0.8 – 1.9 (6.9 – 16.5)	–
Opening dimension of special tool MB991561 mm (in)	1.9 (0.07)	–
Band crimped width mm (in)	1.4 – 1.8 (0.06 – 0.07)	–

LUBRICANTS

M1372000400071

ITEMS	SPECIFIED LUBRICANTS	QUANTITY dm ³ (qt)	
Gear box	Bearing	MITSUBISHI POWER STEERING FLUID	
	O-ring		
	Oil seal		
	Special tool (MB991213)		
	Pinion and valve assembly seal ring part		
	Bellows	Silicon grease	As required
Oil pump	Power steering fluid	MITSUBISHI POWER STEERING FLUID	0.8 (0.85)
	Friction surface of rotor vane, cam ring and pump cover	MITSUBISHI POWER STEERING FLUID	As required
	O-ring		

SEALANTS

M1372000500078

ITEMS	SPECIFIED SEALANTS
Power steering gear box	End plug
	Rack support cover

3M™ AAD Part No.8672, 8679, 8678, 8661, 8663 or equivalent

NOTES