

GROUP 21B

CLUTCH OVERHAUL <F5M42>

CONTENTS

CLUTCH	21B-2	SPECIFICATIONS	21B-8
DISASSEMBLY AND ASSEMBLY	21B-2	FASTENER TIGHTENING SPECIFICATIONS.....	21B-8
CLUTCH INSPECTION.....	21B-4	GENERAL SPECIFICATIONS	21B-8
CLUTCH RELEASE CYLINDER	21B-6	SERVICE SPECIFICATIONS	21B-8
DISASSEMBLY AND ASSEMBLY	21B-6	LUBRICANTS	21B-8
CLUTCH RELEASE CYLINDER INSPECTION	21B-7		

CLUTCH

DISASSEMBLY AND ASSEMBLY

M1212001000318

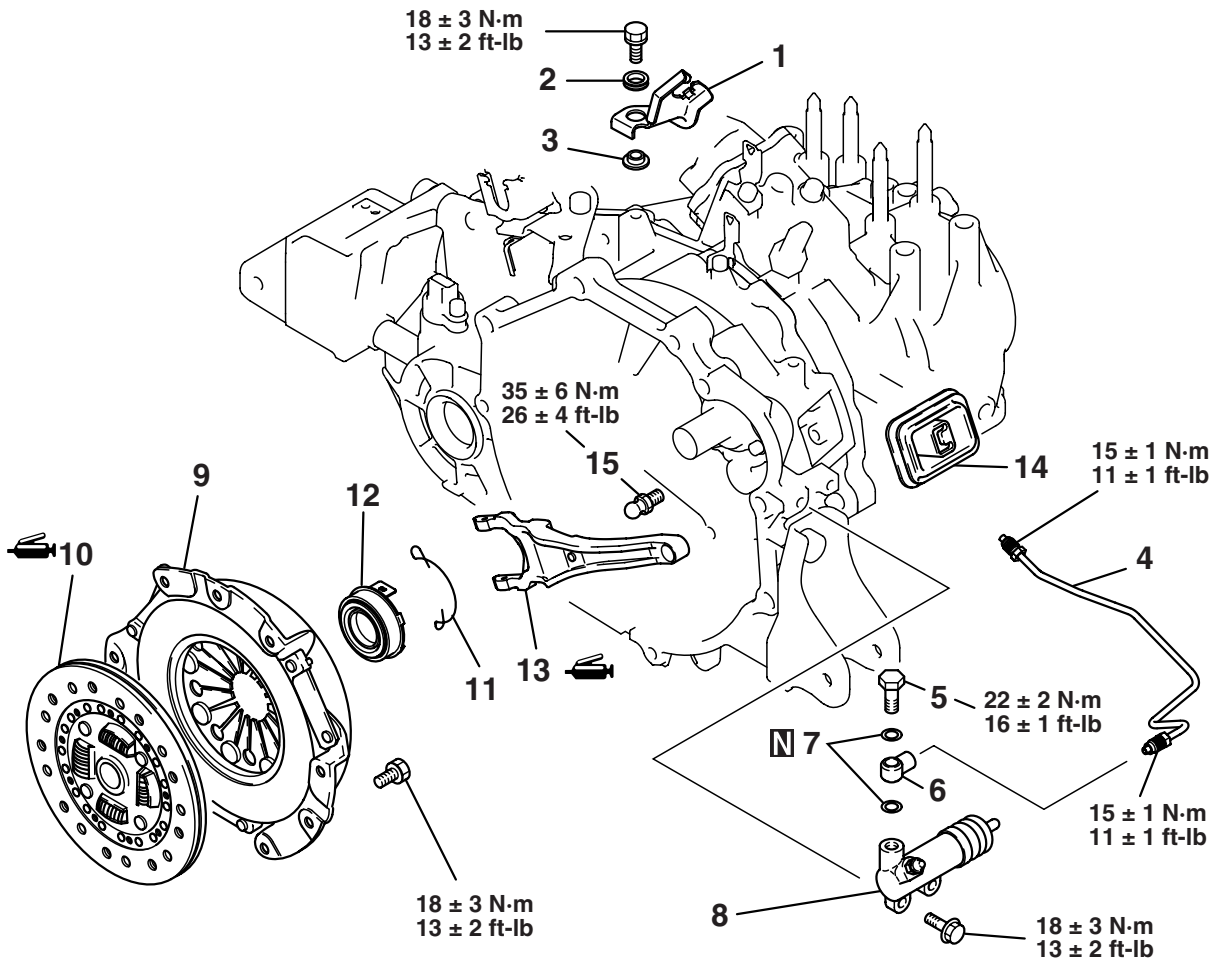

AK403236AB

REMOVAL STEPS

1. CLUTCH FLUID LINE BRACKET
2. INSULATOR
3. WASHER
4. CLUTCH TUBE
5. UNION BOLT
6. UNION
7. GASKET
8. CLUTCH RELEASE CYLINDER

REMOVAL STEPS (Continued)

- | | |
|-------------|----------------------------|
| >>B<< | 9. CLUTCH COVER |
| >>B<< | 10. CLUTCH DISC |
| | 11. RETURN CLIP |
| | 12. CLUTCH RELEASE BEARING |
| <<A>> >>A<< | 13. RELEASE FORK |
| | 14. RELEASE FORK BOOT |
| | 15. FULCRUM |

DISASSEMBLY SERVICE POINT

<<A>> RELEASE FORK REMOVAL

Move the release fork in the direction shown to remove the clip from the fulcrum.

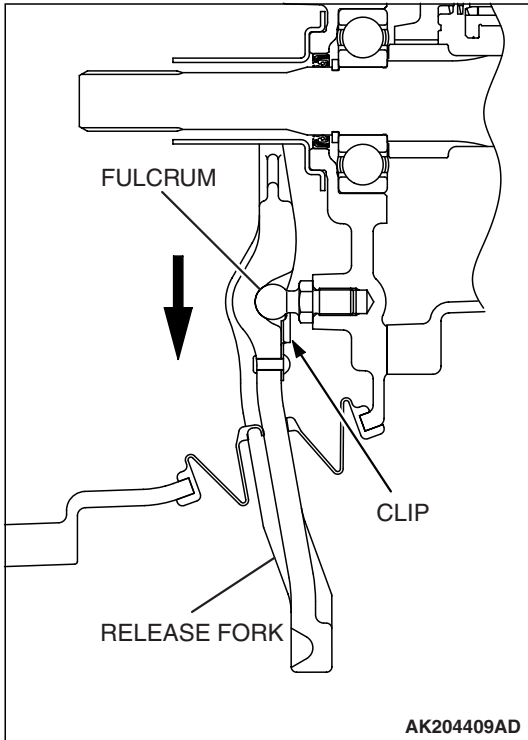

ASSEMBLY SERVICE POINTS

>>A<< RELEASE FORK INSTALLATION

1. Apply Mitsubishi Part number 0101011 or equivalent to the illustrated positions of the release fork.
2. Install the release fork to the fulcrum.

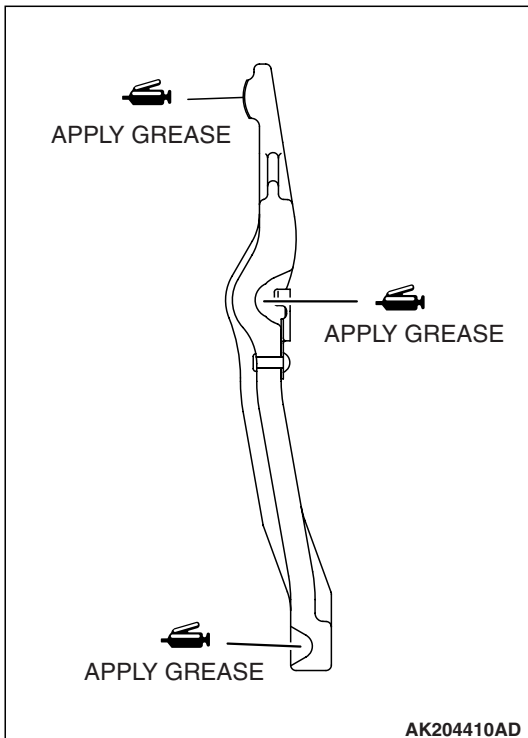

**>>B<< CLUTCH DISC AND CLUTCH COVER
INSTALLATION**

1. Apply Mitsubishi Part number 0101011 or equivalent to the clutch disc splines and rub it in the splines with a brush.
2. Using the clutch disc guide to position the clutch disc on the flywheel.
3. Install the clutch cover onto the flywheel.

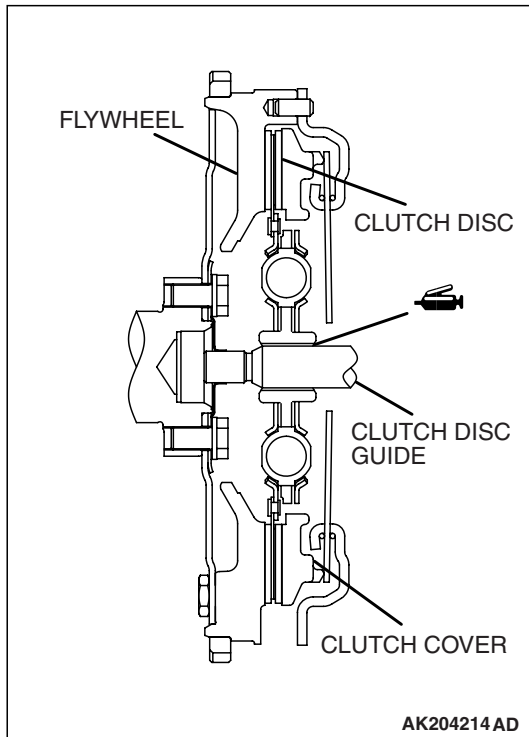
**CLUTCH INSPECTION**

M1212001100122

CLUTCH COVER

1. Check the diaphragm spring end for wear and uneven height. Replace if wear is evident or height difference exceeds the limit.
Limit: 0.5 mm (0.020 inch)
2. Check the pressure plate surface for wear, cracks and discoloration.
3. Check the rivets of the strap plate for looseness. If loose, replace the clutch cover.

CLUTCH DISC**⚠ CAUTION****Don't clean the clutch disc in a cleaning solvent.**

1. Check the facing for loose rivets, uneven contact, evidence of seizure, or deposited oils and greases. If defective, replace the clutch disc.

NOTE: If contaminated with grease or oil, determine the source of the contaminant and repair it.

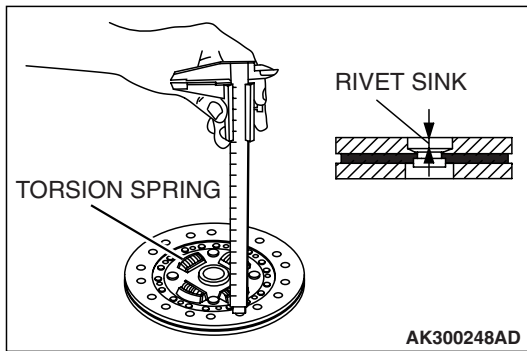

2. Measure the rivet sink. Replace the clutch disc if it is below the limit.
Minimum limit: 0.3 mm (0.012 inch)
3. Check the torsion spring for play and damage. If defective, replace the clutch disc.
4. Place the clutch disc on the input shaft and check for sliding condition and play in the rotating direction. If poor sliding condition is evident, clean, reassemble, and recheck. If excessive play is evident, replace the clutch disc and/or input shaft.

CLUTCH RELEASE BEARING

⚠ CAUTION

Release bearing is packed with grease. Therefore, do not wash it in a cleaning solvent.

1. Check for seizure, damage, noise or binding/rough rotation.
2. Check for wear on the surface which contacts with the diaphragm spring.
3. Check for wear on the surface which contacts with the release fork. If abnormally worn, replace.

RELEASE FORK

If the surface which contacts with the bearing is abnormally worn, replace.

CLUTCH RELEASE CYLINDER

DISASSEMBLY AND ASSEMBLY

M1212001500197

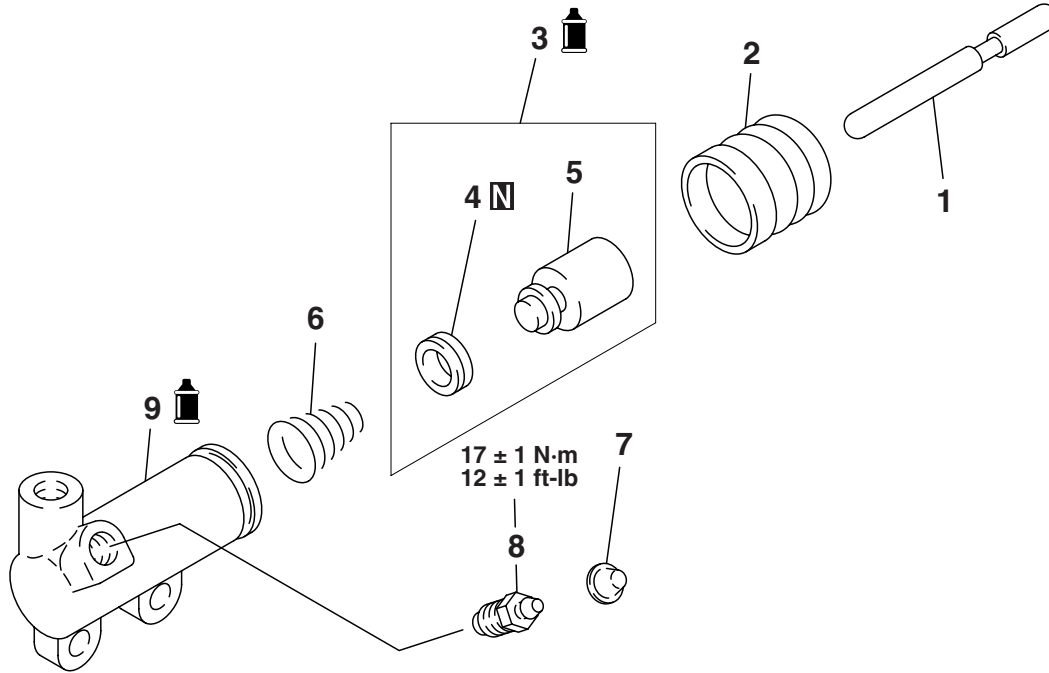

AK204216AD

DISASSEMBLY STEPS

DISASSEMBLY STEPS

<<A>> >>A<<

1. PUSH ROD
2. BOOT
3. PISTON ASSEMBLY
4. PISTON CUP
5. PISTON

6. CONICAL SPRING
7. CAP
8. AIR BLEEDER
9. RELEASE CYLINDER

DISASSEMBLY SERVICE POINT

<<A>> PISTON ASSEMBLY REMOVAL

1. Cover with a shop towel to prevent the piston from popping out.

⚠ CAUTION

Apply compressed air slowly to prevent brake fluid from splashing.

2. Apply the compressed air into the tube mounting hole to remove the piston assembly.

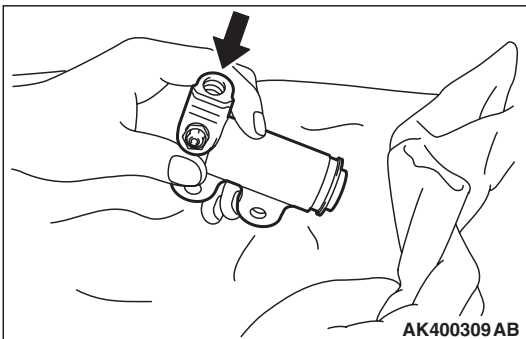

AK400309 AB

ASSEMBLY SERVICE POINT

>>A<< PISTON ASSEMBLY INSTALLATION

1. Apply brake fluid SAE J1703 (DOT3) to the piston cup and inner surface of the release cylinder.
2. Insert the piston assembly into the release cylinder.

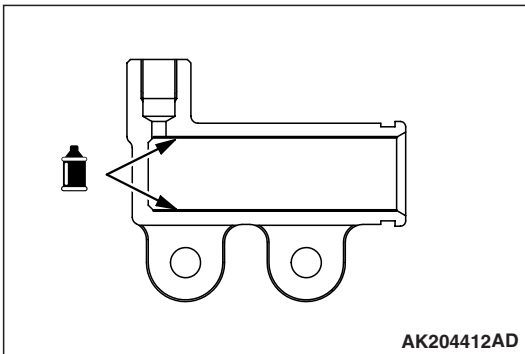
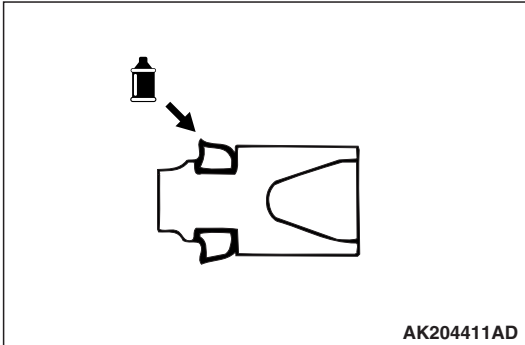

CLUTCH RELEASE CYLINDER INSPECTION

M1212001600138

PISTON CUP

Check the lip of piston cup for scratch. If it is scratched, check the inner surface of the release cylinder for scratches.

RELEASE CYLINDER

Check the inner surface of the release cylinder for scratches or abnormal wear, replace if necessary.

SPECIFICATIONS**FASTENER TIGHTENING SPECIFICATIONS**

M1212001800295

ITEM	SPECIFICATION
Clutch cover mounting bolt	18 ± 3 N· m (13 ± 2 ft-lb)
Concentric slave cylinder mounting bolt	10 ± 2 N· m (89 ± 17 in-lb)
Clutch fluid line bracket mounting bolt	20 ± 4 N· m (15 ± 3 ft-lb)

GENERAL SPECIFICATIONS

M1212000200397

ITEM	SPECIFICATION
Clutch operating method	Hydraulic type
Clutch disc type	Single dry disc type
Clutch disc size OD x ID mm (in)	240 x 155 (9.45 x 6.10)
Clutch cover type	Diaphragm spring type
Clutch cover setting load N (lb)	9,700 ± 900 (2,181 ± 202)

SERVICE SPECIFICATIONS

M1212000300264

ITEM	LIMIT
Diaphragm spring end height difference mm (in)	0.5 (0.020)
Clutch disc facing rivet sink mm (in)	Minimum 0.3 (0.012)

LUBRICANTS

M1212000400283

ITEM	SPECIFIED LUBRICANT
Clutch disc splines	Mitsubishi Part number 0101011 or equivalent