

## GROUP 17

# ENGINE AND EMISSION CONTROL

## CONTENTS

<b>ENGINE CONTROL</b> .....	<b>17-3</b>	AUTO-CRUISE CONTROL SYSTEM DIAGNOSTIC TROUBLESHOOTING STRATEGY .....	17-7
<b>GENERAL DESCRIPTION</b> .....	17-3	AUTO-CRUISE CONTROL SYSTEM DIAGNOSTIC TROUBLE CODE DIAGNOSIS .....	17-7
<b>ENGINE CONTROL SYSTEM DIAGNOSIS</b> .....	17-3	DIAGNOSTIC TROUBLE CODE CHART	17-10
INTRODUCTION TO ENGINE CONTROL SYSTEM DIAGNOSIS .....	17-3	DIAGNOSTIC TROUBLE CODE PROCEDURES .....	17-11
ENGINE CONTROL SYSTEM DIAGNOSTIC TROUBLESHOOTING STRATEGY ...	17-3	SYMPTOM CHART .....	17-38
SYMPTOM CHART .....	17-3	SYMPTOM PROCEDURES .....	17-39
SYMPTOM PROCEDURES .....	17-3	DATA LIST REFERENCE TABLE .....	17-74
<b>ON-VEHICLE SERVICE</b> .....	17-4	CHECK AUTO-CRUISE CONTROL-ECU TERMINALS .....	17-75
ACCELERATOR CABLE CHECK AND ADJUSTMENT .....	17-4	<b>ON-VEHICLE SERVICE</b> .....	17-77
<b>ACCELERATOR CABLE AND PEDAL</b> .....	17-5	AUTO-CRUISE CONTROL SWITCH CHECK .....	17-77
REMOVAL AND INSTALLATION .....	17-5	AUTO-CRUISE CONTROL SYSTEM COMPONENT CHECK .....	17-78
<b>AUTO-CRUISE CONTROL</b> ....	<b>17-6</b>	<b>AUTO-CRUISE CONTROL</b> .....	17-81
<b>GENERAL DESCRIPTION</b> .....	17-6	REMOVAL AND INSTALLATION .....	17-81
<b>SPECIAL TOOLS</b> .....	17-6	<b>EMISSION CONTROL</b> .....	<b>17-83</b>
<b>AUTO-CRUISE CONTROL SYSTEM DIAGNOSIS</b> .....	17-7	<b>GENERAL DESCRIPTION</b> .....	17-83
INTRODUCTION TO AUTO-CRUISE CONTROL SYSTEM DIAGNOSIS .....	17-7	<b>EMISSION CONTROL DIAGNOSIS</b>	17-83
		<b>SPECIAL TOOLS</b> .....	17-83

<b>VACUUM HOSES</b> .....	17-84	SOLENOID CHECK .....	17-95
VACUUM HOSE ROUTING .....	17-84	<b>EXHAUST GAS RECIRCULATION (EGR)</b>	
VACUUM CIRCUIT DIAGRAM .....	17-86	<b>SYSTEM</b> .....	17-96
VACUUM HOSE INSTALLATION .....	17-87	GENERAL DESCRIPTION .....	17-96
VACUUM HOSE CHECK .....	17-88	COMPONENT LOCATION .....	17-97
<b>POSITIVE CRANKCASE VENTILATION</b>		EGR SYSTEM CHECK .....	17-98
<b>SYSTEM</b> .....	17-88	VACUUM CONTROL VALVE CHECK ..	17-99
GENERAL DESCRIPTION (POSITIVE		EGR VALVE CHECK .....	17-99
CRANKCASE VENTILATION SYSTEM)	17-88	EGR PORT VACUUM CHECK .....	17-100
COMPONENT LOCATION .....	17-89	EGR SOLENOID CHECK .....	17-100
CRANKCASE VENTILATION SYSTEM		VOLUME AIR FLOW SENSOR CHECK	17-101
CHECK .....	17-90	ENGINE COOLANT TEMPERATURE	
POSITIVE CRANKCASE VENTILATION (PCV)		SENSOR CHECK .....	17-101
VALVE CHECK .....	17-90	CRANKSHAFT POSITION SENSOR	
<b>EVAPORATIVE EMISSION CONTROL</b>		CHECK .....	17-102
<b>SYSTEM</b> .....	17-90	<b>EVAPORATIVE EMISSION CANISTER</b>	
GENERAL DESCRIPTION .....	17-90	<b>AND FUEL TANK PRESSURE RELIEF</b>	
COMPONENT LOCATION .....	17-91	<b>VALVE</b> .....	17-102
PURGE CONTROL SYSTEM CHECK		REMOVAL AND INSTALLATION .....	17-102
(PURGE FLOW CHECK) .....	17-92	INSPECTION .....	17-103
EVAPORATIVE EMISSION PURGE		<b>CATALYTIC CONVERTER</b> .....	17-105
SOLENOID CHECK .....	17-93	GENERAL DESCRIPTION	
CHAMBER CHECK .....	17-93	(CATALYTIC CONVERTER) .....	17-105
VOLUME AIR FLOW SENSOR CHECK	17-93	REMOVAL AND INSTALLATION .....	17-105
BAROMETRIC PRESSURE SENSOR		<b>SPECIFICATIONS</b> .....	<b>17-108</b>
CHECK .....	17-94	<b>FASTENER TIGHTENING</b>	
ENGINE COOLANT TEMPERATURE		<b>SPECIFICATIONS</b> .....	17-108
SENSOR CHECK .....	17-94	<b>SERVICE SPECIFICATIONS</b> .....	17-108
INTAKE AIR TEMPERATURE SENSOR			
CHECK .....	17-94		
FUEL TANK DIFFERENTIAL PRESSURE			
SENSOR CHECK .....	17-94		
EVAPORATIVE EMISSION VENTILATION			

## ENGINE CONTROL

### GENERAL DESCRIPTION

A cable-type accelerator mechanical suspended-type pedal has been adopted.

M1171000100084

### ENGINE CONTROL SYSTEM DIAGNOSIS

#### INTRODUCTION TO ENGINE CONTROL SYSTEM DIAGNOSIS

If there is a malfunction in the engine control system, the accelerator cable, accelerator pedal or throttle lever may be faulty.

M1171002000083

#### ENGINE CONTROL SYSTEM DIAGNOSTIC TROUBLESHOOTING STRATEGY

Use these steps to plan your diagnostic strategy. If you follow them carefully, you will be sure that you have exhausted most of the possible ways to find an engine control system fault.

1. Gather information from the customer.

2. Verify that the condition described by the customer exists.

3. Find the malfunction by following the Symptom Chart.

4. Verify that the malfunction is eliminated.

M1171002100109

### SYMPTOM CHART

M1171002200106

SYMPTOMS	INSPECTION PROCEDURE	REFERENCE PAGE
Throttle valve will not fully open or close	1	P.17-3
Accelerator pedal operation not smooth (over acceleration)	2	P.17-4

### SYMPTOM PROCEDURES

#### INSPECTION PROCEDURE 1: Throttle Valve will not Fully Open or Close

##### DIAGNOSIS

##### STEP 1. Check the accelerator cable adjustment.

**Q: Is the accelerator cable properly adjusted?**

**YES :** Go to Step 2.

**NO :** Adjust the accelerator cable by referring to [P.17-4](#), and then go to Step 4.

##### STEP 2. Check the return spring.

**Q: Is the return spring damaged or deformed?**

**YES :** Go to Step 3.

**NO :** Replace, then go to Step 4.

##### STEP 3. Check the throttle lever.

**Q: Is the throttle lever damaged or deformed?**

**YES :** Replace, then go to Step 4.

**NO :** There is no action to be taken.

##### STEP 4. Check symptom.

**Q: Does the throttle valve fully open and close?**

**YES :** This diagnosis is complete.

**NO :** Return to Step 1.

**INSPECTION PROCEDURE 2: Accelerator Pedal Operation is not Smooth (Over Acceleration)****DIAGNOSIS****STEP 1. Check the accelerator pedal.**

- Q: Is the accelerator pedal loose?**  
**YES :** Tighten, then go to Step 4.  
**NO :** Go to Step 2.

**STEP 2. Check the accelerator cable wiring.**

- Q: Is the accelerator cable routing bent sharply?**  
**YES :** Repair, then go to Step 4.  
**NO :** Go to Step 3.

**STEP 3. Check the accelerator cable lubricant.**

- Q: Is the accelerator cable lubricated sufficiently?**  
**YES :** There is no action to be taken.  
**NO :** Refill or replace the lubricant, then go to Step 4.

**STEP 4. Check symptom.**

- Q: Does the accelerator pedal work normally?**  
**YES :** This diagnosis is complete.  
**NO :** Go to Step 1.

**ON-VEHICLE SERVICE****ACCELERATOR CABLE CHECK AND ADJUSTMENT**

M1171000900091

- Turn off air conditioning and all lights.  
Inspect and adjust at no load.
- Start engine and allow to idle unit it reaches normal operating temperature.
- Confirm the idle speed is at standard value.  
**Standard value:**  
**<2.4L ENGINE> 750 ± 100 r/min**  
**<3.0L ENGINE> 700 ± 100 r/min**
- Stop the engine (ignition switch "OFF").
- Confirm there are no sharp bends in the accelerator cable.
- Check the inner cable for correct slack.  
**Standard value: 1 – 2 mm (0.04 – 0.08 inch)**
- If there is too much slack or no slack, adjust the cable as follows:
  - Loosen the adjusting bolt to release the cable.
  - Move the plate until the inner cable play is at the standard value, and then tighten the adjusting bolt.
  - After adjusting, check that the throttle lever is touching the stopper.

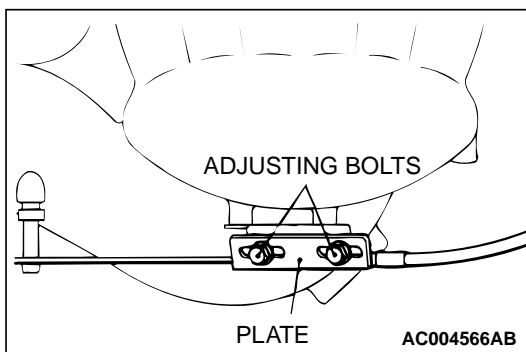

## ACCELERATOR CABLE AND PEDAL REMOVAL AND INSTALLATION

M1171001200103

### Post-installation Operation

Adjusting the Accelerator Cable (Refer to P.17-4.)

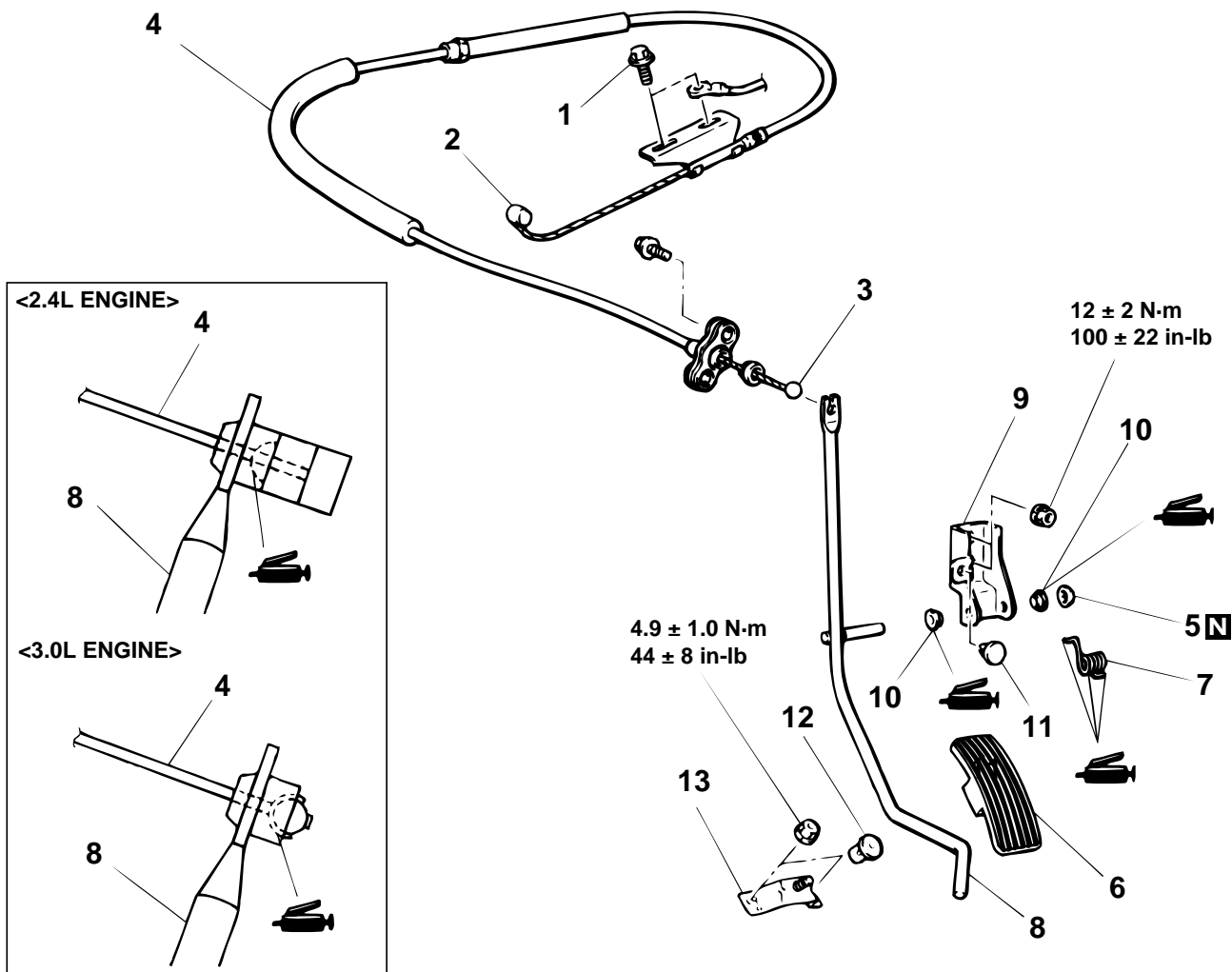

AC005107AB

### REMOVAL STEPS

1. ADJUSTING BOLT
2. INNER CABLE CONNECTION (THROTTLE LEVER SIDE)
3. INNER CABLE CONNECTION (ACCELERATOR PEDAL SIDE)
4. ACCELERATOR CABLE
5. PUSH-ON SPRING NUT
6. PEDAL PAD

### REMOVAL STEPS (Continued)

7. SPRING
8. ACCELERATOR ARM ASSEMBLY
9. ACCELERATOR PEDAL BRACKET
10. BUSHING
11. STOPPER
12. ACCELERATOR PEDAL STOPPER
13. BRACKET

# AUTO-CRUISE CONTROL

## GENERAL DESCRIPTION

M1172000100087

By using the auto-cruise control, the driver can drive at the desired speed [in a range of approximately 40 – 200 km/h (25 – 124 mph)] without depressing the accelerator pedal.

## CONSTRUCTION DIAGRAM

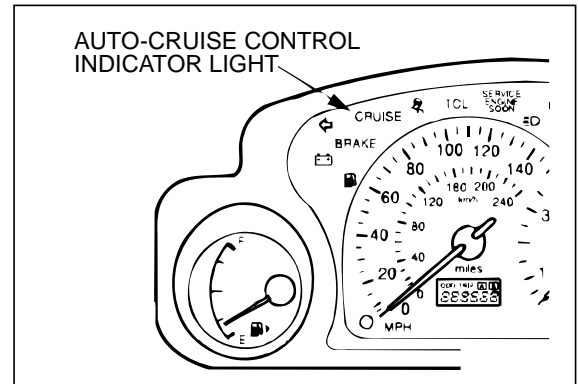
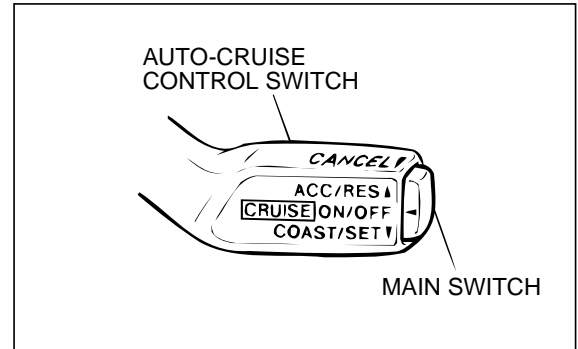
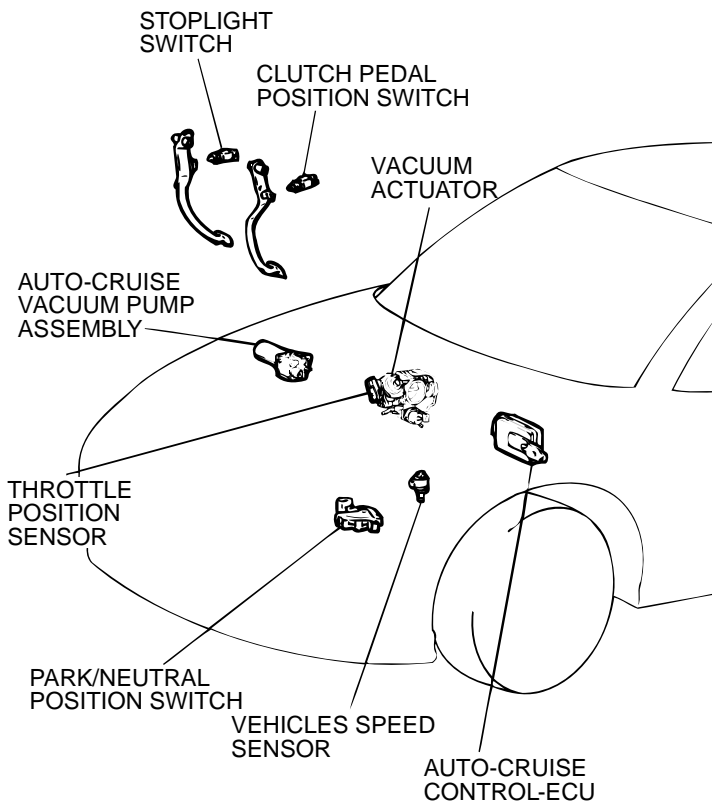

AC001446AB

## SPECIAL TOOLS

M1172000600060

TOOL	TOOL NUMBER AND NAME	SUPERSESION	APPLICATION
B991502	MB991502 Scan tool (MUT-II)	MB991496-OD	Diagnostic trouble code check.
MB991529	MB991529 Diagnostic trouble code check harness	Tool not necessary if scan tool (MUT-II) is available	

TSB Revision

## AUTO-CRUISE CONTROL SYSTEM DIAGNOSIS

### INTRODUCTION TO AUTO-CRUISE CONTROL SYSTEM DIAGNOSIS

M1172003300068

The auto-cruise control system allows driving without stepping on the accelerator pedal by setting a random speed between 40 km/h (25 mph) and 200 km/h (124 mph).

Problems in this system can be investigated by the following methods.

#### Auto-cruise control system diagnostic trouble codes

The auto-cruise control system consists of the auto-cruise control-ECU, control switches, sensors, and vacuum pump.

The control switches and sensors monitor the state of the vehicle.

Based on input signals from those switches and sensors, the auto-cruise control-ECU activates the vacuum pump.

If the auto-cruise control-ECU detects a problem on any of those components, the ECU estimates where the problem may be occurring, and will output a diagnostic trouble code.

Diagnostic trouble codes cover the throttle position sensor, auto-cruise control switch, vehicle speed sensor, auto-cruise control-ECU and vacuum pump.

### AUTO-CRUISE CONTROL SYSTEM DIAGNOSTIC TROUBLESHOOTING STRATEGY

M1172002000064

Use these steps to plan your diagnostic strategy.

If you follow them carefully, you will check most of the possible causes of an auto-cruise control system problem.

1. Gather information from the customer.
2. Verify that the condition described by the customer exists.
3. Check the vehicle for any auto-cruise control system DTC.
4. If you can verify the condition and there are no auto-cruise control system DTCs, and the malfunction is intermittent, refer to GROUP 00, HOW TO USE TROUBLESHOOTING/ INSPECTION SERVICE POINTS - How to Cope with Intermittent Malfunctions [P.00-6](#).
5. If you can verify the condition but there are no auto-cruise control system DTCs, or the system cannot communicate with the scan tool, check that the auto-cruise control system is operating properly.
6. If there is an auto-cruise control system DTC, record the number of the code, then erase the code from vehicle memory using the scan tool.
7. Re-create the auto-cruise control system DTC set conditions to see if the same Auto-cruise Control System DTC will set again.
  - If the auto-cruise control system is operating properly, refer to, Auto-cruise Control System Data List Reference Table.
  - If the auto-cruise control system is operating properly, refer to, Auto-cruise Control System Diagnostic Trouble Code Chart.
  - If the same Auto-cruise Control System DTC sets again, perform the diagnostic procedures for the set code. Refer to, Auto-cruise Control System Diagnostic Trouble Code Chart.

### AUTO-CRUISE CONTROL SYSTEM DIAGNOSTIC TROUBLE CODE DIAGNOSIS

M1172002100061

Retrieving Auto-cruise Control System Diagnostic Trouble Codes.

#### Using scan tool MB991502

##### Required Special Tool:

- MB991502: Scan Tool (MUT-II)

**CAUTION**

To prevent damage to scan tool MB991502, always turn the ignition switch to "LOCK" (OFF) position before connecting or disconnecting scan tool MB991502.

1. Connect scan tool MB991502 to the data link connector.
2. Turn the ignition switch to "ON" position.
3. Use scan tool MB991502 to check for auto-cruise control system diagnostic trouble codes.
4. Turn the ignition switch to "LOCK" (OFF) position.
5. Disconnect scan tool MB991502.

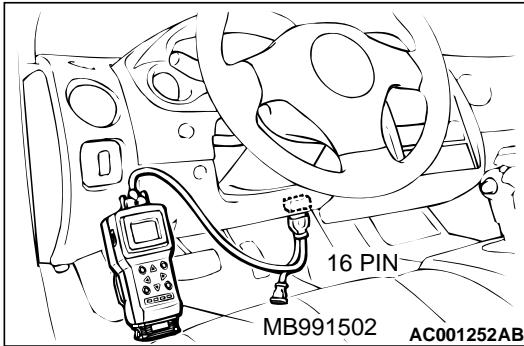

**Using a Auto-cruise Control Indicator Light**

1. Turn the ignition switch to "ON" position while holding the auto-cruise control switch in the "SET" position (down). Then, within one second, move the cruise control switch up to the "RES" position.
2. Read a diagnostic trouble code by observing the flash display pattern of the auto-cruise control indicator light in the combination meter.

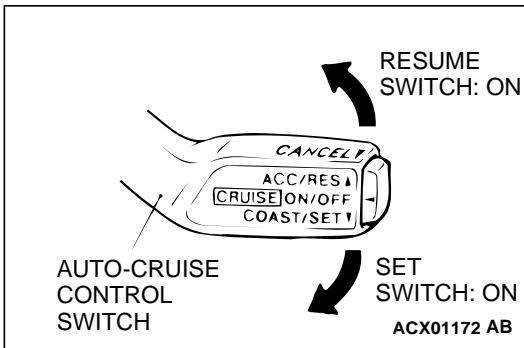

**DIAGNOSTIC RESULT DISPLAY METHOD WHEN USING THE AUTO-CRUISE CONTROL INDICATOR LIGHT**

WHEN THE DIAGNOSTIC TROUBLE CODE NO.14 IS OUTPUT	WHEN NO DIAGNOSTIC TROUBLE CODE IS OUTPUT

NOTE: Other on-board diagnostic items are also output as voltage waveforms corresponding to diagnostic trouble code numbers.



### Erasing Diagnostic Trouble Codes

The diagnostic trouble codes can be erased by the following procedure.

*NOTE: The diagnostic trouble code will not be erased even if the negative battery terminal is disconnected.*

### Using scan tool MB991502

**Required Special Tool:**

- MB991502: Scan Tool (MUT-II)

**CAUTION**

**To prevent damage to scan tool MB991502, always turn the ignition switch to "LOCK" (OFF) position before connecting or disconnecting scan tool MB991502.**

1. Connect scan tool MB991502 to the data link connector.
2. Turn the ignition switch to "ON" position.
3. Use scan tool MB991502 to check for auto-cruise control system diagnostic trouble codes.
4. Turn the ignition switch to "LOCK" (OFF) position.
5. Disconnect scan tool MB991502.

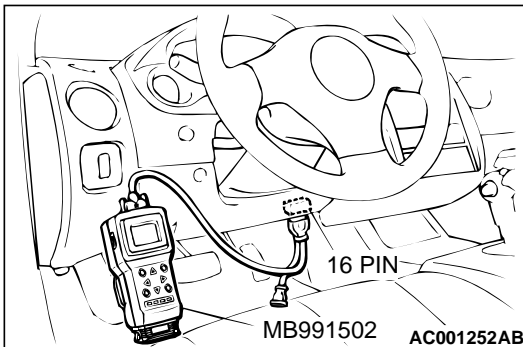

### Without using scan tool MB991502

1. Turn the ignition switch to "ON" position while holding the auto-cruise control switch in the "SET" (down) position. Then, within one second, move the cruise control switch up to the "RES" position.
2. Check to make sure the "CRUISE" light on the instrument panel is flashing.
3. Put the auto-cruise control switch in the "SET" (down) position. Depress the brake pedal and hold for five seconds or more. Release the brake pedal, auto-cruise control switch, then turn the ignition switch to "LOCK" (OFF) position. The DTC(s) are now erased.

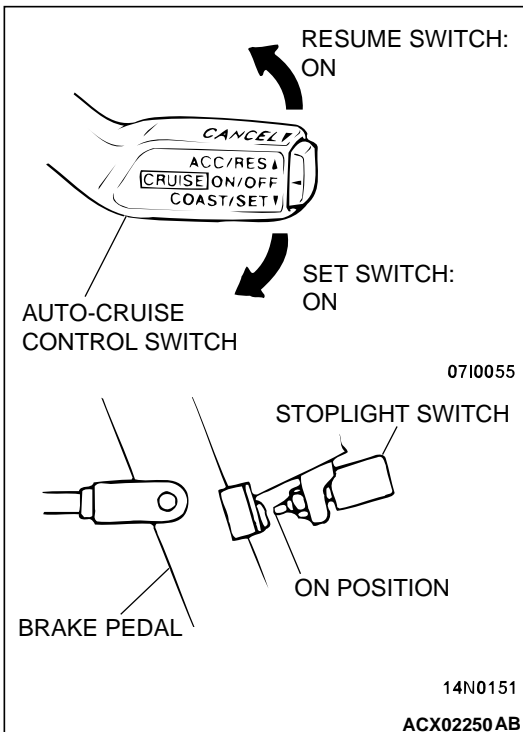

**INSPECTION USING SCAN TOOL MB991502,  
 DATA LIST**

**Required Special Tool:**

- MB991502: Scan Tool (MUT-II)

**⚠ CAUTION**

To prevent damage to scan tool MB991502, always turn the ignition switch to "LOCK" (OFF) position before connecting or disconnecting scan tool MB991502.

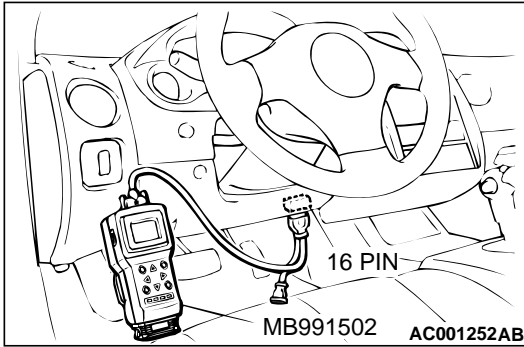

1. Connect scan tool MB991502 to the data link connector.
2. Turn the ignition switch to "ON" position.
3. Carry out inspection by means of the data list.  
 If there is an abnormality, check and repair the chassis harnesses and components. (Refer to P.17-74, Data List Reference Table.)
4. Re-check using scan tool MB991502 and check to be sure that the abnormal input and output have returned to normal because of the repairs.
5. Erase the diagnostic trouble code(s).
6. Turn the ignition switch to "LOCK" (OFF) position.
7. Disconnect scan tool MB991502 from the data link connector.
8. Start the engine again and do a test drive to confirm that the problem is eliminated.

**DIAGNOSTIC TROUBLE CODE CHART**

M1172002200068

Check according to the inspection chart that is appropriate for the diagnostic trouble code.

DIAGNOSTIC TROUBLE CODE NO.	INSPECTION ITEM	REFERENCE PAGE
11	Auto-cruise vacuum pump drive system	P.17-11
12	Vehicle speed sensor system	P.17-16
14	Stoplight switch system	P.17-19
15	Auto-cruise control switch system	P.17-28
16	Auto-cruise control-ECU system	P.17-33
17	Throttle position sensor system	P.17-34

DIAGNOSTIC TROUBLE CODE PROCEDURES

DTC 11: Auto-cruise Vacuum Pump Drive System

Auto-cruise Vacuum Pump Drive System Circuit

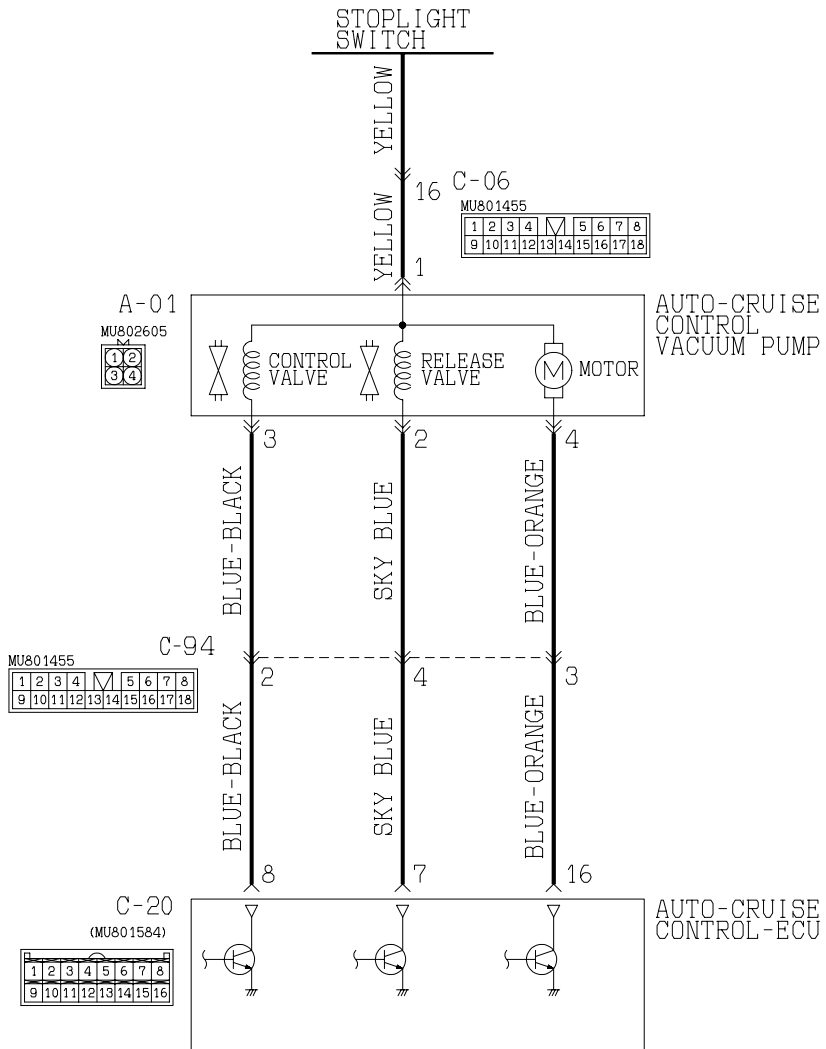

AC005108AB

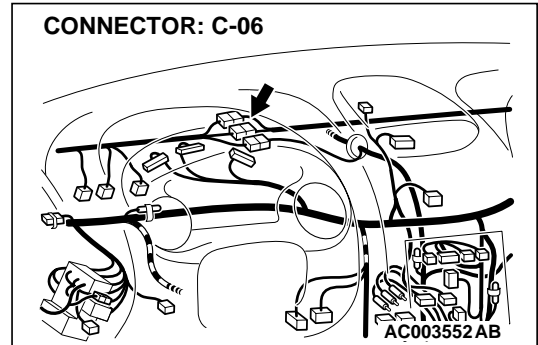
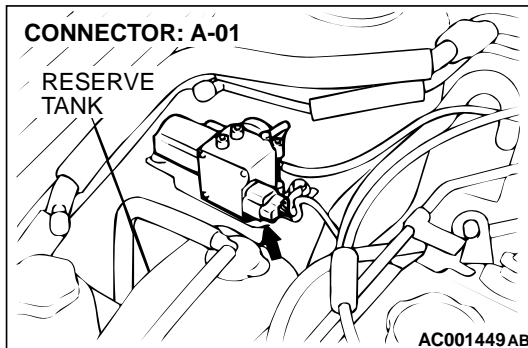

TSB Revision

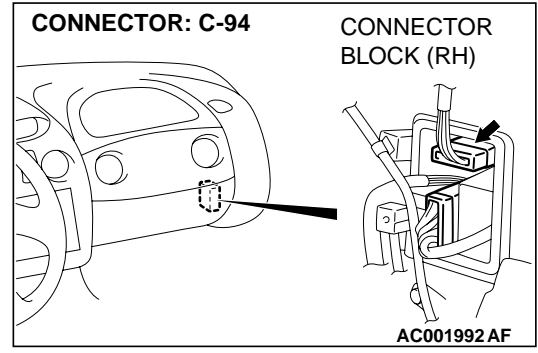
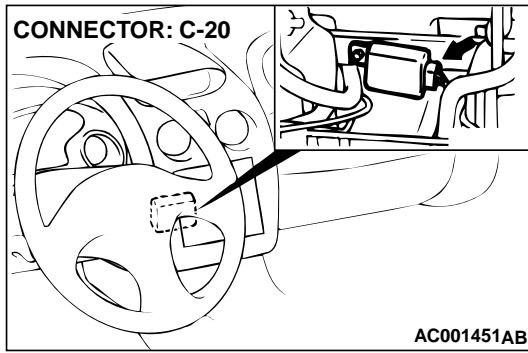

**CIRCUIT OPERATION**

This circuit activates the vacuum pump used to accelerate/decelerate, set, and cancel the vehicle speed.

The auto-cruise control-ECU controls the control valve, release valve, and motor by turning the transistor in the ECU on and off.

**DTC SET CONDITIONS**

Any drive signal for the release valve, control valve or motor is not input to the auto-cruise control-ECU.

**TROUBLESHOOTING HINTS**

- The most likely causes for this code to be set are:
- Malfunction of the auto-cruise vacuum pump.
  - Damaged harness or connector.
  - Malfunction of the auto-cruise control-ECU.

**DIAGNOSIS**

**Required Special Tool:**

- MB991223: Harness Set

**STEP 1. Check the output circuit voltage at auto-cruise control-ECU connector C-20 by backprobing.**

- (1) Do not disconnect auto-cruise control-ECU connector C-20.
- (2) Turn the ignition switch to "ON" position and the auto-cruise control main switch to "ON" position.
- (3) Measure the voltage between terminal 7 and ground by backprobing.
  - Voltage should be battery positive voltage. [When decelerating with the "SET" switch while driving at constant speed (Release valve open).]
- (4) Measure the voltage between terminal 8 and ground by backprobing.
  - Voltage should be battery positive voltage. [When decelerating with the "SET" switch while driving at constant speed. (Control valve open).]
- (5) Measure the voltage between terminal 16 and ground by backprobing.
  - Voltage should be battery positive voltage. (When the motor is stopped during a constant road speed.)
- (6) Turn the ignition switch to "LOCK" (OFF) position.

**Q: Are all of the above values satisfied?**

**YES :** Check that diagnostic trouble code 11 is not output. If diagnostic trouble code 11 is output, replace the auto-cruise control-ECU. (Refer to P.17-81.)

Then check that diagnostic trouble code 11 is not.

**NO :** Go to Step 2.

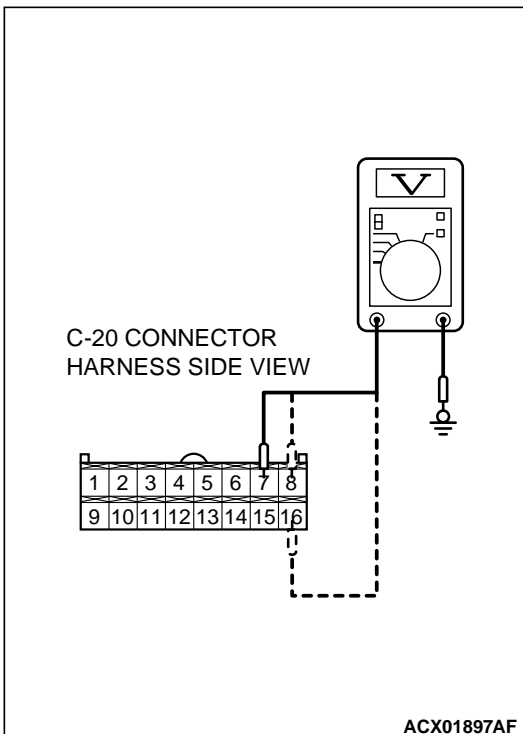

---

**STEP 2. Check auto-cruise control-ECU connector C-20 and intermediate connector C-94.**

**Q: Is the connector damaged?**

**YES :** Repair or replace connector.

Refer to GROUP 00E, Harness Connector Inspection [P.00E-2](#).

Then check that diagnostic trouble code 11 is not output.

**NO :** Go to Step 3.

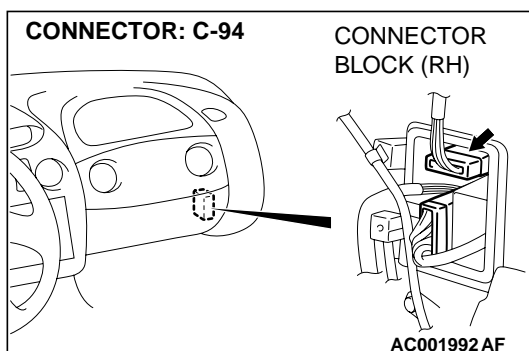
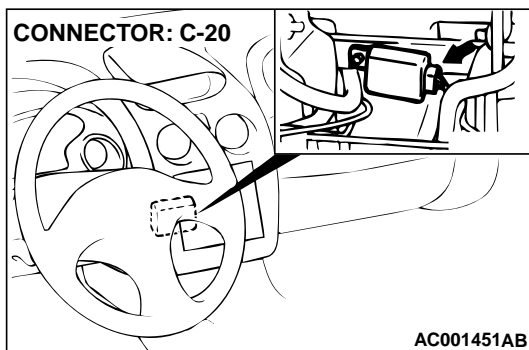

---

**STEP 3. Check auto-cruise control vacuum pump connector A-01.**

**Q: Is the connector damaged?**

**YES :** Repair or replace connector.

Refer to GROUP 00E, Harness Connector Inspection [P.00E-2](#).

Then check that diagnostic trouble code 11 is not output.

**NO :** Go to Step 4.

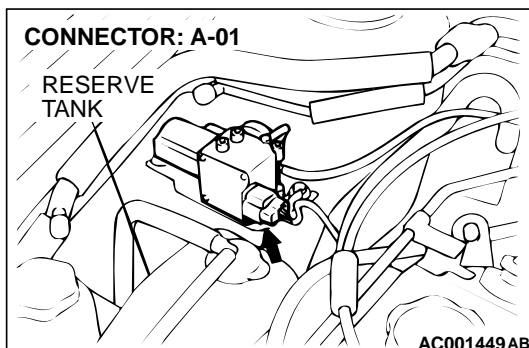

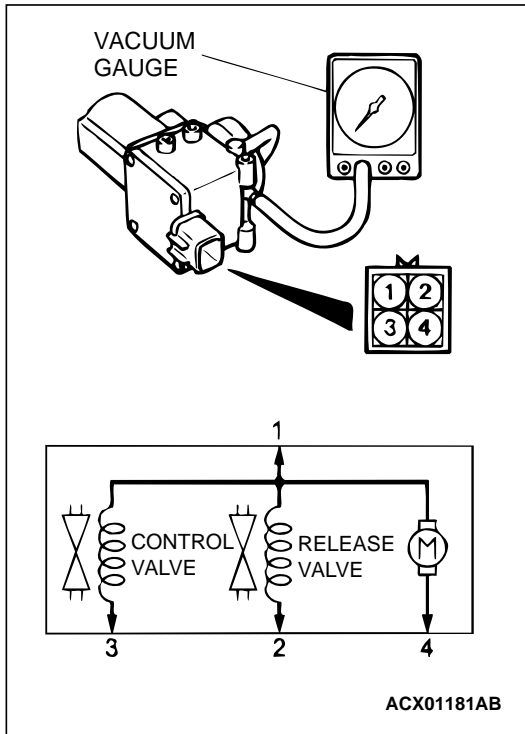
**STEP 4. Check the auto-cruise vacuum pump.**

- (1) Disconnect the vacuum hose from the auto-cruise vacuum pump and connect a vacuum gauge to the vacuum pump.
- (2) Disconnect the vacuum pump connector.
- (3) Check the auto-cruise vacuum pump and valves according to the following procedure:

- Connect the positive battery terminal to auto-cruise vacuum pump connector terminal 1, and the negative battery terminal to terminals 2, 3, and 4. The vacuum gauge should read 27 kPa (8.0 in Hg) or more.
- The vacuum should be maintained when terminal 4 is disconnected from the negative battery terminal while terminals 1, 2, and 3 remain connected. Then the vacuum gauge should read 0 kPa (0 in Hg) when terminal 2 is disconnected from the negative battery terminal while terminals 1, and 3 remain connected.
- The vacuum should be maintained when terminal 4 is disconnected from the negative battery terminal while terminals 1, 2, and 3 remain connected. Then the vacuum gauge should read 0 kPa (0 in Hg) when terminal 3 is disconnected from the negative battery terminal while terminals 1, and 2 remain connected.

**Q: Are all of the above values satisfied?****YES :** Go to Step 5.**No :** Replace the auto-cruise vacuum pump. (Refer to [P.17-81.](#))

Then check that diagnostic trouble code 11 is not output.

**STEP 5. Check the harness wire between auto-cruise control vacuum pump connector A-01 and auto-cruise control-ECU connector C-20.**

**Q: Is any harness wire between auto-cruise control vacuum pump connector A-01 and auto-cruise control-ECU connector C-20 damaged?**

**YES :** Repair the harness wire and then check that diagnostic trouble code 11 is not output.

**NO :** Check that diagnostic trouble code 11 is not output. If diagnostic trouble code 11 is output, replace the auto-cruise control-ECU. (Refer to [P.17-81.](#))

Then check that diagnostic trouble code 11 is not output.

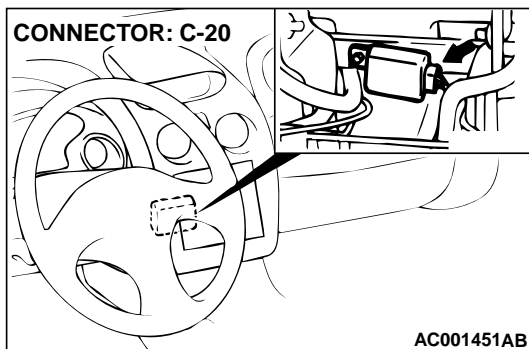
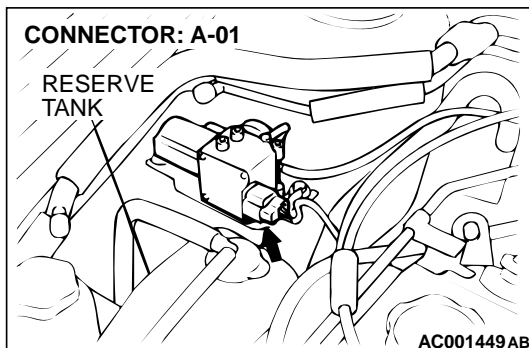

DTC 12: Vehicle Speed Sensor System

Vehicle Speed Sensor System Circuit

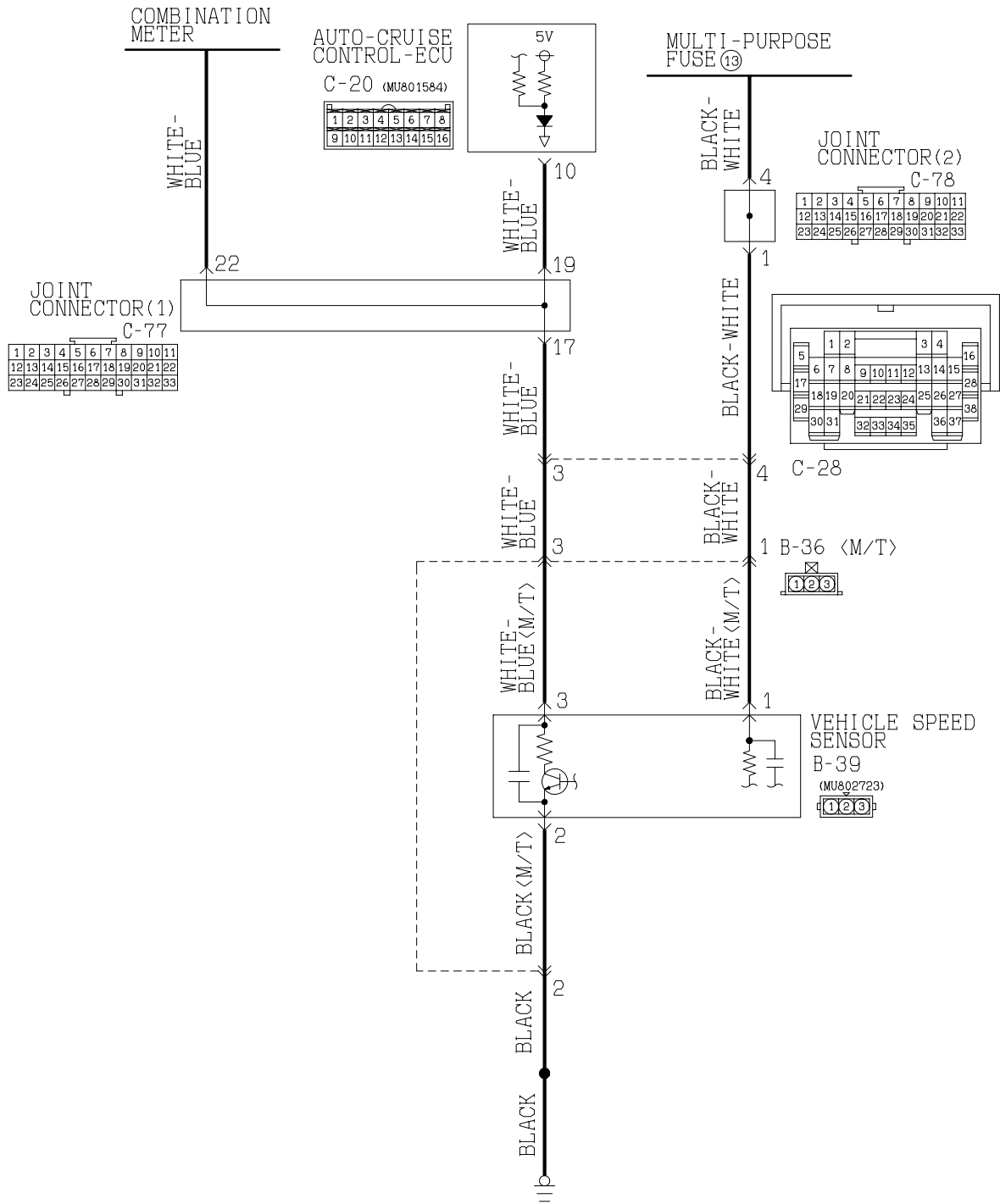

AC005109AB



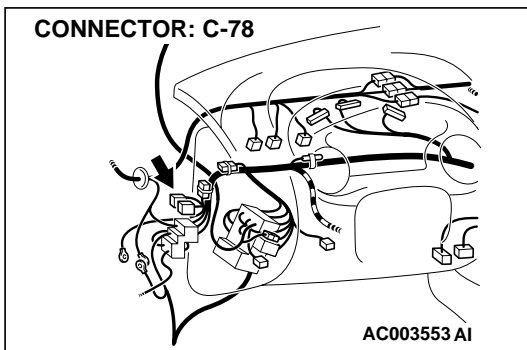
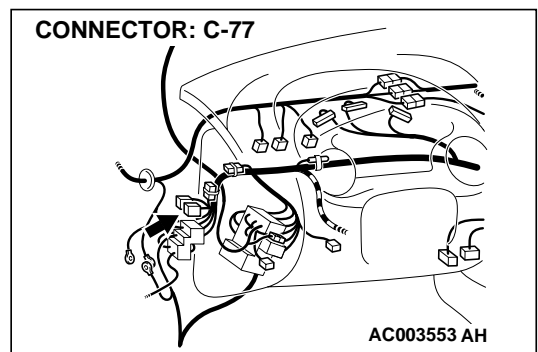
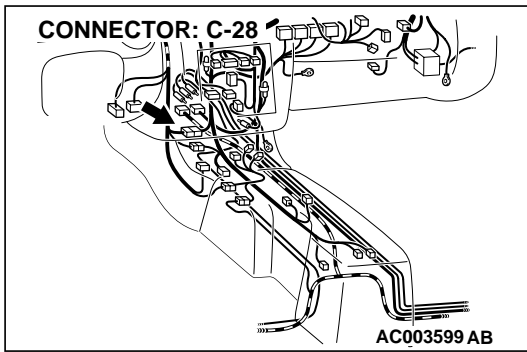
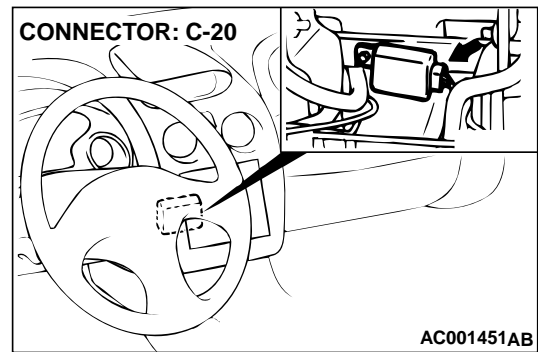
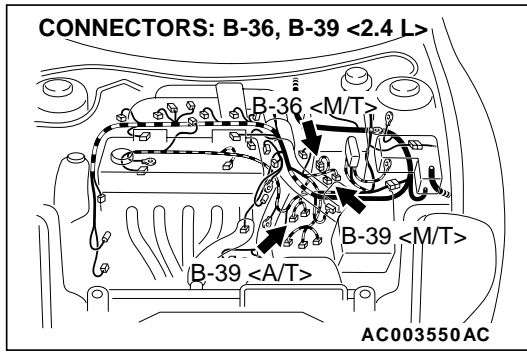

**CIRCUIT OPERATION**

This circuit checks the operation of the vehicle speed sensor.  
 When the vehicle moves forward and reverses, the sensor turns ON and OFF repeatedly.

**DTC SET CONDITIONS**

The vehicle speed signals from the vehicle speed sensor are not input to the auto-cruise control-ECU when the vehicle speed is 40 km/h (25 mph) or more.

**TROUBLESHOOTING HINTS**

The most likely causes for this code to be set are:

- Malfunction of the vehicle speed sensor.
- Damaged harness or connector.
- Malfunction of the auto-cruise control-ECU.

**DIAGNOSIS**

**Required Special Tool:**

- MB991223: Harness Set

**STEP 1. Check the speedometer.****Q: Does the speedometer work normally?****YES :** Go to Step 2.**NO :** Check the speedometer circuit and repair or replace as required.(Refer to GROUP 54A, Combination Meter Assembly and Vehicle Speed Sensor [P.54A-30.](#))**STEP 2. Check joint connector (1) C-77.****Q: Is the connector damaged?****YES :** Repair or replace connector.Refer to GROUP 00E, Harness Connector Inspection [P.00E-2.](#)

Then check that diagnostic trouble code 12 is not output.

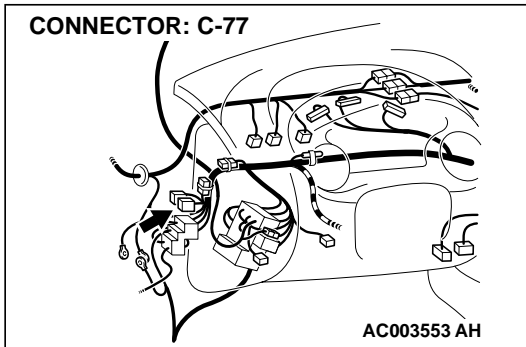
**NO :** Go to Step 3.**STEP 3. Check the harness wire between auto-cruise control-ECU connector C-20 and joint connector (1) C-77.****Q: Is any harness wire between auto-cruise control-ECU connector C-20 and joint connector (1) C-77 damaged?****YES :** Repair the harness wire and then check that diagnostic trouble code 12 is not output.**NO :** Check that diagnostic trouble code 12 is not output. If diagnostic trouble code 12 is output, replace the auto-cruise control-ECU. (Refer to [P.17-81.](#))

Then check that diagnostic trouble code 12 is not output.

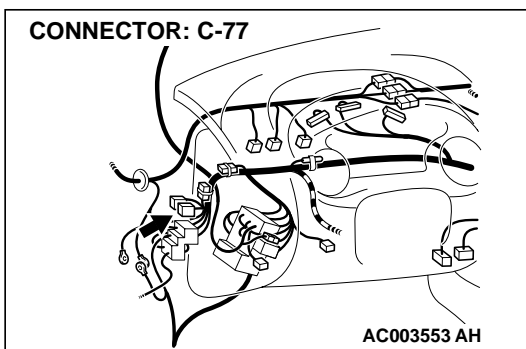
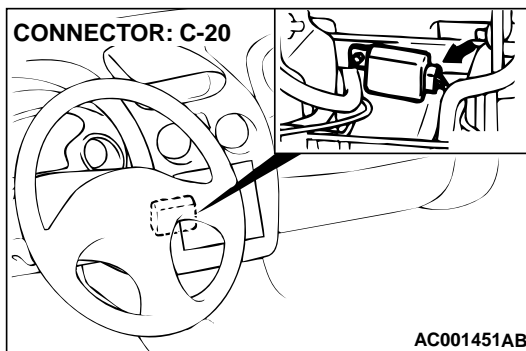

DTC14 : Stoplight Switch System

Stoplight Switch System Circuit

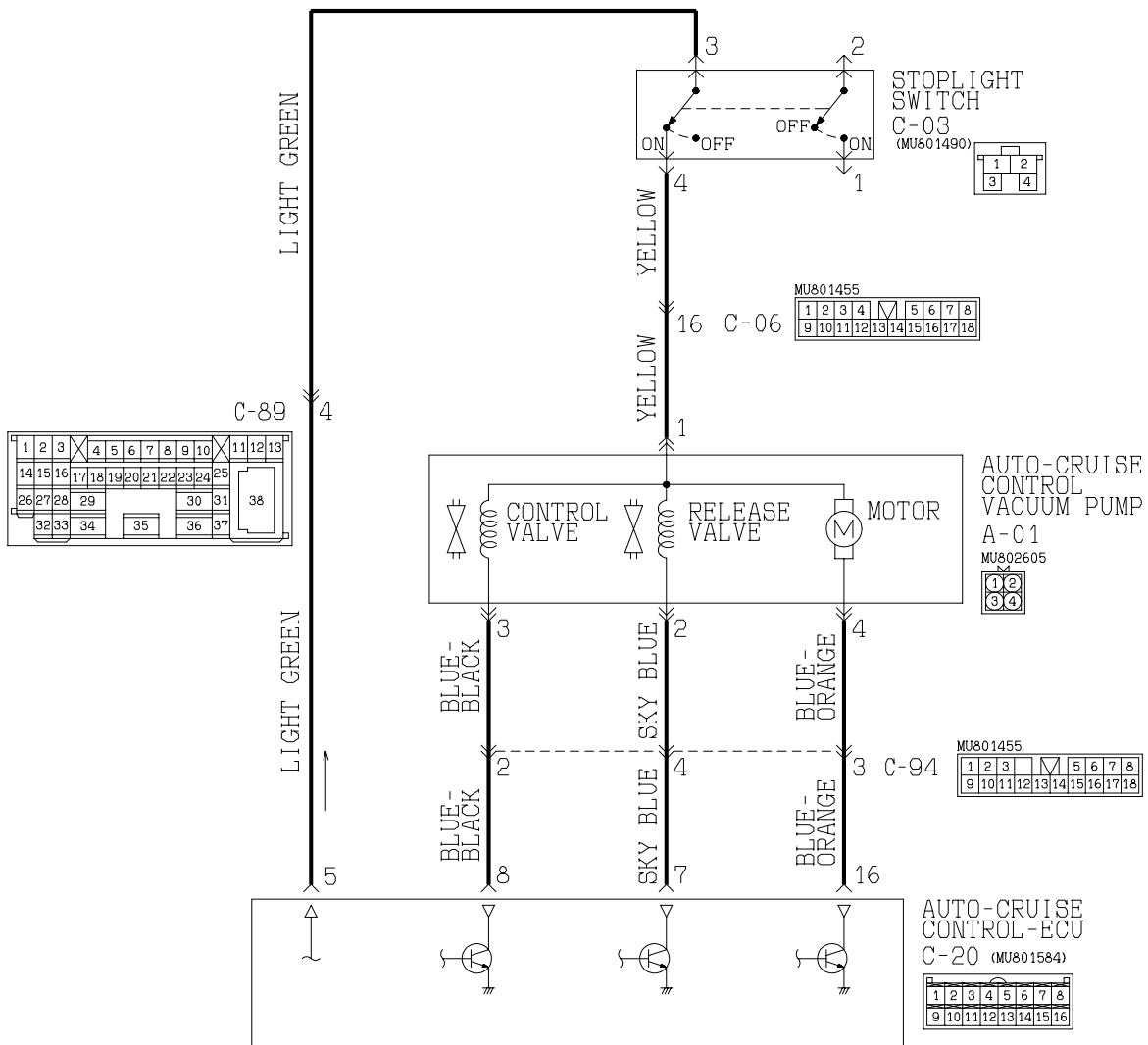

AC005110AB

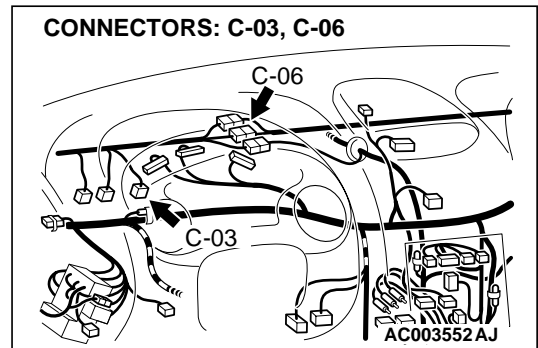
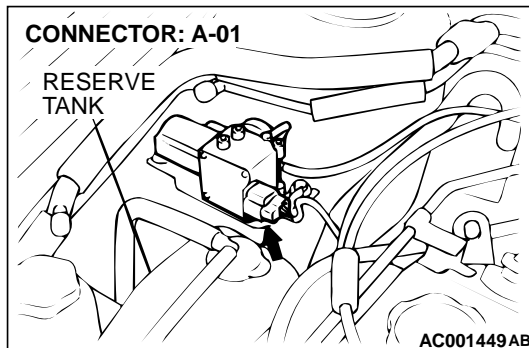

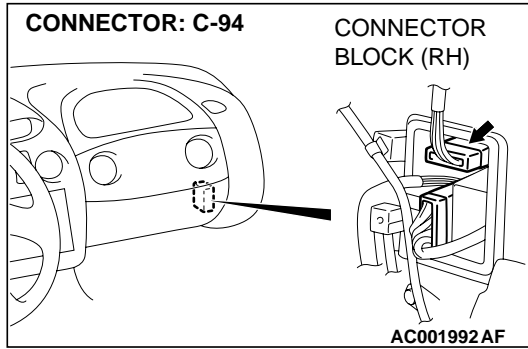
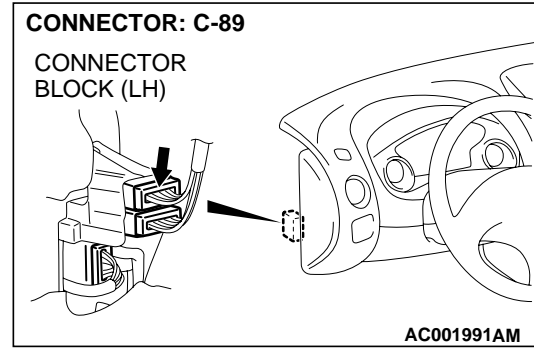
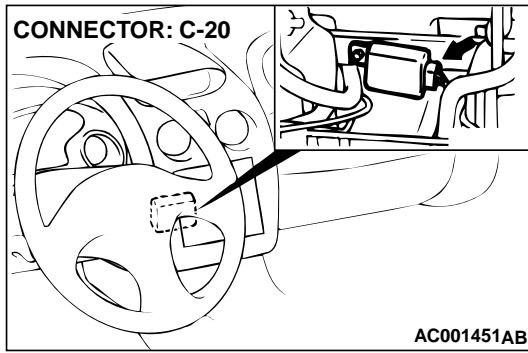

**CIRCUIT OPERATION**

This circuit supplies the power to the vacuum pump. The battery positive voltage is supplied to the auto-cruise control vacuum pump by turning on the transistor at terminal number 16 of the auto-cruise control-ECU.

The conditions for turning on the transistor at terminal number 16 of the auto-cruise control-ECU are as follows.

- Ignition switch "ON"
- Auto-cruise control main switch "ON"
- Stoplight switch ON

**DTC SET CONDITIONS**

None of the drive signals from release valve, control valve and motor of the auto-cruise vacuum pump are input to the auto-cruise control-ECU.

**TROUBLESHOOTING HINTS**

The most likely causes for this code to be set are:

- Malfunction of the stoplight switch
- Malfunction of the auto-cruise vacuum pump
- Damaged harness or connector.
- Malfunction of the auto-cruise control-ECU

**DIAGNOSIS**

**Required Special Tool:**

- MB991223: Harness Set

**STEP 1. Check the output circuit voltage at stoplight switch connector C-03 by backprobing.**

- (1) Do not disconnect stoplight switch connector C-03.
- (2) Turn the ignition switch to "ON" position.
- (3) Measure the voltage between terminal 3 and ground by backprobing.
- (4) Turn the ignition switch to "LOCK" (OFF) position.

**Q: Is the voltage approximately battery positive voltage?**

- YES :** Go to Step 3.
- NO :** Go to Step 2.

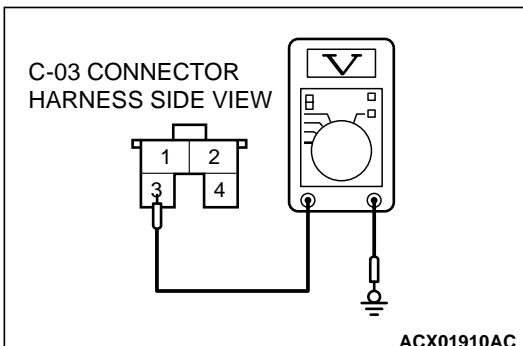

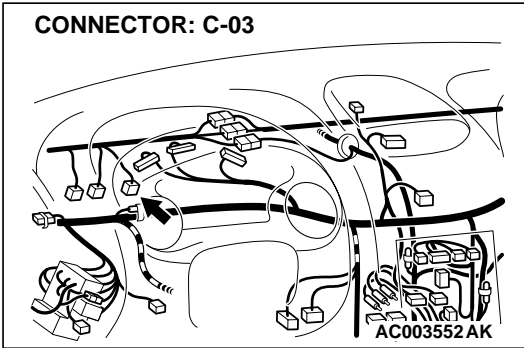

**STEP 2. Check stoplight switch connector C-03.**

**Q: Is the connector damaged?**

**YES :** Repair or replace connector.

Refer to GROUP 00E, Harness Connector Inspection

[P.00E-2.](#)

Then check that diagnostic trouble code 14 is not output.

**NO :** Go to Step 13.

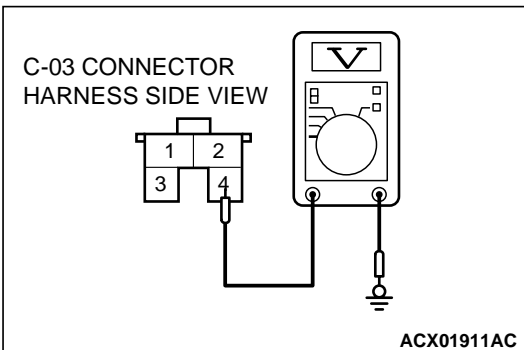

**STEP 3. Check the output circuit voltage at stoplight switch connector C-03 by backprobing.**

(1) Do not disconnect stoplight switch connector C-03.

(2) Turn the ignition switch to "ON" position and the auto-cruise control main switch to "ON" position.

(3) Measure the voltage between terminal 4 and ground by backprobing.

(4) Turn the ignition switch to "LOCK" (OFF) position.

**Q: Is the voltage approximately battery positive voltage?**

**YES :** Go to Step 6.

**NO :** Go to Step 4.

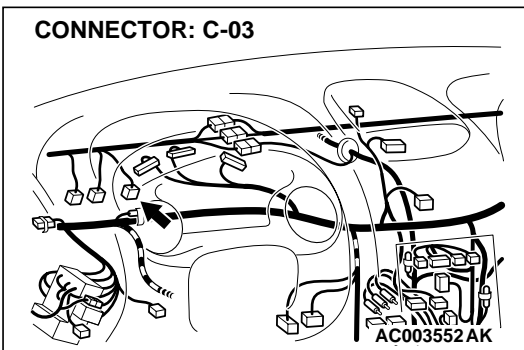

**STEP 4. Check stoplight switch connector C-03.**

**Q: Is the connector damaged?**

**YES :** Repair or replace connector.

Refer to GROUP 00E, Harness Connector Inspection

[P.00E-2.](#)

Then check that diagnostic trouble code 14 is not output.

**NO :** Go to Step 5.

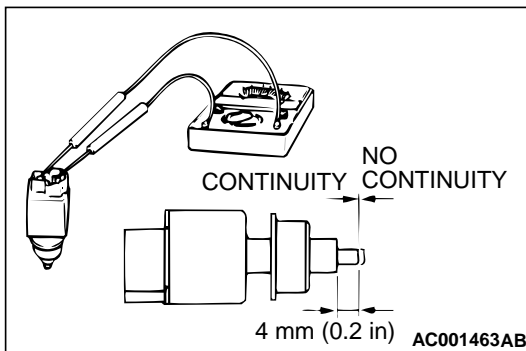
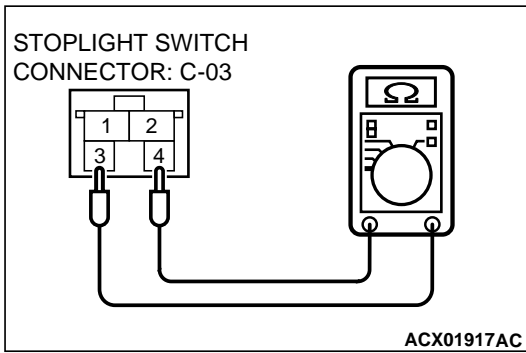

**STEP 5. Check the stoplight switch.**

- (1) Disconnect stoplight switch connector C-03.
- (2) Connect an ohmmeter to the stoplight switch between terminals 3 and 4, and check whether there is continuity when the plunger of the stoplight switch is pushed in and an open circuit when it is released.
- (3) The stoplight switch is in good condition if the circuit is open when the plunger is pushed in to a depth of within 4 mm (0.2 inch) from the outer case edge surface, and if there is continuity when it is released.

**Q: Is the circuit is open?**

**YES :** Replace the stoplight switch.

Refer to GROUP 35A, Brake Pedal [P.35A-31](#).

Then check that a diagnostic trouble code 14 is not output.

**NO :** Check that diagnostic trouble code 14 is not output.

If diagnostic trouble code 14 is output, replace the auto-cruise control-ECU. (Refer to [P.17-81](#).)

Then check that diagnostic trouble code 14 is not output.

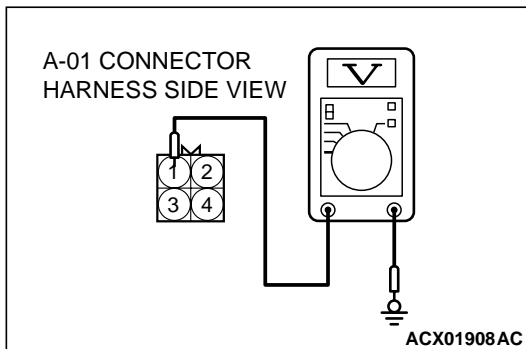

**STEP 6. Check the output circuit voltage at auto-cruise control vacuum pump connector A-01 by backprobing.**

- (1) Do not disconnect auto-cruise control vacuum pump connector A-01.
- (2) Turn the ignition switch to "ON" position and the auto-cruise control main switch to "ON" position.
- (3) Measure the voltage between terminal 1 and ground by backprobing.
- (4) Turn the ignition switch to "LOCK" (OFF) position.

**Q: Is the voltage approximately battery positive voltage?**

**YES :** Go to Step 8.

**NO :** Go to Step 7.

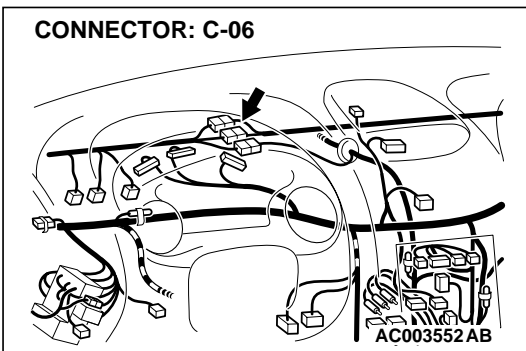
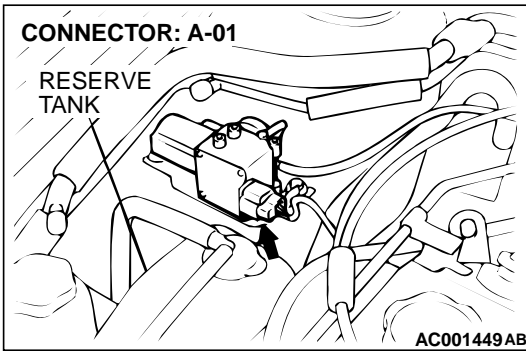

**STEP 7. Check auto-cruise control vacuum pump connector A-01 and intermediate connector C-06.**

**Q: Is any connector damaged?**

**YES :** Repair or replace connector.

Refer to GROUP 00E, Harness Connector Inspection [P.00E-2](#).

Then check that diagnostic trouble code 14 is not output.

**NO :** Check the harness wire between stoplight switch connector C-03 and auto-cruise control vacuum pump connector A-01 for open circuit or damage.

Then repair if necessary.

Then check that diagnostic trouble code 14 is not output.

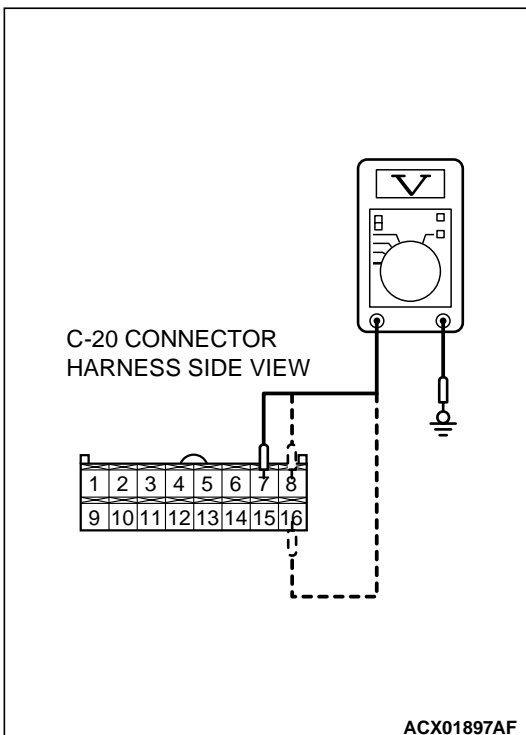

**STEP 8. Check the output circuit voltage at auto-cruise control-ECU connector C-20 by backprobing.**

(1) Do not disconnect auto-cruise control-ECU connector C-20.

(2) Turn the ignition switch to "ON" position and the auto-cruise control main switch to "ON" position.

(3) Measure the voltage between terminal 7 and ground by backprobing.

- Voltage should be battery positive voltage.

[When decelerating with the "SET" switch while driving at constant speed (Release valve open).]

(4) Measure the voltage between terminal 8 and ground by backprobing.

- Voltage should be battery positive voltage.

[When decelerating with the "SET" switch while driving at constant speed. (Control valve open).]

(5) Measure the voltage between terminal 16 and ground by backprobing.

- Voltage should be battery positive voltage.

(When the motor is stopped during a constant road speed.)

(6) Turn the ignition switch to "LOCK" (OFF) position.

**Q: Are all of the above values satisfied?**

**YES :** Check that diagnostic trouble code 14 is not output.

If diagnostic trouble code 14 is output, replace the auto-cruise control-ECU. (Refer to [P.17-81](#).)

Then check that diagnostic trouble code 14 is not.

**NO :** Go to Step 9.

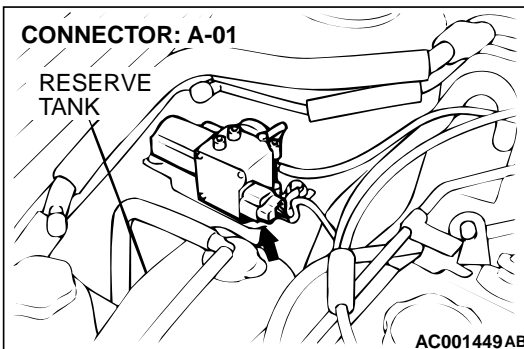
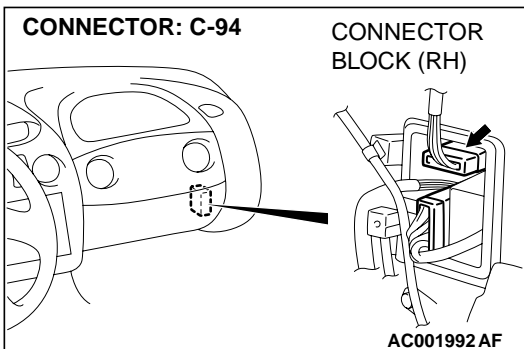
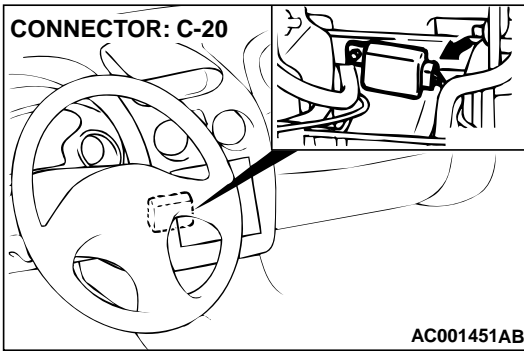

**STEP 9. Check auto-cruise control-ECU connector C-20 and intermediate connector C-94.**

**Q: Is the connector damaged?**

**YES :** Repair or replace connector.

Refer to GROUP 00E, Harness Connector Inspection [P.00E-2](#).

Then check that diagnostic trouble code 14 is not output.

**NO :** Go to Step 10.

**STEP 10. Check auto-cruise control vacuum pump connector A-01.**

**Q: Is the connector damaged?**

**YES :** Repair or replace connector.

Refer to GROUP 00E, Harness Connector Inspection [P.00E-2](#).

Then check that diagnostic trouble code 14 is not output.

**NO :** Go to Step 11.



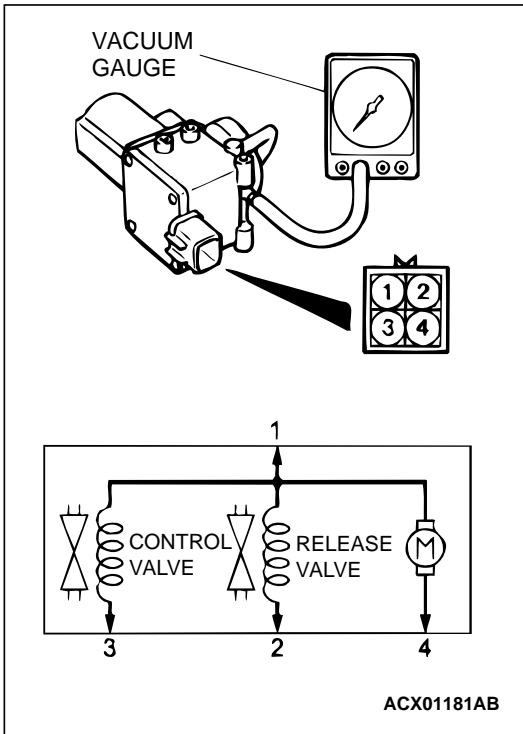

**STEP 11. Check the auto-cruise vacuum pump.**

- (1) Disconnect the vacuum hose from the auto-cruise vacuum pump and connect a vacuum gauge to the vacuum pump.
- (2) Disconnect the vacuum pump connector.
- (3) Check the auto-cruise vacuum pump and valves according to the following procedure:

- Connect the positive battery terminal to auto-cruise vacuum pump connector terminal 1, and the negative battery terminal to terminals 2, 3, and 4. The vacuum gauge should read 27 kPa (8.0 in Hg) or more.
- The vacuum should be maintained when terminal 4 is disconnected from the negative battery terminal while terminals 1, 2, and 3 remain connected. Then the vacuum gauge should read 0 kPa (0 in Hg) when terminal 2 is disconnected from the negative battery terminal while terminals 1, and 3 remain connected.
- The vacuum should be maintained when terminal 4 is disconnected from the negative battery terminal while terminals 1, 2, and 3 remain connected. Then the vacuum gauge should read 0 kPa (0 in Hg) when terminal 3 is disconnected from the negative battery terminal while terminals 1, and 2 remain connected.

**Q: Are all of the above values satisfied?**

**YES :** Go to Step 12.

**NO :** Replace the auto-cruise vacuum pump. (Refer to [P.17-81.](#))

Then check that diagnostic trouble code 14 is not output.

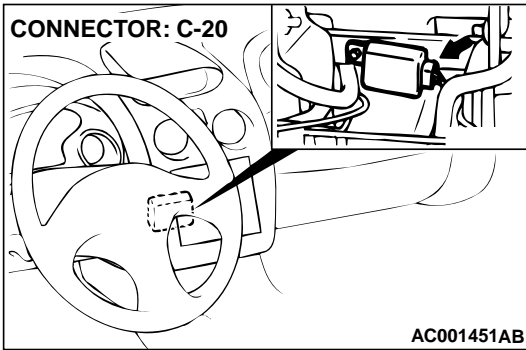
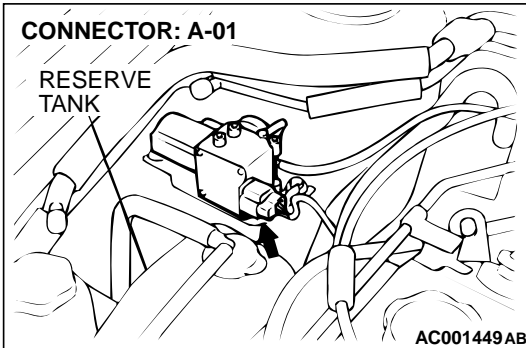

**STEP 12. Check the harness wire between auto-cruise control vacuum pump connector A-01 and auto-cruise control-ECU connector C-20.**

**Q: Is any harness wire between auto-cruise control vacuum pump connector A-01 and auto-cruise control-ECU connector C-20 damaged?**

- YES :** Repair harness wire and then check that diagnostic trouble code 14 is not output.
- NO :** Check that diagnostic trouble code 14 is not output. If diagnostic trouble code 14 is output, replace the auto-cruise control-ECU. (Refer to P.17-81.) Then check that diagnostic trouble code 14 is not output.

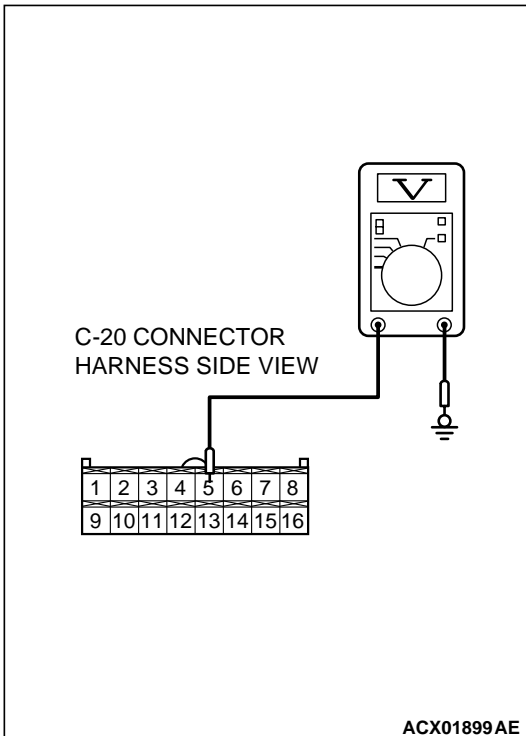

**STEP 13. Check the output circuit voltage at auto-cruise control-ECU connector C-20 by backprobing.**

- (1) Do not disconnect auto-cruise control-ECU connector C-20.
- (2) Turn the ignition switch to "ON" position and the auto-cruise control main switch to "ON" position.
- (3) Measure the voltage between terminal 5 and ground by backprobing.
- (4) Turn the ignition switch to "LOCK" (OFF) position.

**Q: Is the voltage approximately battery positive voltage?**

- YES :** Go to Step 14.
- NO :** Go to Step 15.

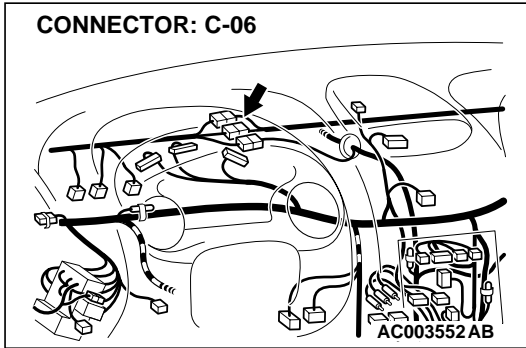

**STEP 14. Check intermediate connector C-06.**

**Q: Is any connector damaged?**

**YES :** Repair or replace connector.

Refer to GROUP 00E, Harness Connector Inspection

[P.00E-2.](#)

Then check that diagnostic trouble code 14 is not output.

**NO :** Check the harness wire between auto-cruise control-ECU connector C-20 and stoplight switch connector C-03 for open circuit or damage.

Then repair if necessary.

Then check that diagnostic trouble code 14 is not output.

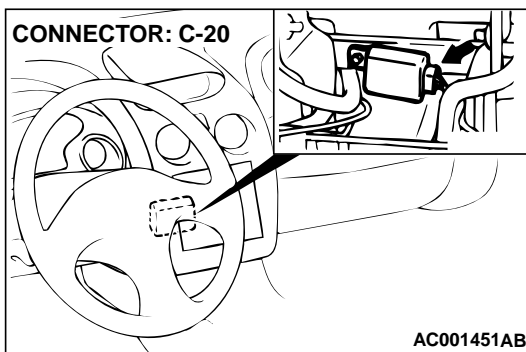

**STEP 15. Check auto-cruise control-ECU connector C-20.**

**Q: Is the connector damaged?**

**YES :** Repair or replace connector.

Refer to GROUP 00E, Harness Connector Inspection

[P.00E-2.](#)

Then check that diagnostic trouble code 14 is not output.

**NO :** Check that diagnostic trouble code 14 is not output. If diagnostic trouble code 14 is output, replace the auto-cruise control-ECU. (Refer to [P.17-81.](#))

Then check that diagnostic trouble code 14 is not output.

DTC15 : Auto-cruise Control Switch System

Auto-cruise Control Switch System Circuit

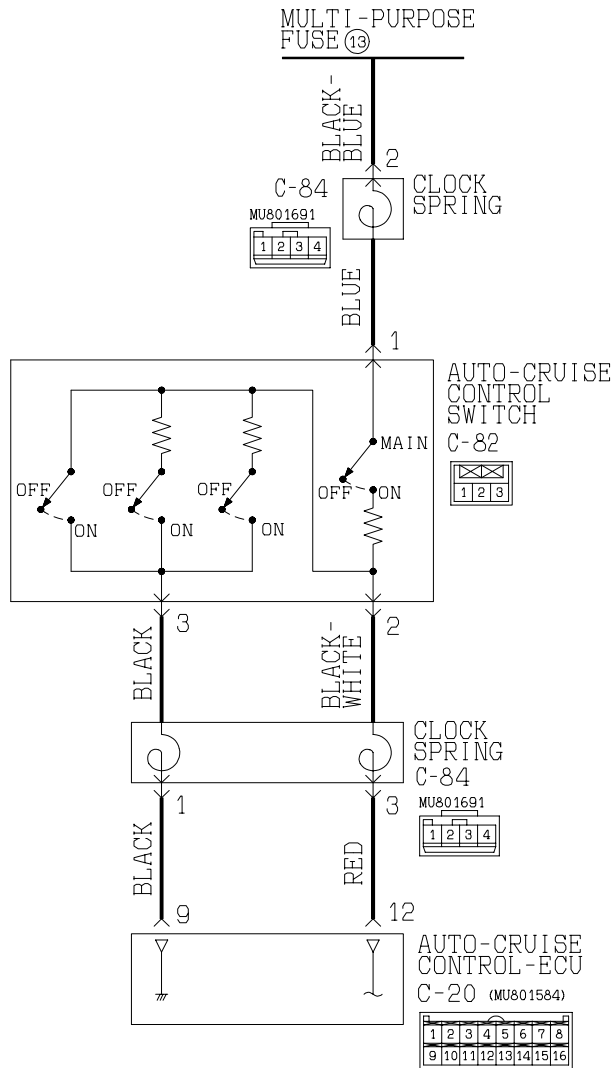

AC005111AB

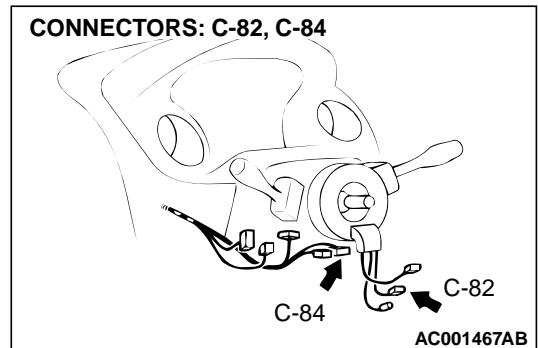
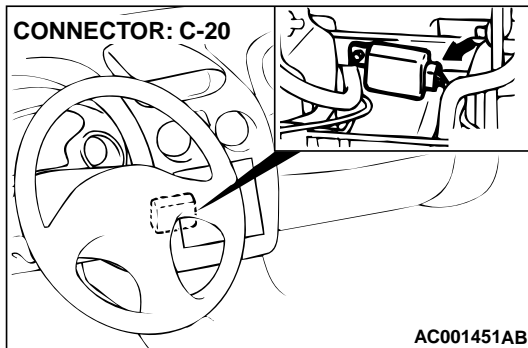

**CIRCUIT OPERATION**

This circuit judges the signals of each switch ("OFF," "SET," "RESUME," "CANCEL" and "MAIN") of the auto-cruise control switch.

The auto-cruise control-ECU detects the state of the auto-cruise control switch by sensing the voltages shown below.

TSB Revision

- When all switches are OFF, the ECU detects 3.5 – 5.0 volts.
- When the "SET" switch is ON, the ECU detects 0.4 – 2.3 volts.
- When the "RESUME" switch is ON, the ECU detects 2.3 – 3.5 volts.
- When the "CANCEL" switch is ON, the ECU detects 0.4 volts or less.
- When the main switch is ON, the ECU detects 7.0 volts.

**DTC SET CONDITIONS**

This code is output when the auto-cruise control switch "RESUME" switch, "SET" switch or "CANCEL" switch stays ON.

**TROUBLESHOOTING HINTS**

The most likely causes for this code to be set are:

- Malfunction of the auto-cruise control switch.
- Malfunction of the clock spring.
- Damaged harness or connector.
- Malfunction of the auto-cruise control-ECU

**DIAGNOSIS**

**Required Special Tool:**

- MB991223: Harness Set

**STEP 1. Check the 12-Volt supply circuit voltage at auto-cruise control switch connector C-82.**

- (1) Disconnect auto-cruise control switch connector C-82 and measure at the harness side.
- (2) Turn the ignition switch to "ON" position.
- (3) Measure the voltage between terminal 1 and ground.
- (4) Turn the ignition switch to "LOCK" (OFF) position.

**Q: Is the voltage approximately battery positive voltage?**

**YES :** Go to Step 5.

**NO :** Go to Step 2.

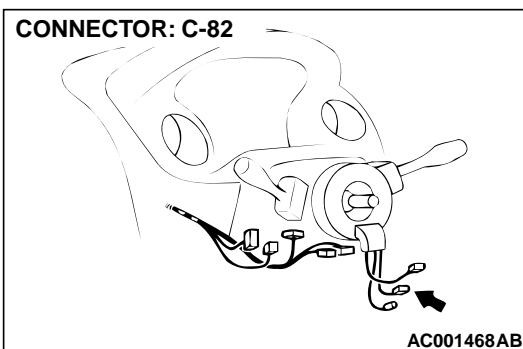
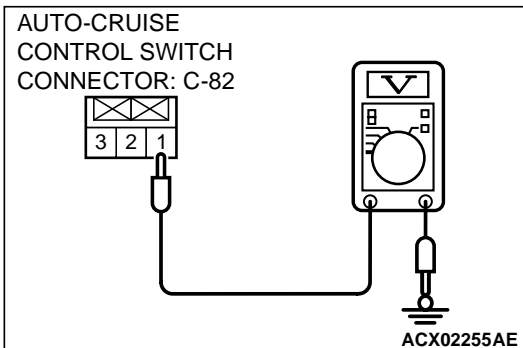

**STEP 2. Check auto-cruise control switch connector C-82.**

**Q: Is the connector damaged?**

**YES :** Repair or replace connector.

Refer to GROUP 00E, Harness Connector Inspection [P.00E-2](#).

Then check that diagnostic trouble code 15 is not output.

**NO :** Go to Step 3.

**STEP 3. Check the clock spring.**

Refer to GROUP 52B, Air Bag Modules and Clock Spring  
[P.52B-69](#).

**Q: Is the clock spring damaged?**

**YES** : Replace the clock spring.

Refer to GROUP 52B, Air Bag Modules and Clock Spring  
[P.52B-69](#).

Then check that diagnostic trouble code 15 is not output.

**NO** : Go to Step 4.

**STEP 4. Check clock spring connector C-84.****Q: Is any connector damaged?**

**YES** : Repair or replace connector.

Refer to GROUP 00E, Harness Connector Inspection  
[P.00E-2](#).

Then check that diagnostic trouble code 15 is not output.

**NO** : Check the harness wire between multi-purpose fuse No.13 and auto-cruise control switch connector C-82 for open circuit or damage.

Then repair if necessary.

Then check that diagnostic trouble code 15 is not output.

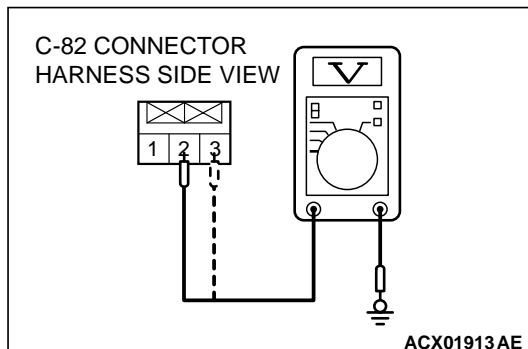
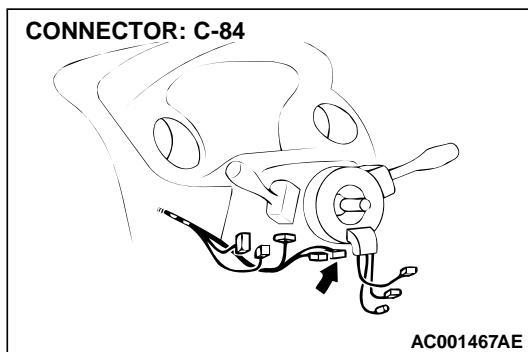
**STEP 5. Check the output circuit voltage at auto-cruise control switch connector C-82 by backprobing.**

(1) Do not disconnect auto-cruise control switch connector C-82.

(2) Turn the ignition switch to "ON" position.

(3) Measure the voltage between terminal 2 and ground by backprobing.

- Voltage should be battery positive voltage.  
(MAIN switch is at the "ON" position.)

(4) Measure the voltage between terminal 3 and ground by backprobing.

- Voltage should be between 6.8 and 7.2 volts.  
(MAIN switch is at the "ON" position.)
- Voltage should be between 3.5 and 5.0 volts.  
(All switches are at the "OFF" position.)
- Voltage should be between 0.4 and 2.3 volts.  
("SET" switch is at the "ON" position)
- Voltage should be between 2.3 and 3.5 volts.  
("RESUME" switch is at the "ON" position.)
- Voltage should be between 1 volt or less.  
("CANCEL" switch is at the "ON" position.)

(5) Turn the ignition switch to "LOCK" (OFF) position.

**Q: Is the voltage within specifications?**

**YES** : Go to Step 8.

**NO** : Go to Step 6.

CONNECTOR: C-82

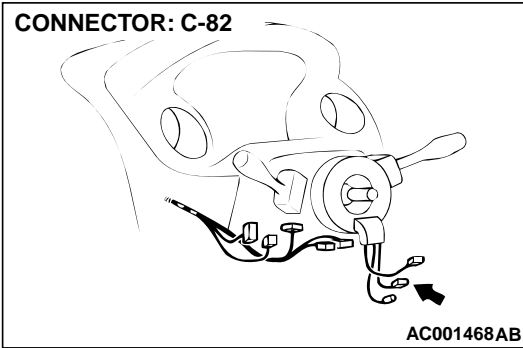

**STEP 6. Check auto-cruise control switch connector C-82.**

**Q: Is the connector damaged?**

**YES :** Repair or replace connector.

Refer to GROUP 00E, Harness Connector Inspection

[P.00E-2.](#)

Then check that diagnostic trouble code 15 is not output.

**NO :** Go to Step 7.

**STEP 7. Check the auto-cruise control switch.**

(1) Disconnect auto-cruise control switch.

(2) Measure the resistance between the terminals when each of the "SET", "RESUME", "CANCEL" and MAIN switch is pressed.

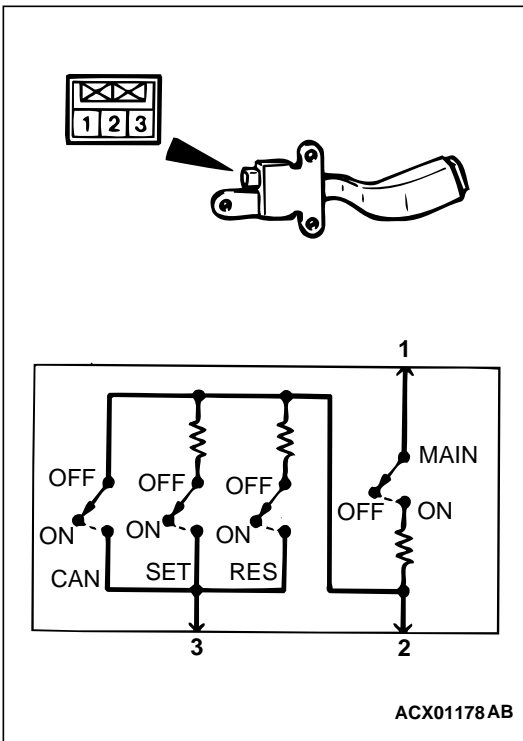

SWITCH POSITION	RESISTANCE BETWEEN TERMINALS	
MAIN switch "OFF"	Terminal 1 and 2	Less than 2 ohm
MAIN switch "ON"	Terminal 1 and 2	Approximately 3.9 kΩ
"CANCEL" switch "ON"	Terminal 2 and 3	Approximately 0 Ω
"RESUME" switch "ON"	Terminal 2 and 3	Approximately 910 Ω
"SET" switch "ON"	Terminal 2 and 3	Approximately 220 Ω

**Q: Is the values measured correspond to those in the table below?**

**YES :** Check that diagnostic trouble code 15 is not output.

If diagnostic trouble code 15 is output, replace the auto-cruise control-ECU. (Refer to [P.17-81.](#))

Then check that diagnostic trouble code 15 is not output.

**NO :** Replace the auto-cruise control switch. (Refer to [P.17-81.](#))

Then check that diagnostic trouble code 15 is not output.

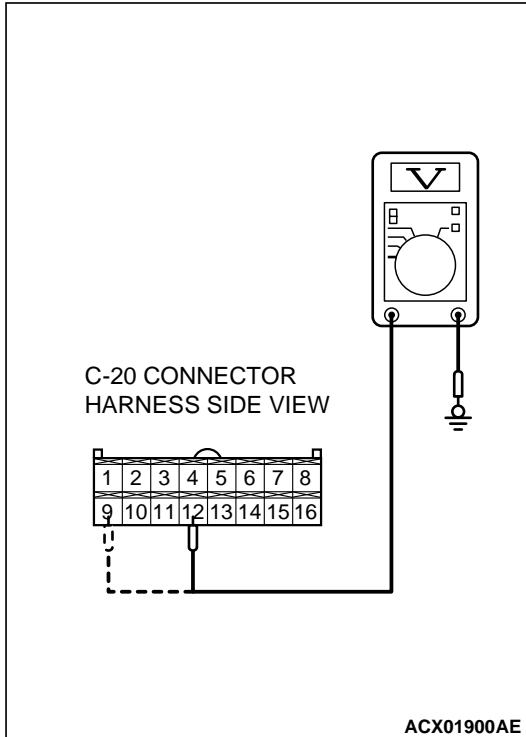
**STEP 8. Check the output circuit voltage at auto-cruise control-ECU connector C-20 by backprobing.**

- (1) Do not disconnect auto-cruise control-ECU connector C-20.
- (2) Turn the ignition switch to "ON" position.
- (3) Measure the voltage between terminal 12 and ground by backprobing.
  - Voltage should be battery positive voltage.  
(The MAIN switch is at the "ON" position.)
- (4) Measure the voltage between terminal 9 and ground by backprobing.
  - Voltage should be between 6.8 and 7.2 volts.  
(MAIN switch is at the "ON" position.)
  - Voltage should be between 3.5 and 5.0 volts.  
(All switches are at the "OFF" position.)
  - Voltage should be between 0.4 and 2.3 volts.  
("SET" switch is at the "ON" position.)
  - Voltage should be between 2.3 and 3.5 volts.  
("RESUME" switch is at the "ON" position.)
  - Voltage should be between 1 volt or less.  
("CANCEL" switch is at the "ON" position.)
- (5) Turn the ignition switch to "LOCK" (OFF) position.

**Q: Is the voltage within specifications?**

**YES :** Check that diagnostic trouble code 15 is not output.  
If diagnostic trouble code 15 is output, replace the auto-cruise control-ECU. (Refer to [P.17-81.](#))  
Then check that diagnostic trouble code 15 is not output.

**NO :** Go to Step 9.

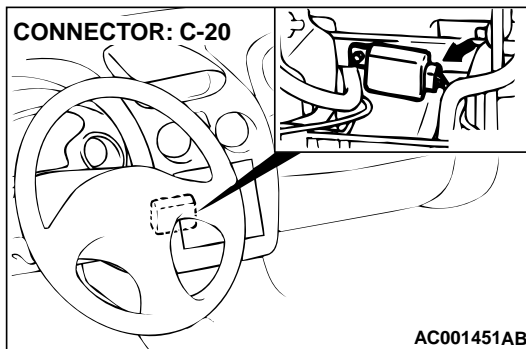
**STEP 9. Check auto-cruise control-ECU connector C-20.****Q: Is the connector damaged?**

**YES :** Repair or replace connector.  
Refer to GROUP 00E, Harness Connector Inspection [P.00E-2.](#)  
Then check that diagnostic trouble code 15 is not output.

**NO :** Go to Step 10.

**STEP 10. Check the clock spring.**

Refer to GROUP 52B, Air Bag Modules and Clock Spring [P.52B-69.](#)

**Q: Is the clock spring damaged?**

**YES :** Replace the clock spring.  
Refer to GROUP 52B, Air Bag Modules and Clock Spring [P.52B-69.](#)  
Then check that diagnostic trouble code 15 is not output.

**NO :** Go to Step 11.



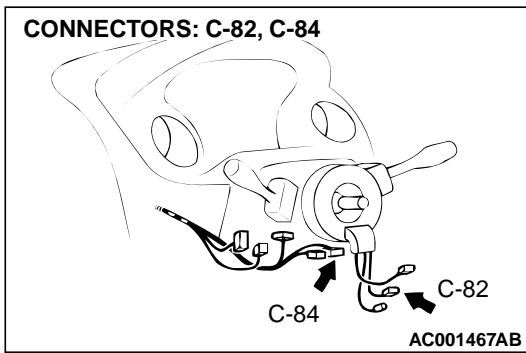

**STEP 11. Check auto-cruise control switch connector C-82, clock spring connector C-84.**

**Q: Is any connector damaged?**

**YES :** Repair or replace connector.

Refer to GROUP 00E, Harness Connector Inspection [P.00E-2](#).

Then check that diagnostic trouble code 15 is not output.

**NO :** Go to Step 12.

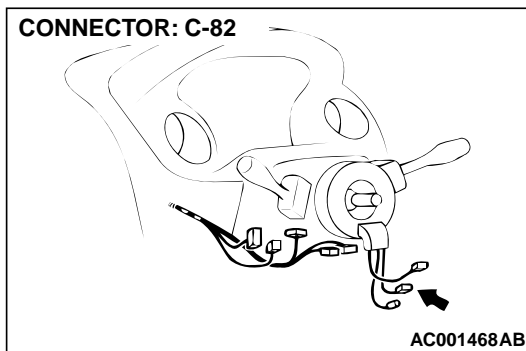

**STEP 12. Check the harness wire between auto-cruise control switch connector C-82 and auto-cruise control-ECU connector C-20.**

**Q: Is any harness wire between auto-cruise control switch connector C-82 and auto-cruise control-ECU connector C-20 damaged?**

**YES :** Repair harness wire and then check that diagnostic trouble code 15 is not output.

**NO :** Check that diagnostic trouble code 15 is not output. If diagnostic trouble code 15 is output, replace the auto-cruise control-ECU. (Refer to [P.17-81](#).) Then check that diagnostic trouble code 15 is not output.

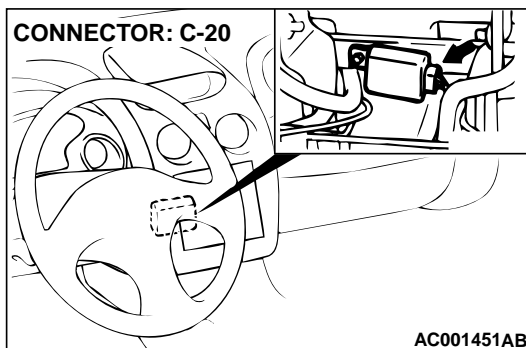

## DTC 16: Auto-cruise Control-ECU

### DTC SET CONDITIONS

This code is output when a problem is found on the cancel status hold circuit or microcomputer operation monitor circuit, which is incorporated in the auto-cruise control-ECU.

### TROUBLESHOOTING HINTS

Malfunction of the auto-cruise control-ECU.

### DIAGNOSIS

Replace the auto-cruise control-ECU. (Refer to [P.17-81](#).)  
 Check that diagnostic trouble code 16 is not output.

DTC 17: Throttle Position Sensor System

Throttle Position Sensor System Circuit

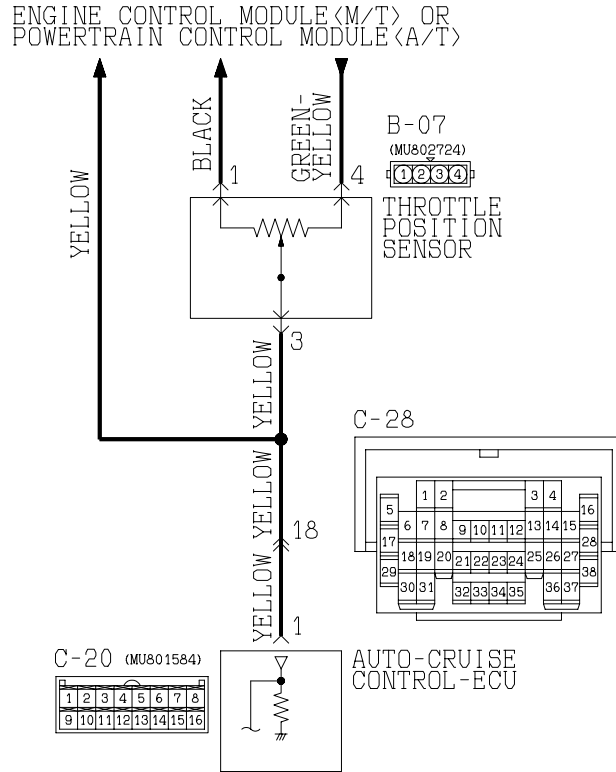

AC005112AB

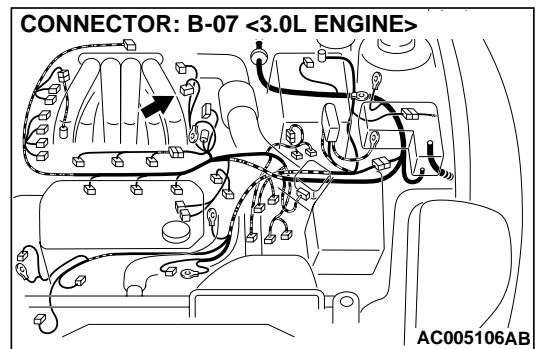
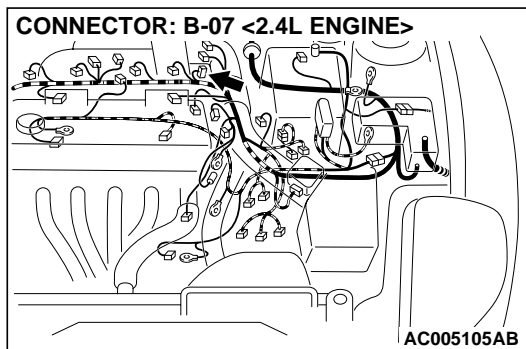

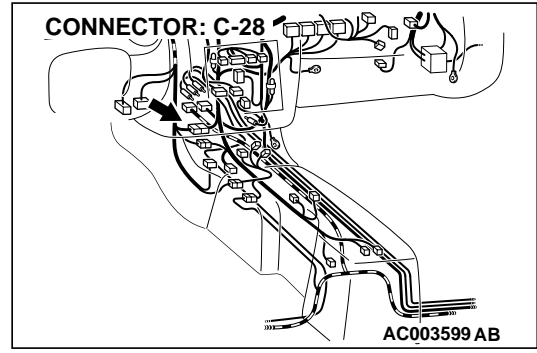
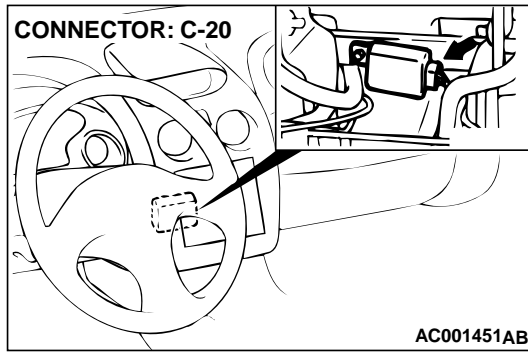

**CIRCUIT OPERATION**

The throttle position sensor signal is sent to the auto-cruise control-ECU through this circuit.

The auto-cruise control-ECU receives a signal from the throttle position sensor at terminal 3.

The signal is OFF when the accelerator pedal is depressed, and ON when the accelerator pedal is released.

The throttle position sensor sends a voltage signal to terminal 1 of the auto-cruise control-ECU.

The voltage depends on throttle opening angle.

**DTC SET CONDITIONS**

If 2.5 volts or more 0.2 volts or less is output for four seconds or more.

**TROUBLESHOOTING HINTS**

The most likely causes for this code to be set are:

- Malfunction of the throttle position sensor.
- Damaged harness or connector.
- Malfunction of the auto-cruise control-ECU.

**DIAGNOSIS**

**Required Special Tools:**

- MB991502: Scan Tool (MUT-II)
- MB991223: Harness Set

**STEP 1. Check the throttle position sensor.**

**⚠ CAUTION**

To prevent damage to scan tool MB991502, always turn the ignition switch to "LOCK" (OFF) position before connecting or disconnecting scan tool MB991502.

- (1) Using scan tool MB991502.
- (2) Connect scan tool MB991502 to the data link connector.
- (3) Turn the ignition switch to "ON" position.
- (4) Read the MFI-DTC.
- (5) Turn the ignition switch to "LOCK" (OFF) position.

**Q: Is the MFI-DTC P0120 is output?**

**YES** : For 2.4L Engine, refer to GROUP 13A, Diagnosis – Diagnostic Trouble Code Chart [P.13A-20](#).

For 3.0L Engine, refer to GROUP 13B, Diagnosis – Diagnostic Trouble Code Chart [P.13B-18](#).

**NO** : Go to Step 2.

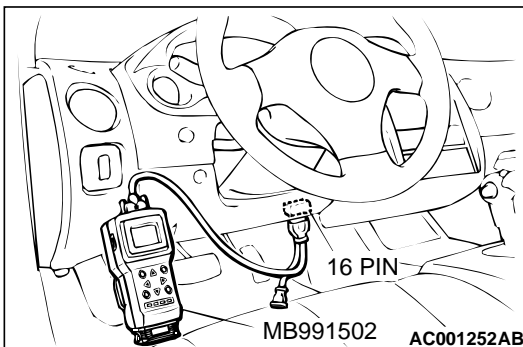

**STEP 2. Check the output circuit voltage at auto-cruise control-ECU connector C-20 by backprobing.**

- (1) Do not disconnect auto-cruise control-ECU connector C-20.
- (2) Turn the ignition switch to "ON" position and the auto-cruise control main switch to "ON" position.
- (3) Measure the voltage between terminal 1 and ground by backprobing.
  - Voltage should be between 4.0 and 5.5 volts. (When accelerator pedal is fully depressed.)
  - Voltage should be between 0.4 and 1.0 volts. (When accelerator pedal is released.)
- (4) Turn the ignition switch to "LOCK" (OFF) position.

**Q: Are the voltage within specifications?**

**YES :** Check that diagnostic trouble code 17 is not output. If diagnostic trouble code 17 is output, replace the auto-cruise control-ECU. (Refer to [P.17-81.](#)) Then check that diagnostic trouble code 17 is not.

**NO :** Go to Step 3.

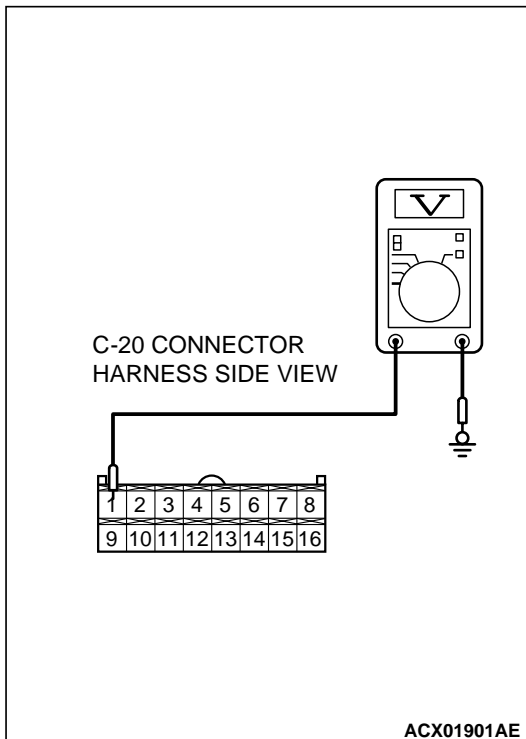
**STEP 3. Check auto-cruise control-ECU connector C-20.****Q: Is the connector damaged?**

**YES :** Repair or replace connector. Refer to GROUP 00E, Harness Connector Inspection [P.00E-2.](#) Then check that diagnostic trouble code 17 is not output.

**NO :** Go to Step 4.

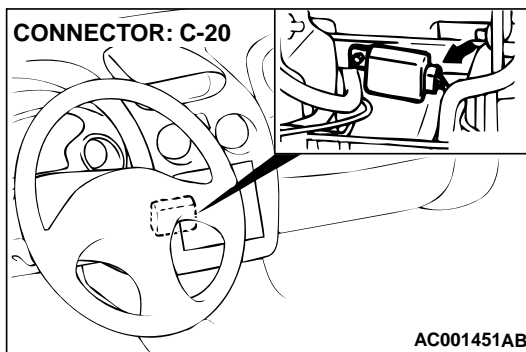

**STEP 4. Check the harness wire between throttle position sensor connector B-07 and auto-cruise control-ECU connector C-20.**

**Q: Is the harness wire between throttle position sensor connector B-07 and auto-cruise control-ECU connector C-20 damaged?**

**YES :** Repair harness wire and then check that diagnostic trouble code 17 is not output.

**NO :** Check that diagnostic trouble code 17 is not output. If diagnostic trouble code 17 is output, replace the auto-cruise control-ECU. (Refer to [P.17-81.](#)) Then check that diagnostic trouble code 17 is not output.

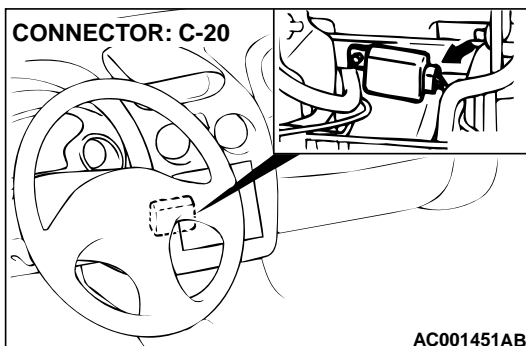
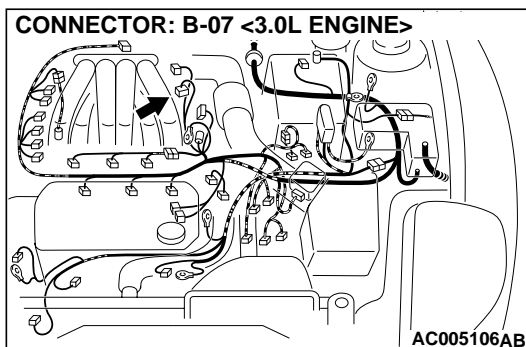
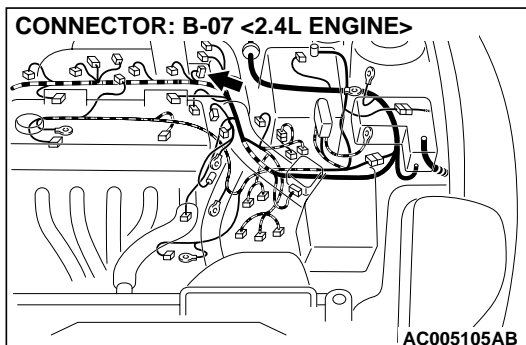

## SYMPTOM CHART

SYMPTOMS		INSPECTION PROCEDURE NO.	REFERENCE PAGE
Communication with scan tool MB991502 is not possible	Communication with all systems is not possible	-	<2.4 L> P.13A-339 <3.0 L> P.13B-411
	Communication with auto-cruise control-ECU only is not possible	1	P.17-39
Auto-cruise control is not cancelled.	When brake pedal is depressed	2	P.17-46
	When clutch pedal is depressed <M/T>	3	P.17-53
	When selector lever is moved to "N" range <A/T>	4	P.17-58
	When "CANCEL" switch is turned ON	5	P.17-62
Auto-cruise control cannot be set.		6	P.17-62
Hunting (repeated acceleration and deceleration) occurs at the set vehicle speed.		7	P.17-65
Auto-cruise control indicator light inside combination meter does not illuminate. (However, auto-cruise control is normal.)		8	P.17-67

**SYMPTOM PROCEDURES**

**INSPECTION PROCEDURE 1: Communication with Scan Tool MB991502 is not Possible  
 (Communication with the Auto-cruise Control-ECU only is not Possible.)**

Auto-cruise Control-ECU Supply, Ground and Data Link Circuit

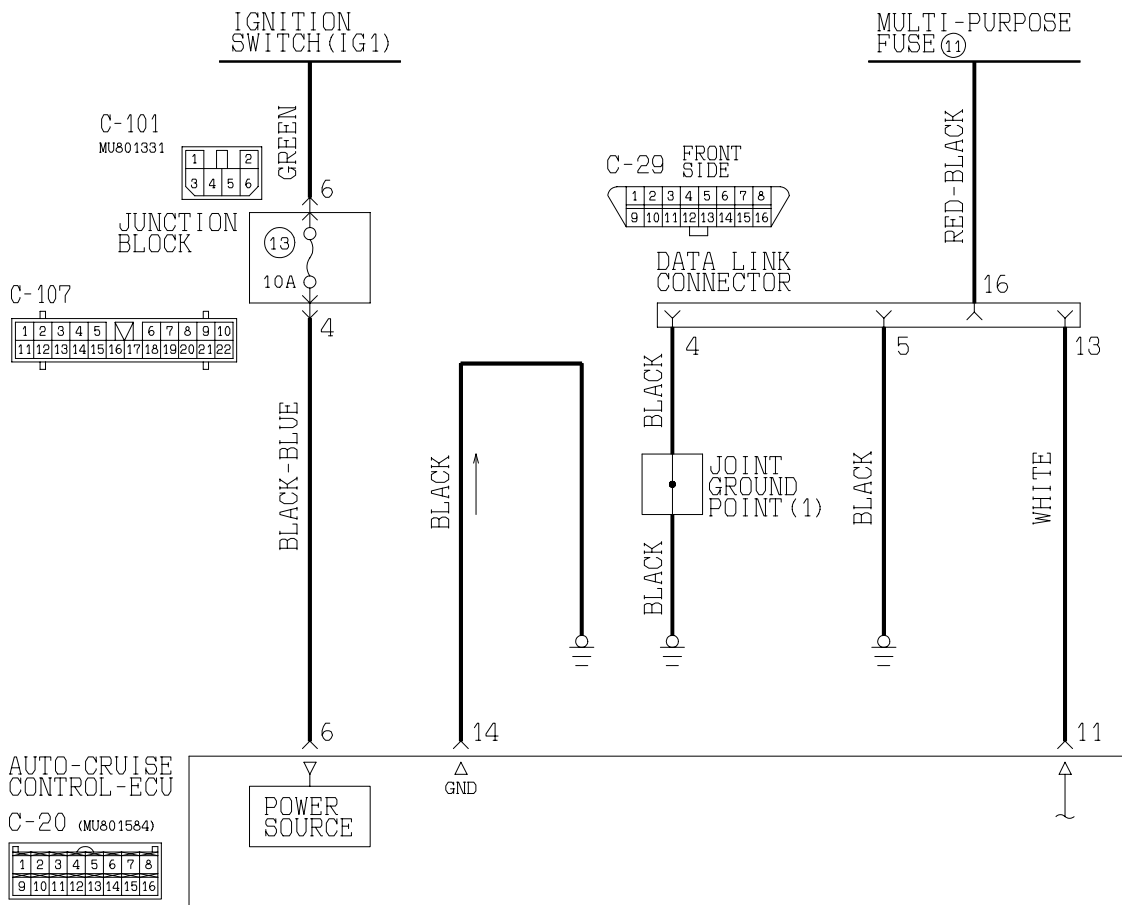

AC005113AB

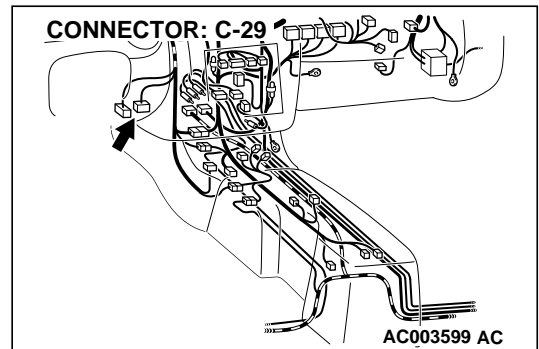
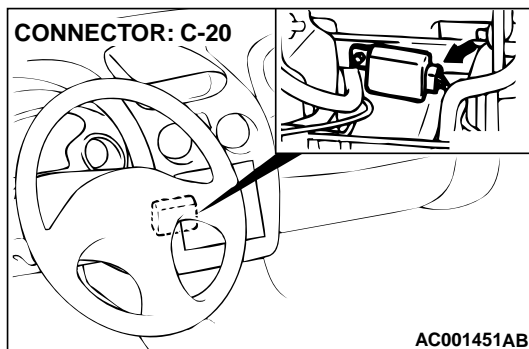

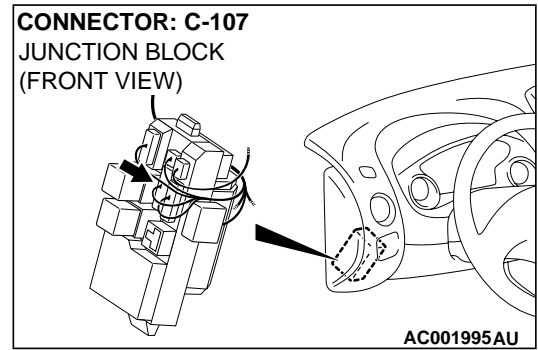
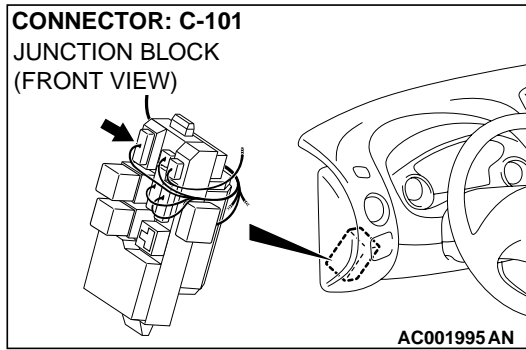

**CIRCUIT OPERATION**

Power of the auto-cruise control-ECU is transmitted from the ignition switch (IG1) to the auto-cruise control-ECU through multi-purpose fuse 13 in the junction block.

**TECHNICAL DESCRIPTION (COMMENT)**

The cause is probably a malfunction of the auto-cruise control-ECU power supply circuit or the auto-cruise control-ECU ground circuit.

**TROUBLESHOOTING HINTS**

- Damaged harness or connector.
- Malfunction of the auto-cruise control-ECU.

**DIAGNOSIS**

**Required Special Tool:**

- MB991223: Harness Set

**STEP 1. Check the output circuit voltage at auto-cruise control-ECU connector C-20 by backprobing.**

- (1) Do not disconnect auto-cruise control switch connector C-20.
- (2) Turn the ignition switch to "ON" position.
- (3) Measure the voltage between terminal 6 and ground by backprobing.
- (4) Turn the ignition switch to "LOCK" (OFF) position.

**Q: Is the voltage approximately battery positive voltage?**

- YES :** Go to Step 5.  
**NO :** Go to Step 2.

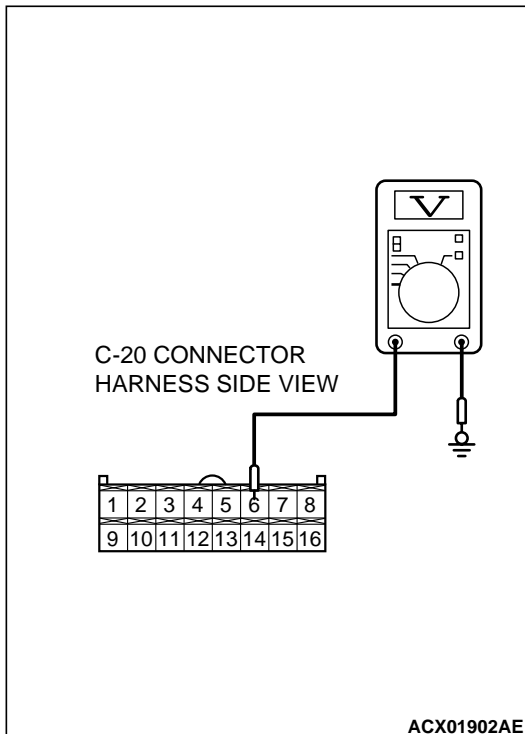



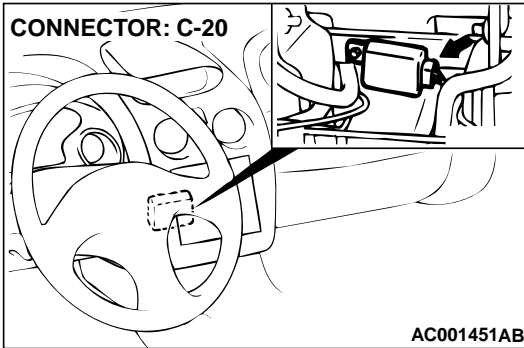

**STEP 2. Check auto-cruise control-ECU connector C-20.**

**Q: Is the connector damaged?**

**YES :** Repair or replace connector.

Refer to GROUP 00E, Harness Connector Inspection

[P.00E-2.](#)

Then check that the malfunction is eliminated.

**NO :** Go to Step 3.

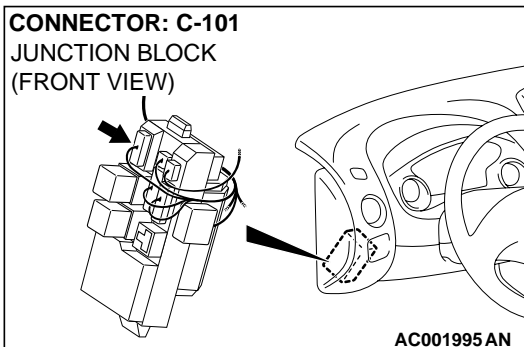

**STEP 3. Check junction block connector C-101 and C-107.**

**Q: Is any connector damaged?**

**YES :** Repair or replace connector.

Refer to GROUP 00E, Harness Connector Inspection

[P.00E-2.](#)

Then check that the malfunction is eliminated.

**NO :** Go to Step 4.

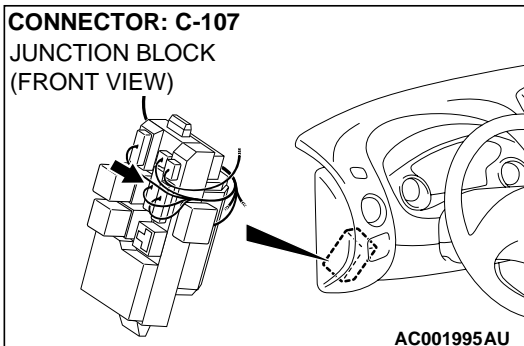

**STEP 4. Check the harness wire between ignition switch and auto-cruise control-ECU connector C-20.**

**Q: Is any harness wire between ignition switch and auto-cruise control-ECU connector C-20 damaged?**

**YES :** Repair the harness wire and then check that the malfunction is eliminated.

**NO :** Check that the malfunction is eliminated.

If the malfunction is eliminated, replace the auto-cruise control-ECU. (Refer to [P.17-81.](#))

Then check that the malfunction is eliminated.

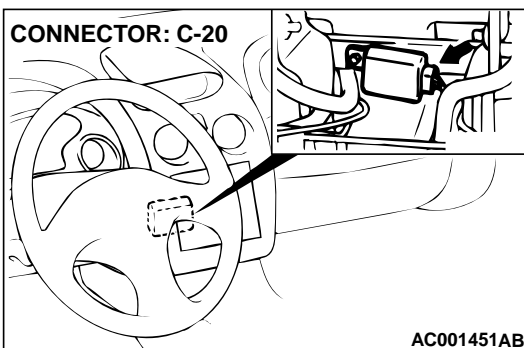

**STEP 5. Check the ground circuit voltage at auto-cruise control-ECU connector C-20 by backprobing.**

- (1) Do not disconnect auto-cruise control switch connector C-20.
- (2) Turn the ignition switch to "ON" position.
- (3) Measure the voltage between terminal 14 and ground by backprobing.
- (4) Turn the ignition switch to "LOCK" (OFF) position.

**Q: Is the voltage approximately 0.5 volts or less?**

**YES :** Go to Step 8.

**NO :** Go to Step 6.

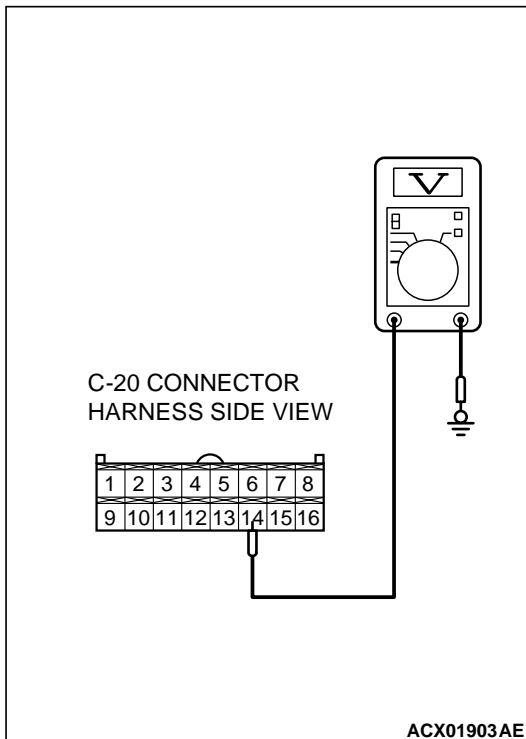
**STEP 6. Check auto-cruise control-ECU connector C-20.**

**Q: Is the connector damaged?**

**YES :** Repair or replace connector.

Refer to GROUP 00E, Harness Connector Inspection  
[P.00E-2](#).

Then check that the malfunction is eliminated.

**NO :** Go to Step 7.

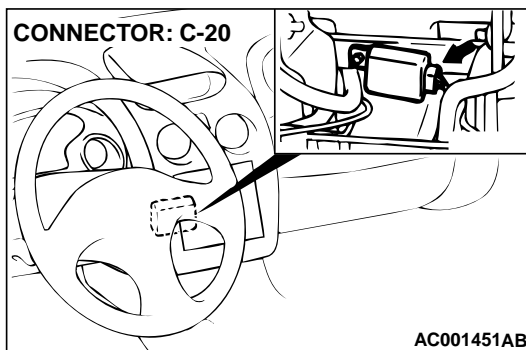

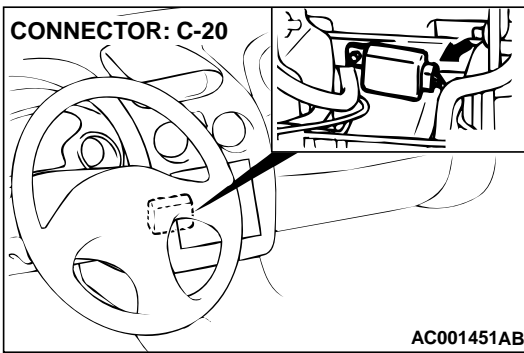

**STEP 7. Check the harness wire between auto-cruise control-ECU connector C-20 and ground.**

**Q: Is any harness wire between auto-cruise control-ECU connector C-20 and ground damaged?**

- YES :** Repair the harness wire and then check that the malfunction is eliminated.
- NO :** Check that the malfunction is eliminated.  
 If the malfunction is eliminated, replace the auto-cruise control-ECU. (Refer to [P.17-81.](#))  
 Then check that the malfunction is eliminated.

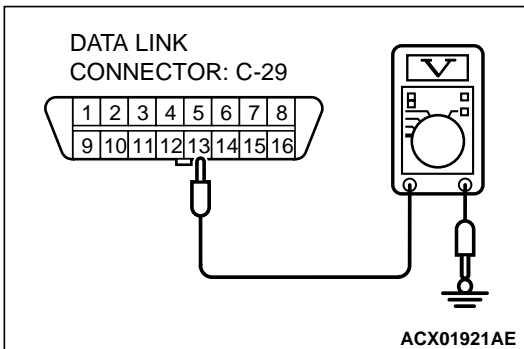

**STEP 8. Check the output circuit voltage at data link connector C-29.**

- (1) Turn the ignition switch to "ON" position.
- (2) Measure the voltage between terminal 13 and ground.
- (3) Turn the ignition switch to "LOCK" (OFF) position.

**Q: Is the voltage approximately 4 volts or more?**

- YES :** Check that the malfunction is eliminated.  
 If the malfunction is eliminated, replace the auto-cruise control-ECU. (Refer to [P.17-81.](#))  
 Then check that the malfunction is eliminated.
- NO :** Go to Step 9.

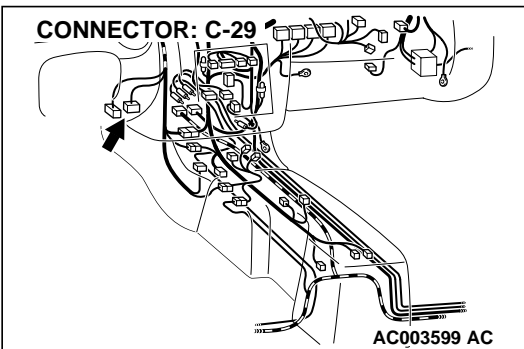

**STEP 9. Check data link connector C-29.**

**Q: Is the connector damaged?**

- YES :** Repair or replace connector.  
 Refer to GROUP 00E, Harness Connector Inspection [P.00E-2.](#)  
 Then check that the malfunction is eliminated.
- NO :** Go to Step 10.

**STEP10. Check the output circuit voltage at auto-cruise control-ECU connector C-20 by backprobing.**

- (1) Do not disconnect auto-cruise control switch connector C-20.
- (2) Turn the ignition switch to "ON" position.
- (3) Measure the voltage between terminal 11 and ground by backprobing.
- (4) Turn the ignition switch to "LOCK" (OFF) position.

**Q: Is the voltage approximately 4 volts or more?**

- YES :** Go to Step 11.  
**NO :** Go to Step 12.

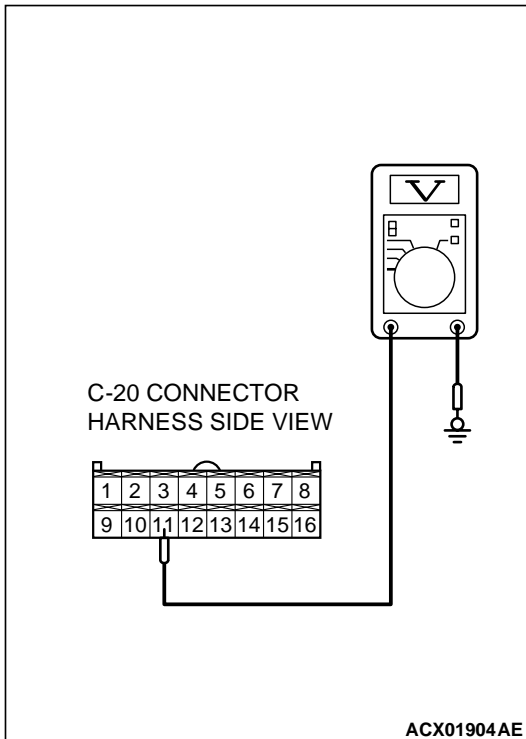

**STEP 11. Check the harness wire between auto-cruise control-ECU connector C-20 and data link connector C-29.**

**Q: Is any harness wire between auto-cruise control-ECU connector C-20 and data link connector C-29 damaged?**

- YES :** Repair the harness wire and then check that the malfunction is eliminated.
- NO :** Check that the malfunction is eliminated. If the malfunction is eliminated, replace the auto-cruise control-ECU. (Refer to P.17-81.) Then check that the malfunction is eliminated.

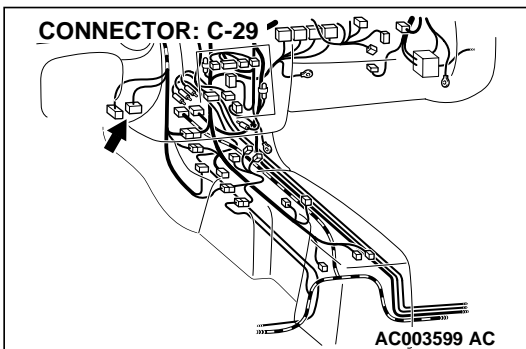
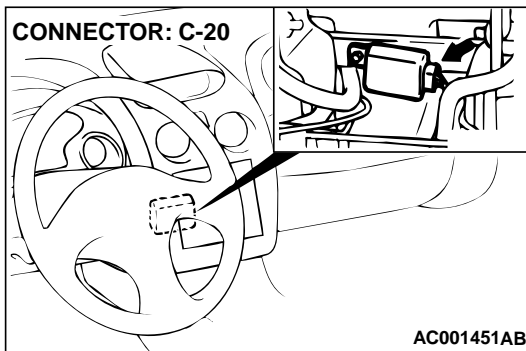

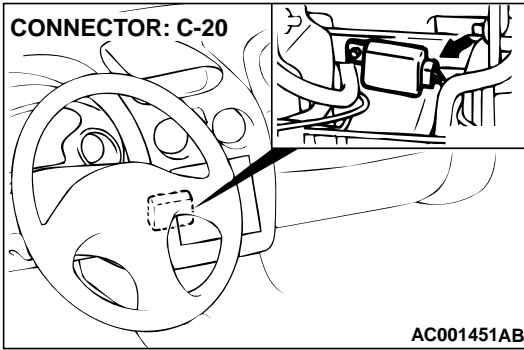

**STEP 12. Check auto-cruise control-ECU connector C-20.**

**Q: Is the connector damaged?**

**YES :** Repair or replace connector.

Refer to GROUP 00E, Harness Connector Inspection

[P.00E-2.](#)

Then check that the malfunction is eliminated.

**NO :** Check that the malfunction is eliminated.

If the malfunction is eliminated, replace the auto-cruise control-ECU. (Refer to [P.17-81.](#))

Then check that the malfunction is eliminated.

**INSPECTION PROCEDURE 2: When the Brake Pedal is Depressed, Auto-cruise Control is not Cancelled.**

**Stoplight Switch Circuit**

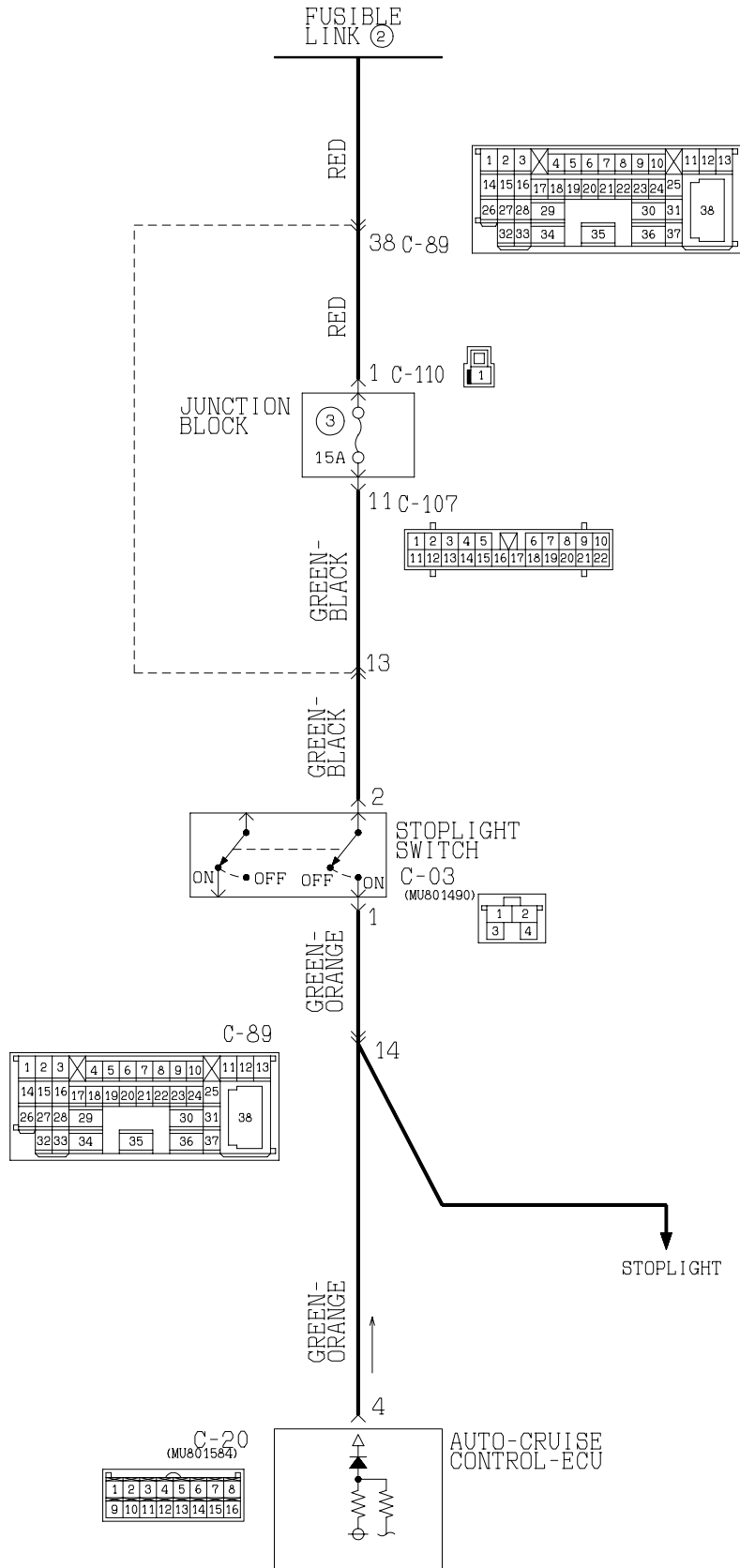

AC005114AB

TSB Revision

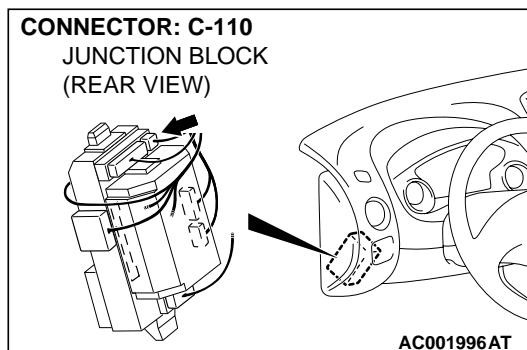
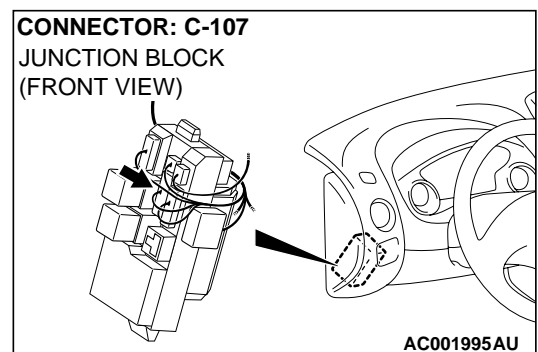
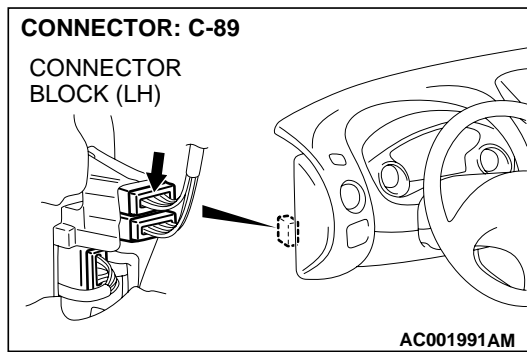
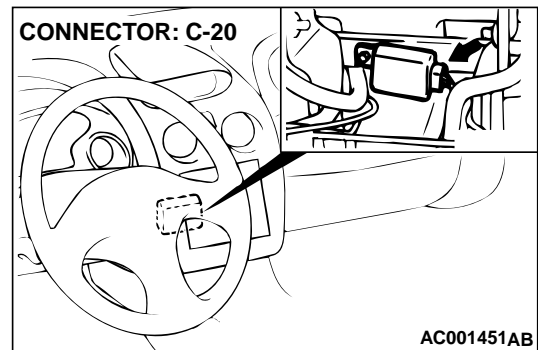
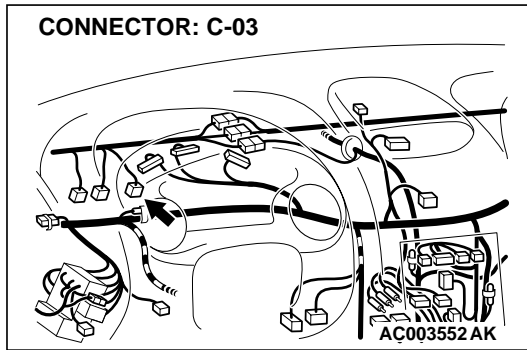

**CIRCUIT OPERATION**

This is the stoplight switch input signal circuit. The signal is sent to the stoplight switch from multi-purpose fuse 3, and is then sent to the auto-cruise control-ECU.

**TECHNICAL DESCRIPTION (COMMENT)**

The cause is probably a malfunction of the stoplight switch circuit.

**TROUBLESHOOTING HINTS**

- Malfunction of the stoplight switch.
- Damaged harness or connector.
- Malfunction of the auto-cruise control-ECU.

**DIAGNOSIS**

**Required Special Tool:**

- MB991223: Harness Set

**STEP 1. Check if the stoplight illuminates.**

**Q: Is the stoplight illuminated?**

**YES :** Go to Step 9.

**NO :** Go to Step 2.

**STEP 2. Check the 12-Volt supply circuit voltage at stoplight switch connector C-03.**

- (1) Disconnect stoplight switch connector C-03 and measure at the harness side.
- (2) Measure the voltage between terminal 2 and ground.

**Q: Is the voltage approximately battery positive voltage?**

**YES :** Go to Step 6.

**NO :** Go to Step 3.

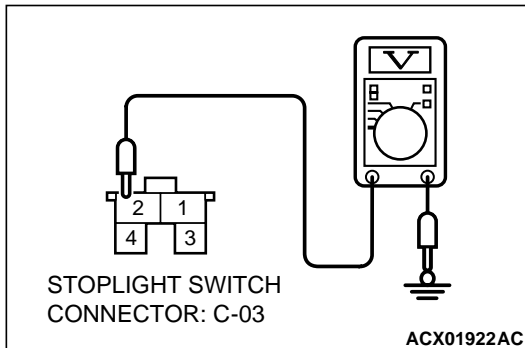
**STEP 3. Check stoplight switch connector C-03.**

**Q: Is the connector damaged?**

**YES :** Repair or replace connector.

Refer to GROUP 00E, Harness Connector Inspection

[P.00E-2.](#)

Then check that the malfunction is eliminated.

**NO :** Go to Step 4.

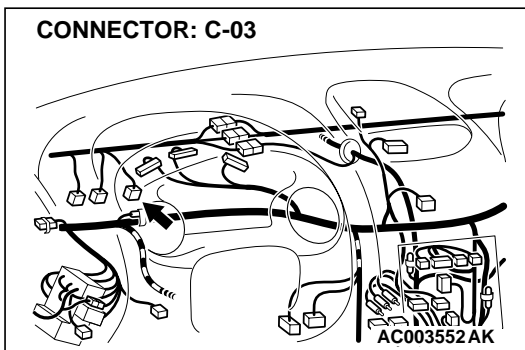



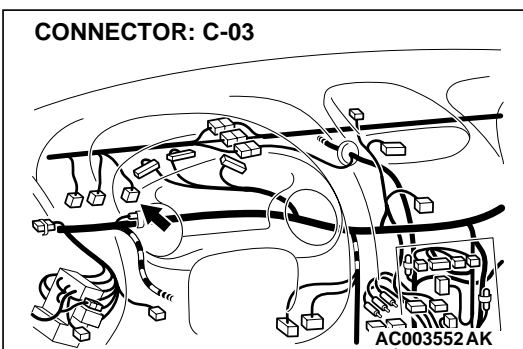
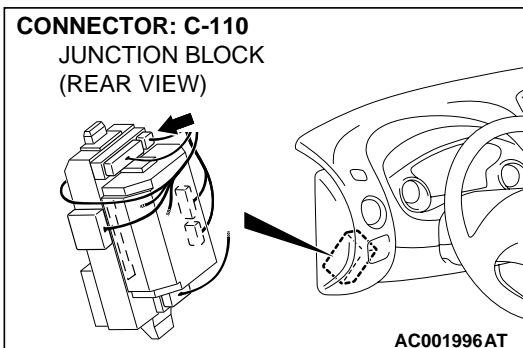
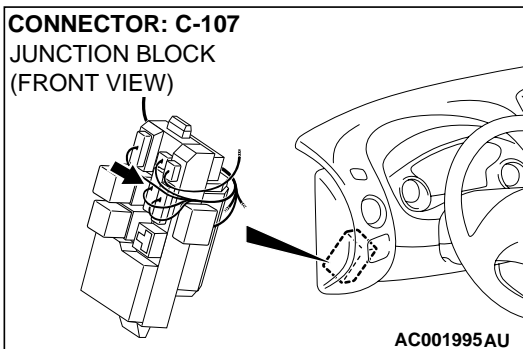
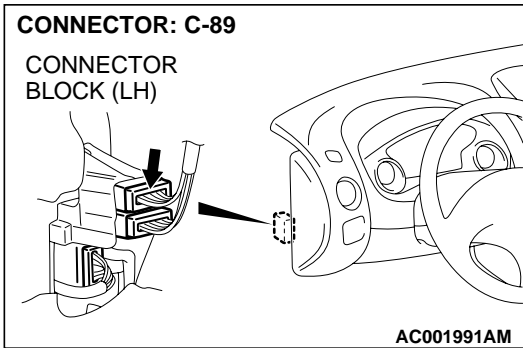

**STEP 4. Check intermediate connector C-89 and junction connector C-107 and C-110.**

**Q: Is any connectors damaged?**

**YES :** Repair or replace connector.

Refer to GROUP 00E, Harness Connector Inspection  
[P.00E-2.](#)

Then check that the malfunction is eliminated.

**NO :** Go to Step 5.

**STEP 5. Check the harness wire between fusible link No.2 and stoplight switch connector C-03.**

**Q: Is any harness wire between fusible link No.2 and stoplight switch connector C-03 damaged?**

**YES :** Repair the harness wire and then check that the malfunction is eliminated.

**NO :** Check that the malfunction is eliminated.  
If the malfunction is eliminated, replace the auto-cruise control-ECU. (Refer to [P.17-81.](#))  
Then check that the malfunction is eliminated.

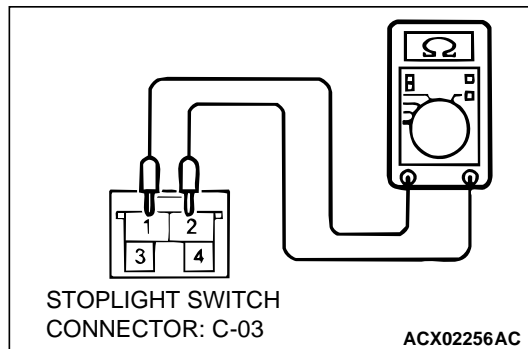
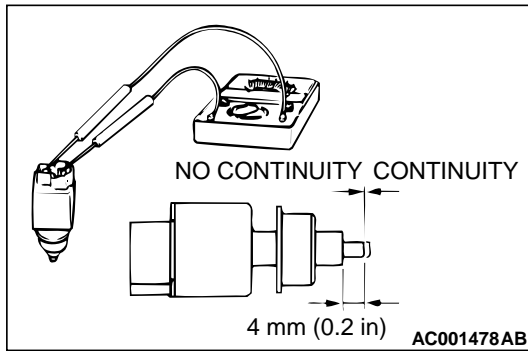
**STEP 6. Check the stoplight switch.**

- (1) Disconnect harness connector C-03 at the stoplight switch.
- (2) Connect an ohmmeter to the stoplight switch, and check continuity when the plunger of the stoplight switch is pushed in and when it is released.
- (3) The stoplight switch is in good condition if the circuit is open when the plunger is pushed in to a depth of within 4 mm (0.2 inch) from the outer case edge surface, and if the resistance value is less than 2 ohm when it is released.
- (4) The check for continuity should be made at terminals 1 and 2 of the stoplight switch.

**Q: Is the circuit open?**

**YES :** Replace the stoplight switch.

Refer to GROUP 35A, Brake Pedal [P.35A-31](#).

Then check that the malfunction is eliminated.

**NO :** Go to Step 7.

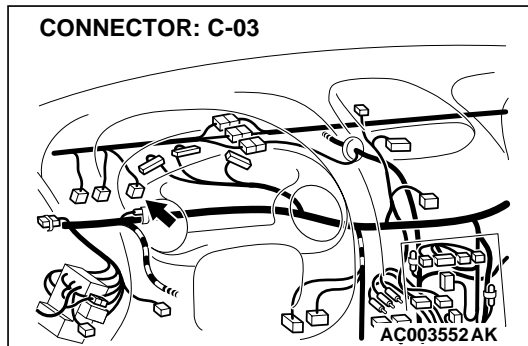
**STEP 7. Check stoplight switch connector C-03 and intermediate connector C-89.****Q: Is any connector damaged?**

**YES :** Repair or replace connector.

Refer to GROUP 00E, Harness Connector Inspection [P.00E-2](#).

Then check that the malfunction is eliminated.

**NO :** Go to Step 8.

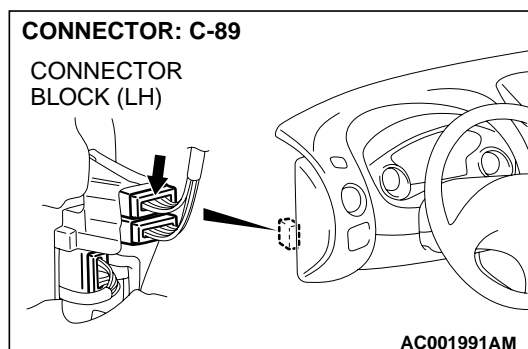

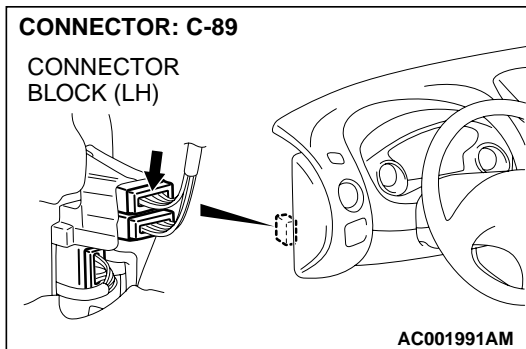
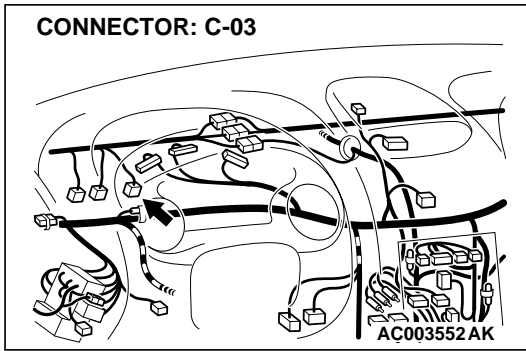

**STEP 8. Check the harness wire between stoplight switch connector C-03 and intermediate connector C-89.**

**Q: Is any harness wire between stoplight switch connector C-03 and intermediate connector C-89 damaged?**

**YES :** Repair the harness wire and then check that the malfunction is eliminated.

**NO :** Check that the malfunction is eliminated.  
 If the malfunction is eliminated, replace the auto-cruise control-ECU. (Refer to P.17-81.)  
 Then check that the malfunction is eliminated.

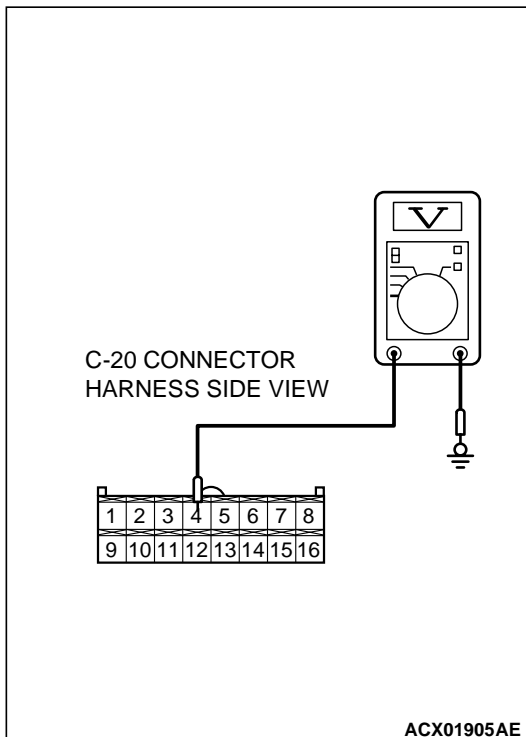

**STEP 9. Check the output circuit voltage at auto-cruise control-ECU connector C-20 by backprobing.**

(1) Do not disconnect auto-cruise control switch connector C-20.

(2) Turn the ignition switch to "ON" position.

(3) Measure the voltage between terminal 4 and ground by backprobing.

- Voltage should be battery positive volts. (When brake pedal is depressed.)
- Voltage should be 0.5 volts or less. (When brake pedal is not depressed.)

(4) Turn the ignition switch to "LOCK" (OFF) position.

**Q: Is the voltage within specifications?**

**YES :** Check that the malfunction is eliminated.

If the malfunction is eliminated, replace the auto-cruise control-ECU. (Refer to P.17-81.)

Then check that the malfunction is eliminated.

**NO :** Go to Step 10.

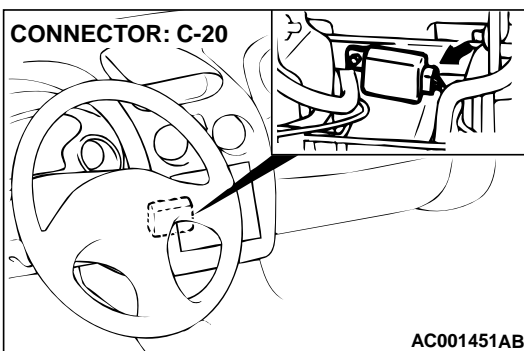
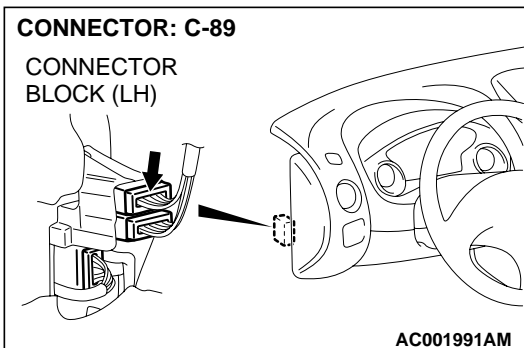
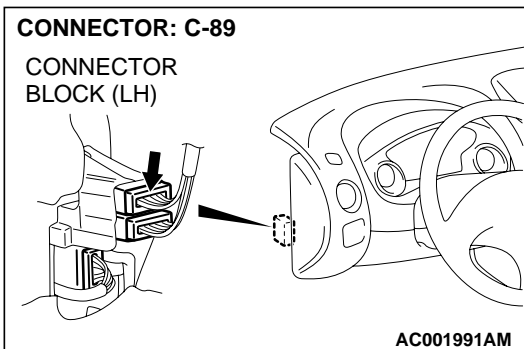
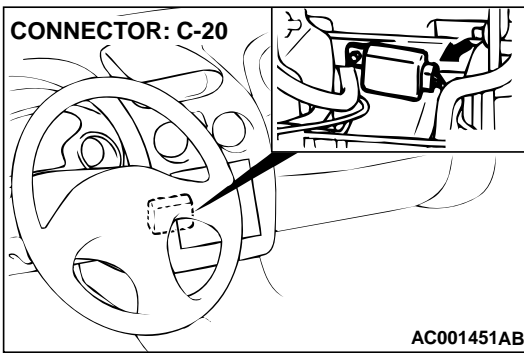

**STEP 10. Check auto-cruise control-ECU connector C-20 and intermediate connector C-89.**

**Q: Is the connector damaged?**

**YES :** Repair or replace connector.

Refer to GROUP 00E, Harness Connector Inspection [P.00E-2](#).

Then check that the malfunction is eliminated.

**NO :** Go to Step 11.

**STEP 11. Check the harness wire between intermediate connector C-89 and auto-cruise control-ECU connector C-20.**

**Q: Is any harness wire between intermediate connector C-89 and auto-cruise control-ECU connector C-20 damaged?**

**YES :** Repair the harness wire and then check that the malfunction is eliminated.

**NO :** Check that the malfunction is eliminated. If the malfunction is eliminated, replace the auto-cruise control-ECU. (Refer to [P.17-81](#).) Then check that the malfunction is eliminated.

**INSPECTION PROCEDURE 3: When the Clutch Pedal is Epressed, Auto-cruise Control is not Cancelled.**

**Clutch Pedal Position Switch Circuit**

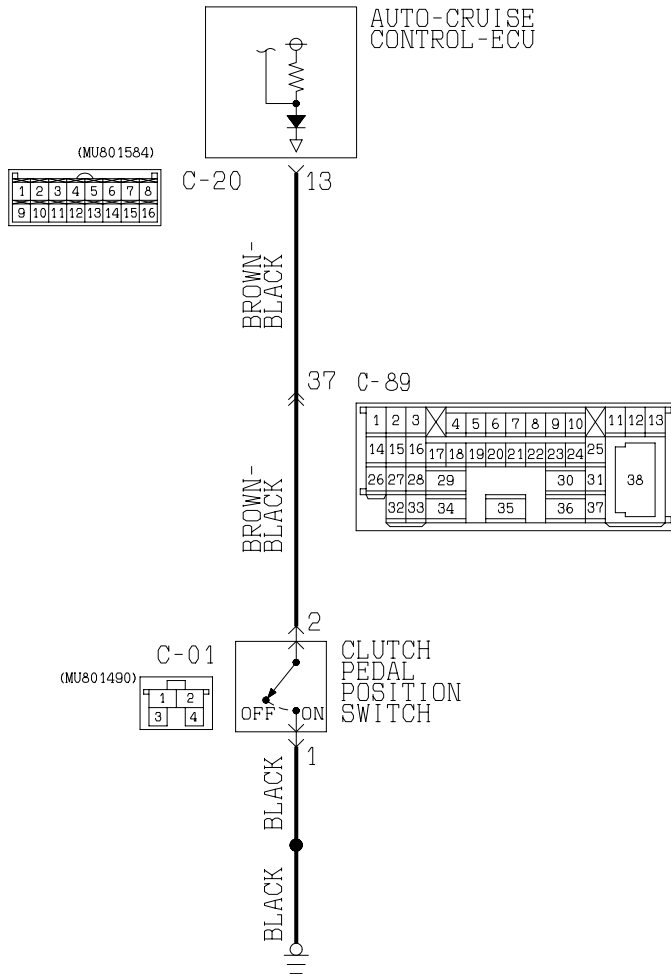

AC005115AB

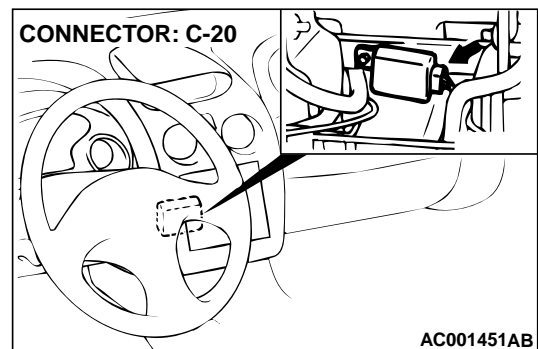
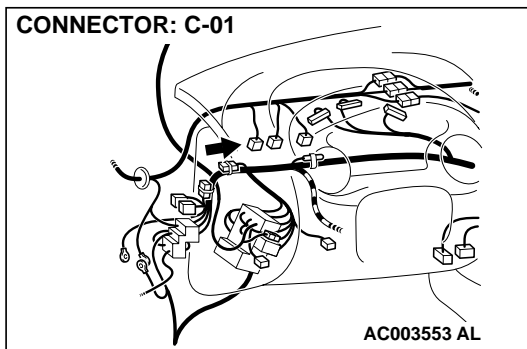

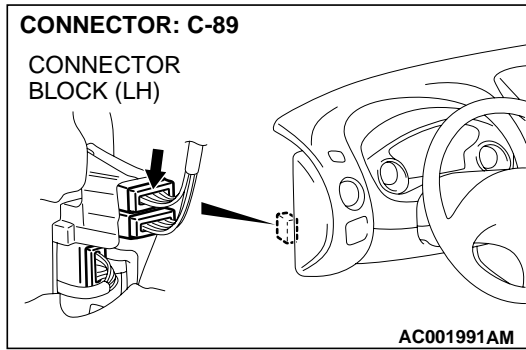

**CIRCUIT OPERATION**

This circuit indicates the operation status of the clutch pedal position switch. When the clutch pedal position switch is ON (clutch pedal is depressed), the voltage of auto-cruise control-ECU terminal number 13 will indicate 0 volt.

**TECHNICAL DESCRIPTION (COMMENT)**

The cause is probably a malfunction of the clutch pedal position switch circuit.

**TROUBLESHOOTING HINTS**

- Malfunction of the clutch pedal position switch.
- Damaged harness or connector.
- Malfunction of the auto-cruise control-ECU.

**DIAGNOSIS**

**STEP 1. Check the clutch pedal position switch.**

1. Disconnect clutch pedal position switch connector C-01.
2. Measure the continuity between the terminals.

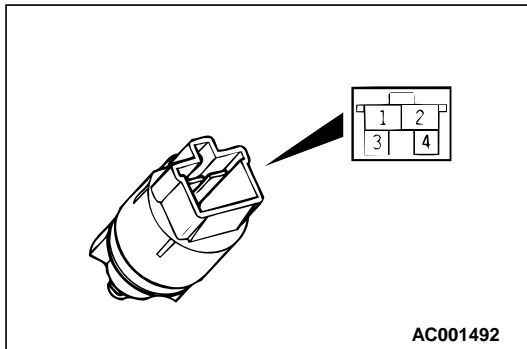

MEASUREMENT CONDITIONS	TERMINAL CONNECTOR OF TESTER	SPECIFIED CONDITION
When clutch pedal is depressed.	1 – 2	Continuity
When clutch pedal is not depressed.	1 – 2	No continuity

**Q: Is the continuity meet the table above?**

**YES :** Go to Step 2.

**NO :** Replace the clutch pedal position switch.  
 Refer to GROUP 23A, Transmission [P.21A-10](#).  
 Then check that the malfunction is eliminated.

**STEP 2. Check the output circuit voltage at auto-cruise control-ECU connector C-20 by backprobing.**

- (1) Do not disconnect auto-cruise control switch connector C-20.
- (2) Turn the ignition switch to "ON" position.
- (3) Measure the voltage between terminal 13 and ground by backprobing.
  - Voltage should be 0.5 volts or less.  
 (When clutch pedal is depressed.)
  - Voltage should be battery positive voltage.  
 (When clutch pedal is not depressed.)

**Q: Is the voltage within specifications?**

- YES :** Check that the malfunction is eliminated.  
 If the malfunction is eliminated, replace the auto-cruise control-ECU. (Refer to [P.17-81.](#))  
 Then check that the malfunction is eliminated.
- NO :** Go to Step 3.

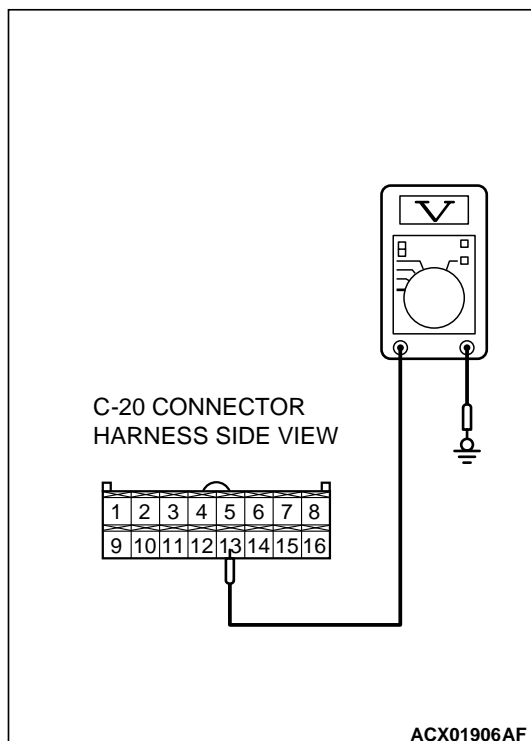

**STEP 3. Check clutch pedal position switch connector C-01 and auto-cruise control-ECU connector C-20 and intermediate connector C-89.**

**Q: Is any connector damaged?**

**YES :** Repair or replace connector.

Refer to GROUP 00E, Harness Connector Inspection

[P.00E-2.](#)

Then check that the malfunction is eliminated.

**NO :** Go to Step 4.

**CONNECTOR: C-01**

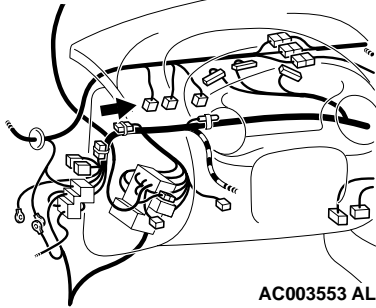

**CONNECTOR: C-20**

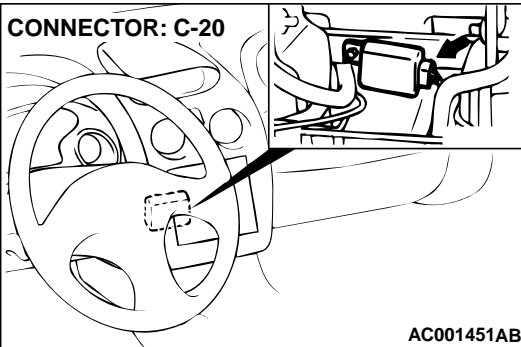

**CONNECTOR: C-89**

CONNECTOR  
BLOCK (LH)

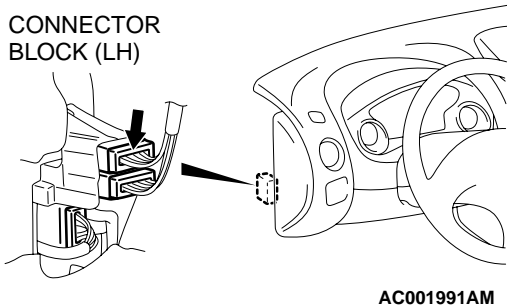



**STEP 4. Check the harness wire between clutch pedal position switch connector C-01 and auto-cruise control-ECU connector C-20.**

**Q: Is any harness wire between clutch pedal position switch connector C-01 and auto-cruise control-ECU connector C-20 damaged?**

**YES :** Repair the harness wire and then check that the malfunction is eliminated.

**NO :** Go to Step 5.

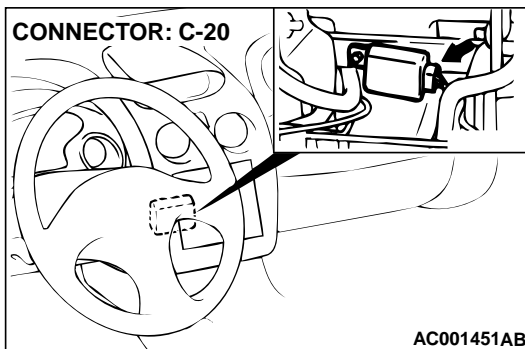
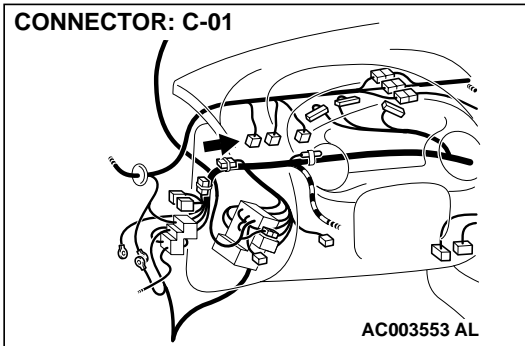

**STEP 5. Check the harness wire between clutch pedal position switch connector C-01 and ground wire.**

**Q: Is any harness wire between clutch pedal position switch connector C-01 and ground wire damaged?**

**YES :** Repair the harness wire and then check that the malfunction is eliminated.

**NO :** Check that the malfunction is eliminated.  
If the malfunction is eliminated, replace the auto-cruise control-ECU. (Refer to [P.17-81.](#))  
Then check that the malfunction is eliminated.

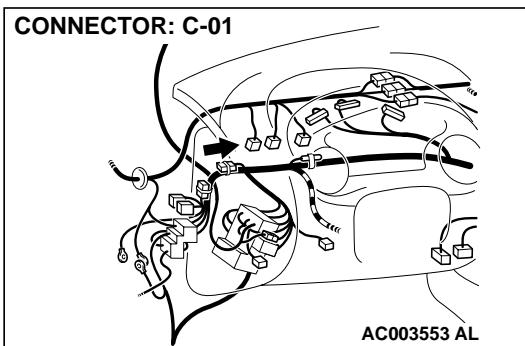

**INSPECTION PROCEDURE 4: When the Selector Lever is Moved to "N" Range, Auto-cruise Control is not Cancelled.**

**Park/neutral Position Switch Circuit**

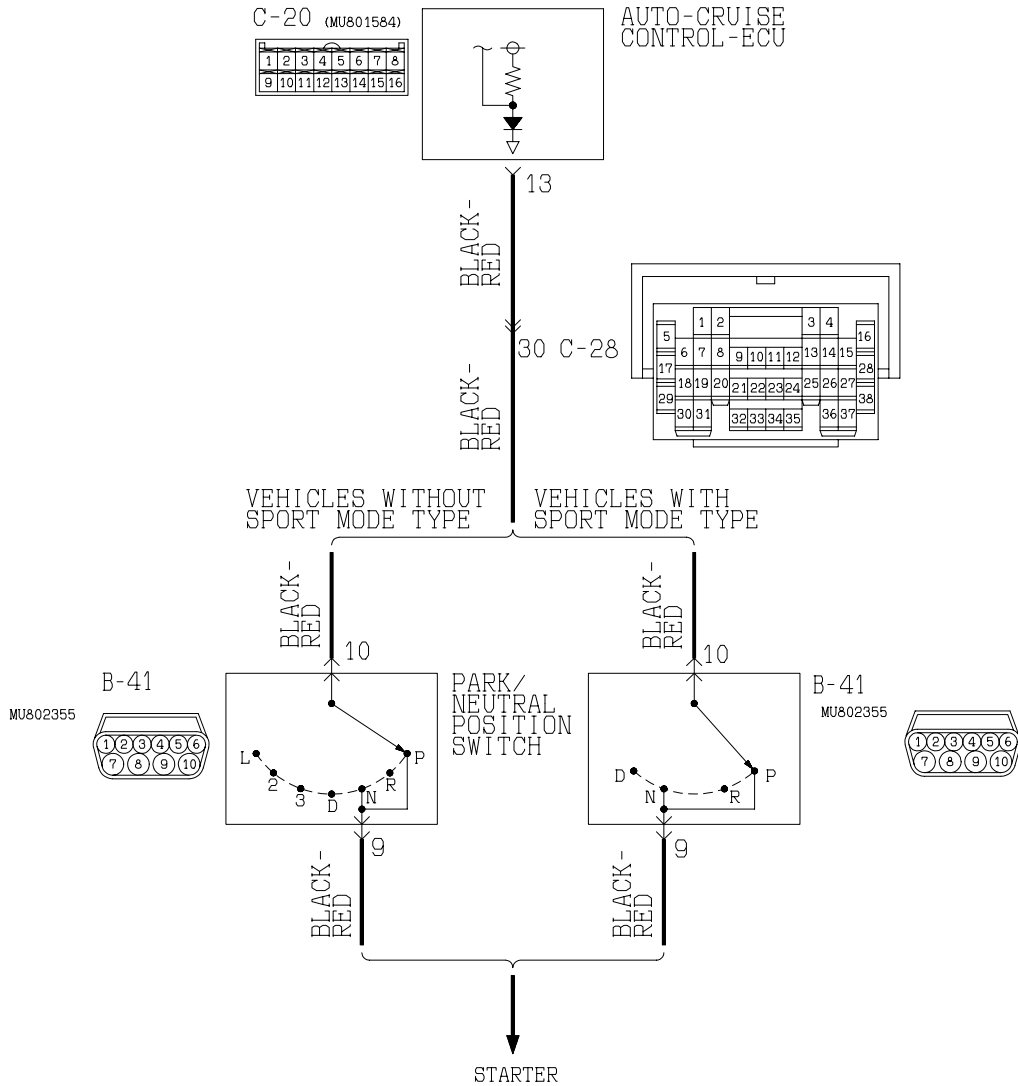

AC005116AB

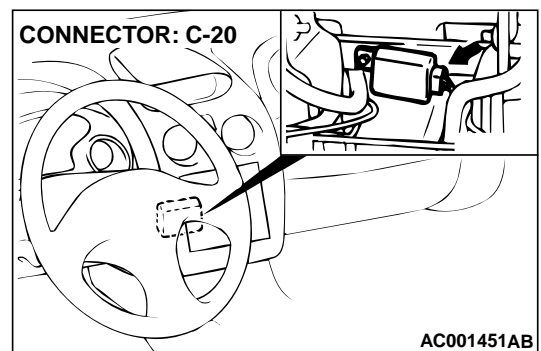
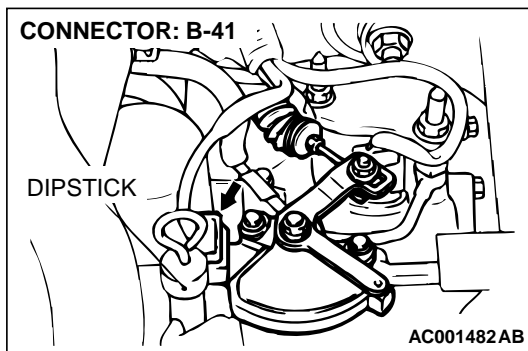

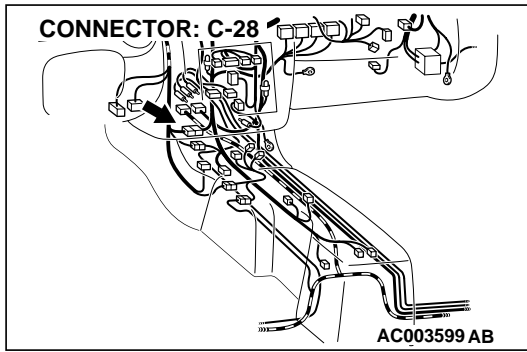

**CIRCUIT OPERATION**

This circuit transmits the "N" or "P" position signal of the park/neutral position switch to the auto-cruise control-ECU.

When the park/neutral position switch is at the "N" or "P" position, auto-cruise control-ECU terminal number 13 will receives 0 volt.

**TECHNICAL DESCRIPTION (COMMENT)**

The cause is probably an open-circuit in the output signal circuit in "N" range.

**TROUBLESHOOTING HINTS**

- Malfunction of the park/neutral position switch.
- Damaged harness or connector.
- Malfunction of the auto-cruise control-ECU.

**DIAGNOSIS**

**Required Special Tool:**

- MB991223: Harness Set

**STEP 1. Check the output circuit voltage at park/neutral position switch connector B-41 by backprobing.**

- (1) Do not disconnect park/neutral position switch connector B-41.
- (2) Turn the ignition switch to "ON" position.
- (3) Measure the voltage between terminal 10 and ground by backprobing.
  - Voltage should be battery positive voltage. (When select lever is in a position other than "N" range.)
  - Voltage should be 0.5 volts or less. (When select lever is in "N" range.)
- (4) Turn the ignition switch to "LOCK" (OFF) position.

**Q: Is the voltage within specifications?**

**YES** : Check that the malfunction is eliminated.  
 If the malfunction is eliminated, replace the auto-cruise control-ECU. (Refer to P.17-81.)  
 Then check that the malfunction is eliminated.

**NO** : Go to Step 2.

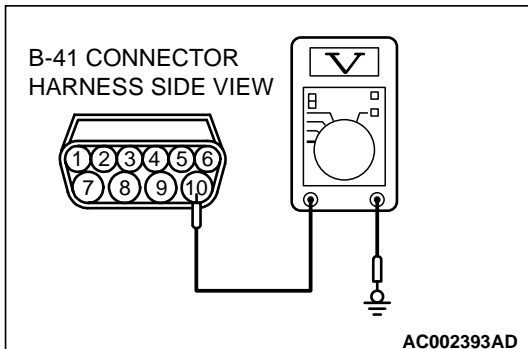

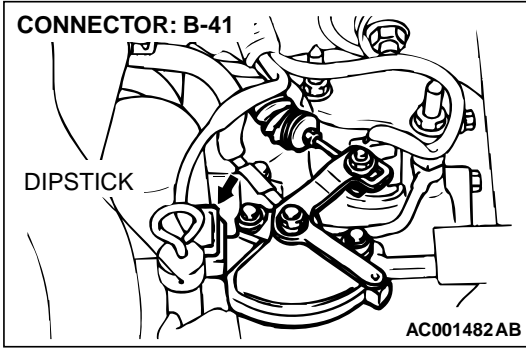

**STEP 2. park/neutral position switch connector B-41.**

**Q: Is the connector damaged?**

**YES :** Repair or replace connector.

Refer to GROUP 00E, Harness Connector Inspection

[P.00E-2.](#)

Then check that the malfunction is eliminated.

**NO :** Go to Step 3.

**STEP 3. Check the circuit at the park/neutral position switch.**

- (1) Disconnect the park/neutral position switch connector B-41.
- (2) Measure the continuity park/neutral position switch connector terminals.

ITEMS	TERMINAL CONNECTOR OF TESTER	SPECIFIED CONDITION
P	3 – 8, 9 – 10	Less than 2 ohm.
N	4 – 8, 9 – 10	

*NOTE: For vehicles with sport mode, four position (P.R.N.D) are available.*

**Q: Is the continuity meet the table above?**

**YES :** Go to Step 4.

**NO :** Replace the park/neutral position switch.

Refer to GROUP 23A, Transmission [P.23B-11.](#)

Then check that the malfunction is eliminated.

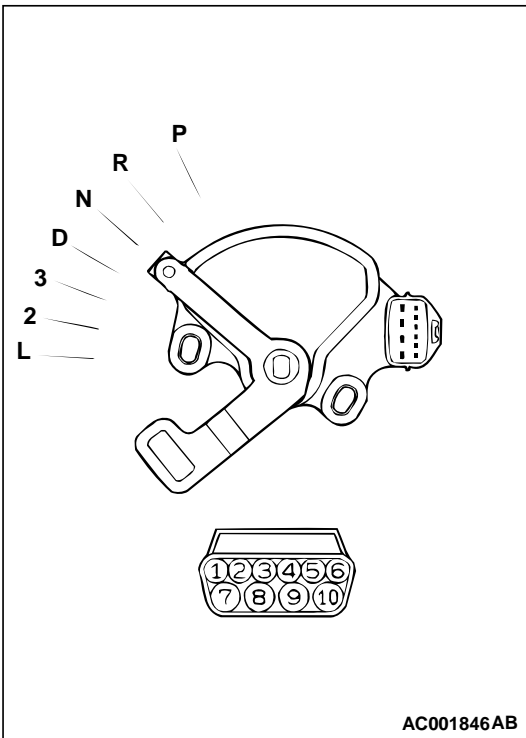

**STEP 4. Check the output circuit voltage at auto-cruise control-ECU connector C-20 by backprobing.**

- (1) Do not disconnect auto-cruise control switch connector C-20.
- (2) Turn the ignition switch to "ON" position.
- (3) Measure the voltage between terminal 13 and ground by backprobing.
  - Voltage should be battery positive voltage. (When select lever is in a position other than "N" range.)
  - Voltage should be 0.5 volts or less. (When select lever is in "N" range.)
- (4) Turn the ignition switch to "LOCK" (OFF) position.

**Q: Is the voltage within specifications?**

**YES :** Check that the malfunction is eliminated. If the malfunction is eliminated, replace the auto-cruise control-ECU. (Refer to [P.17-81.](#)) Then check that the malfunction is eliminated.

**NO :** Go to Step 5.

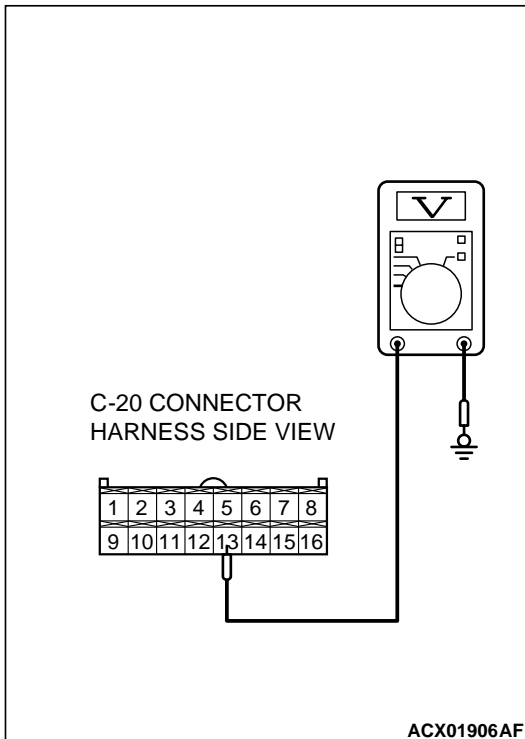

**STEP 5. Check auto-cruise control-ECU connector C-20.**

**Q: Is the connector damaged?**

**YES :** Repair or replace connector. Refer to GROUP 00E, Harness Connector Inspection [P.00E-2.](#) Then check that the malfunction is eliminated.

**NO :** Go to Step 6.

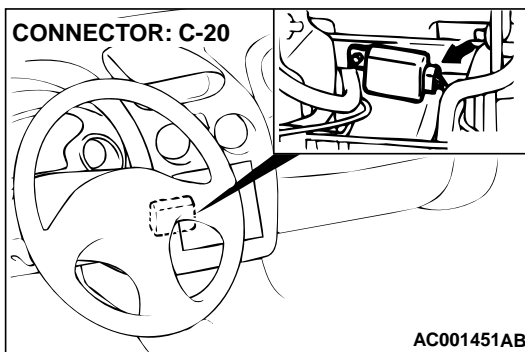

**STEP 6. Check intermediate connector C-28.**

**Q: Is the connector damaged?**

**YES :** Repair or replace connector. Refer to GROUP 00E, Harness Connector Inspection [P.00E-2.](#) Then check that the malfunction is eliminated.

**NO :** Go to Step 7.

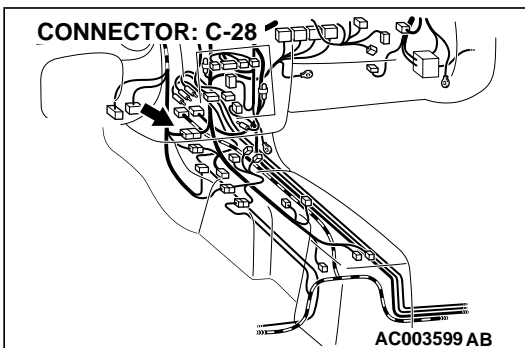

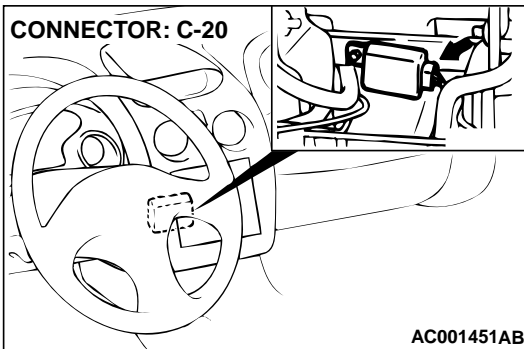
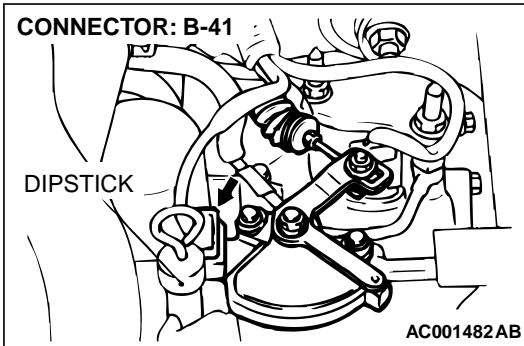

**STEP 7. Check the harness wire between park/neutral position switch connector B-41 and auto-cruise control-ECU connector C-20.**

**Q: Is any harness wire between park/neutral position switch connector B-41 and auto-cruise control-ECU connector C-20 damaged?**

**YES :** Repair the harness wire and then check that the malfunction is eliminated.

**NO :** Check that the malfunction is eliminated. If the malfunction is eliminated, replace the auto-cruise control-ECU. (Refer to [P.17-81.](#)) Then check that the malfunction is eliminated.

**INSPECTION PROCEDURE 5: When the Auto-cruise Control "CANCEL" Switch is Set to ON, Auto-cruise Control is not Cancelled.**

**TECHNICAL DESCRIPTION (COMMENT)**

The cause is probably an open-circuit in the output in the circuit inside the "CANCEL" switch.

**TROUBLESHOOTING HINTS**

- Malfunction of the auto-cruise control switch.

**DIAGNOSIS**

Replace the auto-cruise control switch. (Refer to [P.17-81.](#)) Then check the malfunction is eliminated.

**INSPECTION PROCEDURE 6: Auto-cruise control cannot be set.**

**TECHNICAL DESCRIPTION (COMMENT)**

The fail-safe function is probably cancelling auto-cruise control.

In this case, scan tool MB991502 can be used to check the trouble symptoms in each system by checking the diagnostic trouble codes.

The scan tool can also be used to check if the circuits of each input switch are normal or not by checking the input switch codes.

**TROUBLESHOOTING HINTS**

- Malfunction of the auto-cruise control switch.
- Malfunction of the auto-cruise control-ECU.
- Malfunction of the clutch pedal position switch <M/T>.
- Malfunction of the park/neutral position switch <A/T>.

**DIAGNOSIS**

**Required Special Tools:**

- MB991502: Scan Tool (MUT-II)
- MB991223: Harness Set

---

**STEP 1. Can the auto-cruise control-ECU communicate with scan tool MB991502?**

**⚠ CAUTION**

To prevent damage to scan tool MB991502, always turn the ignition switch to "LOCK" (OFF) position before connecting or disconnecting scan tool MB991502.

- (1) Using scan tool MB991502.
- (2) Connect scan tool MB991502 to the data link connector.
- (3) Turn the ignition switch to "ON" position.

**Q: Can the auto-cruise control-ECU communicate with the scan tool?**

**YES :** Go to Step 2.

**NO :** Inspect each trouble symptom.

(Refer to Inspection Procedure number 1 [P.17-39.](#))

---

**STEP 2. Is any diagnostic trouble code output?**

**Q: Is any diagnostic trouble code output?**

**YES :** Diagnostic trouble code number 11, 12, 14, 15, 16 or 17 is output, refer to the following.

(Code number 11 [P.17-11.](#))

(Code number 12 [P.17-16.](#))

(Code number 14 [P.17-19.](#))

(Code number 15 [P.17-28.](#))

(Code number 16 [P.17-33.](#))

(Code number 17 [P.17-34.](#))

Then check that the malfunction is eliminated.

**NO :** Go to Step 3.

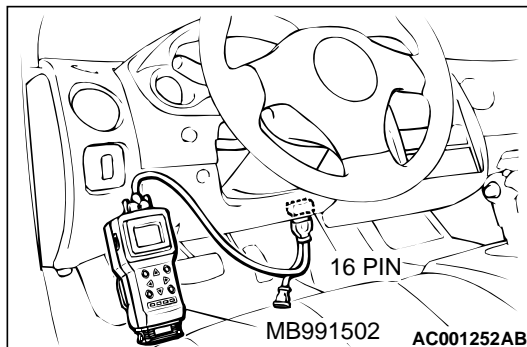

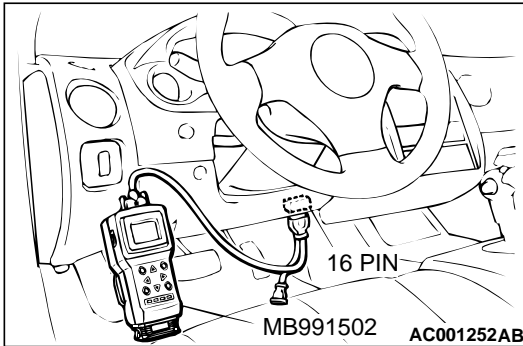
**STEP 3.Using scan tool MB991502, check data list.****⚠ CAUTION**

To prevent damage to scan tool MB991502, always turn the ignition switch to "LOCK" (OFF) position before connecting or disconnecting scan tool MB991502.

- (1) Using scan tool MB991502.
- (2) Connect scan tool MB991502 to the data link connector.
- (3) Check the following items in the data list.

Refer to [P.17-74](#), Data List Reference Table.

- Item 04: Auto-cruise control "CANCEL" switch.
- Item 05: Stoplight switch.
- Item 14: Clutch pedal position switch <M/T>.
- Item 14: Park/neutral position switch <A/T>.

- (4) Turn the ignition switch to "ON" position.

**Q: Is the check above meet the specifications?**

**YES** : Check that the malfunction is eliminated.

If the malfunction is eliminated, replace the auto-cruise control-ECU. (Refer to [P.17-81](#).)

Then that the malfunction is eliminated.

**NO** : Follow the diagnostic trouble code procedures and the symptom procedures below.

- Item 04: Refer to Diagnostic Trouble Code Procedures number 15 [P.17-28](#).
- Item 05: Refer to Symptom Procedures number 2 [P.17-46](#).
- Item 14: Refer to Symptom Procedures number 3 <M/T> [P.17-53](#).
- Item 14: Refer to Symptom Procedures number 4 <A/T> [P.17-58](#).



**INSPECTION PROCEDURE 7: Hunting (repeated acceleration and deceleration) occurs at the set vehicle speed.**

**TECHNICAL DESCRIPTION (COMMENT)**

The cause is probably the malfunction of the vehicle speed sensor or incorrect vacuum in the auto-cruise control vacuum pump or actuator.

**TROUBLESHOOTING HINTS**

- Malfunction of the vehicle speed sensor.
- Malfunction of the auto-cruise control vacuum pump.
- Malfunction of the actuator.
- Malfunction of the auto-cruise control-ECU.

**DIAGNOSIS**

**Required Special Tool:**

- MB991223: Harness Set

**STEP 1. Check the vehicle speed sensor.**

- (1) Remove the vehicle speed sensor and connect a 3 – 10 kΩ resistor as shown in the illustration.
- (2) Turn the shaft of the vehicle speed sensor and check that there is voltage between terminals 2 – 3. (one turn = four pulses)

**Q: Is the voltage within specifications?**

**YES :** Go to Step 2.

**NO :** Replace the vehicle speed sensor.  
 Refer to GROUP 54A, Combination Meter Assembly and Vehicle Speed Sensor P.54A-66.  
 Then check that the malfunction is eliminated.

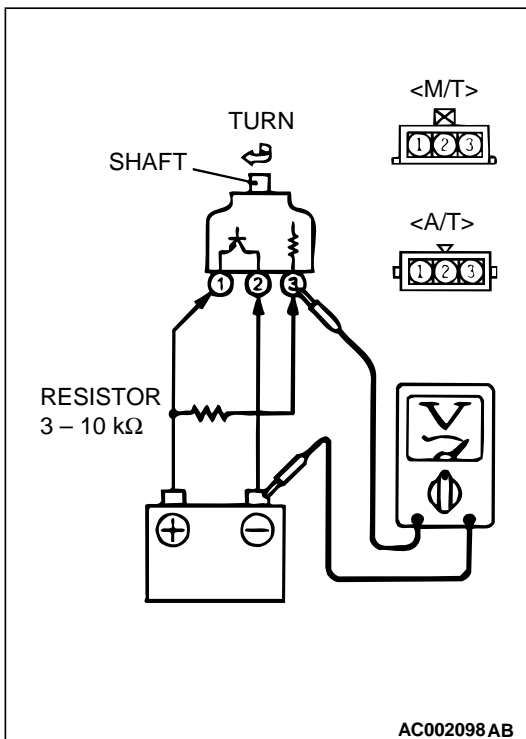

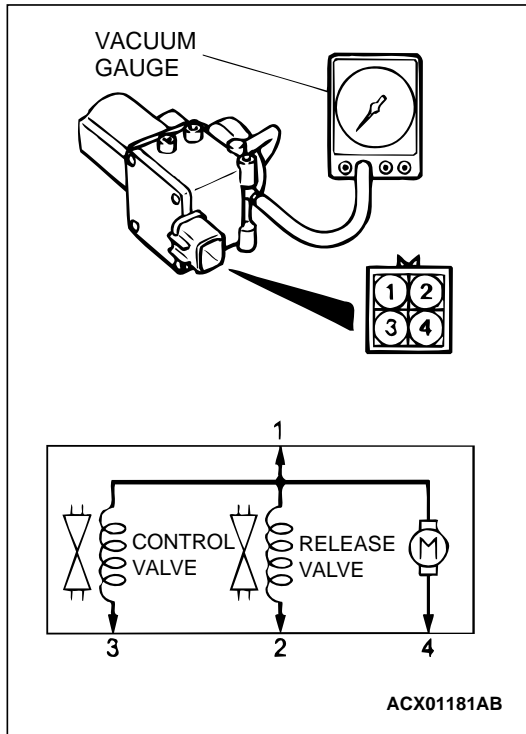
**STEP2. Check the auto-cruise vacuum pump.**

- (1) Disconnect the vacuum hose from the auto-cruise vacuum pump and connect a vacuum gauge to the vacuum pump.
- (2) Disconnect the vacuum pump connector.
- (3) Check the auto-cruise vacuum pump and valves according to the following procedure:
  - Connect the positive battery terminal to auto-cruise vacuum pump connector terminal 1, and the negative battery terminal to terminals 2, 3, and 4. Then the vacuum gauge should read 27 kPa (8.0 in Hg) or more.
  - The vacuum should be maintained when terminal 4 is disconnected from the negative battery terminal while terminals 1, 2, and 3 remain connected. Then the vacuum gauge should read 0 kPa (0 in Hg) when terminal 2 is disconnected from the negative battery terminal while terminals 1, and 3 remain connected.
  - The vacuum should be maintained when terminal 4 is disconnected from the negative battery terminal while terminals 1, 2, and 3 remain connected. Then the vacuum gauge should read 0 kPa (0 in Hg) when terminal 3 is disconnected from the negative battery terminal while terminals 1, and 2 remain connected.

**Q: Are all of the above values satisfied?****YES :** Go to Step 3.**NO :** Replace the auto-cruise vacuum pump. (Refer to [P.17-81.](#))

Then that the malfunction is eliminated.

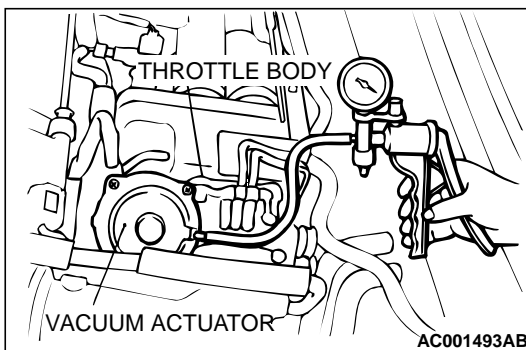
**STEP 3. Check the vacuum actuator.**

- (1) Disconnect the vacuum hose from the vacuum actuator, and then connect a hand vacuum pump to the vacuum actuator.
- (2) Apply a vacuum and check that the throttle lever moves and the vacuum is maintained.

**Q: Is the vacuum actuator damaged?****YES :** Replace the vacuum actuator.For 2.4L Engine, refer to GROUP 13A, Throttle Body Assembly [P.13A-489.](#)For 3.0L Engine, refer to GROUP 13B, Throttle Body Assembly [P.13B-565.](#)

Then check that the malfunction is eliminated.

**NO :** Check that the malfunction is eliminated.If the malfunction is eliminated, replace the auto-cruise control-ECU. (Refer to [P.17-81.](#))

Then check that the malfunction is eliminated.

**INSPECTION PROCEDURE 8: Auto-cruise Control Indicator Light inside Combination Meter does not Illuminate. (However, Auto-cruise Control is Normal.)**

**Auto-cruise Control Indicator Light Drive Circuit**

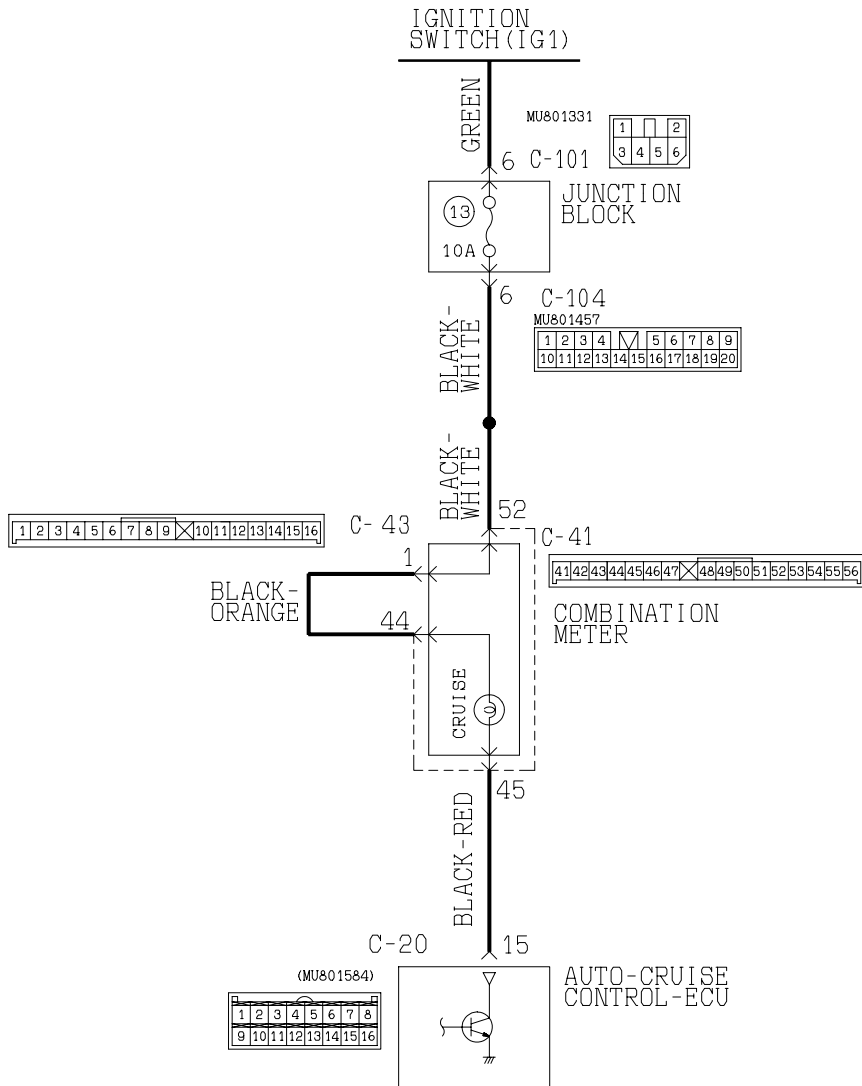

AC005117AB

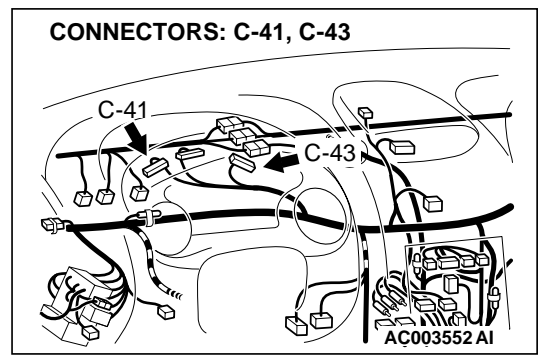
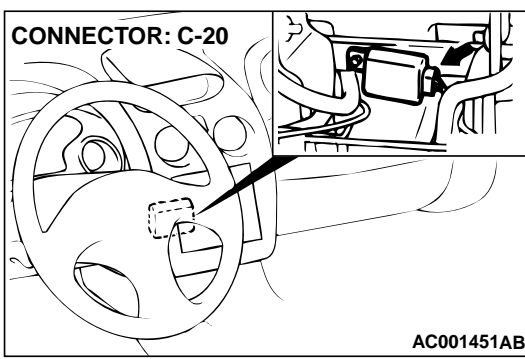

**TSB Revision**

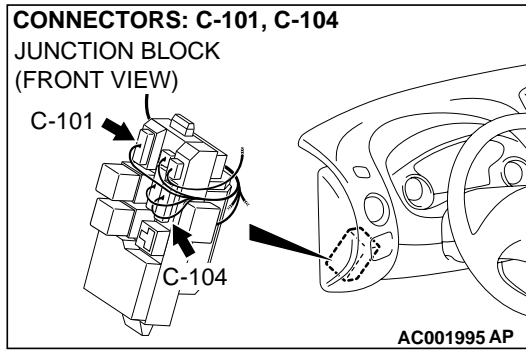

### CIRCUIT OPERATION

The power for the auto-cruise indicator in the combination meter is supplied from the ignition switch (IG1).

When the auto-cruise control system is operating, the transistor inside the auto-cruise control-ECU illuminates the auto-cruise indicator through ECU terminal number 15.

### TECHNICAL DESCRIPTION (COMMENT)

The cause is probably the malfunction of the indicator bulb or the malfunction of the connector or harness.

### TROUBLESHOOTING HINTS

- Malfunction of the indicator bulb.
- Damaged harness or connector.
- Malfunction of the auto-cruise control-ECU.

### DIAGNOSIS

#### Required Special Tool:

- MB991223: Harness Set

---

#### STEP 1. Check the auto-cruise control indicator bulb.

(1) Remove the combination meter.

Refer to GROUP54A, Combination Meter Assembly and Vehicle Speed Sensor [P.54A-66](#).

(2) Check the auto-cruise control indicator bulb.

#### Q: Is the bulb blown?

**YES** : Replace the bulb.

Then check that the malfunction is eliminated.

**NO** : Go to Step 2.

**STEP 2. Check the output circuit voltage at auto-cruise control-ECU connector C-20 by backprobing.**

- (1) Do not disconnect auto-cruise control switch connector C-20.
- (2) Turn the ignition switch to "ON" position.
- (3) Measure the voltage between terminal 15 and ground by backprobing.
- (4) Turn the ignition switch to "LOCK" (OFF) position.

**Q: Is the voltage approximately battery positive voltage?**

**YES :** Check that the malfunction is eliminated.

If the malfunction is eliminated, replace the auto-cruise control-ECU. (Refer to P.17-81.)

Then check that the malfunction is eliminated.

**NO :** Go to Step 3.

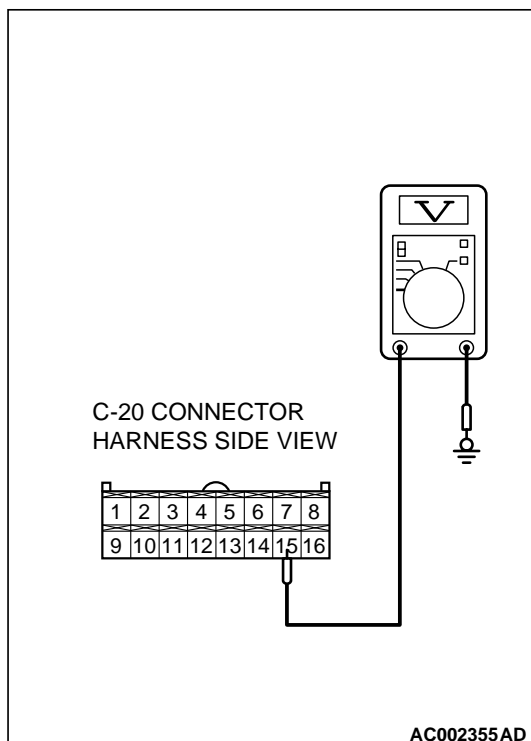

**STEP 3. Check the output circuit voltage at junction block connector C-104 by backprobing.**

- (1) Do not disconnect auto-cruise control switch connector C-104.
- (2) Turn the ignition switch to "ON" position.
- (3) Measure the voltage between terminal 6 and ground by backprobing.
- (4) Turn the ignition switch to "LOCK" (OFF) position.

**Q: Is the voltage approximately battery positive voltage?**

**YES :** Go to Step 5.

**NO :** Go to Step 4.

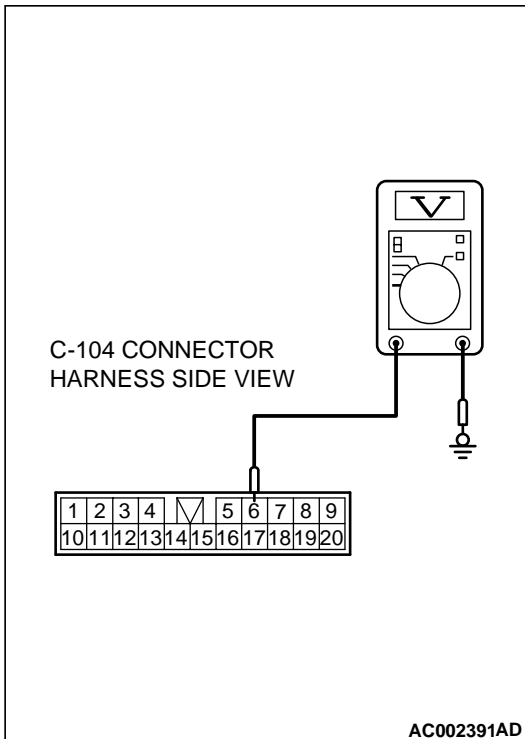

**STEP 4. Check junction block connector C-104.**

**Q: Is the connector damaged?**

**YES :** Repair or replace connector.

Refer to GROUP 00E, Harness Connector Inspection [P.00E-2](#).

Then check that the malfunction is eliminated.

**NO :** Replace the junction block.

Then check that the malfunction is eliminated.

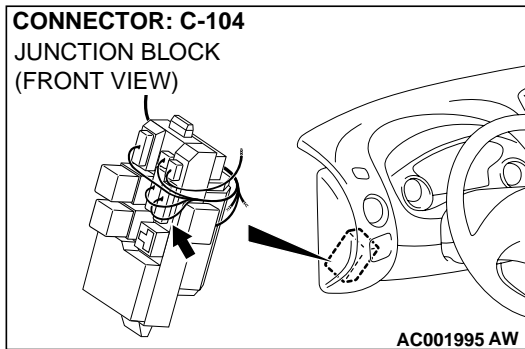

**STEP 5. Check combination meter connector C-41 and C-43.**

**Q: Is any connector damaged?**

**YES :** Repair or replace connector.

Refer to GROUP 00E, Harness Connector Inspection  
[P.00E-2.](#)

Then check that the malfunction is eliminated.

**NO :** Go to Step 6.

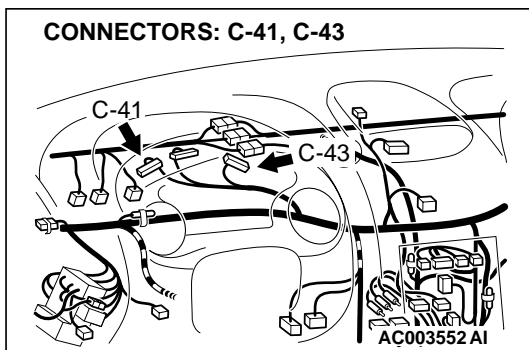

**STEP 6. Check the harness wire between combination meter connector C-41 and junction block connector C-104.**

**Q: Is any harness wire between combination meter connector C-41 and junction block connector C-104 damaged?**

**YES :** Repair the harness wire and then check that the malfunction is eliminated.

**NO :** Go to Step 7.

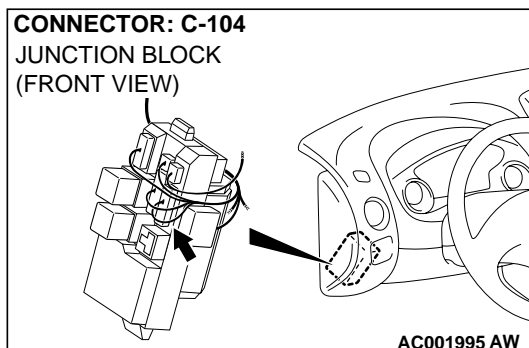
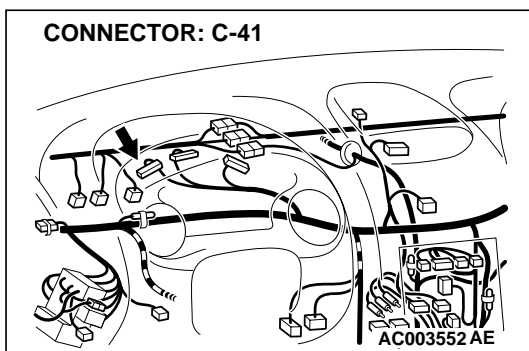

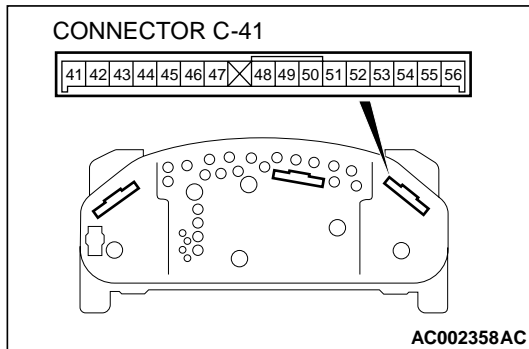

**STEP 7. Check the combination meter.**

- (1) Remove the combination meter and measure at the combination meter side. (Refer to GROUP 54A, Combination Meter Assembly and Vehicle Speed Sensor P.54A-66.)
- (2) Measure the continuity between terminal 44 and 45 at conductor C-41.

**Q: Is the continuity less than 2 ohm?**

**YES :** Go to Step 8.

**NO :** Replace the combination meter.  
 Refer to GROUP 54A, Combination Meter Assembly and Vehicle Speed Sensor P.54A-66.  
 Then check that the malfunction is eliminated.

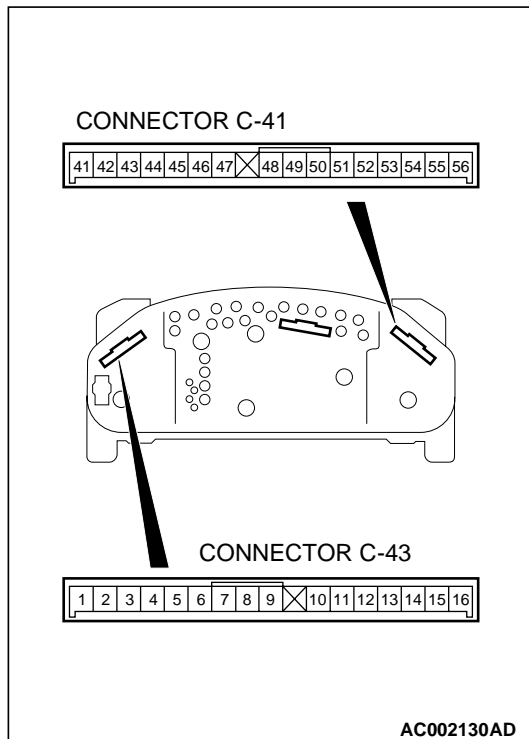

**STEP 8. Check the combination meter.**

- (1) Remove the combination meter and measure at the combination meter side. (Refer to GROUP 54A, Combination Meter Assembly and Vehicle Speed Sensor P.54A-66.)
- (2) Measure the continuity between terminal 52 at conductor C-41 and terminal 1 at conductor C-43.

**Q: Is the continuity less than 2 ohm?**

**YES :** Go to Step 9.

**NO :** Replace the combination meter.  
 Refer to GROUP 54A, Combination Meter Assembly and Vehicle Speed Sensor P.54A-66.  
 Then check that the malfunction is eliminated.



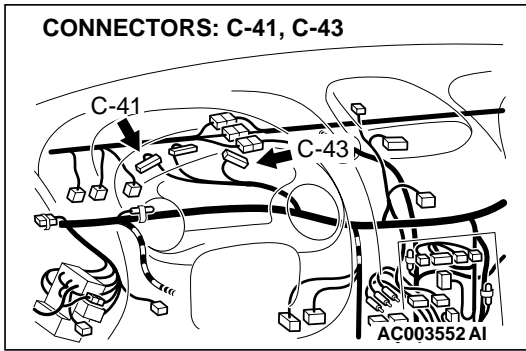

**STEP 9. Check the harness wire between combination meter connector C-41 and C-43.**

**Q: Is any harness wire between combination meter connector C-41 and C-43 damaged?**

**YES :** Repair the harness wire and then check that the malfunction is eliminated.

**NO :** Go to Step 10.

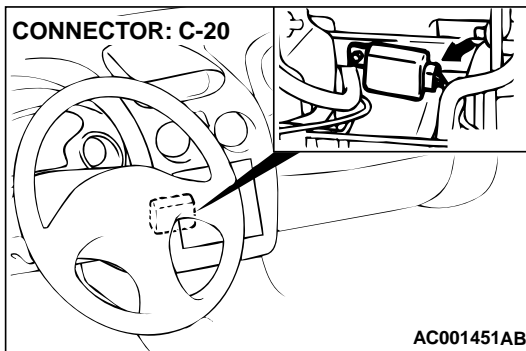

**STEP 10. Check auto-cruise control-ECU connector C-20.**

**Q: Is the connector damaged?**

**YES :** Repair or replace connector.

Refer to GROUP 00E, Harness Connector Inspection [P.00E-2](#).

Then check that the malfunction is eliminated.

**NO :** Go to Step 11.

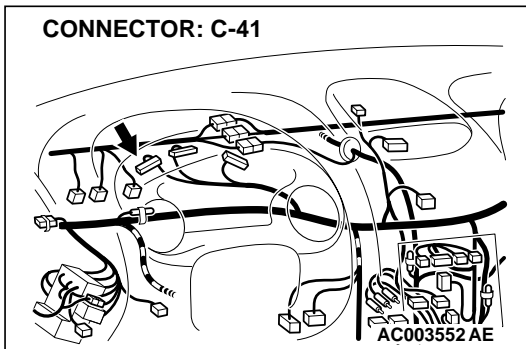

**STEP 11. Check the harness wire between combination meter connector C-41 and auto-cruise control-ECU connector C-20.**

**Q: Is any harness wire between combination meter connector C-41 and auto-cruise control-ECU connector C-20 damaged?**

**YES :** Repair the harness wire and then check that the malfunction is eliminated.

**NO :** Check that the malfunction is eliminated. If the malfunction is eliminated, replace the auto-cruise control-ECU. (Refer to [P.17-81](#).) Then check that the malfunction is eliminated.

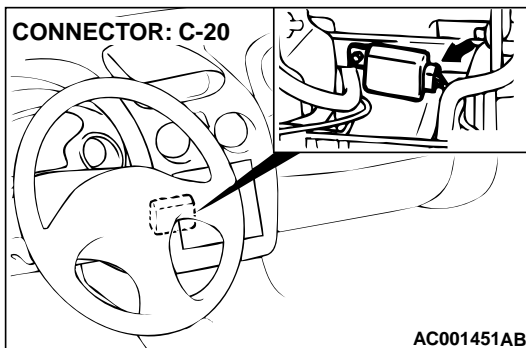

## DATA LIST REFERENCE TABLE

MUT-II SCAN TOOL DISPLAY	ITEM NO.	INSPECTION ITEM		INSPECTION REQUIREMENT		NORMAL CONDITION	
CANCEL SWITCH	04	Auto-cruise control switch	CANCEL	CANCEL switch: "ON"	ON		
				CANCEL switch: "OFF"	OFF		
IDLE SW SIG	08	Closed throttle position switch		Accelerator pedal: Depressed	OFF		
				Accelerator pedal: Released	ON		
MAIN SW	01	Auto-cruise control switch	MAIN	MAIN switch: "ON"	ON		
				MAIN switch: "OFF"	OFF		
OD OFF	15	A/T control signal		NO OD-OFF request	OFF		
				OD-OFF request	ON		
PNP SW/CLUTCH	14	Clutch switch <M/T>		Clutch pedal: Depressed <M/T>	ON		
				Clutch pedal: Released <M/T>	OFF		
		Park/neutral position switch <A/T>		Selector lever: "P" or "N" position <A/T>	ON		
				Selector lever: Other than "P" or "N" position <A/T>	OFF		
RESUME SWITCH	03	Auto-cruise control switch	RESUME	RESUME switch: "ON"	ON		
				RESUME switch: "OFF"	OFF		
SET SWITCH	02	Auto-cruise control switch	SET	SET switch: "ON"	ON		
				SET switch: "OFF"	OFF		
STOPLIGHT SW	05	Stoplight switch		Brake pedal: Depressed	ON		
				Brake pedal: Released	OFF		
TP SENSOR	13	Throttle position sensor		Ignition switch: "ON"	Accelerator pedal: Fully depressed	300 – 1,000 mV <2.4L> 537 – 735 mV <3.0L>	
					Accelerator pedal: Depressed	Increases in proportion to throttle opening angle.	
					Accelerator pedal: Released	4,000 – 5,500 mV	
VSS	10	Vehicle speed sensor		Road test the vehicle		The speedometer and MUT-II display the same value.	

**CHECK AUTO-CRUISE CONTROL-ECU TERMINALS**

M1172002700063

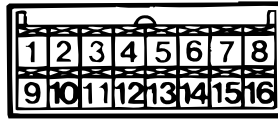

ACX02234

<b>TERMINAL NO.</b>	<b>INSPECTION ITEM</b>	<b>INSPECTION CONDITIONS</b>		<b>NORMAL CONDITION</b>
1	Throttle position sensor input	When accelerator pedal is fully depressed		4.0 – 5.5 V
		When accelerator pedal is released		0.3 – 1.0 V <2.4L> 0.5 – 0.7 V <3.0L>
2	Powertrain control module output (Idle switch)	When accelerator pedal is depressed		4.0 – 5.5 V
		When accelerator pedal is not depressed		2.5 V or less
3	A/T control output	No "OD-OFF" request		Battery positive voltage
		"OD-OFF" request		0 V
4	Stoplight switch input	When brake pedal is depressed	When stoplight switch is ON	Battery positive voltage
		When brake pedal is not depressed	When stoplight switch is OFF	0 V
5	Pump power supply	Ignition switch: "ON" position Stoplight switch: OFF		10 V or more
6	ECU power supply	Ignition switch: "ON" position		Battery positive voltage
7	Release valve	When decelerating with the "SET" switch while driving at constant speed		1 V or less
8	Control valve			10 V or more
7	Release valve	When cancelling constant speed driving with the "CANCEL" switch		10 V or more
8	Control valve			Battery positive voltage
9	Auto-cruise control switch input	When main switch is "ON"		Approximately 7.0 V
		When input switch has not been operated	When all switches are OFF	3.5 – 5.0 V
		When input switch is pushed down	When "SET" switch is ON	0.4 – 2.3 V
		When input switch is pushed up	When "RESUME" switch is ON	2.3 – 3.5 V
		When input switch is pulled forward	When "CANCEL" switch is ON	0.4 V or less
10	Vehicle speed sensor input	When vehicle is moved forwards and backwards, sensor turns ON and OFF repeatedly		0 V
		When sensor is OFF		4.5 V or more
		Ignition switch: "ON" position	Move the vehicle forward slowly	0 and 8– 12 V alternate

**TSB Revision**

TERMINAL NO.	INSPECTION ITEM	INSPECTION CONDITIONS		NORMAL CONDITION
11	Diagnosis control input	When ignition switch is "ON" position		4 V or more
12	ACC power supply	When ignition switch is in "ACC" position Main switch: "ON"		Battery positive voltage
13	Clutch pedal position switch input <M/T>	When pedal is not depressed	When clutch pedal position switch is OFF	Battery positive voltage
		When pedal is depressed	When clutch pedal position switch is ON	0 V
	Park/neutral position switch input <A/T>	When select lever is in a position other than N range	When park/neutral position switch is OFF	Battery positive voltage
		When select lever is in N range	When park/neutral position switch is ON	0 V
14	Ground	At any time		0 V
15	Indicator light input (inside combination meter)	When indicator light is illuminated		0 V
		When indicator light is switch off		Battery positive voltage
16	Auto-cruise vacuum pump motor input	When driving at constant speed using the "SET" switch	Motor stopped/running	Battery positive voltage/0 V
		When accelerating with the "RESUME" switch while driving at constant speed	Motor stopped/running	Battery positive voltage/0 V
		When decelerating with the "SET" switch while driving at constant speed	Motor stopped	Battery positive voltage
		When cancelling constant speed driving with the "CANCEL" switch	Motor stopped	Battery positive voltage

## ON-VEHICLE SERVICE

### AUTO-CRUISE CONTROL SWITCH CHECK

M1172001100079

1. Turn the ignition switch to "ON" position.
2. Check that the indicator light within the combination meter illuminates when the main switch is switched "ON".

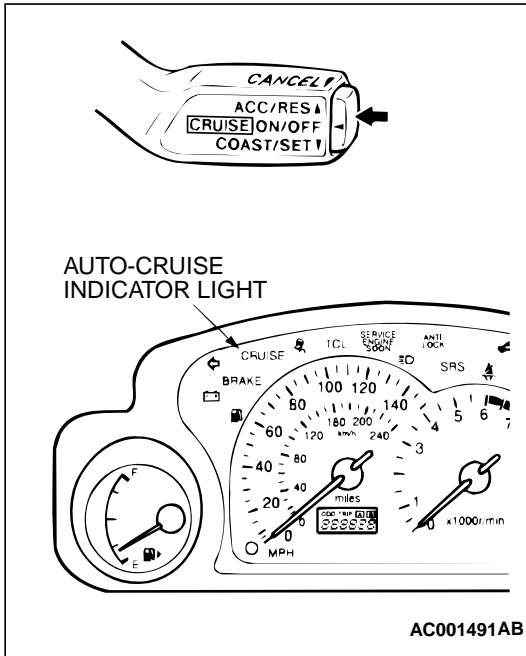

### AUTO-CRUISE CONTROL SETTING

1. Switch "ON" the main switch.
2. Drive at the desired speed, above approximately 40 km/h. (25 mph)
3. Push the auto-cruise control switch in the direction of arrow.
4. Check to be sure that when the switch is released the speed is the desired constant speed.

*NOTE: If the vehicles speed decreases to approximately 15 km/h (9 mph) below the set speed because of climbing a hill for example, the auto-cruise control will be cancelled.*

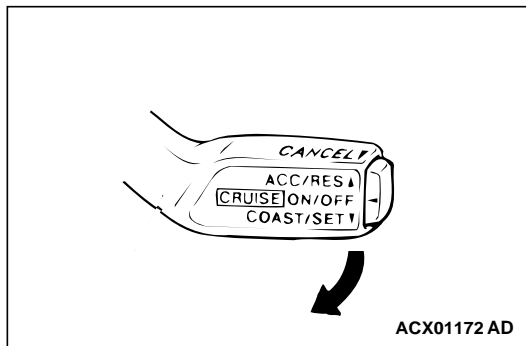

### SPEED-INCREASE SETTING

1. Set to the desired speed.
2. Push the auto-cruise control switch in the direction of arrow.
3. Check to be sure that acceleration continues while the switch is held, and that after it is released the constant speed at the time when it was released becomes the driving speed.

*NOTE: Acceleration can be continued even if the vehicle speed has passed the high-speed limit [approximately 200 km/h (124 mph)].*

*But the speed when the auto-cruise control switch is released will be recorded as the high-speed limit.*

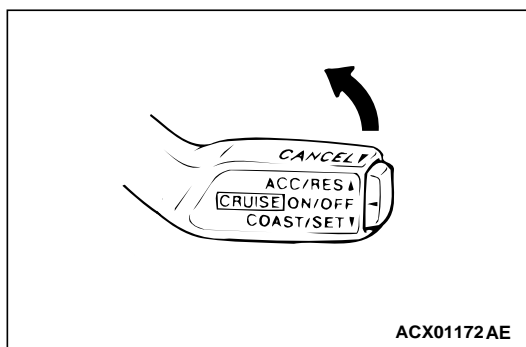

**SPEED-REDUCTION SETTING**

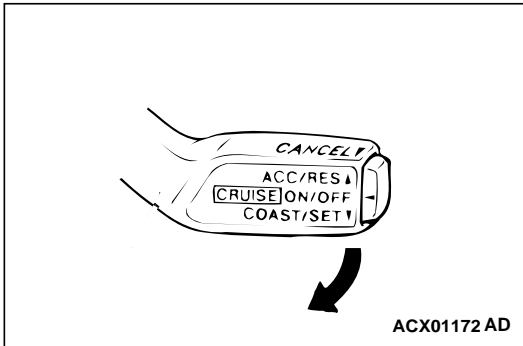

1. Set to the desired speed.
2. Push the auto-cruise control switch in the direction of arrow.
3. Check to be sure that deceleration continues while the switch is pressed, and that after it is released the constant speed at the time when it was released becomes the driving speed.

*NOTE: When the vehicle speed reaches the low limit [approximately 40 km/h (25 mph)] during deceleration, the auto-cruise control will be cancelled.*

**RETURN TO THE SET SPEED BEFORE CANCELLATION AND AUTO-CRUISE CONTROL CANCELLATION**

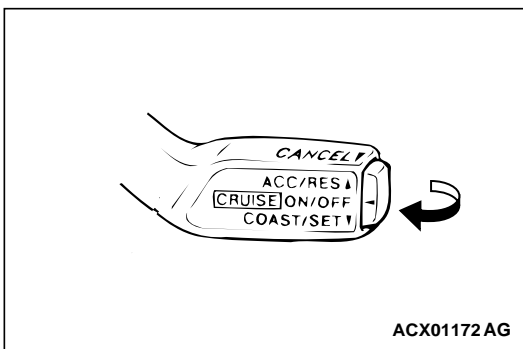

1. Set the auto-cruise speed control.
2. When any of the following operations are performed while at constant speed during auto-cruise control, check if normal driving is resumed and deceleration occurs.
  - (1) The auto-cruise control switch is pushed in the direction of arrow.
  - (2) The brake pedal is depressed.
  - (3) The clutch pedal is depressed. (M/T)
  - (4) The selector lever is moved to the "N" range. (A/T)
3. At a vehicle speed of 40 km/h (25 mph) or higher, check if when the "RESUME" switch is switched "ON," the vehicle speed returns to the speed before auto-cruise control driving was cancelled, and constant speed driving occurs.
4. When the main switch is turned to "OFF" while driving at constant speed, check if normal driving is resumed and deceleration occurs.

**AUTO-CRUISE CONTROL SYSTEM COMPONENT CHECK**

M1172001700071

**STOPLIGHT SWITCH**

1. Disconnect the connector.
2. Check for continuity between the terminals of the switch.

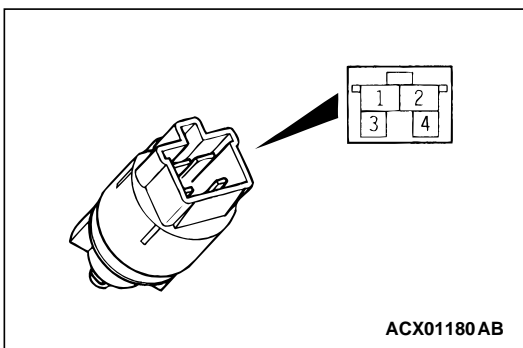

MEASUREMENT CONDITIONS	TERMINAL CONNECTOR OF TESTER	SPECIFIED CONDITION
When brake pedal is depressed. (for stoplight circuit)	1 – 2	Continuity
	3 – 4	No continuity
When brake pedal is not depressed. (for auto-cruise control circuit)	1 – 2	No continuity
	3 – 4	Continuity

### CLUTCH PEDAL POSITION SWITCH

1. Disconnect the connector.
2. Check for continuity between the terminals of the switch.

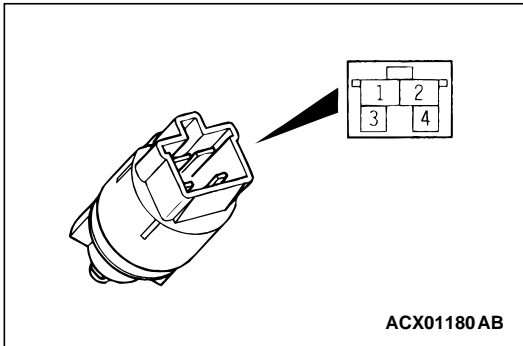

MEASUREMENT CONDITIONS	TERMINAL CONNECTOR OF TESTER	SPECIFIED CONDITION
When clutch pedal is depressed.	1 – 2	Continuity
When clutch pedal is not depressed.	1 – 2	No continuity

### PARK/NEUTRAL POSITION SWITCH ("N" POSITIN)

Refer to GROUP 23A, On-vehicle Service – Essential Service [P.23A-340](#).

### THROTTLE POSITION SENSOR

For 2.4L engine, refer to GROUP 13A, On-vehicle Service – Throttle Position Sensor Check [P.13A-480](#).

For 3.0L engine, refer to GROUP 13B, On-vehicle Service – Throttle Position Sensor Check [P.13B-557](#).

### AUTO-CRUISE VACUUM PUMP

1. Disconnect the vacuum hose from the auto-cruise vacuum pump and connect a vacuum gauge to the vacuum pump.
2. Disconnect the vacuum pump connector.
3. Check the auto-cruise vacuum pump and valves according to the following procedure:

- (1) Connect the positive battery terminal to auto-cruise vacuum pump connector terminal 1, and the negative battery terminal to terminals 2, 3, and 4. Then the vacuum gauge should read 27 kPa (8.0 in Hg) or more.
- (2) The vacuum should be maintained when terminal 4 is disconnected from the negative battery terminal while terminals 1, 2, and 3 remain connected. Then the vacuum gauge should read 0 kPa (0 in Hg) when terminal 2 is disconnected from the negative battery terminal while terminals 1, and 3 remain connected.
- (3) The vacuum should be maintained when terminal 4 is disconnected from the negative battery terminal while terminals 1, 2, and 3 remain connected. Then the vacuum gauge should read 0 kPa (0 in Hg) when terminal 3 is disconnected from the negative battery terminal while terminals 1, and 2 remain connected.

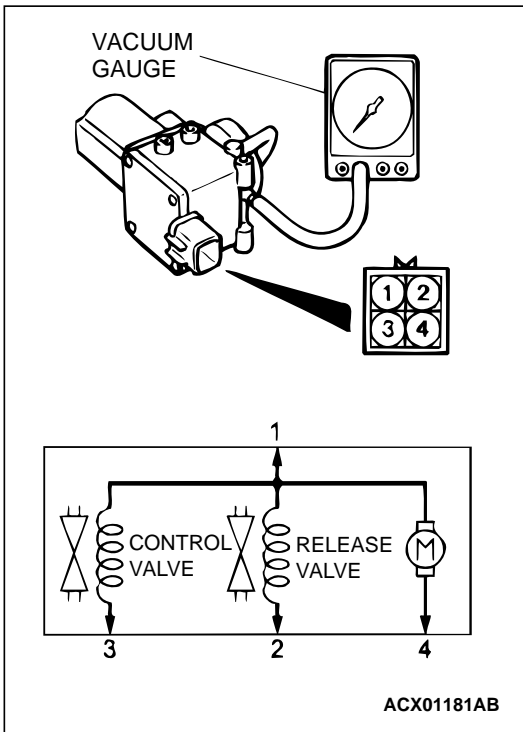

**VACUUM ACTUATOR**

1. Disconnect the vacuum hose from the vacuum actuator, and connect a hand vacuum pump to the actuator.
2. Check that the throttle lever operates when applying vacuum, and the vacuum is maintained.

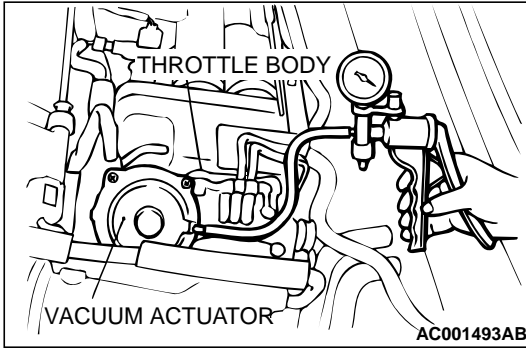

**AUTO-CRUISE CONTROL CHECK**

Measure the resistance between the terminals when each of the "SET," "RESUME," "CANCEL" and "MAIN" switches is pressed. If the values measured at the time correspond to those in the table below, the resistance values are correct.

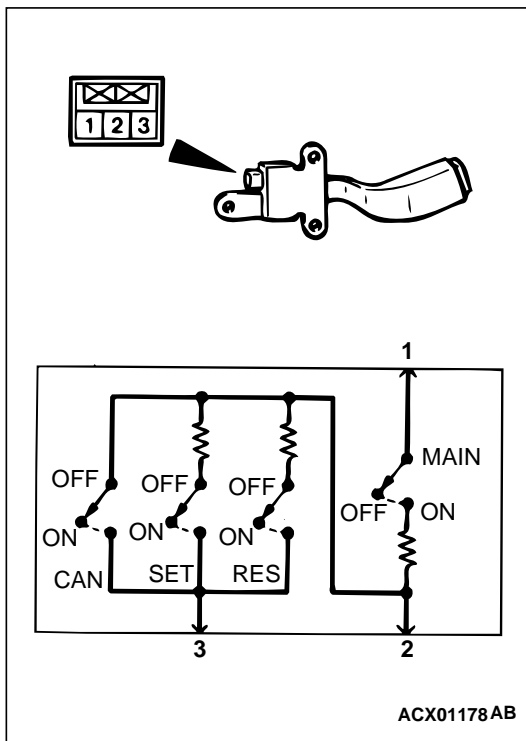

SWITCH POSITION	RESISTANCE BETWEEN TERMINALS	
"MAIN" switch OFF	Terminals 1 and 2	Less than 2 Ω
"MAIN" switch ON	Terminals 1 and 2	Approximately 3.9 kΩ
"CANCEL" switch ON	Terminals 2 and 3	Approximately 0 Ω
"RESUME" switch ON	Terminals 2 and 3	Approximately 910 Ω
"SET" switch ON	Terminals 2 and 3	Approximately 220 Ω

**VEHICLE SPEED SENSOR CHECK**

Refer to GROUP 54A, Combination Meters Assembly and Vehicle Speed Sensor [P.54A-67](#).



**AUTO-CRUISE CONTROL**  
**REMOVAL AND INSTALLATION**  
**<ACTUATOR>**

M1172001400069

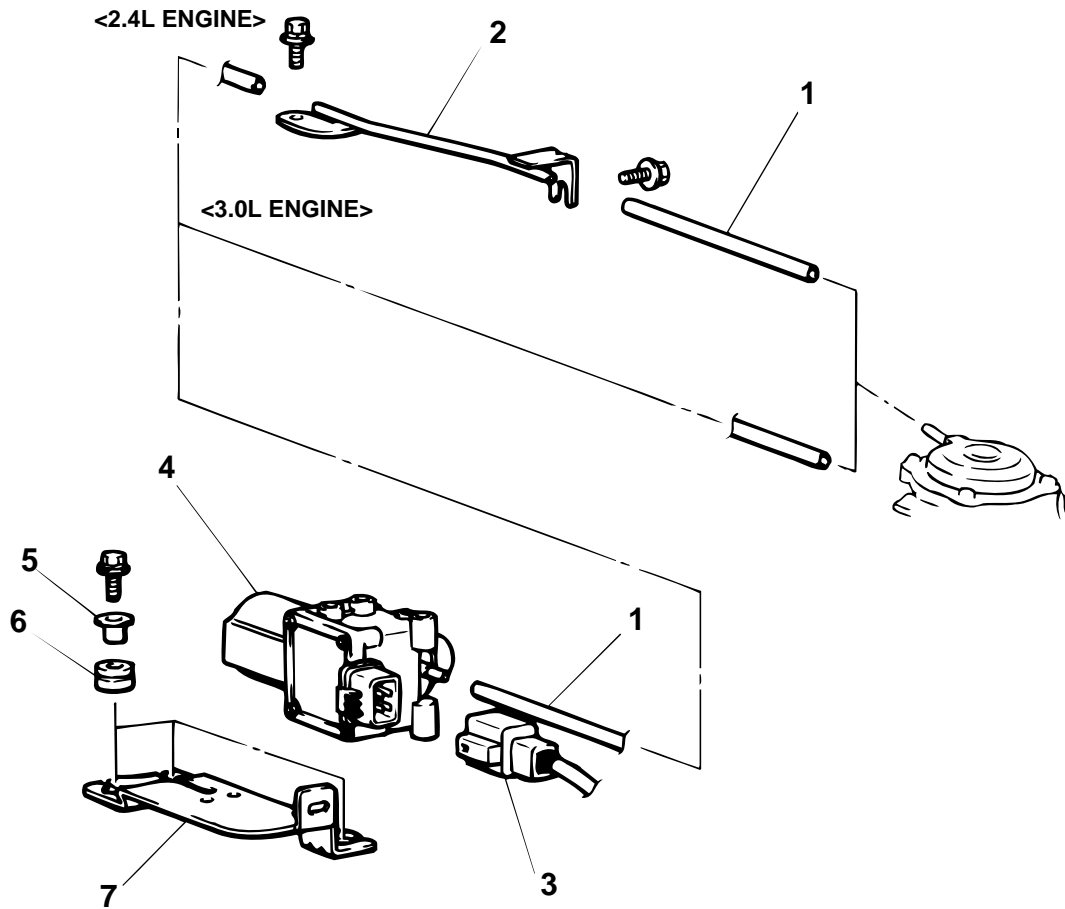

AC001494AB

**REMOVAL STEPS**

1. VACUUM HOSE
2. VACUUM PIPE
3. WIRING CONNECTOR
4. VACUUM PUMP ASSEMBLY

**REMOVAL STEPS (Continued)**

5. SPACER
6. RUBBER MOUNT
7. PUMP BRACKET

## &lt;SWITCHES, CONTROL UNIT AND SENSORS&gt;

**⚠ WARNING**

Before removal of the air bag module, refer to **GROUP 52B, SRS Service Precautions and GROUP 52B, Air Bag Module and Clock Spring.**

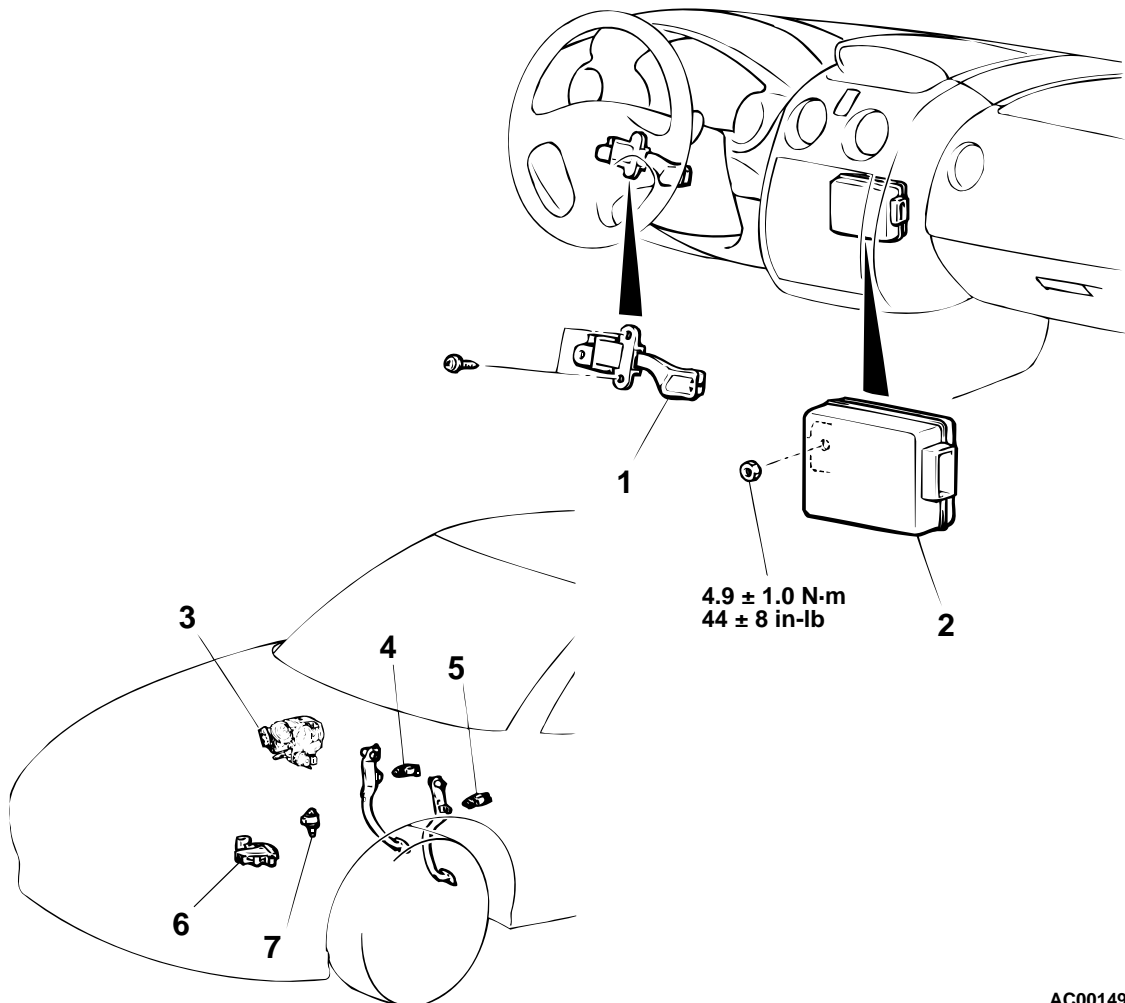

AC001495AC

**CONTROL SWITCH REMOVAL STEPS**

- STEERING WHEEL (REFER TO GROUP 37A, STEERING WHEEL AND SHAFT [P.37A-20.](#))
- 1. AUTO-CRUISE CONTROL SWITCH

**CONTROL UNIT REMOVAL STEPS**

- CENTER PANEL ASSEMBLY (REFER TO GROUP 52A, INSTRUMENT PANEL [P.52A-4.](#))
- 2. AUTO-CRUISE CONTROL-ECU

**SENSOR REMOVAL STEPS**

3. THROTTLE POSITION SENSOR
4. STOPLIGHT SWITCH (REFER TO GROUP 35A, BRAKE PEDAL [P.35A-31.](#))
5. CLUTCH PEDAL POSITION SWITCH (REFER TO GROUP 21A, CLUTCH PEDAL [P.21A-10.](#))
6. PARK/NEUTRAL POSITION SWITCH <A/T>
7. VEHICLE SPEED SENSOR

# EMISSION CONTROL

## GENERAL DESCRIPTION

M1173000100046

The emission control system consists of the following subsystems:

- Evaporative emission control system
- Exhaust emission control system

- Positive crankcase ventilation system

## DIAGNOSIS

M1173000700026

SYMPTOM	PROBABLE CAUSE	REMEDY
Engine will not start or hard to start	Vacuum hose disconnected or damaged	Repair or replace
	The EGR valve is not closed.	Repair or replace
	Malfunction of the evaporative emission purge solenoid	Repair or replace
Rough idle or engine stalls	The EGR valve is not closed.	Repair or replace
	Vacuum hose disconnected or damaged.	Repair or replace
	Malfunction of the positive crankcase ventilation valve	Replace
	Malfunction of the purge control system	Check the system; If there is a problem, check its component parts.
Engine hesitates or poor acceleration	Malfunction of the exhaust gas recirculation system	Check the system; If there is a problem, check its component parts.
Excessive oil consumption	Positive crankcase ventilation line clogged	Check positive crankcase ventilation system
Poor fuel mileage	Malfunction of the exhaust gas recirculation system	Check the system; If there is a problem, check its component parts.

## SPECIAL TOOLS

M1173000600063

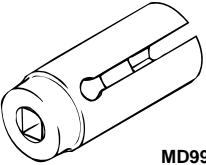
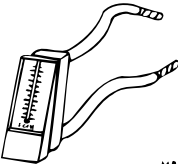
TOOL	TOOL NUMBER AND NAME	SUPERSESSION	APPLICATION
 MD998770	MD998770 Oxygen sensor wrench	MD998770-01 or General service tool	Removal/installation of heated oxygen sensor
 MB991700	MB995061 Purge flow indicator	MLR6890A	Inspection of purge control system

VACUUM HOSES

VACUUM HOSE ROUTING

M1173000900042

<2.4L ENGINE>

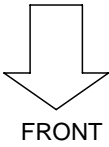
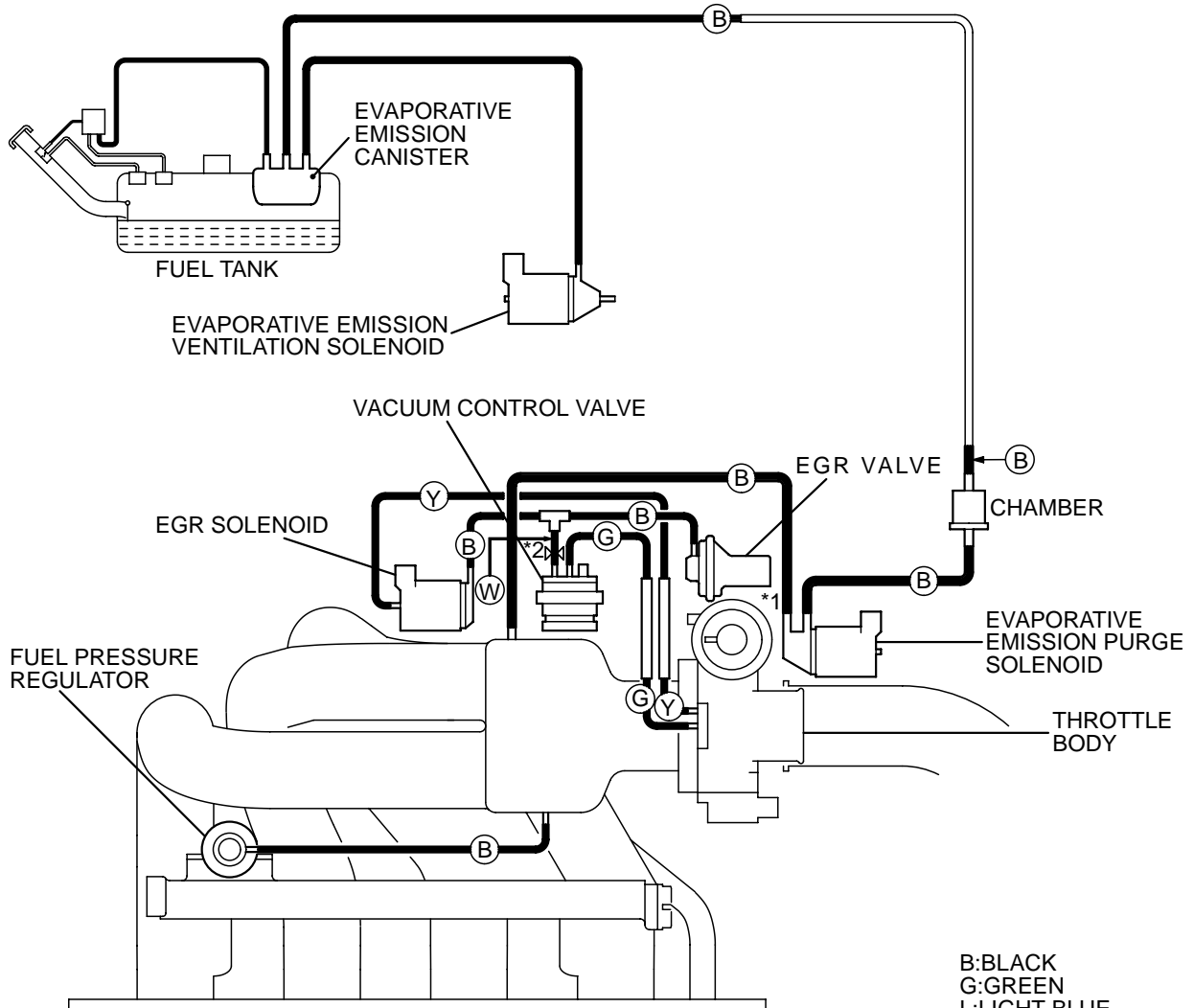

AKX01293 AB

TSB Revision

<3.0L ENGINE>

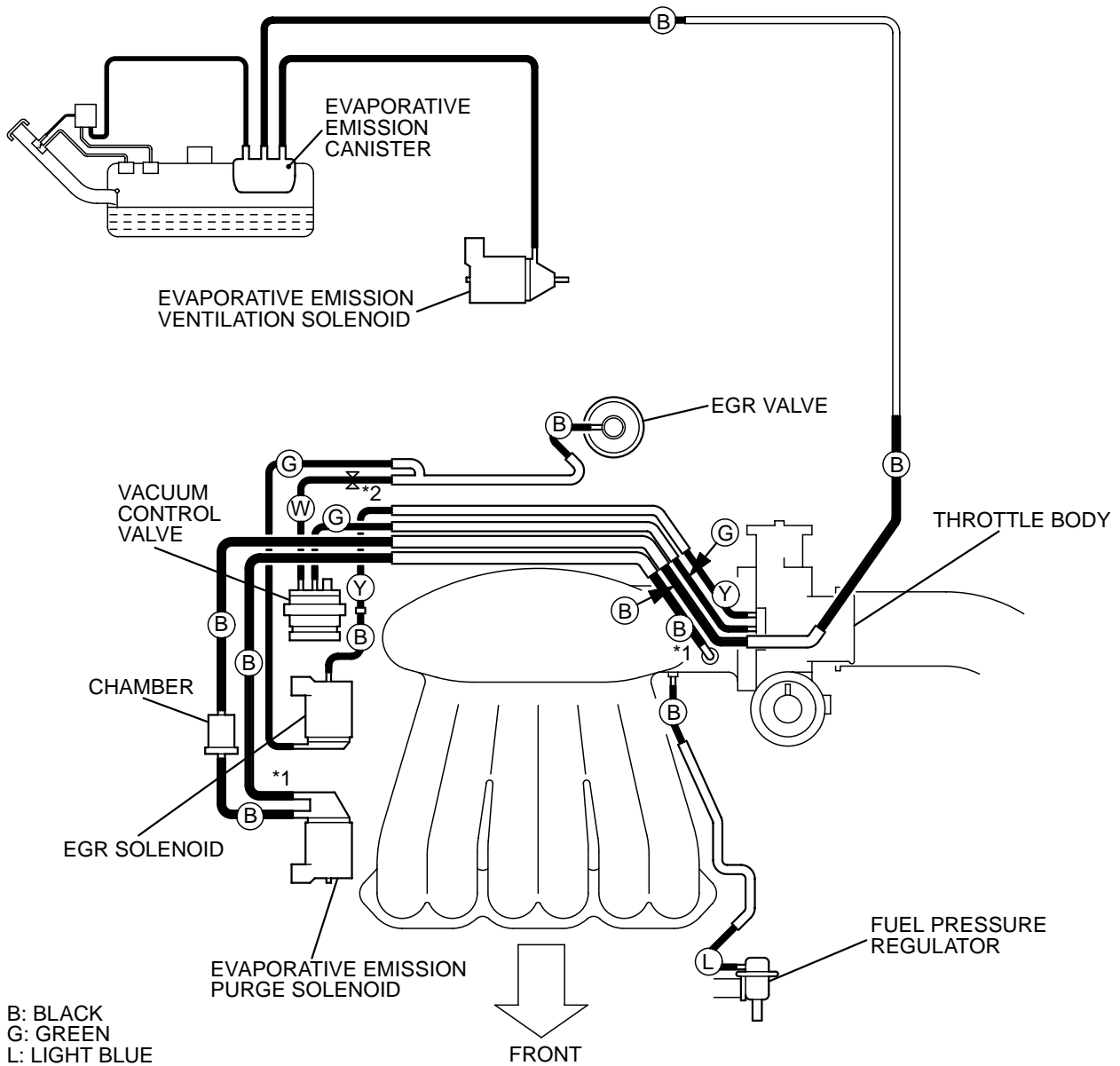

B: BLACK  
G: GREEN  
L: LIGHT BLUE  
W: WHITE  
Y: YELLOW  
\*1: RED PAINT MARK  
\*2: RESTRICTOR

AKX01294 AB

TSB Revision

VACUUM CIRCUIT DIAGRAM

M1173007100025

<2.4L ENGINE>

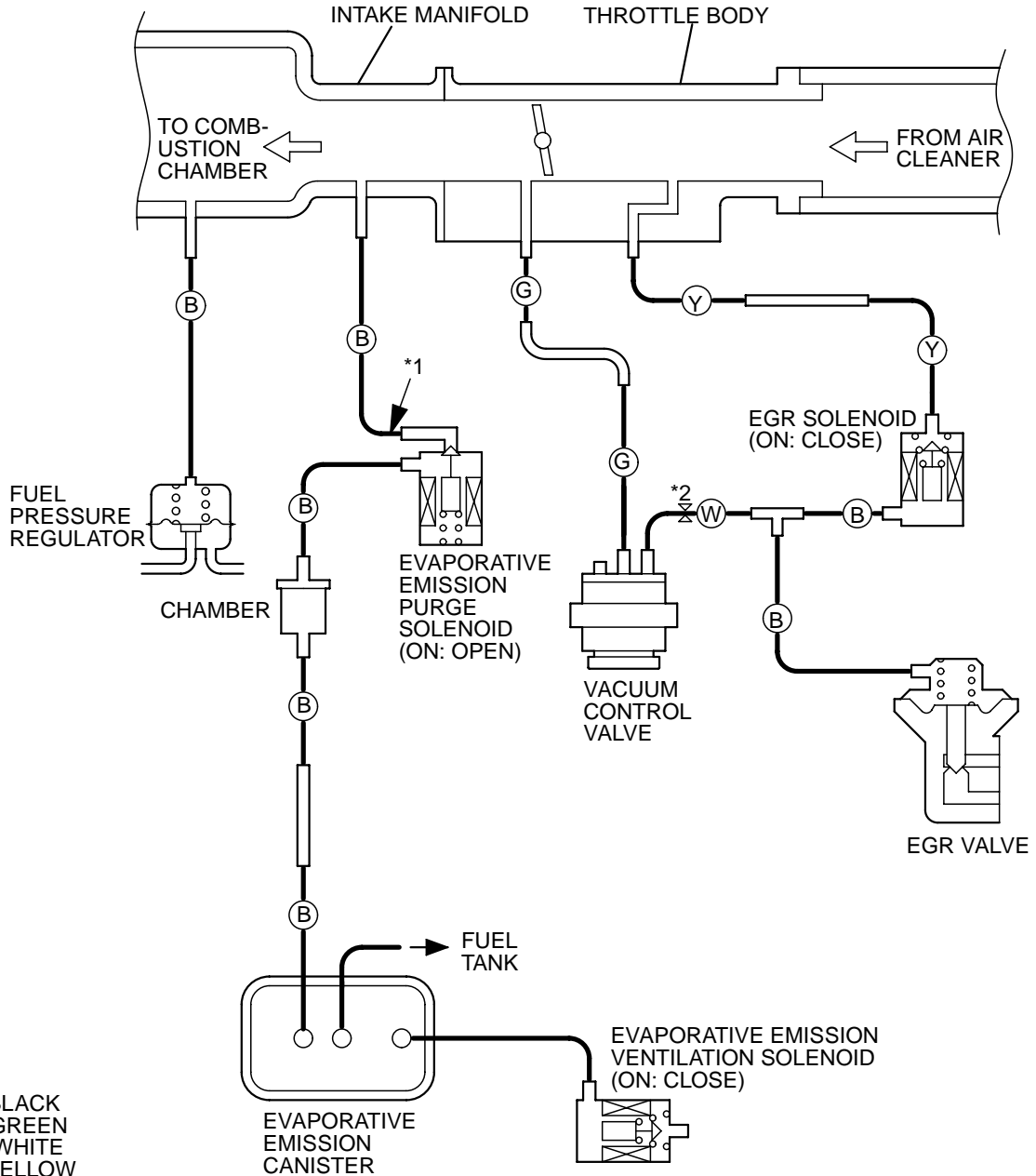

- B: BLACK
- G: GREEN
- W: WHITE
- Y: YELLOW
- \*1: RED PAINT MARK
- \*2: RESTRICTOR

AKX01295 AB

TSB Revision

<3.0L ENGINE>

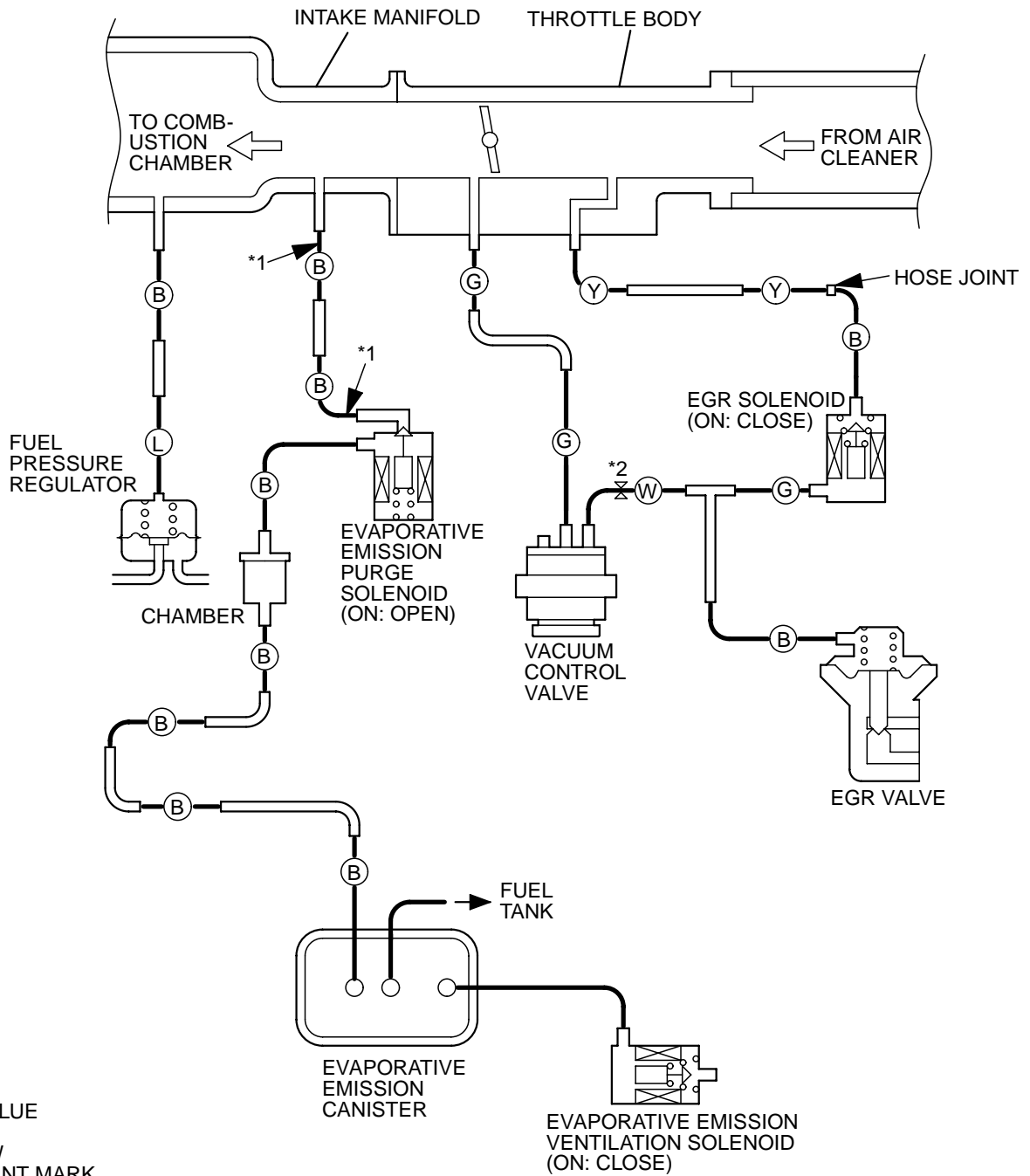

AKX01296 AB

**VACUUM HOSE INSTALLATION**

M1173007200022

1. When connecting the vacuum hoses, they should be securely inserted onto the nipples.
2. Connect the hoses correctly, using the VACUUM HOSE ROUTING as a guide.

TSB Revision

**VACUUM HOSE CHECK**

M1173007300029

1. Using the VACUUM HOSE ROUTING as a guide, check that the vacuum hoses are correctly connected.
2. Check the connection of the vacuum hoses, (removed, loose, etc.) and confirm that there are no sharp bends or damage.

**POSITIVE CRANKCASE VENTILATION SYSTEM****GENERAL DESCRIPTION (POSITIVE CRANKCASE VENTILATION SYSTEM)**

M1173005000044

The positive crankcase ventilation system is a system for preventing the escape of blow-by gases from inside the crankcase into the atmosphere. Fresh air is sent from the air cleaner into the crankcase through the breather hose to be mixed with the blow-by gas inside the crankcase. The blow-by gas inside the crankcase is drawn into the intake manifold through the positive crankcase ventilation (PCV) valve.

The PCV valve is designed to lift the plunger according to the intake manifold vacuum so as to regulate the flow of blow-by gas properly. In other words, the blow-by gas flow is regulated during low load engine operation to maintain engine stability, while the flow is increased during high load operation to improve the ventilation performance.

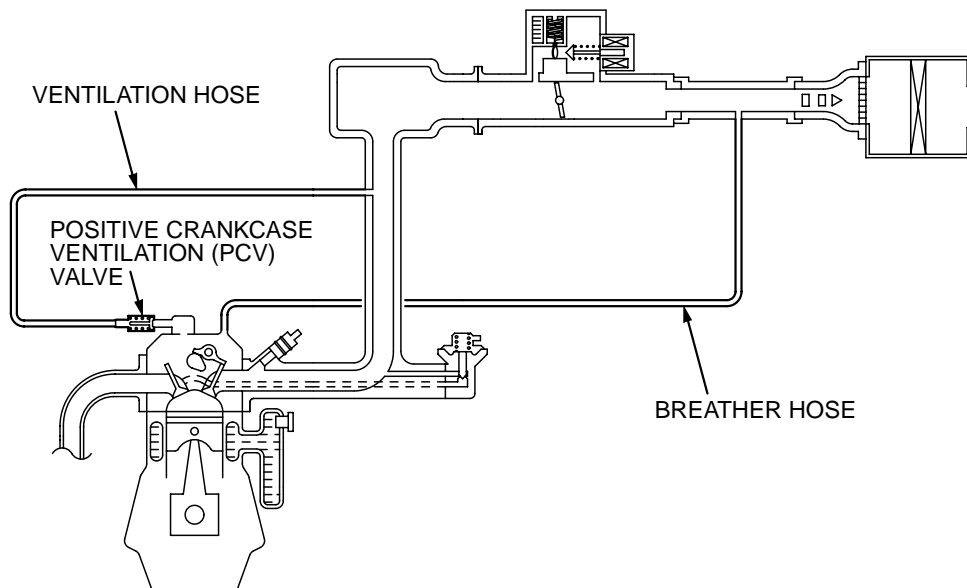
**SYSTEM DIAGRAM****<2.4L ENGINE>**

AKX01297 AB



<3.0L ENGINE>

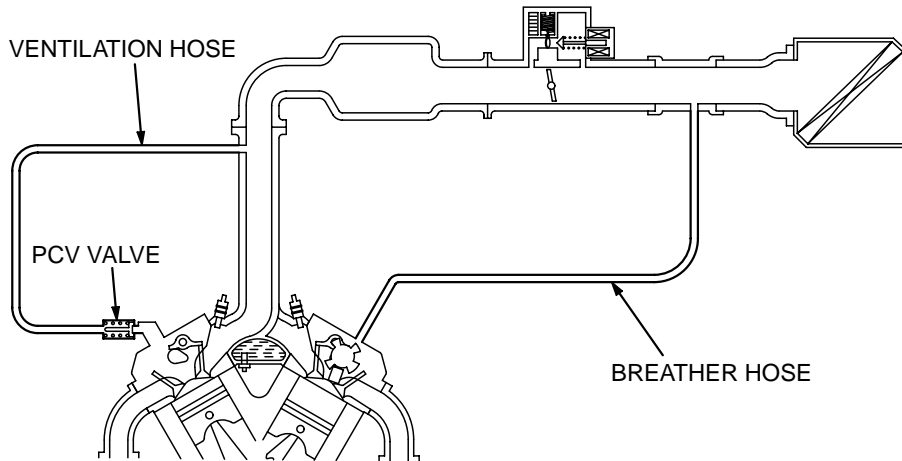

AKX00334 AB

COMPONENT LOCATION

M1173007400026

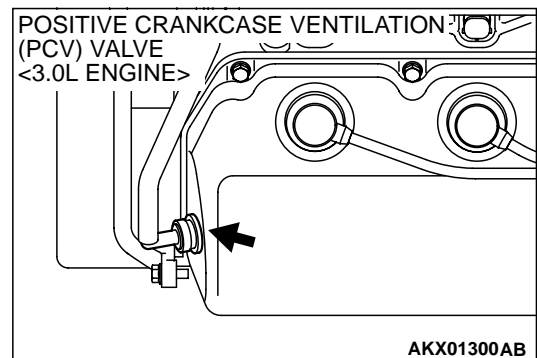
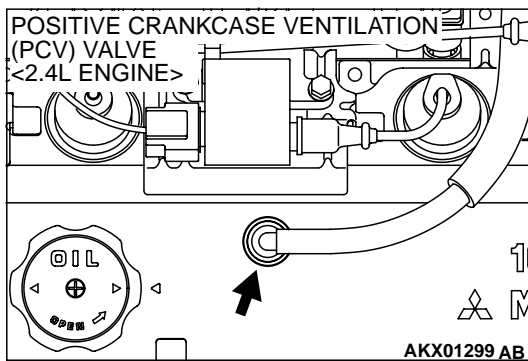

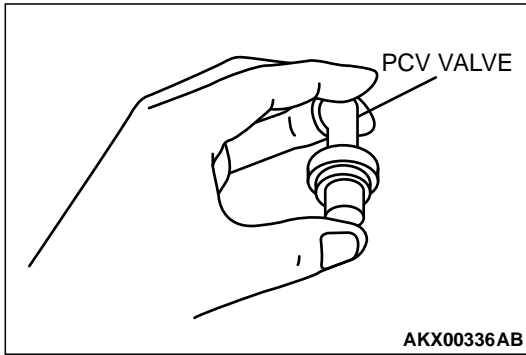

## CRANKCASE VENTILATION SYSTEM CHECK M1173001100049

1. Remove the positive crankcase ventilation (PCV) valve from the rocker cover, then reconnect the PCV valve to the vacuum supply hose.
2. With the engine idling, put your finger on the open end of the PCV valve, and check for negative pressure (vacuum).  
*NOTE: At this time, the plunger in the PCV valve should move back and forth as the open end is covered and uncovered.*
3. If negative pressure is not felt, clean or replace the PCV valve. Inspect the vacuum supply hose and vacuum supply hose port for restriction or plugged condition.

## POSITIVE CRANKCASE VENTILATION (PCV) VALVE CHECK M1173001200046

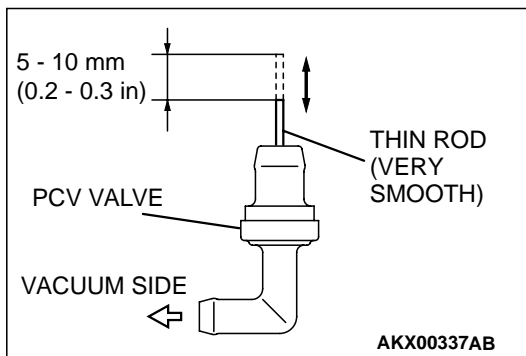

1. Hold the PCV valve with the vacuum side down. Insert a thin rod, and using light pressure, depress the end of the PCV valve spring by 5 – 10 mm (0.2 – 0.3 inch). Release pressure on the rod to see if the PCV valve spring will lift the rod to its original position.
2. If the rod returns quickly to its original position, the PCV valve is OK. If the stick does not return quickly, clean or replace the PCV valve.

## EVAPORATIVE EMISSION CONTROL SYSTEM

### GENERAL DESCRIPTION

The evaporative emission control system prevents fuel vapors generated in the fuel tank from escaping into the atmosphere.

Fuel vapors from the fuel tank flow through the vapor pipe/hose to be stored temporarily in the evaporative emission (EVAP) canister.

When the vehicle is in operation, fuel vapors stored in the EVAP canister flow through the chamber, the EVAP purge solenoid, purge port and intake manifold plenum to the combustion chamber.

When the engine coolant temperature is low or when the intake air quantity is small (when the engine is at idle, for example), the engine control module brings the EVAP purge solenoid into the OFF state to shut off the fuel vapor flow to the intake manifold plenum. This ensures driveability when the engine is cold or running under low load and also stabilizes the emission level.

An EVAP ventilation solenoid is provided between the EVAP canister and atmosphere to monitor for OBD-II EVAP leaks. This solenoid is normally OFF. However, it turns ON when monitoring the OBD-II EVAP leaks and shuts off the atmosphere flow to the EVAP canister. Then the fuel tank differential pressure sensor monitors the fuel vapor pressure to detect OBD-II EVAP leaks. The fuel vent valve and the leveling valve prevent fuel from being overfilled. The fuel vent valve and the leveling valve prevents fuel leaks just if the vehicle is rolled over in an accident.

The vent valve releases the air from the fuel tank through the evaporative emission canister into the atmosphere when the fuel tank pressure increases due to refueling, etc. The vent valve and the air filter supply the atmospheric air to the evaporative emission canister when the fuel tank pressure decreases.

SYSTEM DIAGRAM

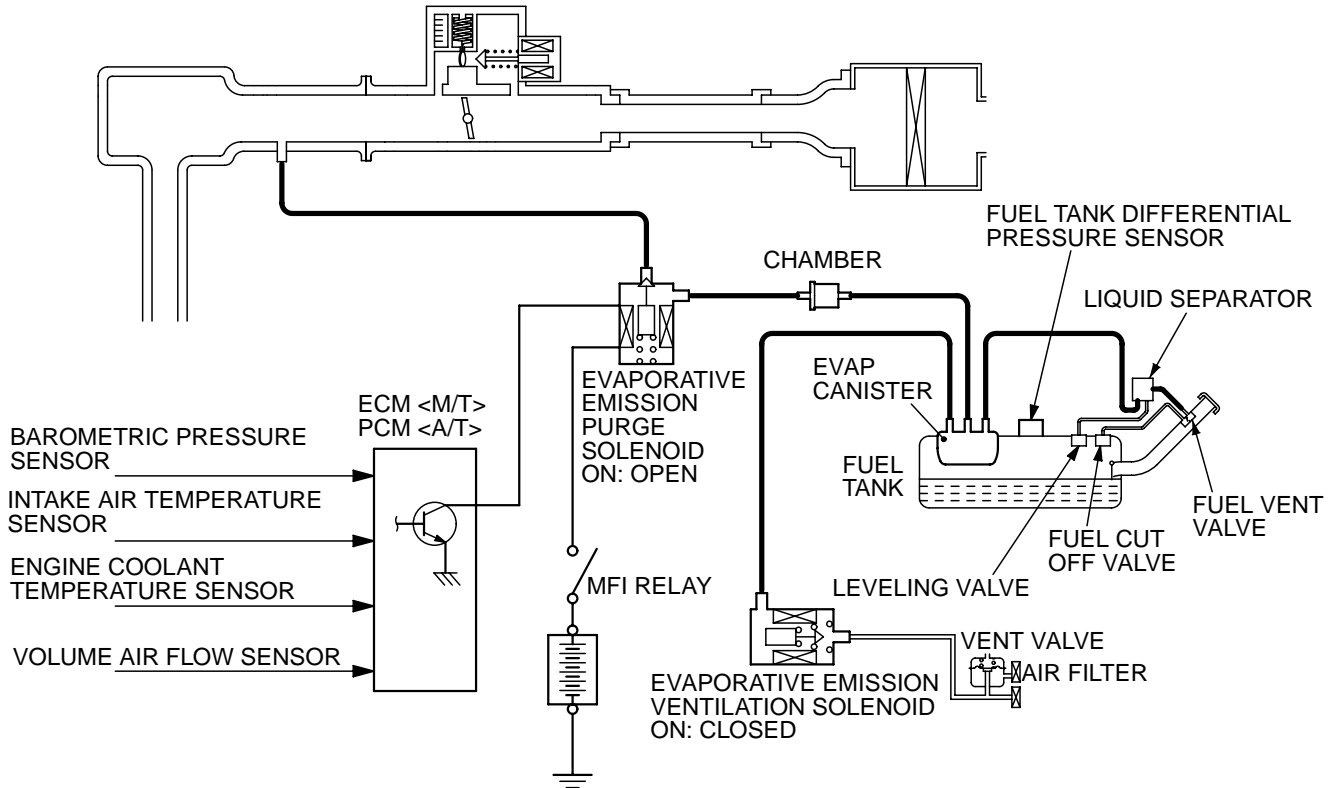

AKX01303 AB

COMPONENT LOCATION

M1173007500023

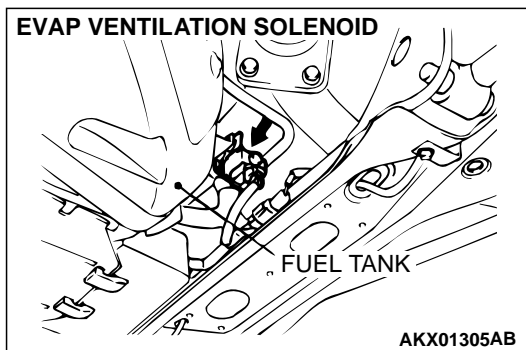
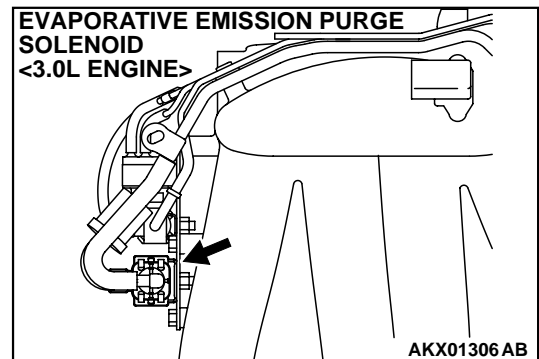
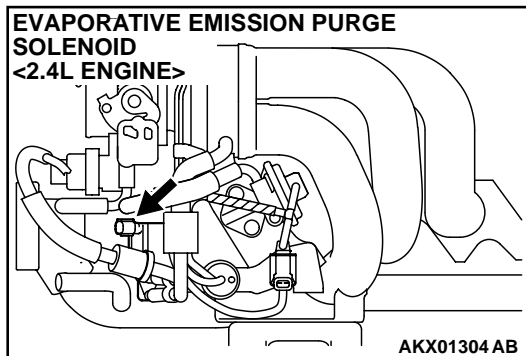

TSB Revision

## PURGE CONTROL SYSTEM CHECK (PURGE FLOW CHECK)

M1173001400040

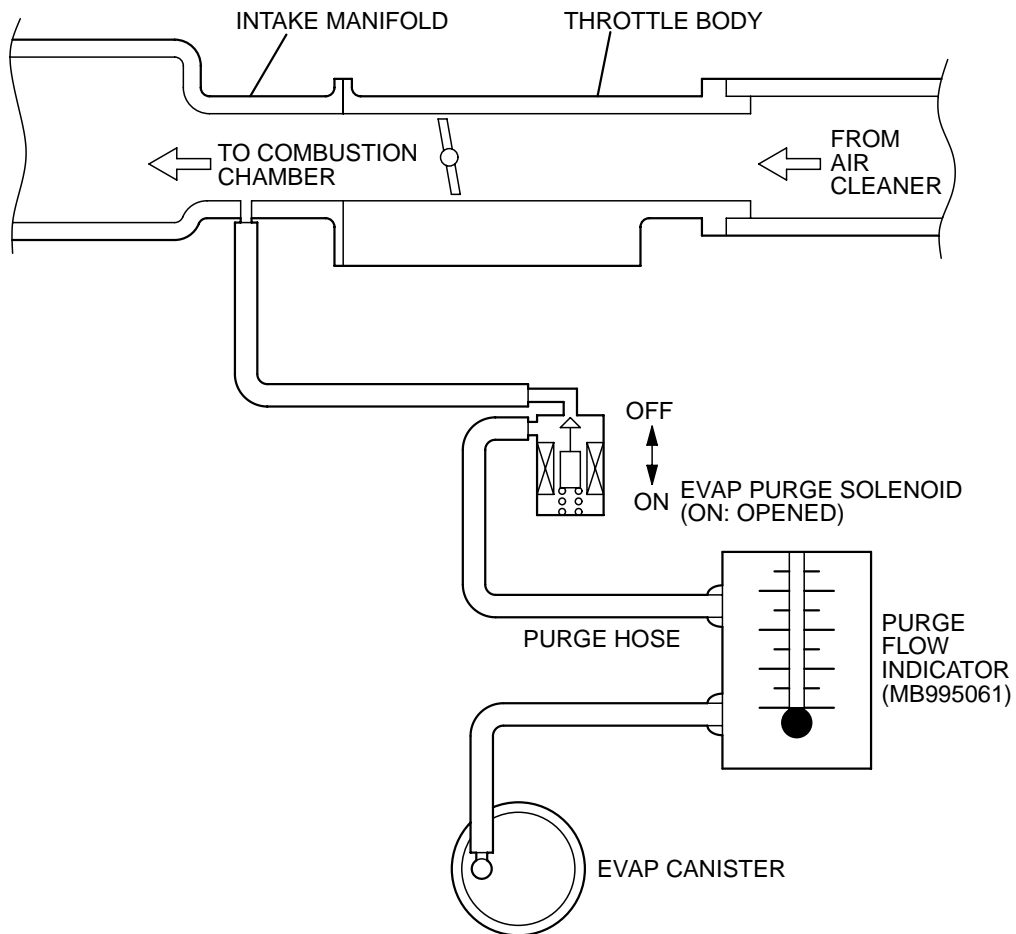

AKX00340AB

**Required Special Tool:**

MB995061: Purge Flow Indicator

1. Disconnect the purge hose from the evaporative emission (EVAP) purge solenoid, and connect special tool MB995061 between the EVAP purge solenoid and the purge hose.
2. Before inspection and adjustment, set the vehicle in the following conditions:
  - Engine coolant temperature: 80 – 95°C (176 – 203°F)
  - Lights, electric cooling fan and accessories: OFF
  - Transaxle: Neutral (A/T – P range)
3. Run the engine at idle for more than four minutes.
4. Check the purge flow volume when engine is revved suddenly several times.

**Standard value: Momentarily 20 cm<sup>3</sup>/s (2.5 SCFH) or more.**

- If the purge flow volume is less than the standard value, check it again with the vacuum hose disconnected from the EVAP canister. If the purge flow volume is less than the standard value, check the vacuum port and the vacuum hose for clogging. Also check the evaporative emission purge solenoid. If the purge flow volume is at the standard value, replace the EVAP canister.

### EVAPORATIVE EMISSION PURGE SOLENOID CHECK

M1173001700041

- Remove the air intake hose <2.4L Engine>.
- Disconnect the vacuum hose (black, black with red paint mark) from the EVAP purge solenoid.  
*NOTE: When disconnecting the vacuum hose, always place an identification mark so that it can be reconnected at its original position.*
- Disconnect the harness connector.
- Connect a hand vacuum pump to nipple (A) of the EVAP purge solenoid (refer to the illustration at left).
- Check airtightness by applying a vacuum with voltage applied directly from the battery to the EVAP purge solenoid valve and without applying voltage.

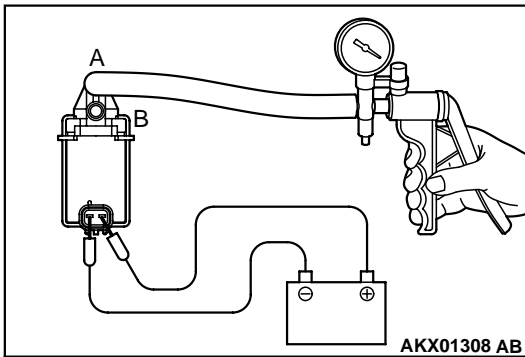

BATTERY POSITIVE VOLTAGE	NORMAL CONDITION
Applied	Vacuum leaks
Not applied	Vacuum maintained

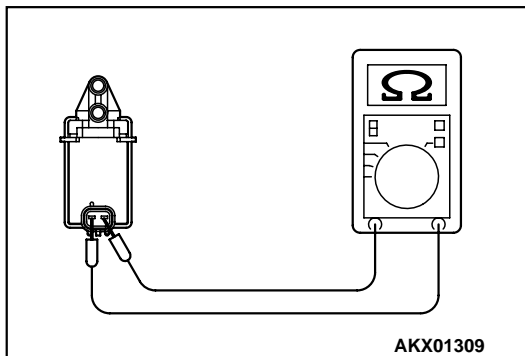

- Measure the resistance between the terminals of the EVAP purge solenoid.  
**Standard value: 30 – 34 Ω [at 20°C (68°F)]**
- Replace solenoid if resistance is out of specification.

### CHAMBER CHECK

M1173008400030

Remove the vacuum hose and chamber assembly, and check that the assembly is not clogged by blowing it.

### VOLUME AIR FLOW SENSOR CHECK

M1173007900076

#### <2.4L ENGINE>

To inspect the sensor, refer to GROUP 13A (2.4L), Multiport Fuel Injection (MFI) Diagnosis - Diagnostic Trouble Code Chart [P.13A-20](#).

**<3.0L ENGINE>**

To inspect the sensor, refer to GROUP 13B (3.0L), Multiport Fuel Injection (MFI) Diagnosis - Diagnostic Trouble Code Chart [P.13B-18](#).

**BAROMETRIC PRESSURE SENSOR CHECK**

M1173008000043

**<2.4L ENGINE>**

To inspect the sensor, refer to GROUP 13A (2.4L), Multiport Fuel Injection (MFI) Diagnosis - Diagnostic Trouble Code Chart [P.13A-20](#).

**<3.0L ENGINE>**

To inspect the sensor, refer to GROUP 13B (3.0L), Multiport Fuel Injection (MFI) Diagnosis - Diagnostic Trouble Code Chart [P.13B-18](#).

**ENGINE COOLANT TEMPERATURE SENSOR CHECK**

M1173008100073

**<2.4L ENGINE>**

To inspect the sensor, refer to GROUP 13A (2.4L), Multiport Fuel Injection (MFI) Diagnosis - Diagnostic Trouble Code Chart [P.13A-20](#).

**<3.0L ENGINE>**

To inspect the sensor, refer to GROUP 13B (3.0L), Multiport Fuel Injection (MFI) Diagnosis - Diagnostic Trouble Code Chart [P.13B-18](#).

**INTAKE AIR TEMPERATURE SENSOR CHECK**

M1173008200047

**<2.4L ENGINE>**

To inspect the sensor, refer to GROUP 13A (2.4L), Multiport Fuel Injection (MFI) Diagnosis - Diagnostic Trouble Code Chart [P.13A-20](#).

**<3.0L ENGINE>**

To inspect the sensor, refer to GROUP 13B (3.0L), Multiport Fuel Injection (MFI) Diagnosis - Diagnostic Trouble Code Chart [P.13B-18](#).

**FUEL TANK DIFFERENTIAL PRESSURE SENSOR CHECK**

M1173007700050

To inspect the sensor, refer to GROUP 13C, Fuel Supply Fuel Tank – Fuel Tank Differential Pressure Sensor Check [P.13C-11](#).

---

**EVAPORATIVE EMISSION VENTILATION  
SOLENOID CHECK**

M1173007800057

Refer to Evaporative Emission Canister And Fuel Tank  
Pressure Relief Valve – Fuel Tank Pressure Relief Valve  
Inspection [P.17-103](#).

TSB Revision

**EXHAUST GAS RECIRCULATION (EGR) SYSTEM**

**GENERAL DESCRIPTION**

M1173005200048

The exhaust gas recirculation (EGR) system lowers the oxides of nitrogen (NOx) emission level. When the air/fuel mixture combustion temperature is high, a large quantity of NOx is generated in the combustion chamber. Therefore, this system recirculates part of exhaust gas from the exhaust port of the cylinder head to the combustion chamber through the intake manifold to decrease the air/fuel mixture combustion temperature, resulting in reduction of NOx.

The EGR flow rate is controlled by the EGR valve so as not to decrease the driveability.

**OPERATION**

When the engine coolant temperature is low, when the engine is at idle or when a wide open throttle operation is performed, the EGR valve is kept closed, achieving no EGR. After warming up of the engine, the EGR valve can be opened by the engine control module.

The engine control module monitors the EGR system and illuminates the check engine/malfunction indicator lamp to indicate that there is a malfunction.

**SYSTEM DIAGRAM**

**<2.4L ENGINE>**

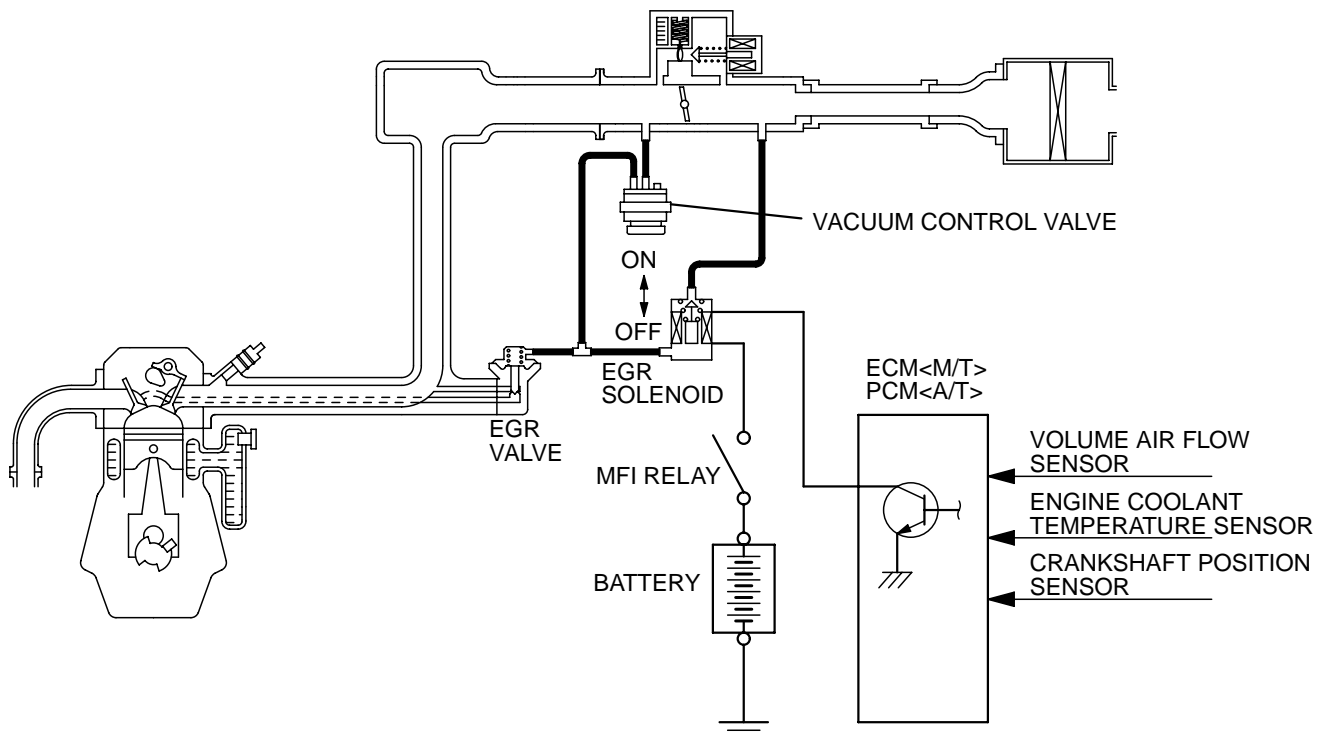

AKX01310 AB



<3.0L ENGINE>

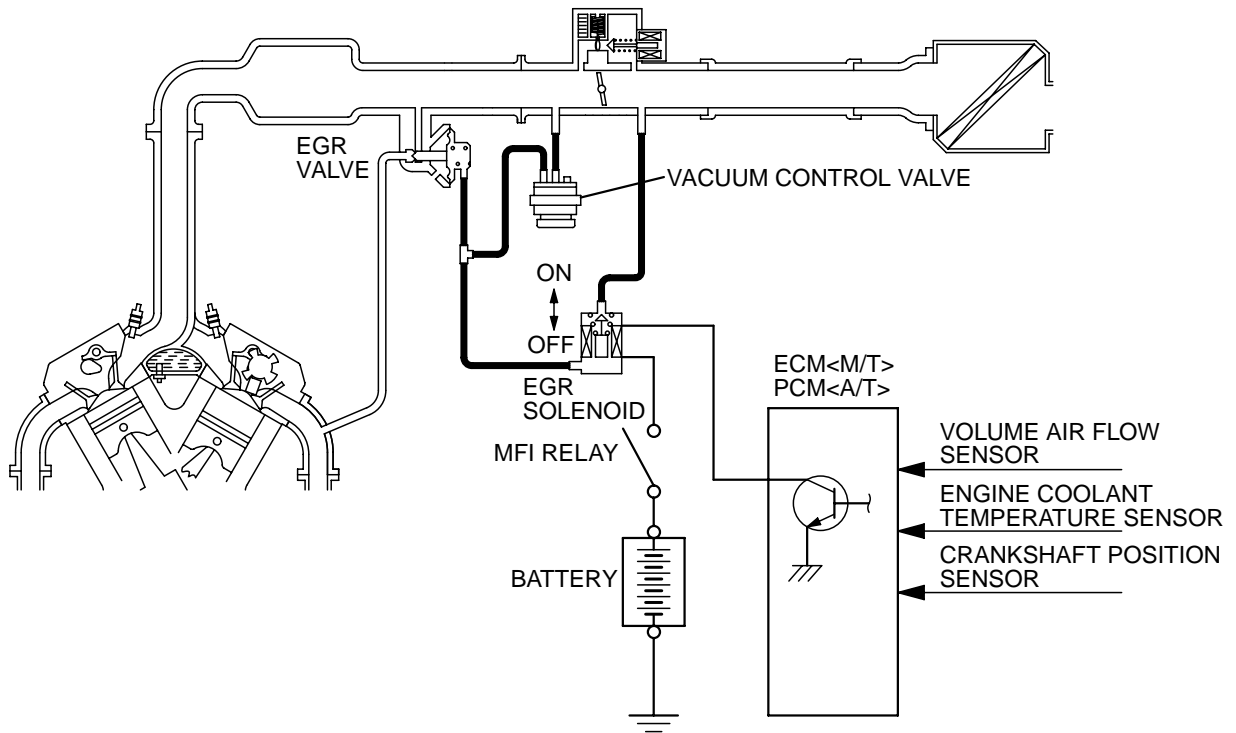

AKX00353AC

COMPONENT LOCATION

M1173007600020

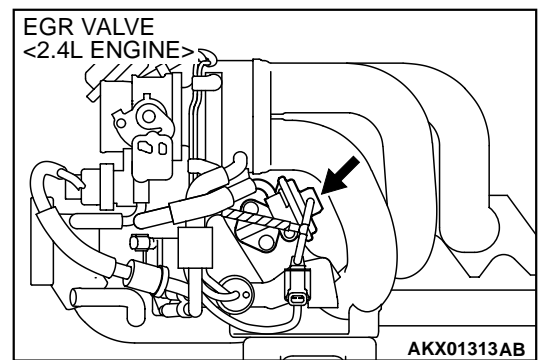
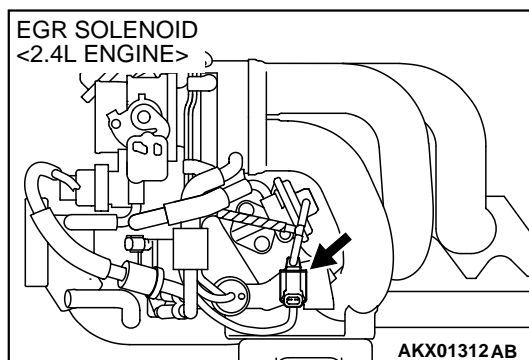

TSB Revision

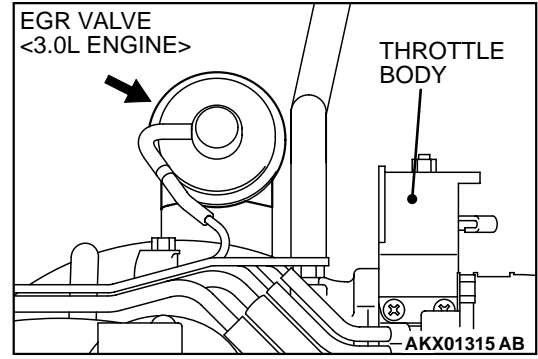
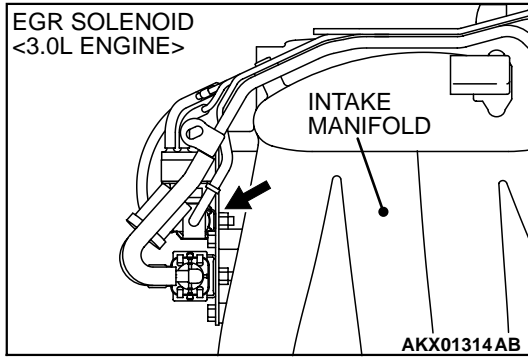

**EGR SYSTEM CHECK**

M1173002600058

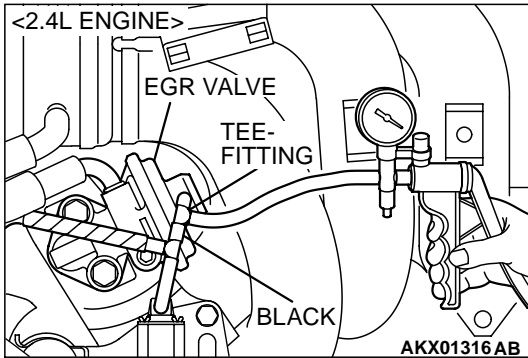

1. Disconnect the vacuum hose (black) from the EGR valve, and then connect a hand vacuum pump via the Tee-fitting.
2. Start the engine. Check the vacuum condition when the throttle valve is opened suddenly (revving) during cold and hot engine conditions. If the engine is hot and the vacuum does not rise over 13 kPa (3.9 in Hg), perform the vacuum control valve check and EGR port vacuum check. Then continue to Step 3. If vacuum rises momentarily, proceed to Step 3.

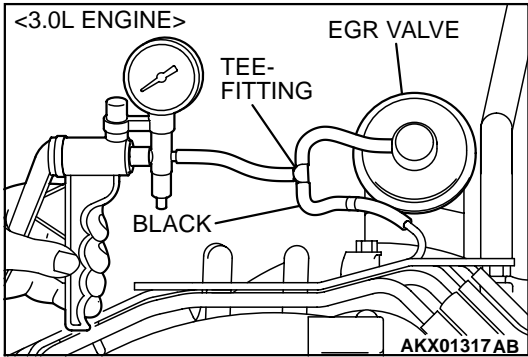

**When engine is cold**

**[Engine coolant temperature: 20°C (68°F) or less]**

THROTTLE VALVE	NORMAL VACUUM CONDITION
Open quickly	No vacuum (Remained as barometric pressure).

**When engine is hot**

**[Engine coolant temperature: 80°C (176°F) or more]**

THROTTLE VALVE	NORMAL VACUUM CONDITION
Open quickly	Momentarily rises over 13 kPa (3.9 in Hg)

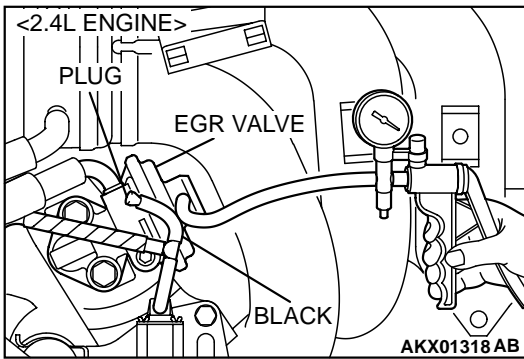

3. Stop the engine. Remove the Tee-fitting and the hand vacuum pump.
4. Connect the hand vacuum pump directly to the EGR valve.
5. Start the engine and run at idle until warm.
6. The engine idling speed should be rough when a vacuum of 29 kPa (8.7 in Hg) or more is applied to the EGR valve.
7. If engine idles rough, EGR passage is open and the system is OK. If engine idle is not rough, the EGR passage and the valve must be checked for restrictions. Perform the EGR valve check. Then repeat the EGR system check.

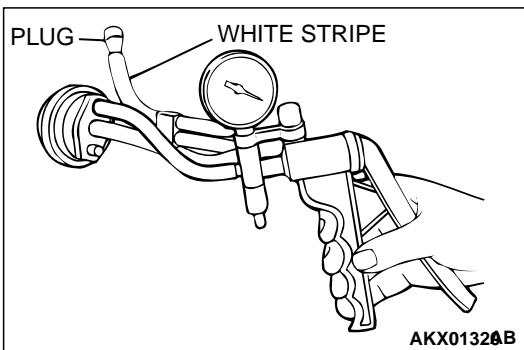
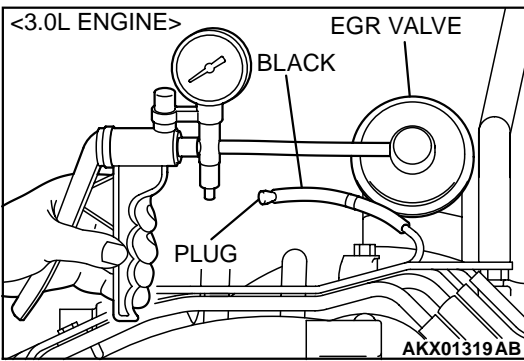

### VACUUM CONTROL VALVE CHECK

M1173002700044

1. Disconnect the vacuum hose (white stripe) from the vacuum control valve and connect the hand vacuum pump to the vacuum control valve.
2. Plug the end of the removed vacuum hose.
3. Start the engine and run at idle.
4. Check the vacuum condition.

ENGINE CONDITION	NORMAL VACUUM CONDITION
Idling	Approximately 21.3 – 24.0 kPa (6.3 - 7.1 in Hg)

### EGR VALVE CHECK

M1173002800041

1. Remove the EGR valve and inspect for sticking, carbon deposits, etc. If found, clean with a suitable solvent so that the valve seats correctly.
2. Connect a hand vacuum pump to the EGR valve.
3. Apply 67 kPa (20 in Hg) of vacuum, and check to be sure that the vacuum is maintained.
4. Apply a vacuum and check the passage of air by blowing through one side of the EGR passage.

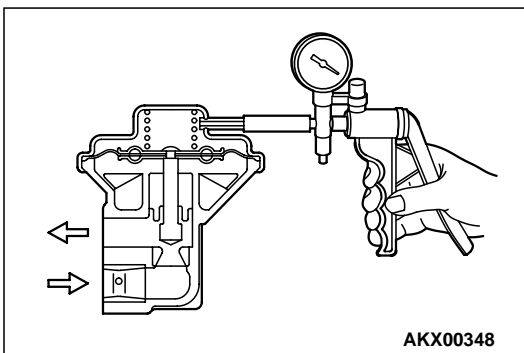

VACUUM	PASSAGE OF AIR
5.3 kPa (1.6 in Hg) or less	Air is not blown out
29 kPa (8.7 in Hg) or more	Air is blown out

*NOTE: Passage of air should be checked by blowing the valve port.*

- Reinstall the EGR valve, using a new gasket, and tighten to the specified torque.

**Tightening torque:**

**<2.4L engine> 19 ± 3 N·m (14 ± 2 ft·lb)**

**<3.0L engine> 22 ± 4 N·m (16 ± 3 ft·lb)**

**EGR PORT VACUUM CHECK**

M1173002900048

- Disconnect the vacuum hose (green stripe) from the throttle body EGR vacuum nipple and connect a hand vacuum pump to the nipple.

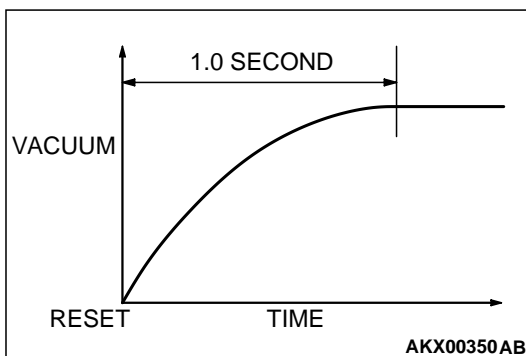
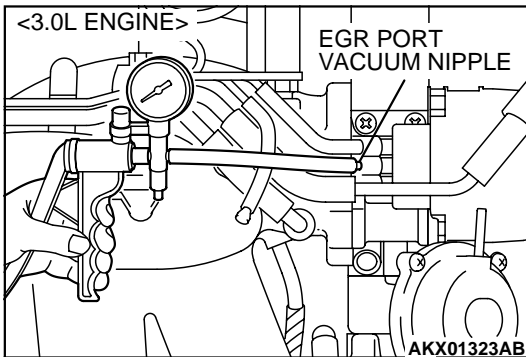
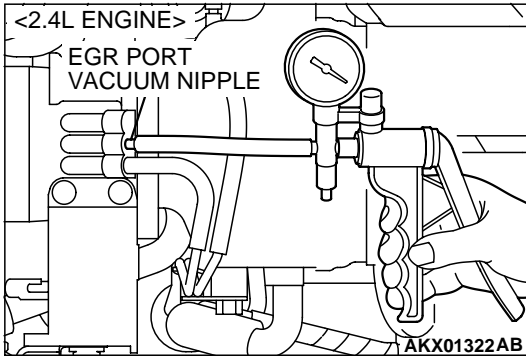

- Start the engine.
- Measure engine vacuum at idle.  
**Standard value: 51 kPa (15 in Hg) or more**
- Reset the vacuum pump to "0" (Release vacuum).
- Using a stop watch, measure how long it takes for the vacuum gauge to reach 51 kPa (15 in Hg).  
**Standard value: 1.0 second or less**
- If it takes more than 1.0 second for the gauge to reach 51 kPa (15 in Hg), the EGR may be restricted and should be cleaned.

**EGR SOLENOID CHECK**

M1173003100045

- Disconnect the vacuum hose from the EGR solenoid.  
*NOTE: When disconnecting the vacuum hose, always make sure that it can be reconnected at its original position.*
- Disconnect the harness connector.

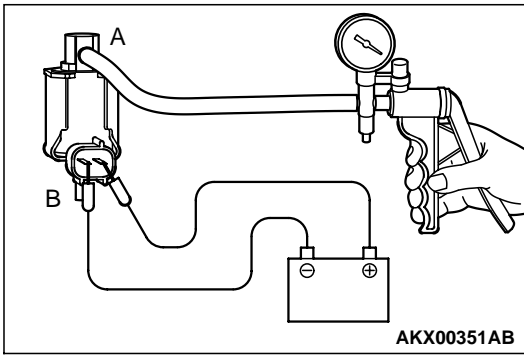

3. Connect a hand vacuum pump to nipple (A) of the EGR solenoid. (Refer to the illustration at left.)
4. Check airtightness by applying a vacuum with voltage applied directly from the battery to the EGR solenoid and without applying voltage.

BATTERY POSITIVE VOLTAGE	NORMAL CONDITION
Not applied	Vacuum leaks
Applied	Vacuum maintained

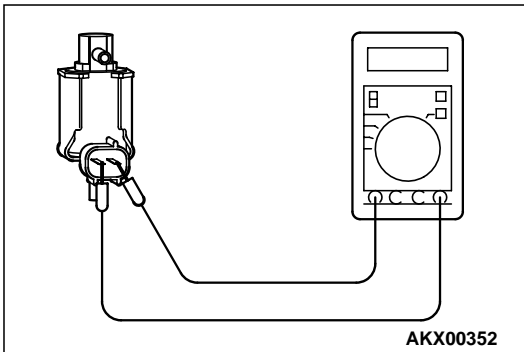

5. Measure the resistance between the terminals of the EGR solenoid.

**Standard value: 29 – 35 Ω [at 20°C (68°F)]**

6. Replace the solenoid if resistance is out of specification.

## VOLUME AIR FLOW SENSOR CHECK

M1173007900087

### <2.4L ENGINE>

To inspect the sensor, refer to GROUP 13A (2.4L), Multiport Fuel Injection (MFI) Diagnosis - Diagnostic Trouble Code Chart [P.13A-20](#).

### <3.0L ENGINE>

To inspect the sensor, refer to GROUP 13B (3.0L), Multiport Fuel Injection (MFI) Diagnosis - Diagnostic Trouble Code Chart [P.13B-18](#).

## ENGINE COOLANT TEMPERATURE SENSOR CHECK

M1173008100084

### <2.4L ENGINE>

To inspect the sensor, refer to GROUP 13A (2.4L), Multiport Fuel Injection (MFI) Diagnosis - Diagnostic Trouble Code Chart [P.13A-20](#).

### <3.0L ENGINE>

To inspect the sensor, refer to GROUP 13B (3.0L), Multiport Fuel Injection (MFI) Diagnosis - Diagnostic Trouble Code Chart [P.13B-18](#).

**CRANKSHAFT POSITION SENSOR CHECK**

M1173008300044

**<2.4L ENGINE>**

To inspect the sensor, refer to GROUP 13A (2.4L), Multiport Fuel Injection (MFI) Diagnosis - Diagnostic Trouble Code Chart P.13A-20.

**<3.0L ENGINE>**

To inspect the sensor, refer to GROUP 13B (3.0L), Multiport Fuel Injection (MFI) Diagnosis - Diagnostic Trouble Code Chart P.13B-18.

**EVAPORATIVE EMISSION CANISTER AND FUEL TANK PRESSURE RELIEF VALVE**

**REMOVAL AND INSTALLATION**

M1173004800081

**Pre-removal and Post-installation Operation**  
Fuel Tank Assembly Removal and Installation (Refer to GROUP 13C P.13C-6.)

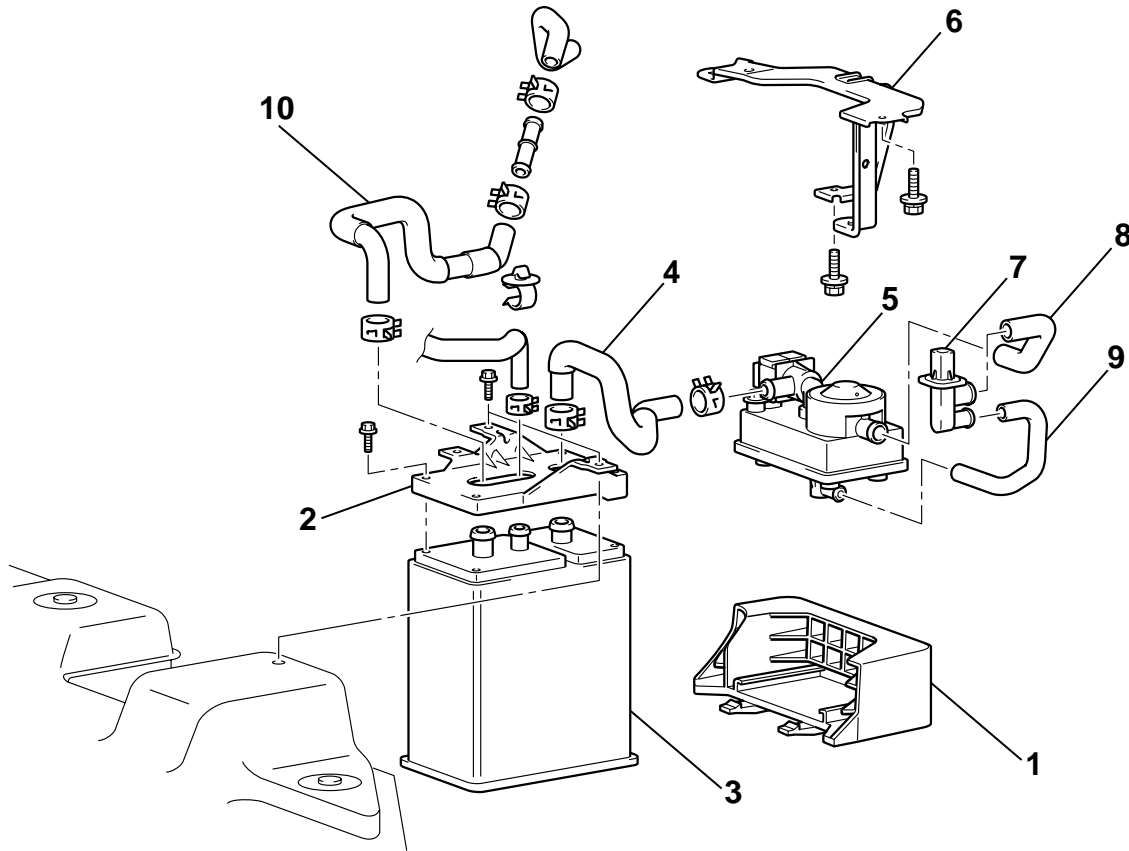

AC002235AB

**REMOVAL STEPS**

1. PROTECTOR
2. CANISTER UPPER BRACKET
3. CANISTER ASSEMBLY
4. VENT HOSE
5. OVER VENT VALVE MODULE

**REMOVAL STEPS (Continued)**

6. BRACKET
7. VENT PIPE
8. VENT HOSE
9. VENT HOSE
10. VAPOR HOSE

TSB Revision

## INSPECTION

### ORVR VENT VALVE MODULE CHECK

1. Blow air through over vent valve module nipple (A). Check that the air flows out of nipple (B) and nipple (C).

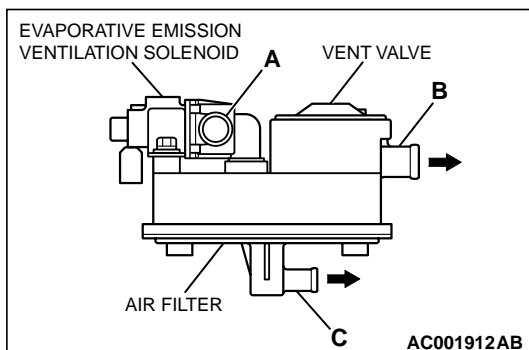

2. Connect a hand vacuum pump to nipple (A) of the over vent valve module.
3. With air flow through nipple (C) obstructed, apply a vacuum and check that the vacuum is maintained.

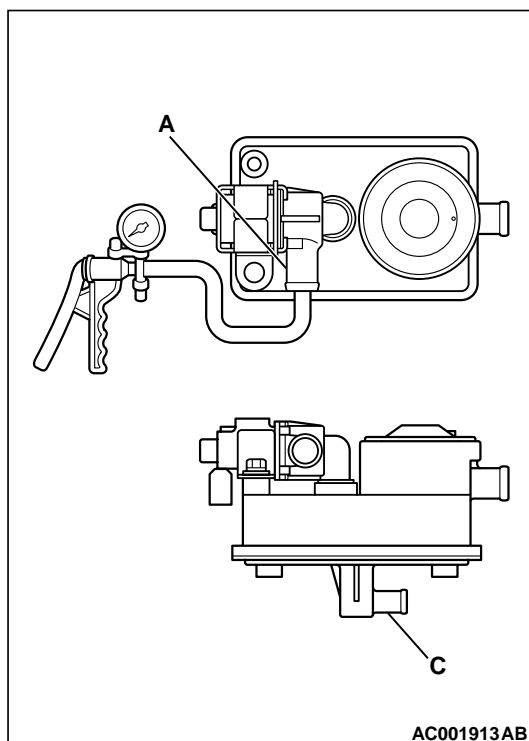

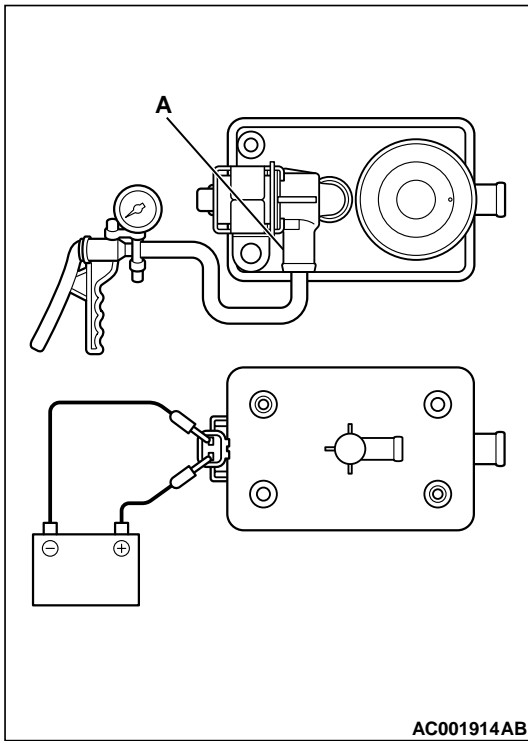

4. Check air tightness by applying a vacuum with voltage applied directly from the battery to the over vent valve module and without applying voltage.

BATTERY VOLTAGE	NORMAL CONDITION
Applied	Vacuum maintained
Not applied	Vacuum leaks

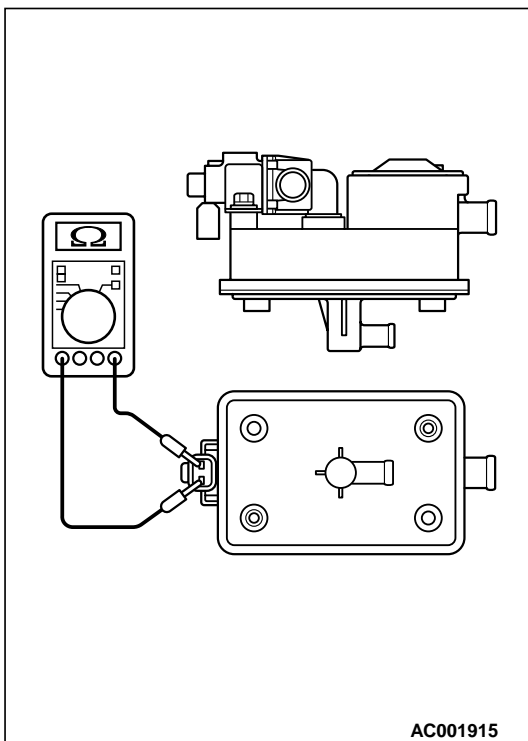

5. Measure the resistance between the terminals of the solenoid.  
**Standard value: 17 – 21 Ω [at 20°C (68°F)]**
6. Replace over vent valve module if resistance is out of specification.



## CATALYTIC CONVERTER

### GENERAL DESCRIPTION (CATALYTIC CONVERTER)

The three-way catalytic converter, together with the closed loop air-fuel ratio control based on the oxygen sensor signal, oxidizes carbon monoxides (CO) and hydrocarbons (HC) and reduces nitrogen oxides (NOx).

When the mixture is controlled at stoichiometric air-fuel ratio, the three-way catalytic converter provides the highest purification against the three constituents, namely, CO, HC and NOx.

M1173005300090

### REMOVAL AND INSTALLATION

M1173003900085

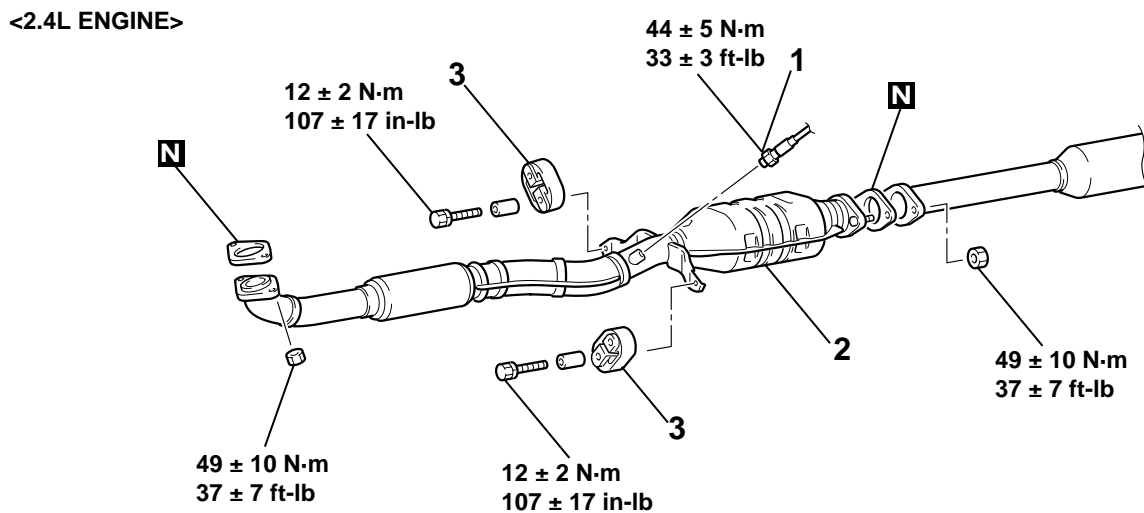

AC004608AC

<<A>> >>A<<

#### REMOVAL STEPS

1. HEATED OXYGEN SENSOR (REAR)

#### REMOVAL STEPS (Continued)

2. FRONT EXHAUST PIPE (CATALYTIC CONVERTER INCORPORATED)
3. HANGER

<3.0L ENGINE>

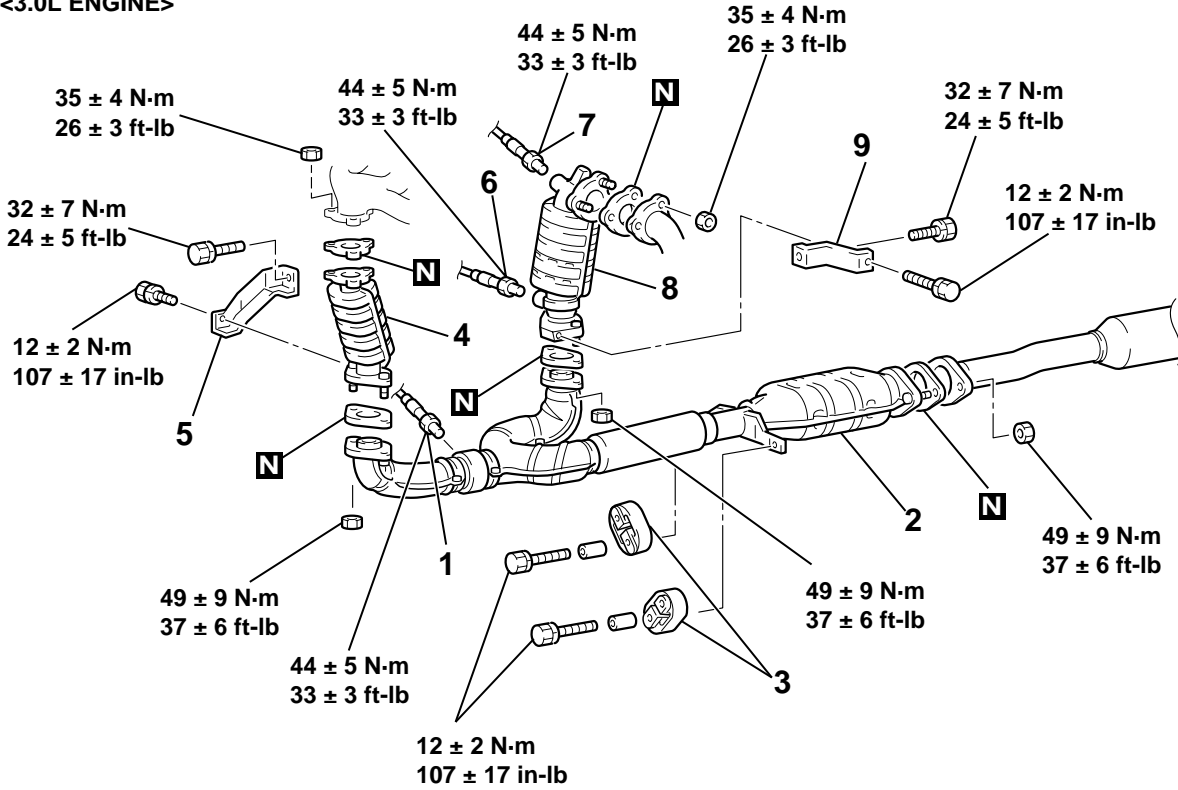

AC005045AC

**FRONT CATALYTIC  
CONVERTER (LH) REMOVAL  
STEPS**

- <<A>> >>A<<
1. LEFT BANK HEATED OXYGEN SENSOR (REAR)
  2. FRONT EXHAUST PIPE (CATALYTIC CONVERTER INCORPORATED)
  3. HANGER
  4. FRONT CATALYTIC CONVERTER (LH)
  5. EXHAUST FITTING STAY (LH)

**FRONT CATALYTIC  
CONVERTER (RH) REMOVAL  
STEPS**

- <<A>> >>A<<
1. LEFT BANK HEATED OXYGEN SENSOR (REAR)
  2. FRONT EXHAUST PIPE (CATALYTIC CONVERTER INCORPORATED)
  3. HANGER
  6. RIGHT BANK HEATED OXYGEN SENSOR (REAR)
  7. RIGHT BANK HEATED OXYGEN SENSOR (FRONT)
  8. FRONT CATALYTIC CONVERTER (RH)
  9. EXHAUST FITTING STAY (RH)

### REMOVAL SERVICE POINT

<<A>> HEATED OXYGEN SENSOR (REAR)/LEFT BANK  
HEATED OXYGEN SENSOR (REAR)/RIGHT BANK HEATED  
OXYGEN SENSOR (REAR)/RIGHT BANK HEATED OXYGEN  
SENSOR (FRONT) REMOVAL

Use special tool MD998770 to remove the oxygen sensor.

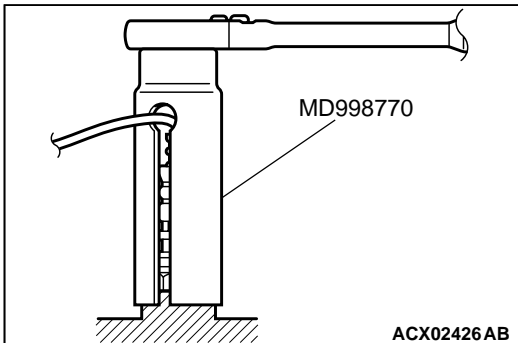

### INSTALLATION SERVICE POINT

>>A<< RIGHT BANK HEATED OXYGEN SENSOR (FRONT)/  
RIGHT BANK HEATED OXYGEN SENSOR (REAR)/LEFT  
BANK HEATED OXYGEN SENSOR (REAR)/HEATED  
OXYGEN SENSOR (REAR) INSTALLATION

Use special tool MD998770 to installation the oxygen sensor.

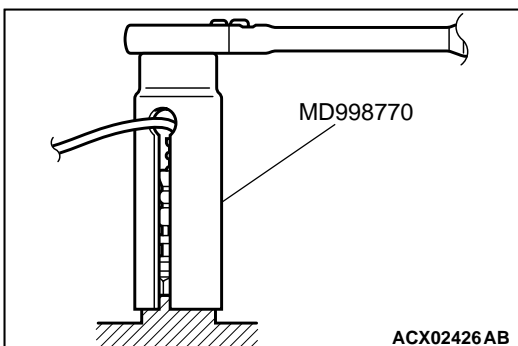

## SPECIFICATIONS

## FASTENER TIGHTENING SPECIFICATIONS

M1173006400078

ITEMS	SPECIFICATIONS
<b>Engine control system</b>	
Accelerator pedal bracket installation	12 ± 2 N·m (100 ± 22 in-lb)
Bracket nut	4.9 ± 1.0 N·m (44 ± 8 in-lb)
<b>Auto-cruise control system</b>	
Auto-cruise control-ECU installation nut	4.9 ± 1.0 N·m (44 ± 8 in-lb)
<b>Emission control system</b>	
EGR valve bolt <2.4L Engine>	19 ± 3 N·m (14 ± 2 ft-lb)
EGR valve bolt <3.0L Engine>	22 ± 4 N·m (16 ± 3 ft-lb)
Exhaust fitting stay(M8) <3.0L Engine>	12 ± 2 N·m (107 ± 17 in-lb)
Exhaust fitting stay(M12) <3.0L Engine>	32 ± 7 N·m (24 ± 5 ft-lb)
Front catalytic converter nut	35 ± 4 N·m (26 ± 3 ft-lb)
Front exhaust pipe nut	49 ± 10 N·m (37 ± 7 ft-lb)
Hanger bolt	12 ± 2 N·m (107 ± 17 in-lb)
Heated oxygen sensor	44 ± 5 N·m (33 ± 3 ft-lb)

## SERVICE SPECIFICATIONS

M1173000300103

ITEMS	STANDARD VALUE
<b>Engine control system</b>	
Accelerator cable free play mm (in)	1 – 2 (0.04 – 0.08)
Curb idle speed r/min <2.4L Engine>	750 ± 100
Curb idle speed r/min <3.0L Engine>	700 ± 100
<b>Emission control system</b>	
EGR solenoid coil resistance [at 20°C (68°F)] Ω	29 – 35
Evaporative emission purge solenoid coil resistance [at 20°C (68°F)] Ω	30 – 34
Evaporative emission ventilation solenoid coil resistance [at 20°C (68°C)] Ω	17 – 21
Purge flow cm <sup>3</sup> /s (SCFH) [at 80 – 95°C (176 – 205°F) with sudden revving]	20 (2.5)