GROUP 00

GENERAL

CONTENTS

GENERAL <BODY AND CHASSIS>	00
GENERAL <ELECTRICAL>	00E

GROUP 00

GENERAL

<BODY AND CHASSIS>

CONTENTS

HOW TO USE THIS MANUAL	00-3	(CHECK FOR LEAKS AND CLOGGING)	00-38
TROUBLESHOOTING GUIDELINES	00-6	SPARK PLUGS (REPLACE)	00-39
HOW TO USE TROUBLESHOOTING/ INSPECTION SERVICE POINTS.	00-6	IGNITION CABLES (REPLACE)	00-39
VEHICLE IDENTIFICATION	00-15	DISTRIBUTOR CAP AND ROTOR (CHECK) <3.0L ENGINE>.	00-40
VEHICLE IDENTIFICATION	00-15	TIMING BELT (REPLACE)	00-40
VEHICLE IDENTIFICATION CODE PLATE	00-17	DRIVE BELT (FOR GENERATOR, WATER PUMP, A/C COMPRESSOR AND POWER STEERING PUMP) (CHECK CONDITION)	00-40
PRECAUTIONS BEFORE SERVICE.	00-21	ENGINE OIL (CHANGE)	00-47
TOWING AND HOISTING	00-23	ENGINE OIL FILTER (REPLACE)	00-48
GENERAL DATA AND SPECIFICATIONS	00-27	MANUAL TRANSMISSION OIL	00-49
TIGHTENING TORQUE	00-30	AUTOMATIC TRANSMISSION FLUID	00-49
LUBRICATION AND MAINTENANCE	00-31	ENGINE COOLANT (CHANGE)	00-52
RECOMMENDED LUBRICANTS AND LUBRICANT CAPACITIES TABLE	00-32	DISC BRAKE PADS (INSPECT FOR WEAR)	00-53
SCHEDULED MAINTENANCE TABLE	00-35	REAR DRUM BRAKE LININGS AND REAR WHEEL CYLINDERS (INSPECT FOR WEAR AND LEAKS).	00-53
MAINTENANCE SERVICE	00-38	BRAKE HOSES (CHECK FOR DETERIORATION OR LEAKS)	00-54
FUEL SYSTEM (TANK, PIPE LINE AND CONNECTION, AND FUEL TANK FILLER TUBE CAP) (CHECK FOR LEAKS)	00-38	BALL JOINT AND STEERING LINKAGE SEALS (INSPECT FOR GREASE LEAKS AND DAMAGE)	00-54
FUEL HOSES (CHECK CONDITION)	00-38	DRIVE SHAFT BOOTS (INSPECT FOR GREASE LEAKS AND DAMAGE).	00-54
AIR CLEANER ELEMENT (REPLACE)	00-38	SRS AIR BAG (INSPECT FOR SRS SYSTEM)	00-55
EVAPORATIVE EMISSION CONTROL SYSTEM (EXCEPT EVAPORATIVE EMISSION CANISTER)		EXHAUST SYSTEM (CONNECTION PORTION OF MUFFLER, PIPINGS AND CONVERTER HEAT SHIELDS) (CHECK AND SERVICE AS REQUIRED)	00-60
		TIRES (ROTATE)	00-60
		AIR PURIFIER FILTER (REPLACE)	00-60
		MAIN SEALANT AND ADHESIVE TABLE	
		00-61

HOW TO USE THIS MANUAL

M1001000100110

MAINTENANCE, REPAIR AND SERVICING EXPLANATIONS

This manual provides explanations, etc. concerning procedures for the inspection, maintenance, repair and servicing of the subject model. Unless otherwise specified, each service procedure covers all models. Procedures covering specific models are identified by the model codes, or similar designation (engine type, transaxle type, etc.). A description of these designations is covered in this manual under "VEHICLE IDENTIFICATION."

ON-VEHICLE SERVICE

"ON-VEHICLE SERVICE" are procedures for performing inspections and adjustments of particularly important locations with regard to the construction and for maintenance and servicing, but other inspections (for looseness, play, cracking, damage, etc.) must also be performed.

SERVICE PROCEDURES

The service steps are arranged in numerical order. Attention must be paid in performing vehicle service are described in detail in SERVICE POINTS.

DEFINITION OF TERMS

STANDARD VALUE

Indicates the value used as the standard for judging the quality of a part or assembly on inspection or the value to which the part or assembly is corrected and adjusted. It is given by tolerance.

LIMIT

Shows the standard for judging the quality of a part or assembly on inspection and means the maximum or minimum value within which the part or assembly must be kept functionally or in strength. It is a value established outside the range of standard value.

REFERENCE VALUE

Indicates the adjustment value prior to starting the work (presented in order to facilitate assembly and adjustment procedures, and so they can be completed in a shorter time).

DANGER, WARNING, AND CAUTION

DANGER, WARNING, and CAUTION call special attention to a necessary action or to an action that must be avoided. The differences among DANGER, WARNING, and CAUTION are as follows:

- If a DANGER is not followed, the result is severe bodily harm or even death.
- If a WARNING is not followed, the result could be bodily injury.
- If a CAUTION is not followed, the result could be damage to the vehicle, vehicle components or service equipment.

TIGHTENING TORQUE INDICATION

The tightening torque indicates a median and its tolerance by a unit of N·m (in-lb) or N·m (ft-lb). For fasteners with no assigned torque value, refer to [P.00-30](#).

SPECIAL TOOL NOTE

Only MMC special tool part numbers are called out in the repair sections of this manual. Please refer to the special tool cross reference chart, which is located in the service manual at the beginning of each group, for a cross reference from the MMC special tool number to the special tool number that is available in your market.

MODEL INDICATIONS

The following abbreviations are used in this manual for classification of model types.

M/T: Indicates manual transaxle, or models equipped with manual transaxle.

A/T: Indicates automatic transaxle, or models equipped with automatic transaxle.

MFI: Indicates multiport fuel injection, or engines equipped with multiport fuel injection.

A/C: Indicates air conditioning.

2.4L Engine: Indicates the 2.4 liter <4G64> engine, or a model equipped with such an engine.

3.0L Engine: Indicates the 3.0 liter <6G72> engine, or a model equipped with such an engine.

PCM: Powertrain control module

ECM: Engine control module

SWS: Simplified Wiring System

EXPLANATION OF MANUAL CONTENTS

Indicates procedures to be performed before the work in that section is started, and procedures to be performed after the work in that section is finished.

Component diagram

A diagram of the component parts is provided near the front of each section in order to give the reader a better understanding of the installed condition of component parts.

Maintenance and servicing procedures

The numbers provided within the diagram indicate the sequence for maintenance and servicing procedures.

- Removal steps :

The part designation number corresponds to the number in the illustration to indicate removal steps.

- Disassembly steps :

The part designation number corresponds to the number in the illustration to indicate disassembly steps.

- Installation steps :

Specified in case installation is impossible in reverse order of removal steps. omitted if installation is possible in reverse order of removal steps.

- Assembly steps :

Specified in case assembly is impossible in reverse order of disassembly steps. Omitted if assembly is possible in reverse order of disassembly steps.

Classifications of major maintenance / service points

When there are major points relative to maintenance and servicing procedures (Such as essential maintenance and service points, maintenance and service standard values, information regarding the use of special tools, etc.), These are arranged together as major maintenance and service points and explained in detail.

<<A>>: Indicates that there are essential points for removal or disassembly.

>>A<<: Indicates that there are essential points for installation or assembly.

Symbols for lubrication, sealants and adhesives

Information concerning the locations for lubrication and for application of sealants and adhesives is provided, by using symbols, in the diagram of component parts or on the page following the component parts page, and explained.



: Grease
(Multipurpose grease unless there is a brand or type specified)



: Sealant or adhesive



: Brake fluid or automatic transmission fluid



: Engine oil, gear oil or air conditioning compressor oil



: Adhesive tape or butyl rubber tape

Indicates the group title. Indicates the section title. Indicates the group number. Indicates the page number.

BASIC BRAKE SYSTEM
FRONT DISC BRAKE ASSEMBLY 35A-81

FRONT DISC BRAKE ASSEMBLY

REMOVAL AND INSTALLATION

Pre-removal Operation	Post-installation Operation
• Brake Fluid Draining	• Brake Fluid Supplying and Air Bleeding (Refer to .)

Mark **N** denotes non-reusable part.

Denotes tightening torque. If there is no indication of tightening torque, refer to tightening torque .

BRAKE CALIPER KIT	PAD SET	SHIM KIT	SEAL AND BOOT KIT

REMOVAL STEPS

1. BRAKE HOSE CONNECTION
2. GASKET

REMOVAL STEPS (continued)

3. DISC BRAKE ASSEMBLY
4. BRAKE DISC

Required Special Tool:

- MB990520: Disc Brake Piston Expander

INSTALLATION SERVICE POINT

>>A<< DISC BRAKE ASSEMBLY INSTALLATION

1. To check the brake drag force after mounting the pad, measure the hub torque in the advancing direction using a spring balance with the pad is removed.

CAUTION

Do not allow any oil, grease or other contamination to contact the friction surfaces of the pads and brake discs.

2. After re-installing the caliper support to the knuckle, install the pad clips and the pads to the caliper support.

Operating procedures, cautions, etc. On removal, installation, disassembly and assembly are described.

LUBRICATION AND SEALING POINTS

The title of the page (following the page on which the diagram of component parts is presented) indicating the locations of lubrication and sealing procedures.

Indicates (by symbols) where lubrication is necessary.

ACX00860AC

TROUBLESHOOTING GUIDELINES

M1001008800102

VERIFY THE COMPLAINT

- Make sure the customer's complaint and the service writer's work order description are understood before starting work.
- Make sure the correct operation of the system is understood. Read the service manual description to verify any aspect of normal system operation.
- Operate the system to see the symptoms. Look for other symptoms that were not reported by the customer, or on the work order, that may be related to the problem.

DETERMINE POSSIBLE CAUSES

Compare the confirmed symptoms to the diagnostic symptom indexes to get to the right diagnosis procedure.

If the confirmed symptoms can not be found on any symptom index, determine other possible causes.

- Analyze the system diagrams and list all possible causes for the problem symptoms.
- Rank all these possible causes in order of probability, based on how much of the system they cover, how likely they are to be the cause, and how easy they will be to check. Be sure to take experience into account. Consider the causes of similar problems seen in the past. The list of causes should be ranked in order from general to specific, from most-likely to least-likely, and from easy-to-check to hard-to-check.

FIND THE PROBLEM

After the symptoms have been confirmed, and probable causes have been identified, the next step is to make step-by-step checks of the suspected system components, junctions, and links in logical order.

Use the diagnostic procedures in the service manual whenever possible. Follow these procedures carefully to avoid missing an important step in the diagnosis sequence. It might be the skipped step that leads to the solution of the problem.

If the service manual doesn't have step-by-step procedures to help diagnose the problem, come up with a series of checks based on the ranked list of probable causes. Troubleshooting checks should be made in the order that the list of causes was ranked:

- general to specific
- most-likely to least-likely
- easy-to-check to hard-to-check

REPAIR THE PROBLEM

When the step-by-step troubleshooting checks find a fault, perform the proper repairs. Make sure to fix the root cause of the problem, not just the symptom. Just fixing the symptom, without fixing the root cause, will cause the symptom to eventually return.

VERIFY THE REPAIR

After repairs are made, recheck the operation of the system to confirm that the problem is eliminated.

Make sure to check the system thoroughly.

Sometimes new problems are revealed after repairs have been made.

HOW TO USE TROUBLESHOOTING/INSPECTION SERVICE POINTS

Troubleshooting of electronic control systems for which the scan tool can be used follows the basic outline described below. Even in systems for which the scan tool cannot be used, part of these systems still follow this outline.

TROUBLESHOOTING CONTENTS

1. STANDARD FLOW OF DIAGNOSTIC TROUBLESHOOTING

Troubleshooting strategy are shown.

2. SYSTEM OPERATION AND SYMPTOM VERIFICATION TESTS

If verification of the symptoms is difficult, procedures for checking operation and verifying symptoms are shown.

3. DIAGNOSTIC FUNCTION

The following trouble code diagnosis are shown.

- How to read diagnostic trouble codes
- How to erase diagnostic trouble codes
- Input inspection service points

M1001000200098

4. DIAGNOSTIC TROUBLE CODE CHART

5. SYMPTOM CHART

If there are symptoms, even though the results of inspection using the scan tool show that all diagnostic trouble codes are normal, inspection procedures for each symptom will be found by using this chart.

6. DIAGNOSTIC TROUBLE CODE PROCEDURES

Indicates the inspection procedures corresponding to each diagnostic trouble code. (Refer to P.00-7.)

7. SYMPTOM PROCEDURES

Indicates the inspection procedures corresponding to each symptoms classified in the Symptom Chart. (Refer to P.00-7.)

8. SERVICE DATA REFERENCE TABLE

Inspection items and normal judgement values have been provided in this chart as reference information.

9. CHECK AT ECU TERMINALS

Terminal numbers for the ECU connectors, inspection items and standard values have been provided in this chart as reference information.

Terminal Voltage Checks

1. Connect a needle-nosed wire probe to a voltmeter probe.

CAUTION

Short-circuiting the positive (+) probe between a connector terminal and ground could damage the vehicle wiring, the sensor, the ECU, or all three. Use care to prevent this!

2. Insert the needle-nosed wire probe into each of the ECU connector terminals from the wire side, and measure the voltage while referring to the check chart.

NOTE: Measure voltage with the ECU connectors connected.

You may find it convenient to pull out the ECU to make it easier to reach the connector terminals.

Checks don't have to be carried out in the order given in the chart.

3. If voltage readings differ from normal condition values, check related sensors, actuators, and wiring, then replace or repair.
4. After repair or replacement, recheck with the voltmeter to confirm that the repair has corrected the problem.

Terminal Resistance and Continuity Checks

1. Turn the ignition switch to "LOCK" (OFF) position.
2. Disconnect the ECU connector.

CAUTION

If resistance and continuity checks are performed on the wrong terminals, damage to the vehicle wiring, sensors, ECU, and/or ohmmeter may occur. Use care to prevent this!

3. Measure the resistance and check for continuity between the terminals of the ECU harness-side connector while referring to the check chart.

NOTE: Checks don't have to be carried out in the order given in the chart.

4. If the ohmmeter shows any deviation from the Normal Condition value, check the corresponding sensor, actuator and related electrical wiring, then repair or replace.
5. After repair or replacement, recheck with the ohmmeter to confirm that the repair has corrected the problem.

10. INSPECTION PROCEDURES USING AN OSCILLOSCOPE

When there are inspection procedures using an oscilloscope, these are listed here.

HOW TO USE THE INSPECTION PROCEDURES

The causes of many of problems occurring in electric circuitry are generally the connectors, components, the ECU and the harnesses between connectors, in that order. These inspection procedures follow this order. They first try to discover a problem with a connector or a defective component.

DTC P0110: Intake Air Temperature Circuit Malfunction

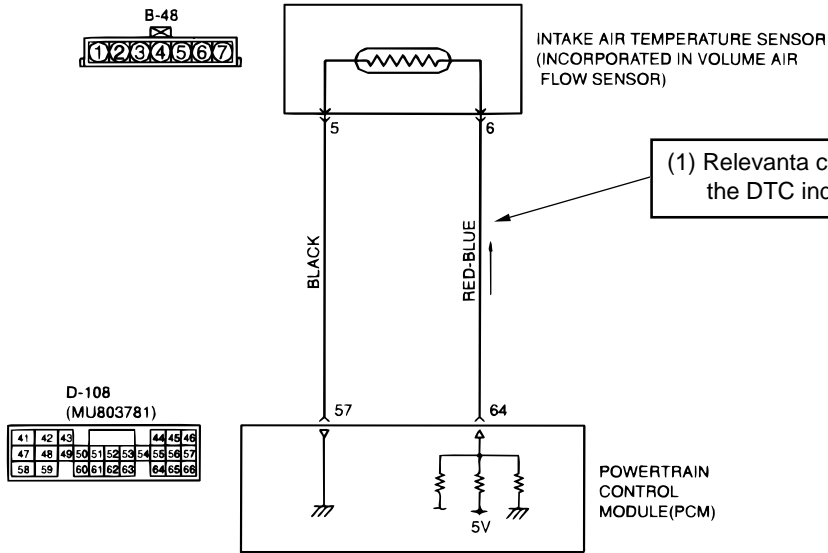

(1) Relevanta circuit(s) of the component which the DTC indicates are described.

(2) Shows the position of the connector(s) which are referred to in the above circuit(s).

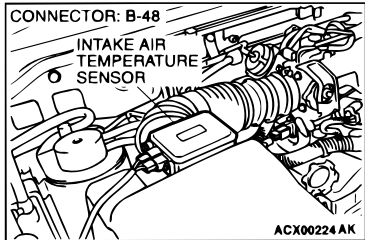

(3) Explains about the operation principle of the component or its relevant parts in that circuit.

CIRCUIT OPERATION

- Approximately 5 volts are applied to the intake air temperature sensor output terminal (terminal 6) from the PCM (terminal 64) via the resistor in the PCM. The ground terminal (terminal 5) is grounded with or PCM (terminal 57).
- The intake air temperature sensor is a negative temperature coefficient type of resistor. When the intake air temperature rises, the resistance decreases.
- The intake air temperature sensor output voltage increases when the resistance increases and decreases when the resistance decreases.

ACX00861AC

(4) Explains about technical details.

TECHNICAL DESCRIPTION

- The intake air temperature sensor converts the intake air temperature to a voltage
- The PCM checks whether this voltage is within a specified range.

DTC SET CONDITIONS

Check Conditions

- Two seconds or more have passed since the engine was started.

Judgement Criteria

- Intake air temperature sensor output voltage has continued to be 4.6 volts or higher [corresponding to an air intake temperature of -45°C (-49°F) or lower] for 2 seconds.

(5) Describes the conditions for that DTC being set (stored).

- Intake air temperature sensor output voltage has continued to be 0.2 volt or lower [corresponding to an air intake temperature of 125°C (257°F) or higher] for 2 seconds.

TROUBLESHOOTING HINTS(The most likely causes for this code to be set are:)

- Intake air temperature sensor failed.
- Open or shorted intake air temperature sensor circuit, or loose connector.
- PCM failed.

(6) Describes possible cause(s) for that DTC.

(7) Describes the diagnosis procedure for that DTC.

(8) Describes the special tool(s) necessary for that DTC.

DIAGNOSIS

Required Special Tool:
MB991502: Scan Tool(MUT-II)

STEP 1. Using scan tool MB991502, check data list item 13: Intake Air Temperature Sensor.

CAUTION
To prevent damage to scan tool MB991502, always turn the ignition switch to "LOCK"(OFF) position before connecting or disconnecting scan tool MB991502.

- Connect scan tool MB991502 to the data link connector.
- Turn the ignition switch to "ON" position.
- Set scan tool MB991502 to the data reading mode for item 13, Intake Air Temperature Sensor.
 - The intake air temperature and temperature shown with the scan tool should approximately match.
- Turn the ignition switch to "LOCK"(OFF) position.

Q: Is the sensor operating properly?

YES : It can be assumed that this malfunction is intermittent. Refer to GROUP 00, How to Use Troubleshooting/ Inspection Service Points.

NO : Go to Step 2.

(9) Describes the inspection procedure for that DTC step by step.

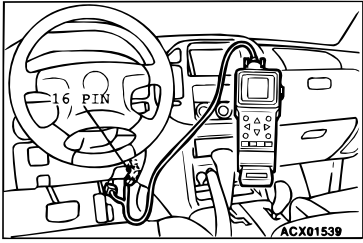

ACX00862 AC

HARNES INSPECTION

Check for an open or short circuit in the harness between the terminals which were faulty according to the connector measurements. Carry out this inspection while referring to GROUP 00E, Harness Connector Inspection P.00E-2. Here, "Check

harness between power supply and terminal xx" also includes checking for blown fuse. For inspection service points when there is a blown fuse, refer to "Inspection Service Points for a Blown Fuse P.00-15."

MEASURES TO TAKE AFTER REPLACING THE ECU

If the trouble symptoms have not disappeared even after replacing the ECU, repeat the inspection procedure from the beginning.

CONNECTOR MEASUREMENT SERVICE POINTS

Turn the ignition switch to the "LOCK" (OFF) position when connecting and disconnecting the connectors. Turn the ignition switch to "ON" when measuring if there are no instructions to the contrary.

IF INSPECTING WITH THE CONNECTOR CONNECTED (WITH CIRCUIT IN A CONDITION OF CONTINUITY)**Required Special Tool:**

MD998459: Test Harness

Waterproof Connectors

Be sure to use special tool, MB998459. Never insert a test probe from the harness side, as this so will reduce the waterproof performance and result in corrosion.

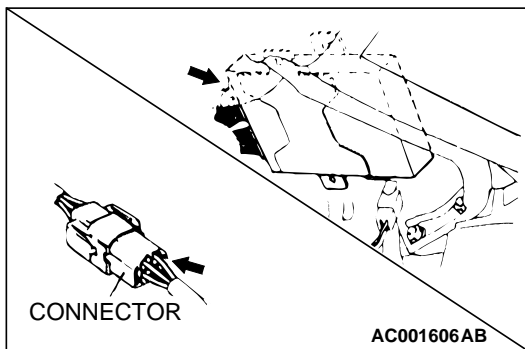
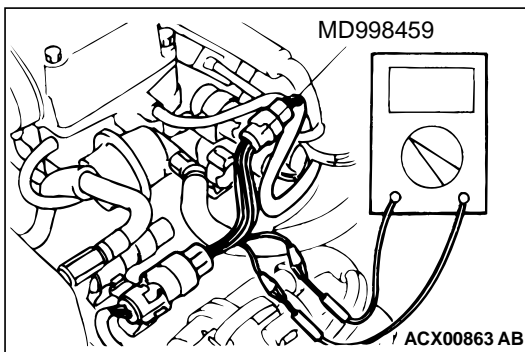
**Ordinary (non-waterproof) Connectors**

Check by inserting the test probe from the harness side. Note that if the connector (control unit, etc.) is too small to permit insertion of the test probe, it should not be forced; use the backprobing tool for this purpose.

IF INSPECTING WITH THE CONNECTOR DISCONNECTED**<When Inspecting a Female Pin>**

- From front side of the connector

Required Special Tool:

MB991219:

Inspection Harness (Included in MB991223, Harness Set)

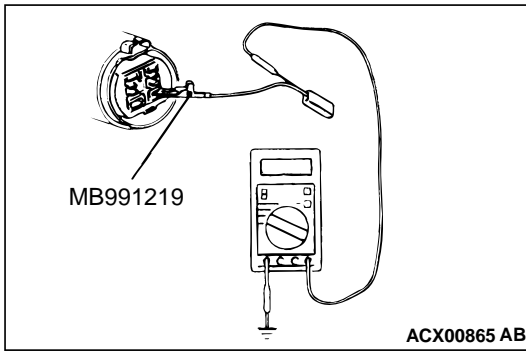

- The inspection harness for connector pin contact pressure should be used. The test probe should never be forcibly inserted, as it may cause a defective contact.
- From back side of the connector (SRS-ECU harness side connector)

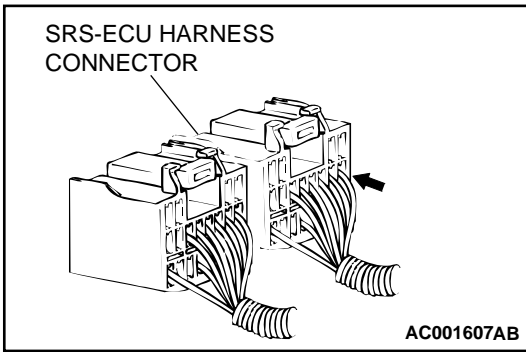

Since the SRS-ECU harness connector is plated to improve conductivity, observe the warning below when checking this connector.

⚠ WARNING

Insert the backprobing tool into connector from harness side, and connect the tester to the backprobing tool. If any tool other than the backprobing tool is used, it may cause damage to the harness and other components. Furthermore, measurement should not be carried out by touching the backprobing tool directly against the terminals from the front of the connector. The terminals are plated to increase their conductivity, so that if they are touched directly by the backprobing tool, the plating may break, which will decrease reliability.

<When Inspecting a Male Pin>

⚠ CAUTION

At this time, be careful not to short the connector pins with the test probes. To do so may damage the circuits inside the ECU.

Touch the pin directly with the test bar.

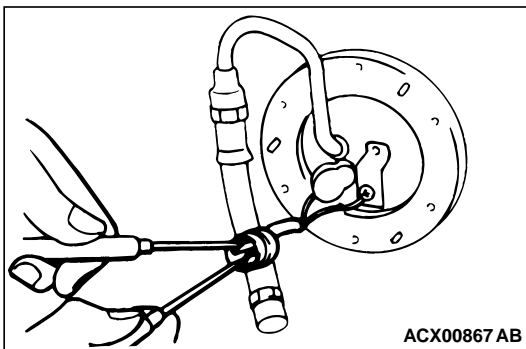

CONNECTOR INSPECTION SERVICE POINTS**VISUAL INSPECTION**

- Connector is disconnected or improperly connected
- Connector pins are pulled out
- Due to harness tension at terminal section
- Low contact pressure between male and female terminals
- Low connection pressure due to rusted terminals or foreign matter lodged in terminals

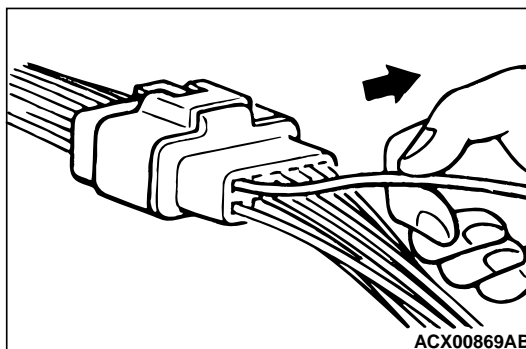
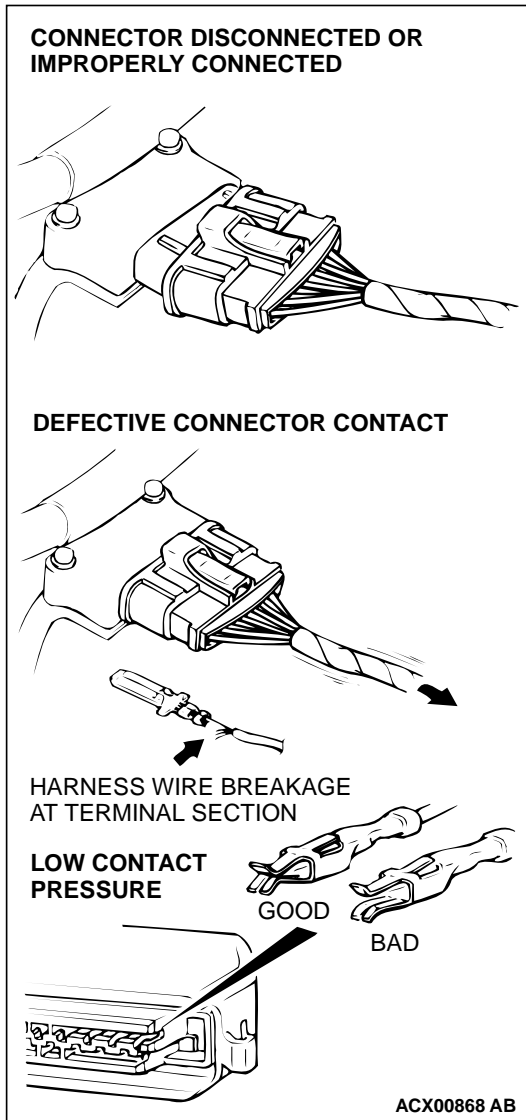
**CONNECTOR PIN INSPECTION**

If the connector pin stopper is damaged, the terminal connections (male and female pins) will not be perfect even when the connector body is connected, because the pins may pull out of the back side of the connector. Therefore, gently pull the wires one by one to make sure that no pins pull out of the connector.

CONNECTOR ENGAGEMENT INSPECTION

Required Special Tool:

MB991219: Inspection Harness (contained in MB991223 Test Harness)

Use special tool, MB991219 to inspect the engagement of the male pins and female pins. [Pin drawing force: 1 N (0.2 pound) or more]

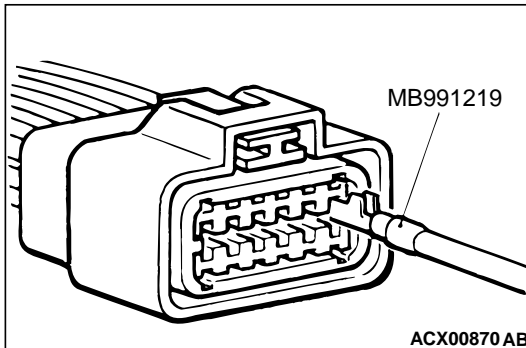

HOW TO COPE WITH INTERMITTENT MALFUNCTIONS

Most intermittent malfunctions occur under certain conditions. If those conditions can be identified, the cause will be easier to find.

TO COPE WITH INTERMITTENT MALFUNCTION;

1. Ask the customer about the malfunction

Ask what it feels like, what it sounds like, etc. Then ask about driving conditions, weather, frequency of occurrence, and so on.

2. Determine the conditions from the customer's responses

Typically, almost all intermittent malfunctions occur from conditions like vibration, temperature and/or moisture change, poor connections. From the customer's responses, it should be reasoned which condition is influenced.

3. Use simulation test

In the cases of vibration or poor connections, use the simulation tests below to attempt to duplicate the customer's complaint. Determine the most likely circuit(s) and perform the simulation tests on the connectors and parts of that circuit(s). Be sure to use the inspection procedures provided for diagnostic trouble codes and trouble symptoms.

For temperature and/or moisture conditions related intermittent malfunctions try to change the conditions of the suspected circuit components, then use the simulation tests below.

4. Verify the intermittent malfunction is eliminated

Repair the malfunctioning part and try to duplicate the condition(s) again to verify the intermittent malfunction has been eliminated.

SIMULATION TESTS

NOTE: In case of difficulty in finding the cause of the intermittent malfunction, the data recorder function in the scan tool is effective.

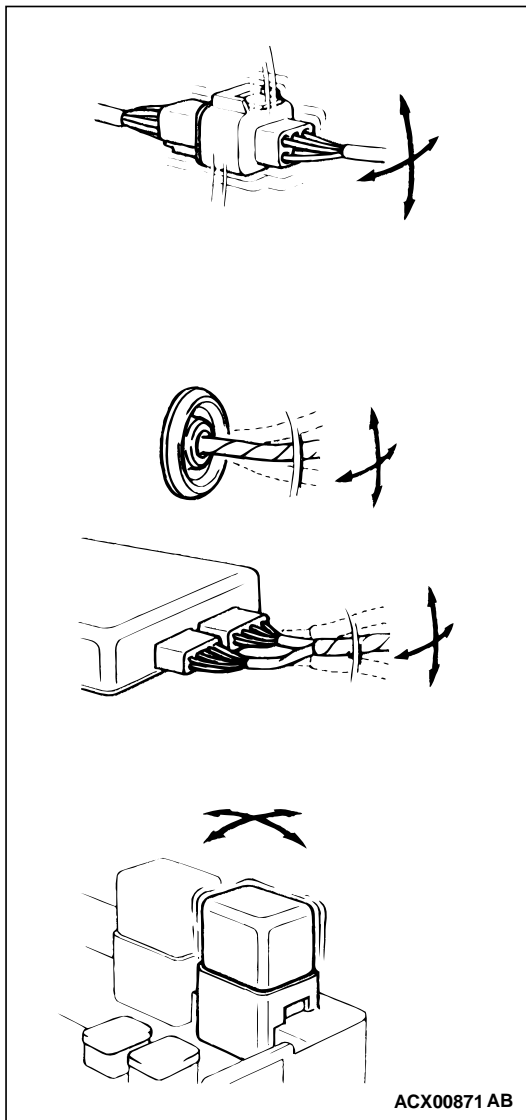

For these simulation tests, shake, then gently bend, pull, and twist the wiring of each of these examples to duplicate the intermittent malfunction.

- Shake the connector up-and-down, and right-and-left.
- Shake the wiring harness up-and-down, and right-and-left.
- Vibrate the part or sensor.

INSPECTION SERVICE POINTS FOR A BLOWN FUSE

Remove the fuse and measure the resistance between the load side of the fuse and ground. Set the switches of all circuits which are connected to this fuse to a condition of continuity. If the resistance is almost 0Ω at this time, there is a short somewhere between these switches and the load. If the resistance is not 0Ω , there is no short at the present time, but a momentary short has probably caused the fuse to blow.

The main causes of a short circuit are the following.

- Harness being clamped by the vehicle body
- Damage to the outer casing of the harness due to wear or heat
- Water getting into the connector or circuitry
- Human error (mistakenly shorting a circuit, etc.)

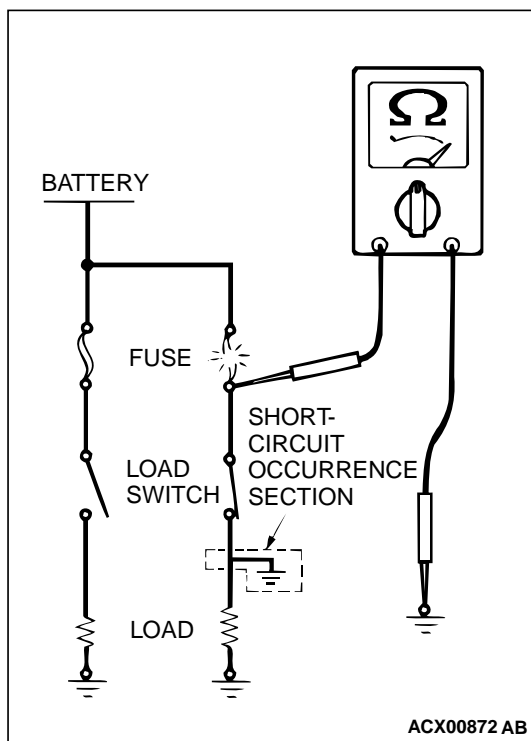

VEHICLE IDENTIFICATION

VEHICLE IDENTIFICATION

M1001000400122

VEHICLES IDENTIFICATION NUMBER LOCATION

The vehicle identification number (VIN) is located on a plate attached to the left top side of the instrument panel.

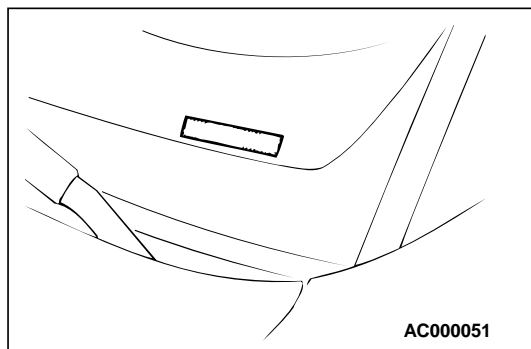

VEHICLE IDENTIFICATION CODE CHART PLATE

All vehicle identification numbers contain 17 digits. The vehicle number is a code which tells country, make, vehicle type, etc.

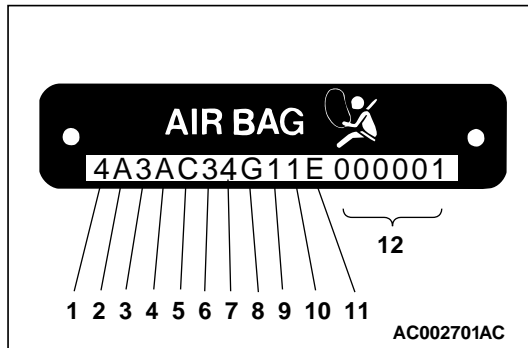

NO.	ITEMS	CONTENTS
1	Country	4: USA
2	Make	A: Mitsubishi
3	Vehicle type	3: Passenger car
4	Others	A: Driver and passenger air bags
5	Line	C: ECLIPSE E: ECLIPSE SPYDER
6	Price class	3: Medium 4: High 5: Premium 8: Sports
7	Body	4: 3-door hatch back 5: 2-door convertible
8	Engine	G: 2.4L H: 3.0L
9	Check digits*	0, 1, 2, 3, -----9, X
10	Model year	1: 2001 year
11	Plant	E: Mitsubishi Motor Manufacturing of America, Inc.
12	Serial number	000001 to 999999

*NOTE: *: Check digit means a singles number or letter X used to verify the accuracy of transcription of vehicle identification number.*

VEHICLE IDENTIFICATION NUMBER LIST

ECLIPSE

VIN (EXCEPT SEQUENCE NUMBER)	BRAND	ENGINE DISPLACEMENT	MODEL CODE
4A3AC34G_1E	MITSUBISHI ECLIPSE	2.4L	D52AMNJEL4M
4A3AC44G_1E			D52AMRJEL4M
			D52AMNHEL4M
4A3AC84H_1E			D52AMRHEL4M
		3.0L	D53AMNXEL4M
D53AMRXEL4M			
D53AMNGEL4M			
4A3AC54H_1E			D53AMRGEL4M

ECLIPSE SPYDER

VIN (EXCEPT SEQUENCE NUMBER)	BRAND	ENGINE DISPLACEMENT	MODEL CODE
4A3AE45G_1E	MITSUBISHI ECLIPSE SPYDER	2.4L	D52ABNHEL4M
			D52ABRHEL4M
4A3AE85H_1E		3.0L	D53ABNXEL4M
			D53ABRXEL4M

VEHICLE IDENTIFICATION CODE PLATE

M1001005400105

The vehicle information code plate is riveted onto the cowl top outer panel in the engine compartment.

The plate shows model code, engine model, transmission model and body color code.

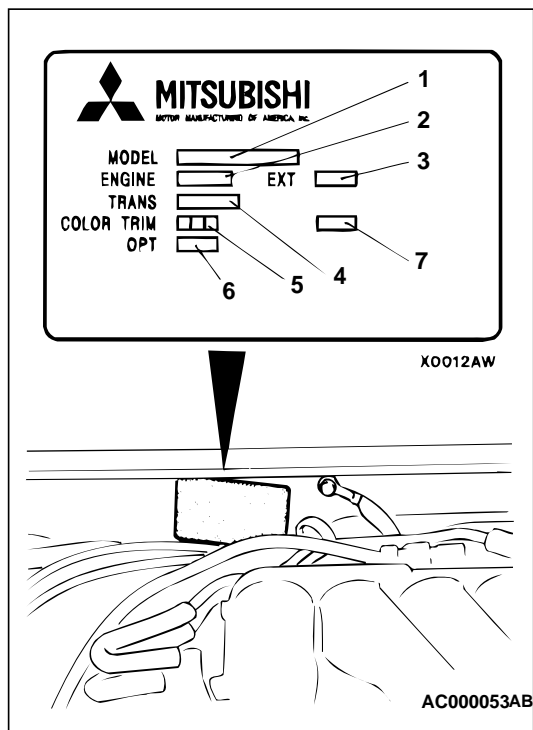

NO.	ITEMS	CONTENTS	
1	MODEL	D53AMRG EL4M	D53A: Vehicle model
			MRGEL4M; Model series
2	ENGINE	6G72	Engine model
3	EXT	W69A	Exterior code
4	TRANS	F4A51	F4A51:Transaxle model
5	COLOR	W69	W69: Body color code
6	TRIM	71H	71H: Interior code
7	OPT	Z31	Z31: Equipment code

For monotone color vehicles, the body color code shall be indicated.

VEHICLE SAFETY CERTIFICATION LABEL

The vehicle safety certification label is attached to the face of the left door sill.

This label indicates the month and year of manufacture, Gross Vehicle Weight Rating (GVWR), front and rear Gross Axle Weight Rating (GAWR), and Vehicle Identification Number (VIN).

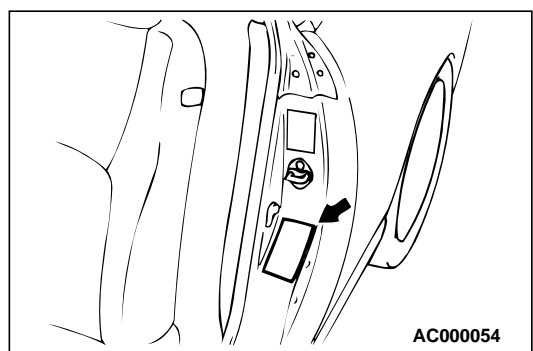

ENGINE MODEL STAMPING

The engine model is stamped on the cylinder block. These engine model numbers are as shown as follows.

ENGINE MODEL	ENGINE DISPLACEMENT
4G64	2.4L
6G72	3.0L

The engine serial number is stamped near the engine model number.

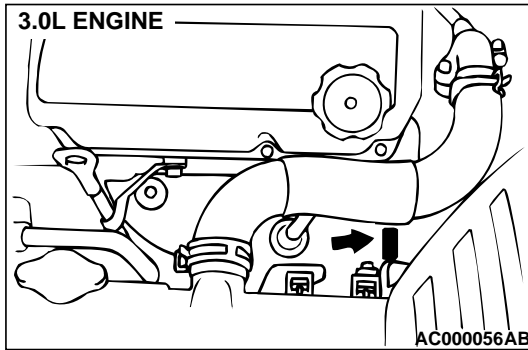
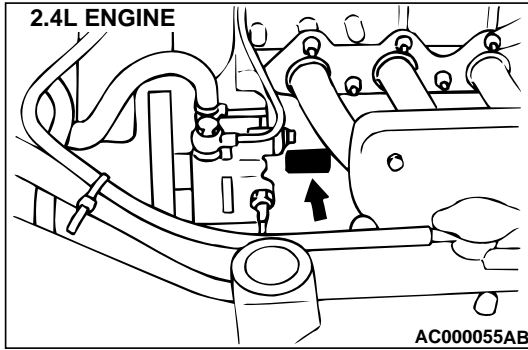

THEFT PROTECTION

In order to protect against theft, a Vehicle Identification Number (VIN) is attached as a plate or label to the following major parts of the engine and transmission, as well as main outer panels: Engine cylinder block, Transmission housing, Fender, Doors, Liftgate, Quarter panel, Hood, Bumpers.

In addition, a theft-protection label is attached to replacement parts for the body outer panel main components, and the same data are stamped into replacement parts for the engine and the transmission.

CAUTION

Cautions regarding panel repairs:

1. When repainting original parts, do so after first masking the theft-protection label. After painting, be sure to peel off the masking tape.
2. The theft-protection label for replacement parts is covered by masking tape, so such parts can be painted as is. The masking tape should be removed after painting is finished.
3. The theft-protection label should not be removed from original parts or replacement parts.

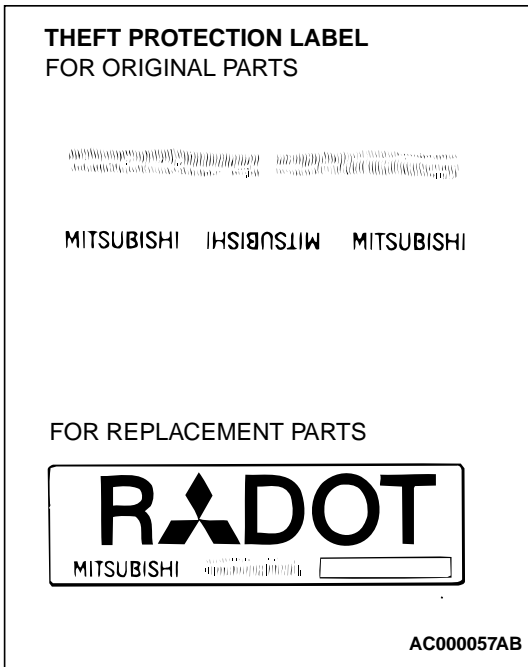

LOCATIONS

TARGET AREA (A: FOR ORIGINAL EQUIPMENT PARTS, B: FOR REPLACEMENT PARTS)

ENGINE
<4G64>

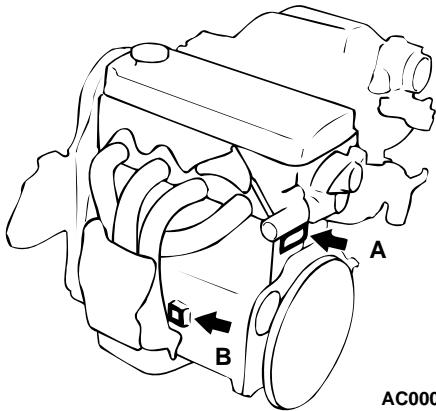

AC000058AB

ENGINE
<6G72>

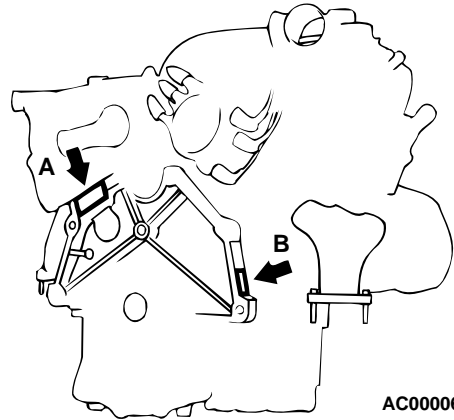

AC000061AB

MANUAL TRANSAXLE
<F5M42>

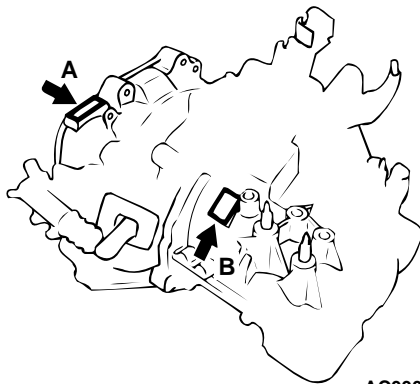

AC000059AB

MANUAL TRANSAXLE
<F5M51>

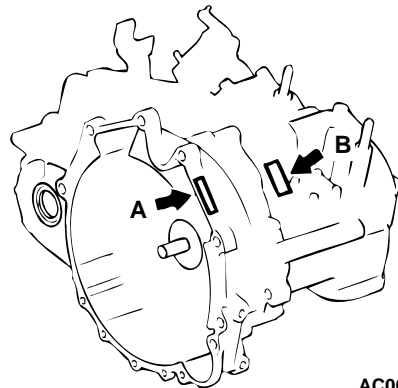

AC000062AB

AUTOMATIC TRANSAXLE

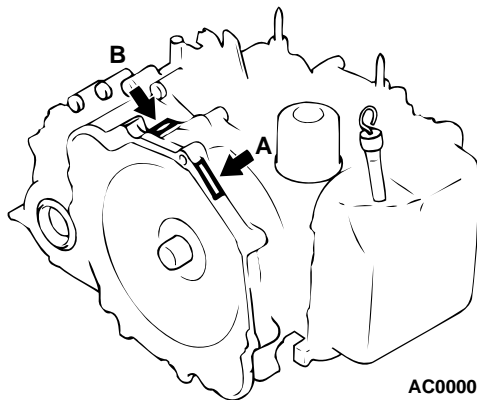

AC000060AB

FENDER

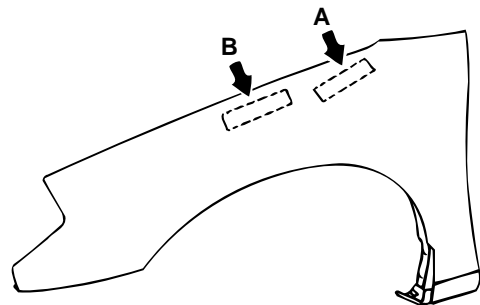

THE ILLUSTRATION INDICATOR LEFT OVER SIDE. RIGHT SIDE IS SYMMETRICALLY OPPOSITE.

AC000063AB

TARGET AREA (A: FOR ORIGINAL EQUIPMENT PARTS, B: FOR REPLACEMENT PARTS)

QUARTER PANEL OUTER

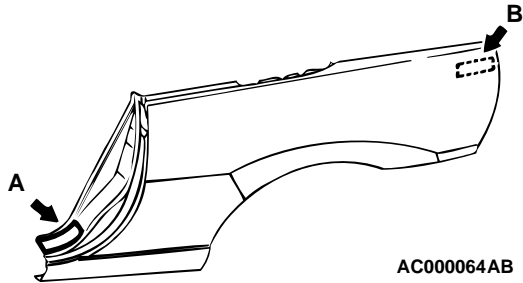

AC000064AB

THE ILLUSTRATION INDICATOR LEFT OUER SIDE. RIGHT SIDE IS SYMMETRICALLY OPPOSITE.

DOOR

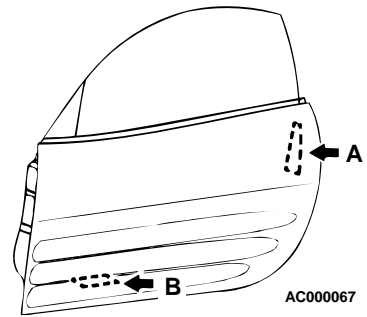

AC000067

THE ILLUSTRATION INDICATOR LEFT OUER SIDE. RIGHT SIDE IS SYMMETRICALLY OPPOSITE.

HOOD

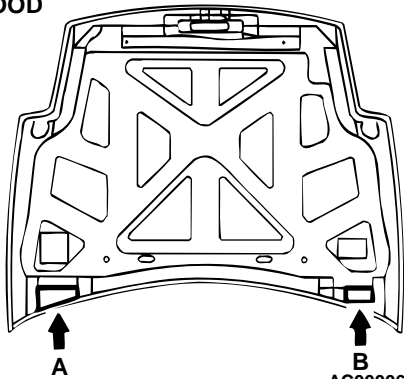

AC000065AB

LIFTGATE <ECLIPSE>

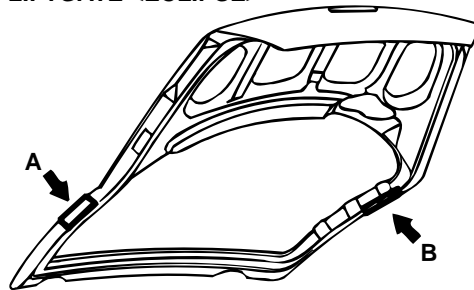

AC000068AB

TRUNK LID <ECLIPSE SPYDER>

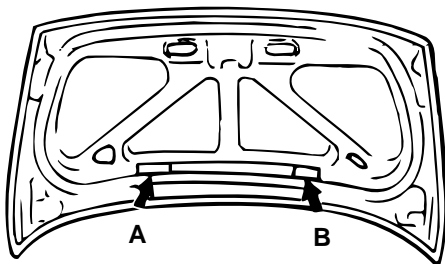

AC004278AB

FRONT BUMPER

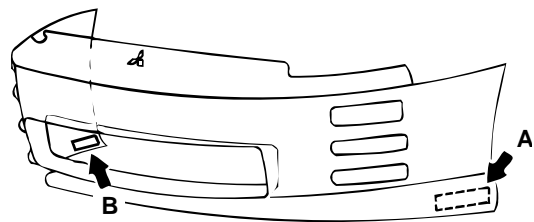

AC000066Af

TARGET AREA (A: FOR ORIGINAL EQUIPMENT PARTS, B: FOR REPLACEMENT PARTS)

REAR BUMPER

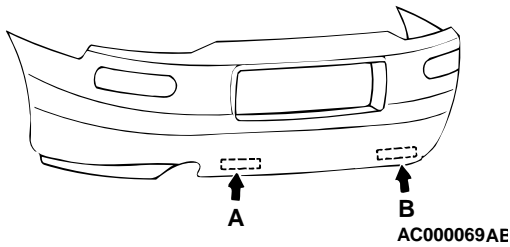

PRECAUTIONS BEFORE SERVICE

M1001000500088

SUPPLEMENTAL RESTRAINT SYSTEM (SRS)

1. Items to follow when servicing SRS

- (1) Be sure to read GROUP 52B, Supplemental Restraint System (SRS). For safe operation, please follow the directions and heed all warnings.
- (2) Wait at least 60 seconds after disconnecting the battery cable before doing any further work. The SRS system is designed to retain enough voltage to deploy the air bag even after the battery has been disconnected. Serious injury may result from unintended air bag deployment if work is done on the SRS system immediately after the battery cable is disconnected.
- (3) Warning labels must be heeded when servicing or handling SRS components. Warning labels can be found in the following locations.
 - Hood
 - Sun visor
 - Glove box
 - SRS-ECU
 - Steering wheel
 - Air bag module (Driver's side or front passenger's side)
 - Side air bag module
 - Clock spring
 - Steering gear box

- (4) Always use the designated special tools and test equipment.
- (5) Store components removed from the SRS in a clean and dry place. The air bag module should be stored on a flat surface and placed so that the pad surface is facing upward.
- (6) Never attempt to disassemble or repair the SRS components (SRS-ECU, air bag module and clock spring). If there is a defect, replace the defective part.
- (7) Whenever you finish servicing the SRS, check the SRS warning light operation to make sure that the system functions properly.
- (8) Be sure to deploy the air bag before disposing of the air bag module or disposing of a vehicle equipped with an air bag. (Refer to GROUP 52B P.52B-80, Air Bag Module Disposal Procedures.)

2. Observe the following when carrying out operations on places where SRS components are installed, including operations not directly related to the SRS air bag.

- (1) When removing or installing parts, do not allow any impact or shock to the SRS components.
- (2) SRS components should not be subjected to temperatures of over 93°C (200°F), so remove the SRS components before drying or baking the vehicle after painting. After re-installing them, check the SRS warning light operation to make sure that the system functions properly.

SERVICING ELECTRICAL SYSTEM**⚠ WARNING**

Battery posts, terminals and related accessories contain lead and lead compounds. WASH HANDS AFTER HANDLING.

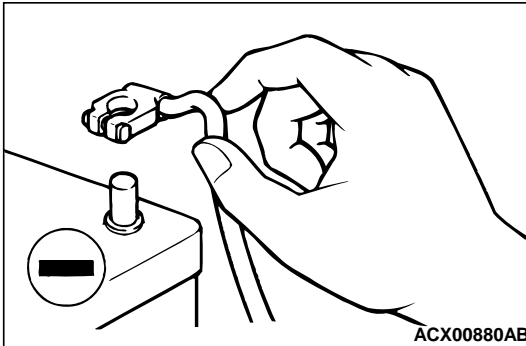

- Note the following before proceeding with working on the electrical system.
Never perform unauthorized modifications to any electrical device or wiring. Such modifications might lead to a vehicle malfunction, over-capacity or short-circuit that could result in a fire in the vehicle.

⚠ CAUTION

- Before connecting or disconnecting the negative battery cable, be sure to turn off the ignition switch and the lights. (If this is not done, there is the possibility of semiconductor parts being damaged.)
 - After completion of the work steps (when the negative battery terminal is connected), warm up the engine and allow it to idle for approximately 10 minutes under the conditions described below in order to stabilize engine control conditions, and then check to be sure that the idling is satisfactory.
- When servicing the electrical system, disconnect the negative cable terminal from the battery.
Engine coolant temperature: 85 – 95°C (185 – 203°F)
Lights and all accessories: OFF
Transmission: "N" or "P" position
Steering wheel: straight-forward position

VEHICLE WASHING

If high-pressure car-washing equipment or steam car-washing equipment is used to wash the vehicle, be sure to maintain the spray nozzle at a distance of at least approximately 40cm (16 inches) from any plastic parts and all opening parts (doors, luggage compartment, etc.).

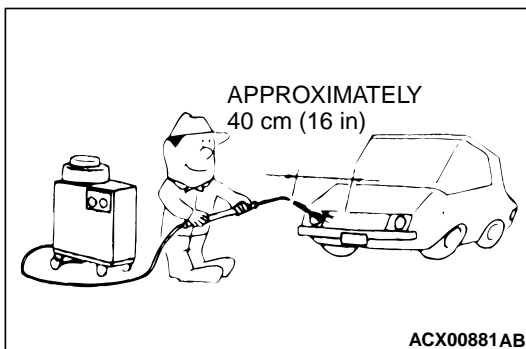
**APPLYING ANTI-CORROSION AGENT OR OTHER UNDERCOAT AGENTS**

Be careful not to adhere oil or grease to the heated oxygen sensor. If adhered, the sensor may malfunction. Protect the heated oxygen sensor with a cover before applying anti-corrosion agent, etc.

SCAN TOOL (MUT-II)

⚠ CAUTION

Turn the ignition switch to "LOCK" (OFF) position before disconnecting or connecting the scan tool.

To operate the scan tool, refer to "MUT-II Operating Instructions."

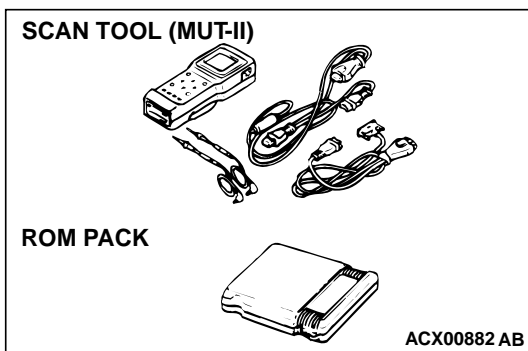

TOWING AND HOISTING

M1001000800090

WRECKER TOWING RECOMMENDATION

FRONT TOWING PICKUP

⚠ CAUTION

This vehicle cannot be towed by a wrecker using sling-type equipment to prevent the bumper from deformation. If this vehicle is towed, use wheel lift or flat bed equipment.

The vehicle may be towed on its rear wheels for extended distances provided the parking brake is released. It is recommended that vehicles be towed using the front pickup whenever possible.

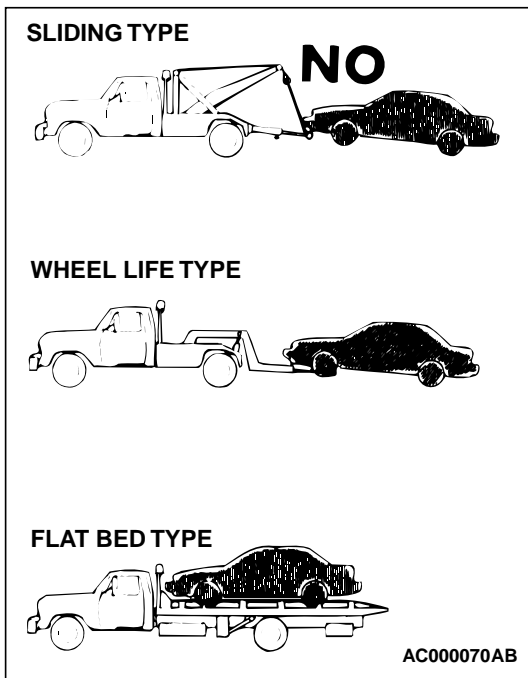

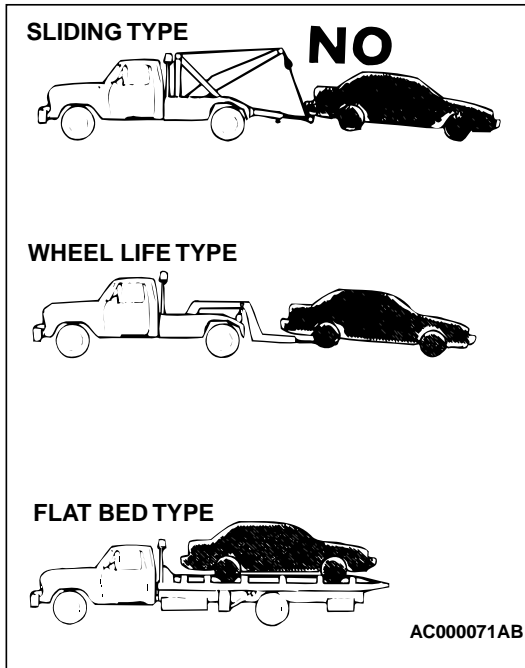
**REAR TOWING PICKUP****⚠ CAUTION**

- This vehicle cannot be towed by a wrecker using sling-type equipment to prevent the lower arm from deformation. If this vehicle is towed, use a wheel lift or flat bed equipment.
- Do not use the steering column lock to secure the front wheel for towing.
- Make sure the transaxle is in Neutral if vehicle will have drive wheels on the ground.
- If these limits cannot be met, the front wheels must be placed on a tow dolly.

Automatic transmission vehicle may be towed on the front wheels at speeds not to exceed 50 km/h (30 mph) for distances not to exceed 30 km (18 miles).

TOWING WHEN KEYS ARE NOT AVAILABLE

When a locked vehicle must be towed and keys are not available, the vehicle may be lifted and towed from the front, provided the parking brake is released. If not released, the rear wheels should be placed on a tow dolly.

SAFETY PRECAUTIONS

The following precautions should be taken when towing the vehicle:

1. DO NOT LIFT OR TOW THE VEHICLE BY ATTACHING TO OR WRAPPING AROUND THE BUMPER.
2. Any loose or protruding parts or damaged vehicle such as hoods, doors, fenders, trim, etc. should be secured or removed prior to moving the vehicle.
3. Operator should refrain from going under a vehicle it is lifted by the towing equipment, unless the vehicle is adequately supported by safety stands.
4. Never allow passengers to ride in a towed vehicle.
5. State and local rules and regulations must be followed when towing a vehicle.

LIFTING, JACKING SUPPORT LOCATION

FLOOR JACK

⚠ CAUTION

- Never support any point other than the specified one, or it will be deformed.
- For lifting, put rubber or similar material between the side sill and rigid rack, or the side sill area will be damaged.

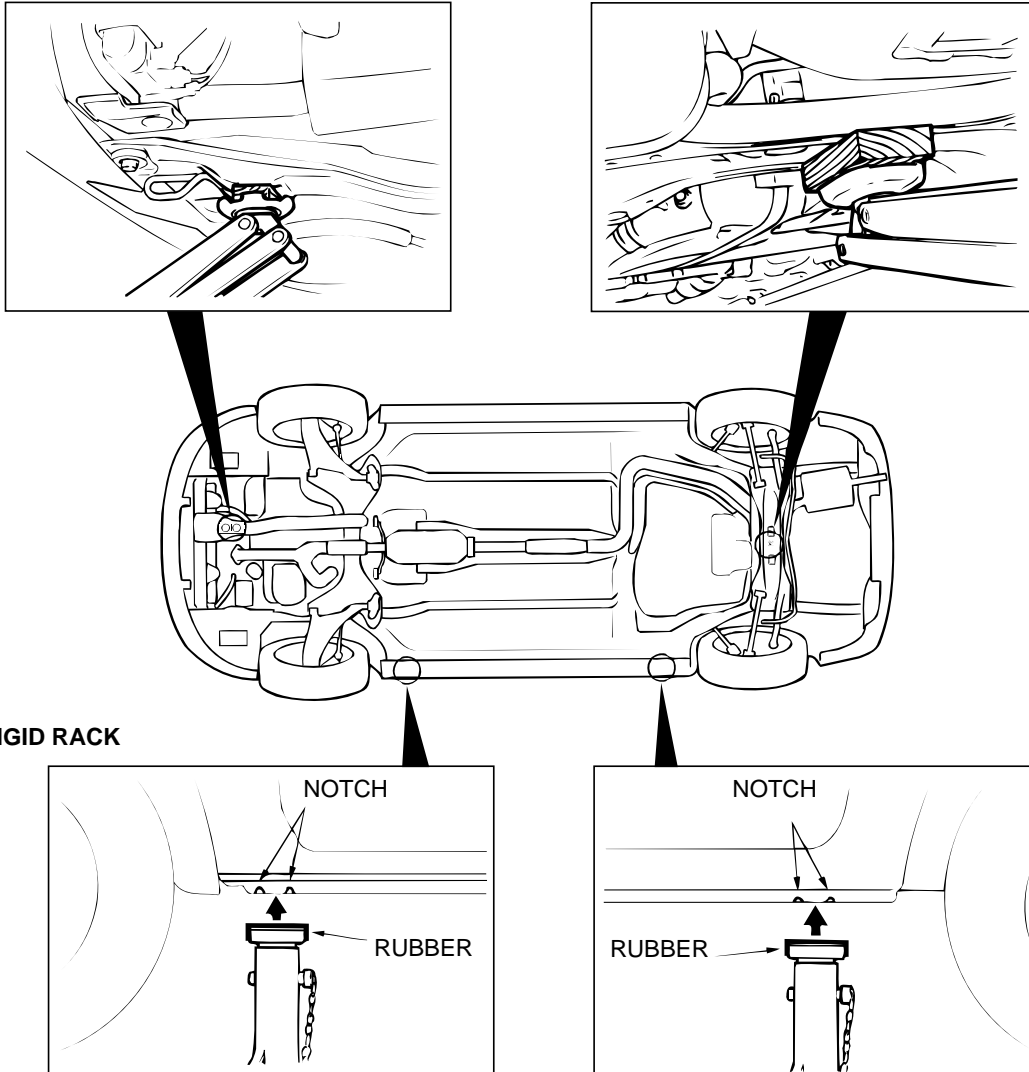

RIGID RACK

AC000072AB

POST TYPE

Special care should be taken when raising the vehicle on a frame contact type hoist. The hoist must be equipped with the proper adapters in order to support the vehicle at the proper locations.

TSB Revision

⚠ CAUTION

When service procedures require removing rear suspension, fuel tank and spare tire, place additional weight on rear end of vehicle or anchor vehicle to hoist to prevent tipping of center of gravity changes.

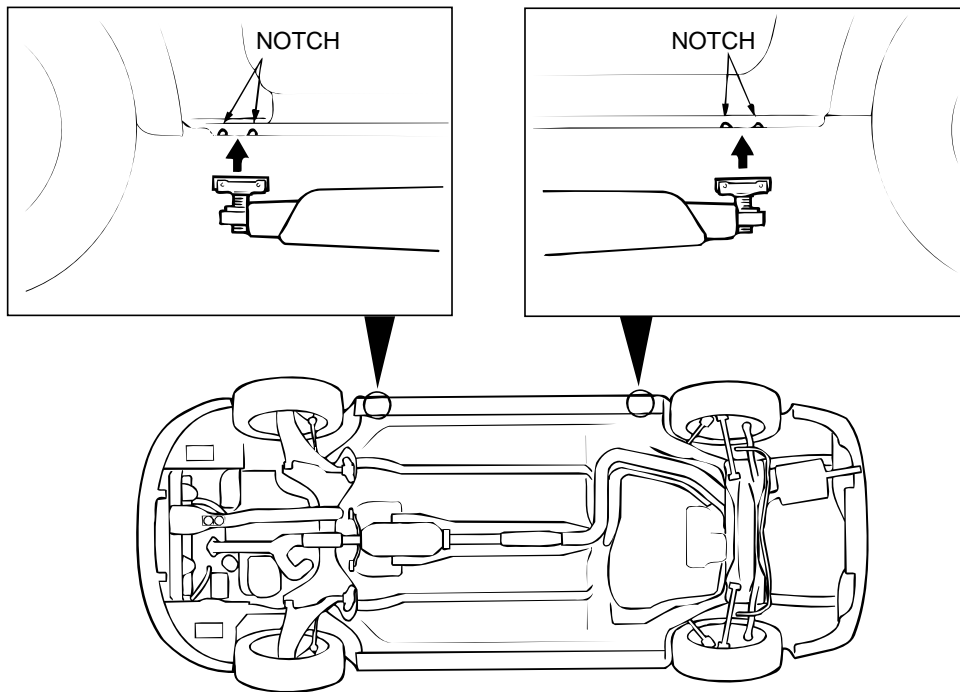

AC000073AB

GENERAL DATA AND SPECIFICATIONS

M1001000900097

<ECLIPSE >

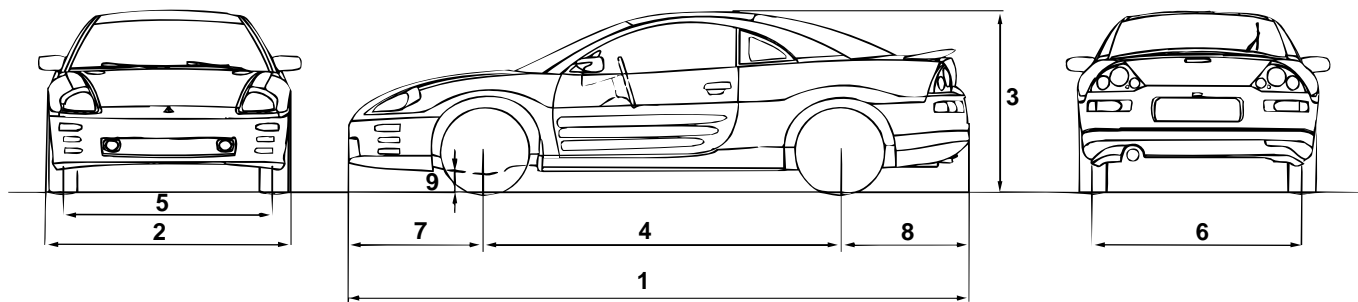

AC002714 AB

GENERAL SPECIFICATIONS (Model with 2.4L Engine)

ITEMS			RS MNJEL4M	RS MRJEL4M	GS MNH4L4M	RS MRHEL4M
Vehicle dimension mm (in)	Overall length	1	4,455 (175.4)	4,455 (175.4)	4,455 (175.4)	4,455 (175.4)
	Overall width	2	1,750 (68.9)	1,750 (68.9)	1,750 (68.9)	1,750 (68.9)
	Overall height (unladen)	3	1,310 (51.6)	1,310 (51.6)	1,310 (51.6)	1,310 (51.6)
	Wheelbase	4	2,560 (100.8)	2,560 (100.8)	2,560 (100.8)	2,560 (100.8)
	Tread-front	5	1,510 (59.4)	1,510 (59.4)	1,510 (59.4)	1,510 (59.4)
	Tread-rear	6	1,510 (59.4)	1,510 (59.4)	1,510 (59.4)	1,510 (59.4)
	Overhang-front	7	975 (38.4)	975 (38.4)	975 (38.4)	975 (38.4)
	Overhang-rear	8	920 (36.2)	920 (36.2)	920 (36.2)	920 (36.2)
	Minimum running ground clearance	9	148 (5.8)	148 (5.8)	148 (5.8)	148 (5.8)
Vehicle weight kg (lb)	Curb weight		1,295 (2,855)	1,325 (2,922)	1,335 (2,944)	1,365 (3,010)
	Gross vehicle weight rating		1,750 (3,859)	1,750 (3,859)	1,750 (3,859)	1,750 (3,859)
	Gross axle weight rating-front		1,005 (2,216)	1,005 (2,216)	1,065 (2,348)	1,065 (2,348)
	Gross axle weight rating-rear		795 (1,753)	795 (1,753)	795 (1,753)	795 (1,753)
Seating capacity			4			
Engine	Model No.		4G64			
	Piston displacement		2.4L			
Transaxle	Model No.		F5M42	F4A42	F5M42	F4A42
	Type		5-speed manual	4-speed automatic	5-speed manual	4-speed automatic
Fuel system	Fuel supply system		Electronic controlled multiport fuel injection			

GENERAL SPECIFICATIONS (Model with 3.0L Engine)

TSB Revision

ITEMS			GT MNXEL4M	GT MRXEL4M	GT MNGEL4M	GT MRGEL4M
Vehicle dimension mm (in)	Overall length	1	4,455 (175.4)	4,455 (175.4)	4,455 (175.4)	4,455 (175.4)
	Overall width	2	1,750 (68.9)	1,750 (68.9)	1,750 (68.9)	1,750 (68.9)
	Overall height (unladen)	3	1,310 (51.6)	1,310 (51.6)	1,310 (51.6)	1,310 (51.6)
	Wheelbase	4	2,560 (100.8)	2,560 (100.8)	2,560 (100.8)	2,560 (100.8)
	Tread-front	5	1,510 (59.4)	1,510 (59.4)	1,510 (59.4)	1,510 (59.4)
	Tread-rear	6	1,510 (59.4)	1,510 (59.4)	1,510 (59.4)	1,510 (59.4)
	Overhang-front	7	975 (38.4)	975 (38.4)	975 (38.4)	975 (38.4)
	Overhang-rear	8	920 (36.2)	920 (36.2)	920 (36.2)	920 (36.2)
	Minimum running ground clearance	9	150 (5.9)	150 (5.9)	150 (5.9)	150 (5.9)
Vehicle weight kg (lb)	Curb weight		1,415 (3,120)	1,445 (3,186)	1,460 (3,219)	1,460 (3,219)
	Gross vehicle weight rating		1,810 (3,991)	1,810 (3,991)	1,810 (3,991)	1,810 (3,991)
	Gross axle weight rating-front		1,065 (2,345)	1,065 (2,345)	1,065 (2,345)	1,065 (2,345)
	Gross axle weight rating-rear		795 (1,753)	795 (1,753)	795 (1,753)	795 (1,753)
Seating capacity			4			
Engine	Model No.		6G72			
	Piston displacement		3.0L			
Transaxle	Model No.		F5M51	F4A52	F5M51	F4A51
	Type		5-speed manual	4-speed automatic	5-speed manual	4-speed automatic
Fuel system	Fuel supply system		Electronic controlled multiport fuel injection			

<ECLIPSE SPYDER>

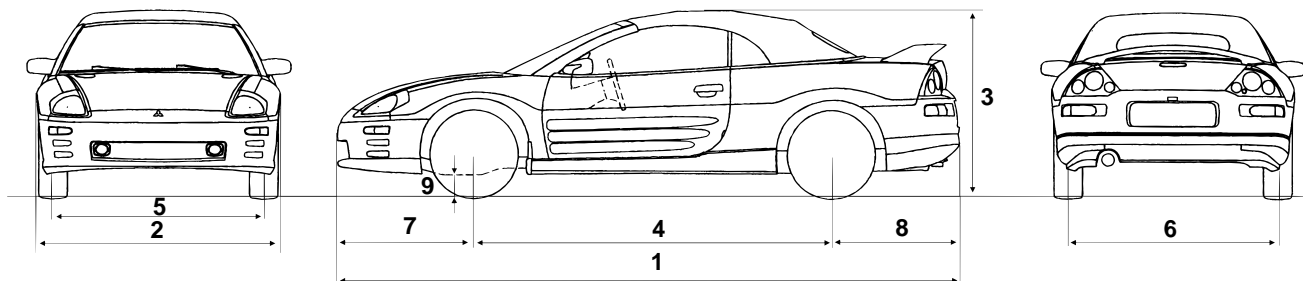

AC002712 A

GENERAL SPECIFICATIONS

ITEMS			GS HNHEL 4D	GS HRHEL 4D	GT NGEL4M	GT RGEL4M
Vehicle dimension mm (in)	Overall length	1	4,455 (175.4)	4,455 (175.4)	4,455 (175.4)	4,455 (175.4)
	Overall width	2	1,750 (68.9)	1,750 (68.9)	1,750 (68.9)	1,750 (68.9)
	Overall height (unladen)	3	1,340 (52.8)	1,340 (52.8)	1,340 (52.8)	1,340 (52.8)
	Wheelbase	4	2,560 (100.8)	2,560 (100.8)	2,560 (100.8)	2,560 (100.8)
	Tread-front	5	1,510 (59.4)	1,510 (59.4)	1,510 (59.4)	1,510 (59.4)
	Tread-rear	6	1,510 (59.4)	1,510 (59.4)	1,510 (59.4)	1,510 (59.4)
	Overhang-front	7	975 (38.4)	975 (38.4)	975 (38.4)	975 (38.4)
	Overhang-rear	8	920 (36.2)	920 (36.2)	920 (36.2)	920 (36.2)
	Minimum running ground clearance	9	163 (6.4)	163 (6.4)	165 (6.5)	165 (6.5)
Vehicle weight kg (lb)	Curb weight		1,395 (3,075)	1,425 (3,142)	1485 (3,274)	1515 (3,340)
	Gross vehicle weight rating		1,770 (3,903)	1,770 (3,903)	1,855 (4,090)	1,855 (4,090)
	Gross axle weight rating-front		1,010 (2,227)	1,010 (2,227)	1,085 (2,392)	1,085 (2,392)
	Gross axle weight rating-rear		810 (1,786)	810 (1,786)	820 (1,808)	820 (1,808)
Seating capacity			4			
Engine	Model No.		4G64		6G72	
	Piston displacement		2.4L		3.0L	
Transaxle	Model No.		F5M42	F4A42	F5M51	F4A51
	Type		5-speed manual	4-speed automatic	5-speed manual	4-speed automatic
Fuel system	Fuel supply system		Electronic controlled multiport fuel injection			

TIGHTENING TORQUE

Each torque value in the table is a standard value for tightening under the following conditions.

1. Bolts, nuts and washers are all made of steel and plated with zinc.
2. The threads and bearing surface of bolts and nuts are all in dry condition.

The values in the table are not applicable:

1. If toothed washers are inserted.
2. If plastic parts are fastened.
3. If bolts are tightened to plastic or die-cast inserted nuts.
4. If self-tapping screws or self-locking nuts are used

Standard bolt and nut tightening torque

THREAD SIZE		STANDARD TIGHTENING TORQUE		
NOMINAL BOLT DIAMETER (mm)	PITCH (mm)	HEAD MARK "4"	HEAD MARK "7"	HEAD MARK "8"
M5	0.8	2.5±0.5 N·m (23±4 in-lb)	5.0±1.0 N·m (44±9 in-lb)	6.0±1.0 N·m (53±9 in-lb)
M6	1.0	5.0±1.0 N·m (44±9 in-lb)	9.0±2.0 N·m (79±18 in-lb)	10±2 N·m (89±17 in-lb)
M8	1.25	12±2 N·m (107±17 in-lb)	22±4 N·m (16±3 ft-lb)	25±4 N·m (18±3 ft-lb)
M10	1.25	24±4 N·m (18±3 ft-lb)	44±10 N·m (33±7 ft-lb)	53±7 N·m (39±5 ft-lb)
M12	1.25	41±8 N·m (30±6 ft-lb)	83±12 N·m (61±9 ft-lb)	98±12 N·m (72±9 ft-lb)
M14	1.5	73±12 N·m (54±9 ft-lb)	140±20 N·m (104±14 ft-lb)	155±25 N·m (115±18 ft-lb)
M16	1.5	110±20 N·m (81±15 ft-lb)	210±30 N·m (155±22 ft-lb)	235±35 N·m (174±25 ft-lb)
M18	1.5	165±25 N·m (122±18 ft-lb)	300±40 N·m (222±29 ft-lb)	340±50 N·m (251±37 ft-lb)
M20	1.5	225±35 N·m (166±26 ft-lb)	410±60 N·m (303±44 ft-lb)	480±70 N·m (354±52 ft-lb)
M22	1.5	300±40 N·m (222±29 ft-lb)	555±85 N·m (410±62 ft-lb)	645±95 N·m (476±70 ft-lb)
M24	1.5	395±55 N·m (292±40 ft-lb)	735±105 N·m (543±77 ft-lb)	855±125 N·m (631±92 ft-lb)

Flange bolt and nut tightening torque

THREAD SIZE		STANDARD TIGHTENING TORQUE		
NOMINAL BOLT DIAMETER (mm)	PITCH (mm)	HEAD MARK "4"	HEAD MARK "7"	HEAD MARK "8"
M6	1.0	5.0±1.0 N·m (44±9 in-lb)	10±2 N·m (89±17 in-lb)	12±2 N·m (107±17 in-lb)
M8	1.25	13±2 N·m (111±22 in-lb)	24±4 N·m (18±3 ft-lb)	27±5 N·m (20±4 ft-lb)
M10	1.25	26±4 N·m (19±3 ft-lb)	49±9 N·m (36±7 ft-lb)	58±7 N·m (43±5 ft-lb)

THREAD SIZE		STANDARD TIGHTENING TORQUE		
NOMINAL BOLT DIAMETER (mm)	PITCH (mm)	HEAD MARK "4"	HEAD MARK "7"	HEAD MARK "8"
M10	1.5	24±4 N·m (18±3 ft-lb)	45±8 N·m (33±6 ft-lb)	55±10 N·m (41±7 ft-lb)
M12	1.25	46±8 N·m (34±6 ft-lb)	95±15 N·m (70±11 ft-lb)	105±15 N·m (78±11 ft-lb)
M12	1.75	43±8 N·m (32±6 ft-lb)	83±12 N·m (61±9 ft-lb)	98±12 N·m (72±9 ft-lb)

LUBRICATION AND MAINTENANCE

M1001001200091

Maintenance and lubrication service recommendations have been compiled to provide maximum protection for the vehicle owner's investment against all reasonable types of driving conditions. Since these conditions vary with the individual vehicle owner's driving habits, the area in which the vehicle is operated and the type of driving to which the vehicle is subjected, it is necessary to prescribe lubrication and maintenance service on a time frequency as well as mileage interval basis.

Oils, lubricants and greases are classified and graded according to standards recommended by the Society of Automotive Engineers (SAE), the American Petroleum Institute (API) and the National Lubricating Grease Institute (NLGI).

MAINTENANCE SCHEDULES

Information for service maintenance is provided in the "SCHEDULED MAINTENANCE TABLE." Three schedules are provided; one for "Required Maintenance," one for "General Maintenance and " and one for "Severe Usage Service."

The item numbers in "SCHEDULED MAINTENANCE TABLE" correspond to the section numbers in "MAINTENANCE SERVICE."

SEVERE SERVICE

Vehicles operating under severe service conditions will require more frequent service.

Component service information is included in appropriate units for vehicles operating under one or more of the following conditions:

1. Trailer towing or police, taxi or commercial type operation.
2. Operation of Vehicle
 - (1) Short-trip operation at freezing temperature (engine not thoroughly warmed up)
 - (2) More than 50% operation in heavy city traffic during hot weather above 32°C (90°F)
 - (3) Extensive idling
 - (4) Driving in sandy areas
 - (5) Driving in salty areas
 - (6) Driving in dusty conditions
 - (7) Driving off-road

ENGINE OIL

CAUTION

Test results submitted to EPA have shown that laboratory animals develop skin cancer after prolonged contact with used engine oil. Accordingly, the potential exists for humans to develop a number of skin disorders, including cancer, from such exposure to used engine oil. Therefore, when changing engine oil, be careful not to touch it as much as possible. Protective clothing and gloves, that cannot be penetrated by oil, should be worn. The skin should be thoroughly washed with soap and water, or use waterless hand cleaner, to remove any used engine oil. Do not use gasoline, thinners, or solvents.

Either of the following engine oils should be used:

1. Engine oil displaying ILSAC certification mark.
2. Engine oil conforming to the API classification SJ EC or SJ/CD EC.

For further details, refer to "LUBRICANTS SELECTION."

LUBRICANTS AND GREASES

Semi-solid lubricants bear the NLGI designation and are further classified as grades 0, 1, 2, 3, etc. Whenever "Chassis Lubricant" is specified, Multipurpose Grease, NLGI grade Number 2, should be used.

FUEL USAGE STATEMENT**⚠ CAUTION**

Using leaded gasoline in your car will damage the catalytic converters and heated oxygen sensors, and affect the warranty coverage validity.

This vehicle must use unleaded gasoline only. This vehicle has a fuel filler tube which is especially designed to accept only the smaller-diameter unleaded gasoline dispensing nozzle.

2.4L model is designed to operate on unleaded gasoline having a minimum octane rating of 87 [(MON + RON)/2], or 91 RON.

3.0L model is designed to operate on premium grade unleaded gasoline having a minimum octane rating of 91 [(MON + RON)/2], or 95 RON. If premium grade unleaded gasoline is not available, unleaded gasoline having an octane rating of 87 [(MON + RON)/2], or 91 RON may be used. However, the performance level may be reduced.

MON: Motor Octane Number

RON: Research Octane Number

GASOLINE CONTAINING ALCOHOL

Some gasoline sold at service stations contain alcohol although they may not be so identified.

Using fuels containing alcohol is not recommended unless the nature of the blend can be determined as being satisfactory.

Gasohol: A mixture of 10% ethanol (grain alcohol) and 90% unleaded gasoline may be used in your vehicle. If driveability problems are experienced as a result of using gasohol, it is recommended that the vehicle be operated on gasoline.

Methanol: **Do not use gasoline containing methanol (wood alcohol).** Using this type of alcohol can result in vehicle performance deterioration and damage critical parts in the fuel system components. Fuel system damage and performance problems resulting from the use of gasoline containing methanol may not be covered by the new vehicle warranty.

GASOLINE CONTAINING METHY TERTIARY BUTYL ETHER (MTBE)

Unleaded gasoline containing 15% or less MTBE may be used in your vehicle. (Fuel containing MTBE over 15% in volume may cause reduced engine performance and produce vapor lock or hard starting.

MATERIALS ADDED TO FUEL

Indiscriminate use of fuel system cleaning agents should be avoided. Many of these materials intended for gum and varnish removal may contain highly active solvents or similar ingredients that can be harmful to gasket and diaphragm materials used in fuel system component parts.

RECOMMENDED LUBRICANTS AND LUBRICANT CAPACITIES TABLE

M1001001300098

RECOMMENDED LUBRICANTS

PARTS	SPECIFICATIONS	REMARKS
Engine oil	Engine oil displaying ILSAC certification mark ("Starburst" symbol) conforming the API classification SJ EC or SJ/CD EC	For further details, refer to "LUBRICANTS SELECTION" section.
Manual transaxle	API classification GL-4	SAE grade number:SAE75W-90 or 75W/85W
Automatic transaxle	-	-
Power steering	MITSUBISHI POWER STEERING FLUID	-
Brakes	Conforming to DOT 3 or DOT 4	-
Engine coolant	MITSUBISHI genuine coolant or an equivalent	-
Door hinges, back door hinges	Engine oil	-

TSB Revision

LUBRICANT CAPACITY TABLE

DESCRIPTION		SPECIFICATIONS
Engine oil dm ³ (qt)	Oil pan (excluding oil filter)	4.0 (4.2)
	Oil filter	0.3 (0.32)
Engine coolant dm ³ (qt)	2.4L engine	7.0 (7.4)
Engine coolant dm ³ (qt)	3.0L engine	8.0 (8.5)
Manual transaxle dm ³ (qt)	2.4L engine	2.2 (2.3)
Manual transaxle dm ³ (qt)	3.0L engine	2.8 (3.0)
Automatic transmission dm ³ (qt)	2.4L engine	7.7 (8.1)
Automatic transmission dm ³ (qt)	3.0L engine	8.4 (8.5)
Power steering dm ³ (qt)		1.2 (1.3)
Fuel tank dm ³ (gal)		62 (16.4)

LUBRICANT SELECTION

ENGINE OIL

⚠ CAUTION

Never use nondetergent or straight mineral oil.

Oil Identification Symbol

Use only engine oils displaying the ILSAC certification mark ("Starburst" symbol) on the container.

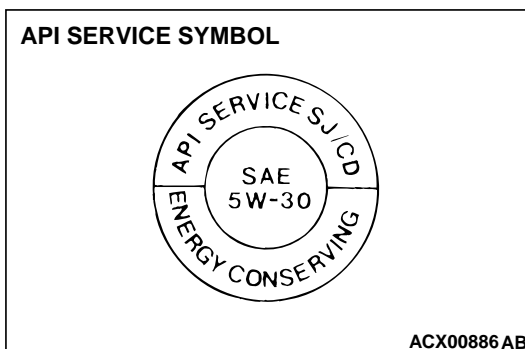
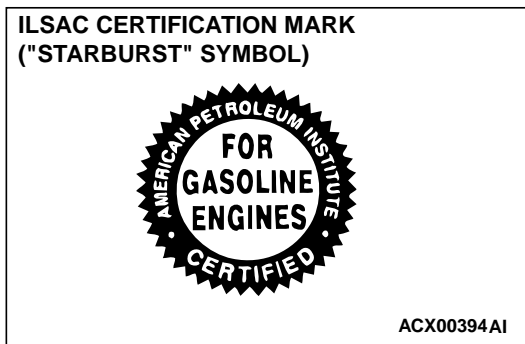

If these oils are not available, an API classification SJ EC or SJ/CD EC can be used.

Oil Viscosity

The SAE grade number indicates the viscosity of the oil. A proper SAE grade number should be selected according to ambient temperature.

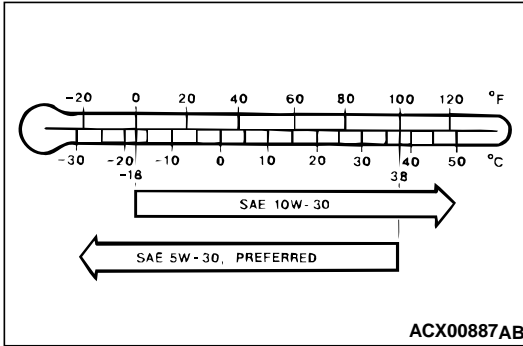

SELECTION OF COOLANT

COOLANT

Relationship between Coolant Concentration and Specific Gravity

CAUTION

- If the concentration of the coolant is below 30%, the anti-corrosion property will be adversely affected. In addition, if the concentration is above 60%, both the anti-freeze and engine cooling properties will decrease, affecting the engine adversely. For these reasons, be sure to maintain the concentration level within the specified range.
- Do not use a mixture of different brands of anti-freeze.

COOLANT TEMPERATURE °C (°F) AND SPECIFIC GRAVITY					FREEZING TEMPERATURE	SAFE OPERATING TEMPERATURE	COOLANT CONCENTRATION (SPECIFIC VOLUME)
10 (50)	20 (68)	30 (86)	40 (104)	50 (122)	°C (°F)	°C (°F)	%
1.054	1.050	1.046	1.042	1.036	-16 (3.2)	-11 (12.2)	30
1.063	1.058	1.054	1.049	1.044	-20 (-4)	-15 (5)	35
1.071	1.067	1.062	1.057	1.052	-25 (-13)	-20 (-4)	40
1.079	1.074	1.069	1.064	1.058	-30 (-22)	-25 (-13)	45
1.087	1.082	1.076	1.070	1.064	-36 (-32.8)	-31 (-23.8)	50
1.095	1.090	1.084	1.077	1.070	-42 (-44)	-37 (-35)	55
1.103	1.098	1.092	1.084	1.076	-50 (-58)	-45 (-49)	60

Example

The safe operating temperature is -15°C (5° F) when the specific gravity is 1.058 at the coolant temperature of 20°C (68°F).

SCHEDULED MAINTENANCE TABLE

M1001001400103

SCHEDULED MAINTENANCE SERVICE FOR EMISSION CONTROL AND PROPER VEHICLE PERFORMANCE

Inspection and service should be performed any time a malfunction is observed or suspected.

NO.	EMISSION CONTROL SYSTEM MAINTENANCE	SERVICE INTERVALS	KILOMETERS IN THOUSANDS	24	48	72	96	120	144	168
			MILEAGE IN THOUSANDS	15	30	45	60	75	90	105
1	Fuel system (tank, pipe line and connection, and fuel tank filler tube cap)	Check for leaks every 5 years or					X			
2	Fuel hoses	Check condition every 2 years or			X		X		X	
3	Air cleaner element	Replace at			X		X		X	
4	Evaporative emission control system (except evaporative emission canister)	Check for leaks and clogging every 5 years or					X			
5	Spark plugs	Replace at	Except platinum plugs at		X		X		X	
			Platinum plugs only at				X			
6	Ignition cables	Replace every 5 years or					X			
7	Distributor cap and rotor	Check every 5 years					X			

GENERAL MAINTENANCE SERVICE FOR PROPER VEHICLE PERFORMANCE

NO.	GENERAL MAINTENANCE	SERVICE INTERVALS	KILOMETERS IN THOUSANDS	24	48	72	96	120	144	168
			MILEAGE IN THOUSANDS	15	30	45	60	75	90	105
8	Timing belt	Replace at					X ^{*1}			At 160,000 km ^{*2} (100,000 miles)
9	Drive belt (for generator, water pump, A/C compressor and power steering pump)	Check condition at			X		X		X	
10	Engine oil	Change oil every 12 months or		Every 12,000 km (7,500 miles)						
11	Engine oil filter	Replace every 12 months or ^{*3}		X	X	X	X	X	X	X
12	Manual transmission oil	Check oil level every at			X		X		X	

NO.	GENERAL MAINTENANCE	SERVICE INTERVALS	KILOMETERS IN THOUSANDS	24	48	72	96	120	144	168
			MILEAGE IN THOUSANDS	15	30	45	60	75	90	105
13	Automatic transmission fluid* ⁴	Check A/T fluid level every 12 months or		X	X	X	X	X	X	X
14	Engine coolant	Change	at first 4 years or				X			
			After that every 2 years or				Every 48,000km /h (30,000 miles)	X		
15	Disc brake pads	Inspect for wear every 12 months or		X	X	X	X	X	X	X
16	Rear drum brake linings and rear wheel cylinders	Inspect for wear and leaks every 2 years or			X		X		X	
17	Brake hoses	Check for deterioration or leaks every 12 months or		X	X	X	X	X	X	X
18	Ball joint and steering linkage seals	Inspect for grease leaks and damage every 2 years or			X		X		X	
19	Drive shaft boots	Inspect for grease leaks and damage every 12 months or		X	X	X	X	X	X	X
20	SRS air bag	Inspect the SRS system at		10 years						
21	Exhaust system (connection portion of muffler, piping and converter heat shields)	Check and service as required every 2 years or			X		X		X	
22	Tires	Rotate every 12 months or		Every 12,000 km (7,500 miles)						
23	Air purifier filter	Replace every 12 months or		Every 12,000 km (7,500 miles)						

NOTE:

*1: For California, this maintenance is recommended but not required

*2: Not required if belt was previously changed

*3: If the mileage is less than 12,000 km (7,500 miles) each year, the oil filter should be replaced at every oil change.

*4: Change fluid under severe usage conditions only.

SCHEDULED MAINTENANCE UNDER SEVERE USAGE CONDITIONS

Maintenance should be carried out according to the following table:

NO.	MAINTENANCE ITEM	SERVICE INTERVALS	KILOMETERS IN THOUSANDS								SEVERE USAGE CONDITIONS
			24	48	72	96	120	144	168	MILEAGE IN THOUSANDS	
			15	30	45	60	75	90	105		
3	Air cleaner element	Replace at	X	X	X	X	X	X	X	X	A and E
5	Spark plugs	Replace at	X	X	X	X	X	X	X	X	B and D
10	Engine oil	Change every 3 months or	Every 4,800 km (3,000 miles)								A, B, C, D and G
11	Engine oil filter	Replace every 6 months or	Every 9,600 km (6,000 miles)								A, B, C, D and G
12	Manual transmission oil	Change oil at		X		X		X			B, G and H
13	Automatic transmission fluid	Change A/T fluid at		X		X		X			B, G and H
15	Disc brake pads	Inspect for wear every 6 months or	Every 9,600 km (6,000 miles)								A and F
16	Rear drum brake linings and rear wheel cylinders	Inspect for wear every 12 months or	Every 2,400 km (15,000 miles)								A and F
22	Tires	Rotate every 6 months or	Every 9,600 km (6,000 miles)								B, C, E, G and H

Sever usage conditions:

A: Driving in dusty conditions

B: Trailer towing, or police, taxi, or commercial type operation

C: Extensive idling, driving in stop and go traffic

D: Short-trip operation at freezing temperatures (engine not thoroughly warmed up)

E: Driving in sandy areas

F: Driving in salty areas

G: More than 50% operation in heavy city traffic or at sustained high speeds during hot weather above 32°C (90°F)

H: Driving off-road

MAINTENANCE SERVICE**1. FUEL SYSTEM (TANK, PIPE LINE AND CONNECTION, AND FUEL TANK FILLER TUBE CAP) (CHECK FOR LEAKS)**

M1001001600099

1. Check for damage or leakage in the fuel lines and connections.
2. Inspect the surface of fuel hoses for heat and mechanical damage. Hard and brittle rubber, cracking, checking, tears, cuts, abrasions and excessive swelling indicate deterioration of the rubber.
3. If the fabric casing of the rubber hose is exposed by cracks and abrasions in the fuel system, the hoses should be replaced.

2. FUEL HOSES (CHECK CONDITION)

M1001001700096

1. Inspect the surface of fuel hoses for heat and mechanical damage. Hard and brittle rubber, cracking, tears, cuts, abrasions and excessive swelling indicate deterioration of the rubber.
2. If the fabric casing of the rubber hose is exposed by cracks and abrasions in the fuel system, the hoses should be replaced.

3. AIR CLEANER ELEMENT (REPLACE)

M1001001800093

The air cleaner element will become dirty during use, reducing its effect. Replace it with a new one.

REPLACEMENT OF AIR CLEANER ELEMENT

1. Unclamp the air cleaner cover.
2. Remove the air cleaner element and install a new one.
3. When clamping the air cleaner cover in place, be sure that the cover is completely closed.

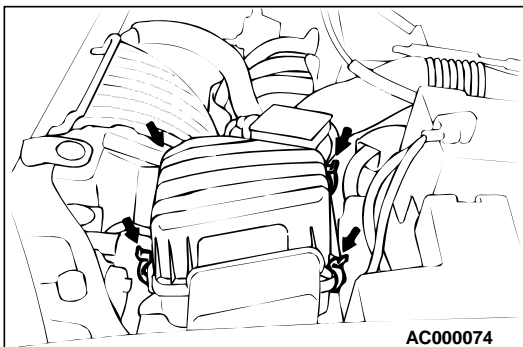
**4. EVAPORATIVE EMISSION CONTROL SYSTEM (EXCEPT EVAPORATIVE EMISSION CANISTER) (CHECK FOR LEAKS AND CLOGGING)**

M1001001900090

If the fuel-vapor vent line is clogged or damaged, the fuel vapor mixture will escape into the atmosphere causing excessive emissions. Disconnect the line at both ends, and blow it clean with compressed air. Remove the fuel tank filler tube cap from the filler tube and check to see if there is evidence that the packing makes improper contact to the filler tube.

5. SPARK PLUGS (REPLACE)

M1001002000078

⚠ CAUTION

Platinum plugs are used on 3.0L engine. Use care not to damage the platinum tips of the platinum plugs. Do not attempt to adjust the gap on these plugs.

1. Spark plugs must spark properly to assure proper engine performance and reduce exhaust emission level. Therefore, they should be replaced periodically with new ones.

Spark plug type

MAKER	2.4L ENGINE	3.0L ENGINE
NGK	BKR5E-11	PFR6G-11
DENSO	K16PR-U11	PK20PR11
CHAMPION	RC10YC4	RC8PYP4

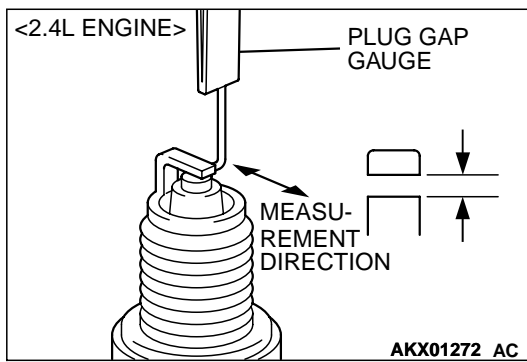
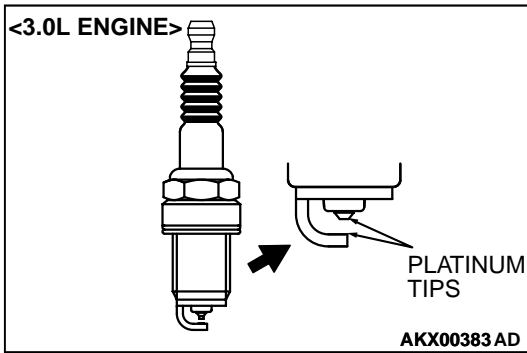

2. The new plugs should be checked for the proper gap.

Spark plug gap: 1.0 – 1.1 mm (0.039 – 0.043 inch)

3. Install the spark plugs and tighten to 25 ± 4 N·m (18 ± 4 ft-lb)

6. IGNITION CABLES (REPLACE)

M1001002100064

⚠ CAUTION

When disconnecting an ignition cable, be sure to hold the cable boot. If the cable is disconnected by pulling on the cable alone, an open circuit might result.

The ignition cables should be replaced periodically with new ones. After replacing, make sure that the ignition cables are routed properly and fully seated.

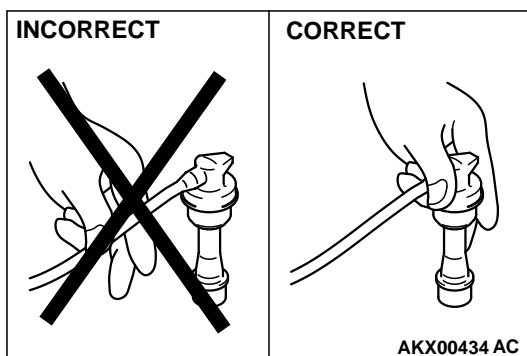

**7. DISTRIBUTOR CAP AND ROTOR (CHECK)
<3.0L ENGINE>**

M1001002200050

Check the distributor cap and rotor to maintain driveability and reduce exhaust emissions.

DISTRIBUTOR CAP AND ROTOR INSPECTION

Inspect in accordance with the following procedure. Repair or replace as necessary.

- Check the cap for cracks.
- Check the cap and rotor electrodes for damage.
- Wipe clean the cap and rotor.
- Clean the corrosion off the terminals inside the distributor cap.

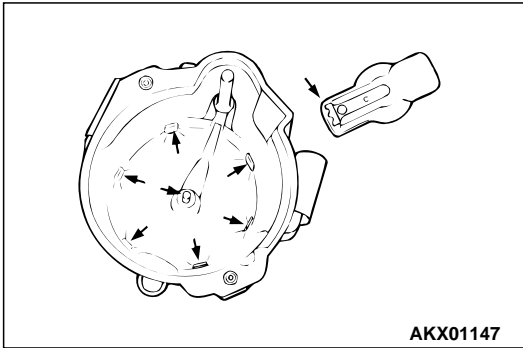
**8. TIMING BELT (REPLACE)**

M1001002300091

Replace the belt with a new one according to the maintenance schedule on [P.00-35](#) to assure proper engine performance.

For removal and installation procedures, refer to GROUP 11A, Timing Belt [P.11A-35](#) or 11C, Timing Belt [P.11A-31](#).

**9. DRIVE BELT (FOR GENERATOR, WATER PUMP,
A/C COMPRESSOR AND POWER STEERING
PUMP) (CHECK CONDITION)**

M1001002500073

**Water Pump <2.4L ENGINE>, A/C Compressor
<3.0L ENGINE> and Generator Drive Belt Tension
Check and Adjustment**

<When using scan tool MB991502>

Required Special Tools:

- MB991502: Scan Tool (MUT-II)
- MB991668: Belt Tension Meter Set

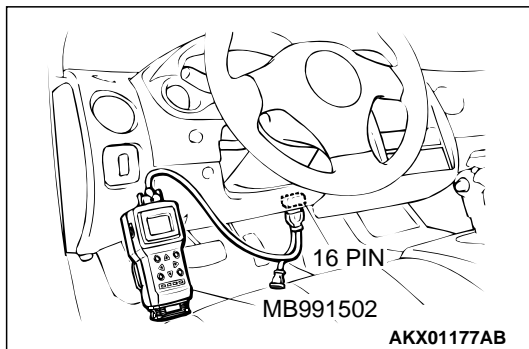

CAUTION

To prevent damage to scan tool MB991502, always turn the ignition switch to the "LOCK" (OFF) position before connecting or disconnecting scan tool MB991502.

1. Connect special tool MB991668 to the scan tool MB991502.
2. Connect scan tool MB991502 to the data link connector.
3. Turn the ignition switch to the "ON" and select scan tool MB991502 "Belt Tension Measurement" from the menu screen.
4. Hold special tool MB991668 (microphone) to the middle of the drive belt between the pulleys (at the place indicated by the arrow), about 10 – 20 mm (0.4 – 0.8 inch) away from the rear surface of the belt and so that it is perpendicular to the belt (within an angle of ± 15 degree angle).

CAUTION

- The temperature of the surface of the belt should be as close as possible to underhood temperature.
 - Do not let any contaminants such as water or oil get onto the microphone.
 - If strong gusts of wind blow against the microphone or if there are any loud sources of noise nearby, the values measured by the microphone may not correspond to actual values.
 - If the microphone is touching the belt while the measurement is being made, the values measured by the microphone may not correspond to actual values.
 - Do not take the measurement while the vehicle's engine is running.
5. Gently tap the middle of the belt between the pulleys (the place indicated by the arrow) with your finger as shown in the illustration, and check that the vibration frequency of the belt is within the standard value.

Standard value:

ITEM	2.4L ENGINE	3.0L ENGINE
Vibration frequency Hz	189 – 232	134 – 159

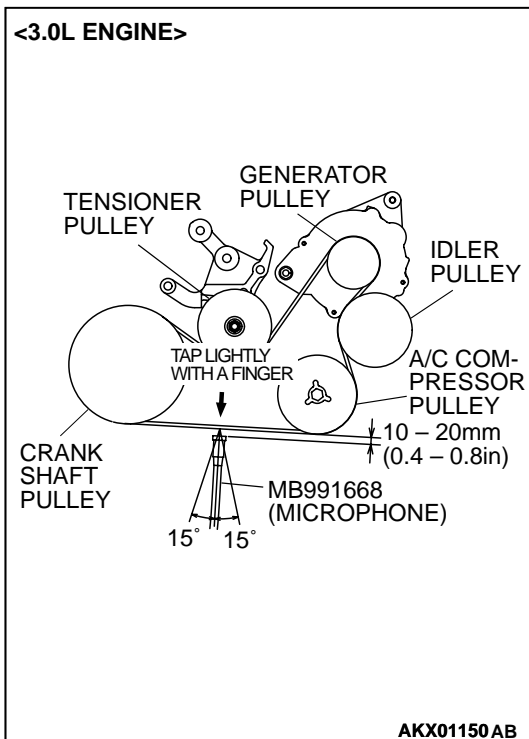
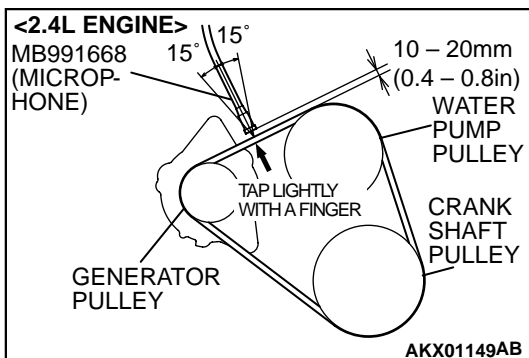

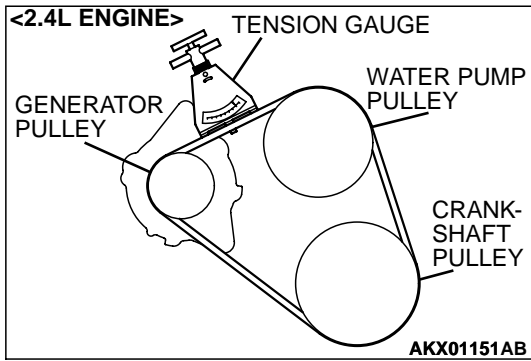

<When using the tension gauge>

Use a belt tension gauge to check that the belt tension is within the standard value.

Standard value:

ITEM	2.4L ENGINE	3.0L ENGINE
Tension N (lb)	392 – 588 (88 – 132)	490 – 686 (110 – 154)

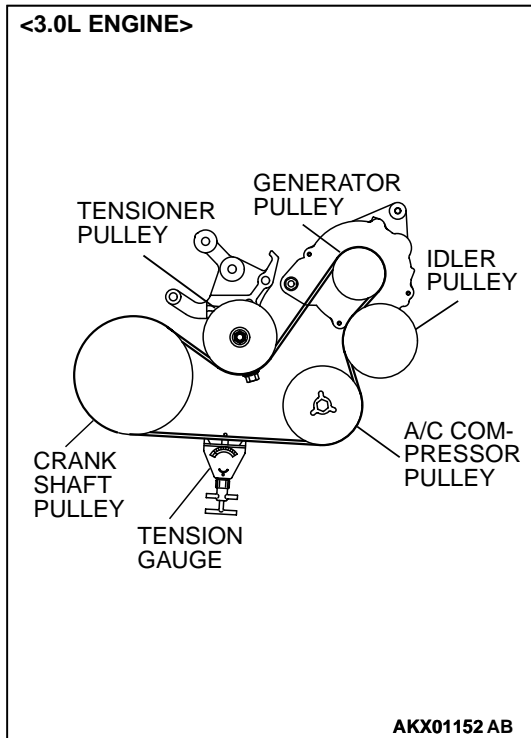

<Belt deflection check>

Apply 98 N (22 pound) of force to the middle of the drive belt between the pulleys (at the place indicated by the arrow) and check that the amount of deflection is within the standard value.

Standard value:

ITEM	2.4L ENGINE	3.0L ENGINE
Deflection (Reference value) mm (in)	6.7 – 9.0 (0.26 – 0.35)	8.5 – 10.9 (0.33 – 0.43)

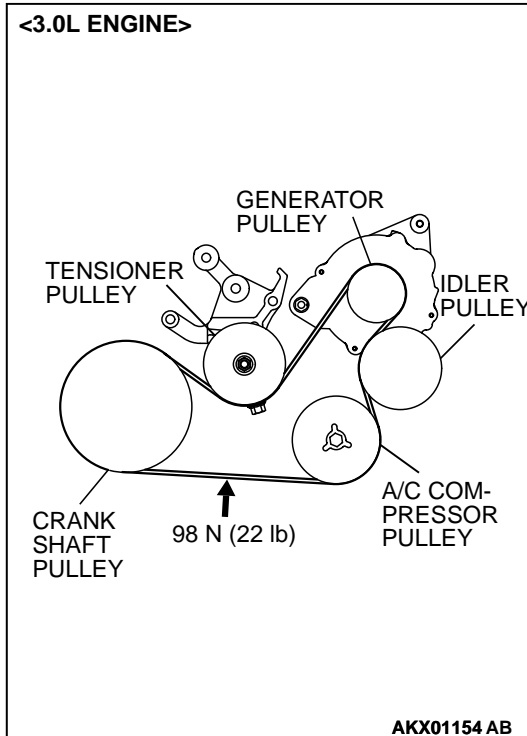
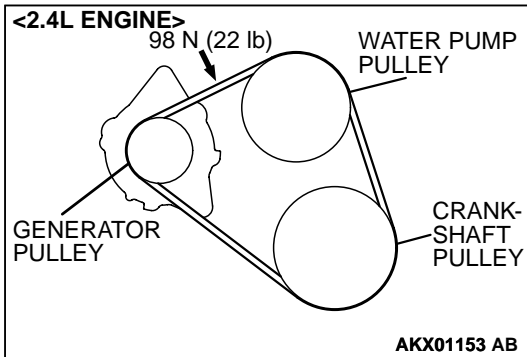

Generator Drive Belt Tension Adjustment <2.4L ENGINE>

1. Loosen the nut of the generator pivot bolt.
2. Loosen the lock bolt.
3. Turn the adjusting bolt to adjust the belt vibration frequency, belt tension or deflection to the standard value.

Standard value:

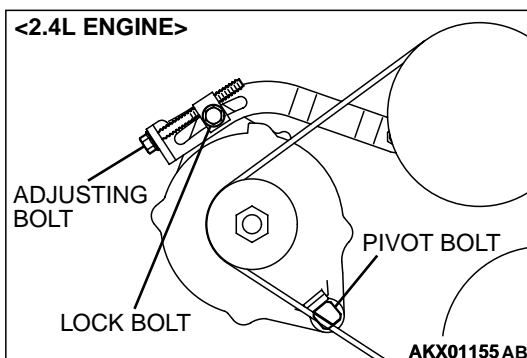

ITEMS	DURING ADJUSTMENT	DURING REPLACEMENT
Vibration frequency Hz	201 – 222	267 – 299
Tension N (lb)	441 – 539 (99 – 121)	785 – 981 (176 – 220)
Deflection (Reference value) mm (in)	7.2 – 8.4 (0.28 – 0.33)	4.4 – 5.3 (0.17 – 0.21)

4. Tighten the lock bolt.

Tightening torque: 23 ± 2 N·m (16 ± 2 ft·lb)

5. Tighten the nut of the generator pivot bolt.

Tightening torque: 44 ± 10 N·m (33 ± 7 ft·lb)

6. Tighten the adjusting bolt.

Tightening torque: 4.9 ± 1.0 N·m (44 ± 8 in·lb)

Generator and A/C Compressor Drive Belt Tension Adjustment<3.0L ENGINE>

1. Loosen the tensioner pulley fixing nut.

2. With the tensioner pulley fixing nut temporarily tightened to 15 ± 5 N·m (11 ± 4 ft·lb), set the belt tension or deflection amount to the standard value using the adjusting bolt.

Standard value:

ITEMS	DURING ADJUSTMENT	DURING REPLACEMENT
Vibration frequency Hz	141 – 153	170 – 190
Tension N (lb)	539 – 637 (121 – 143)	785 – 981 (176 – 221)
Deflection (Reference value) mm (in)	9.0 – 10.1 (0.35 – 0.40)	6.2 – 7.6 (0.24 – 0.30)

3. Tighten the tension pulley fixing nut.

Tightening torque: 49 ± 10 N·m (36 ± 7 ft·lb)

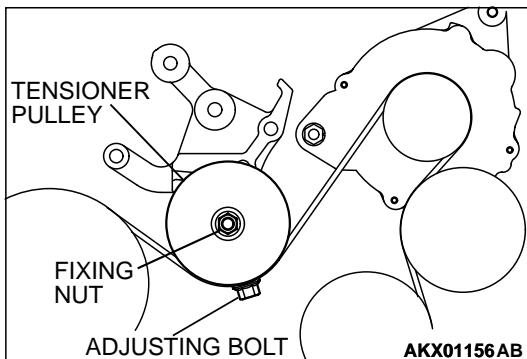

Power Steering Oil Pump and A/C Compressor <2.4L ENGINE> Drive Belt Tension Check and Adjustment

Check the drive belt tension by the following procedure.

<When using scan tool MB991502>

Required Special Tools:

- MB991502: Scan Tool (MUT-II)
- MB991668: Belt Tension Meter Set

Gently tap the middle of the belt between the pulleys (the location indicated by the arrow) with your finger as shown in the illustration, and check that the vibration frequency of the belt is within the standard value range.

NOTE: Refer to P.00-40 for details on the method of measuring the vibration frequency using the scan tool.

<When using a tension gauge>

Use a belt tension gauge to check that the belt tension is within the standard value.

<Belt deflection check>

Apply 98 N (22 pound) of force to the middle of the drive belt between the pulleys (at the place indicated by the arrow) and check that the amount of deflection is within the standard value.

Standard value:

<2.4L ENGINE>

ITEMS	WHEN CHECKED	DURING ADJUSTMENT	DURING REPLACEMENT
Vibration frequency Hz	108 – 132	114 – 126	137 – 157
Tension N (lb)	392 – 588 (88 – 132)	441 – 539 (99 – 121)	637 – 834 (143 – 187)
Deflection (Reference value) mm (in)	11.7 – 15.3 (0.46 – 0.60)	12.5 – 14.3 (0.49 – 0.56)	8.8 – 11.0 (0.35 – 0.43)

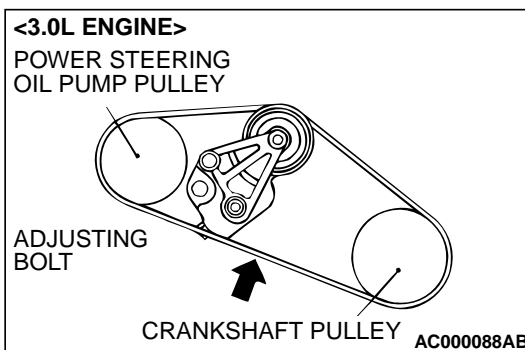
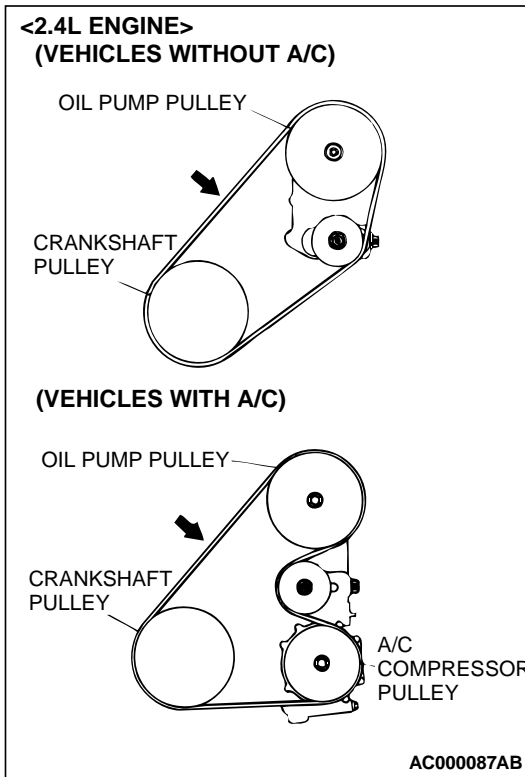

<3.0L ENGINE>

ITEMS	WHEN CHECKED	DURING ADJUSTMENT	DURING REPLACEMENT
Vibration frequency Hz	125 – 154	133 – 148	160 – 183
Tension N (lb)	373 – 569 (84 – 128)	422 – 520 (95 – 117)	608 – 804 (137 – 181)
Deflection (Reference value) mm (in)	11.0 – 14.2 (0.43 – 0.56)	11.7 – 13.4 (0.46 – 0.53)	8.4 – 9.3 (0.33 – 0.37)

if the tension or deflection is outside the standard value, adjust by the following procedure.

<2.4L ENGINE>

1. Loosen the tension pulley fixing nut A behind the tension pulley.
2. Adjust the belt deflection amount using the adjusting bolt B.
3. Tighten the fixing nut A.

Tightening torque: 44 ± 10 N·m (33 ± 7 ft-lb)

CAUTION

Check after turning the crankshaft once or more clockwise.

4. Check the belt deflection amount and tension, and readjust if necessary.

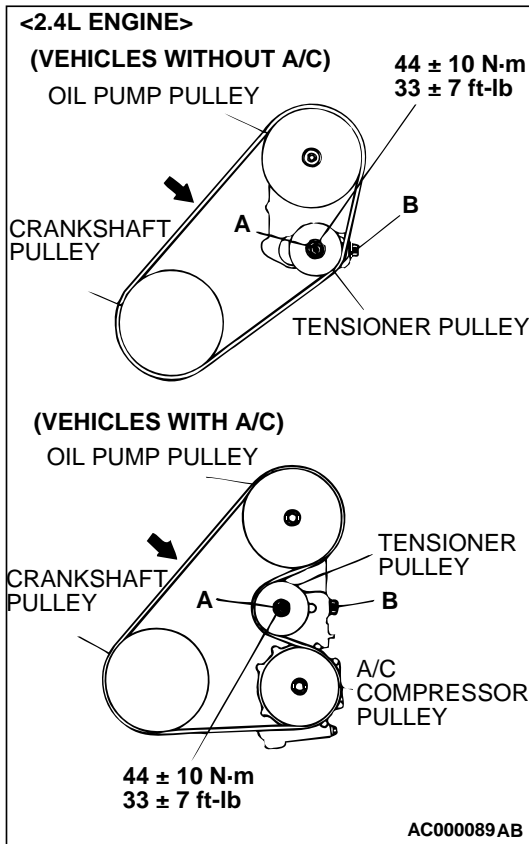

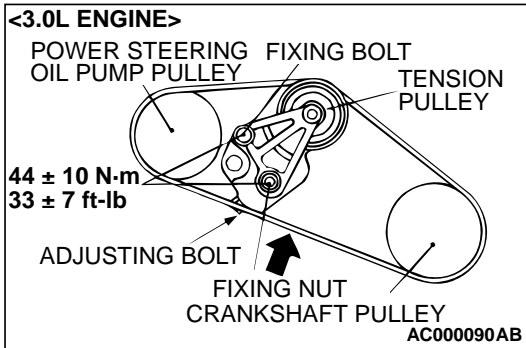

<3.0L ENGINE>

1. Loosen the tension pulley fixing nut and bolt.
2. Adjust the belt tension using the adjusting bolt.
3. Tighten the fixing nut and bolt.

Tightening torque: $44 \pm 10 \text{ N}\cdot\text{m}$ ($33 \pm 7 \text{ ft}\cdot\text{lb}$)

CAUTION

Check after turning the crankshaft once or more clockwise.

4. Check the belt deflection amount and tension, and readjust if necessary.

10. ENGINE OIL (CHANGE)

M1001002600092

Use the specified oil. (Refer to P.00-32.)

1. After warming up the engine, remove the oil filler cap.

WARNING

Use care as oil could be hot.

2. Remove the drain plug to allow the engine oil to drain.
3. Replace the drain plug gasket with a new one, and then tighten the drain plug to the specified torque.

Tightening torque: $39 \pm 5 \text{ N}\cdot\text{m}$ ($29 \pm 4 \text{ ft}\cdot\text{lb}$)

NOTE: Install the drain plug gasket so it faces in the direction shown in the illustration.

4. Pour new engine oil in through the oil filler.

Engine oil capacity:

- 4.0 dm^3 (4.5 quart)

[excluding oil filter 0.3 dm^3 (0.32 quart)]

5. Start the engine and run it at idle for a few minutes.

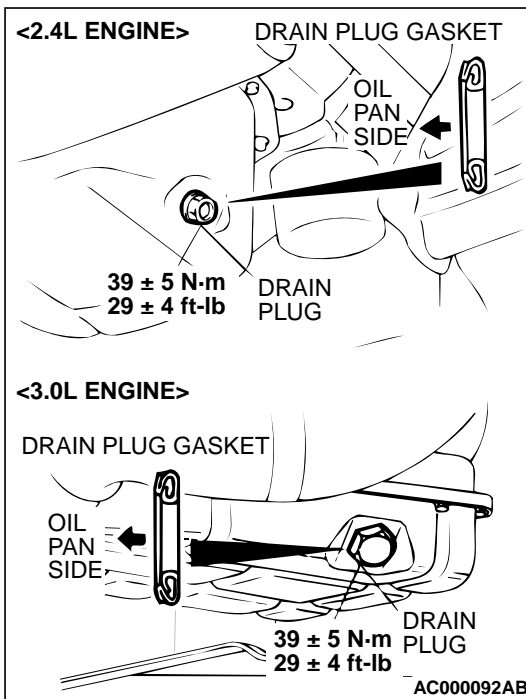

6. Stop the engine and check to ensure that the engine oil level is within the level range indicated on the dip stick.

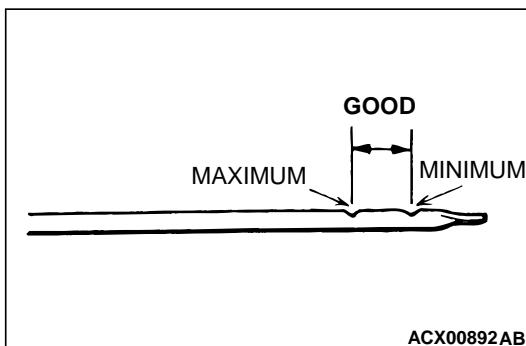

11. ENGINE OIL FILTER (REPLACE)

M1001002700099

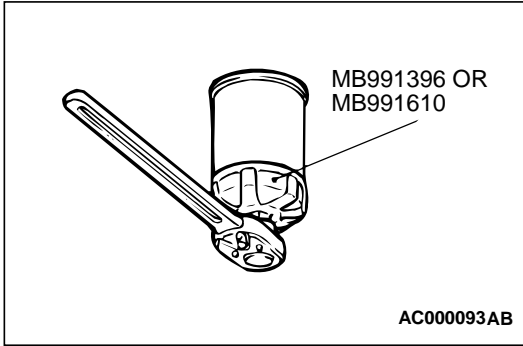

The quality of replacement filters varies considerably. Only high quality filters should be used to assure most efficient service. Genuine oil filters require that the filter is capable of withstanding a pressure of 1,765 kPa (256 psi) are high quality filters and are recommended as follows:

Mitsubishi Oil Filter Part Number:

<2.4L Engine>

MD136466, MD322508, MD325714, MD332687

MD360935, MD365876 or equivalent

<3.0L Engine>

MD352626 or equivalent

Engine Oil Filter Selection

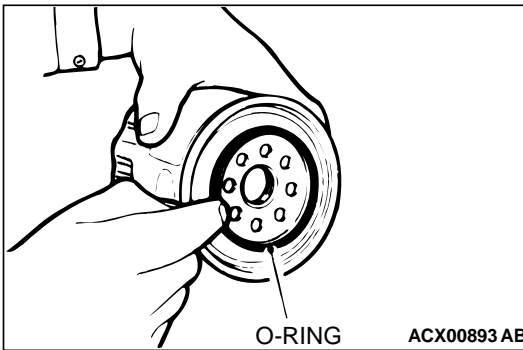

This vehicle is equipped with a full-flow, throw-away oil filter. The same type of filter is recommended as a replacement filter for this vehicle. It is possible, particularly in cold weather, that this vehicle may develop high oil pressure for a short duration. Make sure that any replacement filter used on this vehicle is a high-quality filter. The filter can withstand a pressure of 1,765 kPa (256 psi) [manufacturer's specifications] to avoid the filter and engine damage. The following is a high-quality filter and is strongly recommended for use on this vehicle: Mitsubishi Engine Oil Filter Part number MD136466, MD322508, MD325714, MD332687, MD352626, MD360935 and MD365876.

Any replacement oil filter should be installed in accordance with the oil filter manufacturer's installation instructions.

1. Drain the engine oil by removing the oil drain plug.
2. Use an oil filter wrench to remove the engine oil filter.
3. Clean the contacting surface of the filter bracket.
4. Lubricate the O-ring of the new oil filter with a small amount of new engine oil.
5. Screw on the oil filter by hand until it touches the surface of the flange and then tighten it with the oil filter wrench: etc.

NUMBER	ENGINE	SPECIAL TOOL	TIGHTENING TORQUE
MD360935	2.4L	MB991396 or equivalent	Approximately one turn [14 ± 2 N·m (124 ± 18 in-lb)]
MD325714 MD332687 MD365876		MB991396 or equivalent	Approximately 3/4 turn [16 ± 4 N·m (12 ± 3 ft-lb)]
MD136466 MD322508		General service tool	Approximately 3/4 turn [17 ± 3 N·m (34 ± 2 ft-lb)]
MD352626	3.0L	MB991610 or equivalent	Approximately one turn [14 ± 2 N·m (124 ± 18 in-lb)]

6. Add new engine oil through the oil filter.

12. MANUAL TRANSMISSION OIL

M1001002800074

Check oil level

Inspect each component for evidence of leakage, and check the oil level by removing the filler plug. If the oil is contaminated, replace with new oil.

1. Remove the filler plug.
2. Check that the oil is not noticeably dirty, and that it has a suitable viscosity.
3. Tighten the filler plug to the specified torque.

Tightening torque: 32 ± 2 N·m (24 ± 1 ft·lb)

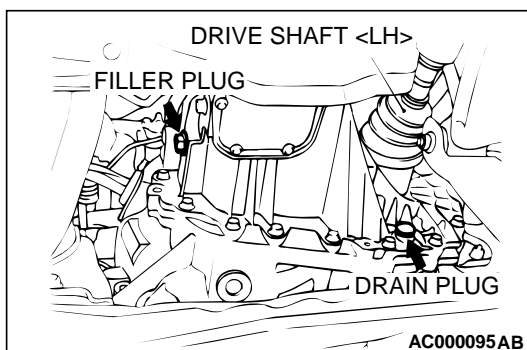
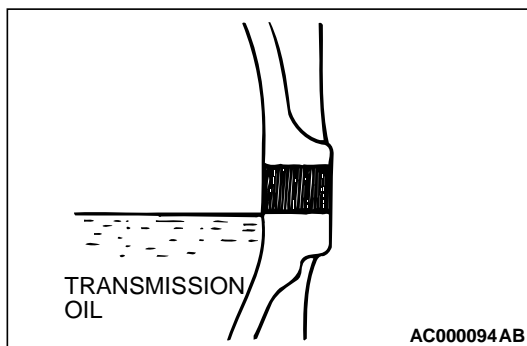

Change oil

1. Remove the filler plug.
2. Remove the drain plug and drain the oil.
3. Tighten the drain plug to the specified torque.
4. Fill with Hypoid gear oil SAE 75W-90 or 75W-85W conforming to API classification GL-4 until the level comes to the lower portion of filler plug hole.

Tightening torque: 32 ± 2 N·m (24 ± 1 ft·lb)

Quantity:

<2.4L Engine> 2.2 dm³ (2.3 quarts)

<3.0L Engine> 2.8 dm³ (3.0 quarts)

5. Tighten the filler plug to the specified torque.

Tightening torque: 32 ± 2 Nm (24 ± 1 ft·lb)

13. AUTOMATIC TRANSMISSION FLUID

M1001002900093

Checking A/T fluid level

1. Drive the vehicle until the A/T fluid temperature rises to the normal temperature [70 – 80°C (158 – 176°F)].

NOTE: The A/T fluid temperature is measured with MUT-II.

NOTE: If it takes some amount of time until the A/T fluid reaches its normal operating temperature [70 – 80°C (158 – 176°F)], check the A/T fluid level by referring to the left diagram.

2. Park the vehicle on a level surface.
3. Move the selector lever through all positions to fill the torque converter and the hydraulic circuits with A/T fluid, and then move the selector lever to the "N" position.
4. After wiping off any dirt around the dipstick, remove the dipstick and check the condition of the A/T fluid.

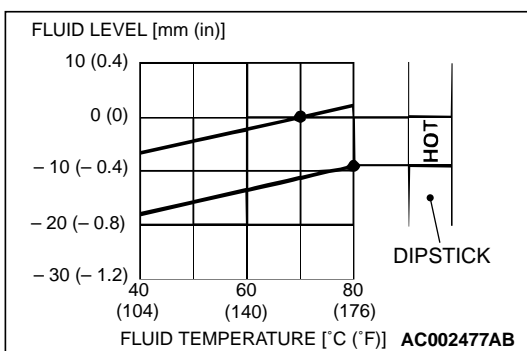

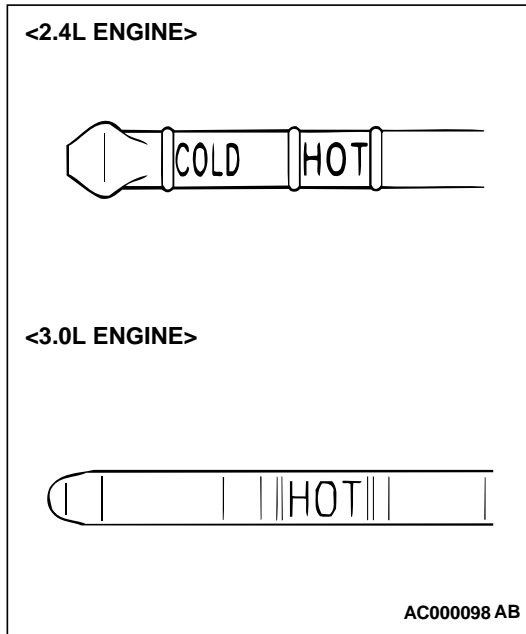

NOTE: If the fluid smells as if it is burnt, it means that the A/T fluid has been contaminated by fine particles from the bushings and friction materials, a transaxle overhaul and flashing the cooler line flushing may be necessary.

5. Check that the A/T fluid level is at the "HOT" mark on the dipstick. If the A/T fluid level is lower than this, pour in more DIAMOND ATF SP-II M or SP-III or equivalent until the level reaches the "HOT" mark.

NOTE: If the A/T fluid level is too low, the oil pump will draw in air along with the A/T fluid, which will cause bubbles to form. This will in turn cause the hydraulic pressure to drop, which will result in late shifting and slipping of the clutches and brakes.

In either case, air bubbles can interfere with normal valve, clutch, and brake operation. Foaming can cause A/T fluid to escape from the transaxle vent, in which case it may be mistaken for a leak.

6. Securely insert the dipstick.

NOTE: The A/T fluid should always be replaced when:

- When trouble shooting the transaxle
- When overhauling the transaxle
- When the oil is noticeably dirty or burnt (vehicle was driven under severe conditions)

Change A/T fluid

If you have a A/T fluid changer, use this changer to replace the A/T fluid. If you do not have a A/T fluid changer, replace the A/T fluid by the following procedure.

1. Disconnect the hose shown in the illustration which connects the transaxle and the oil cooler (inside the radiator). Place a container under the hose to collect the discharge.

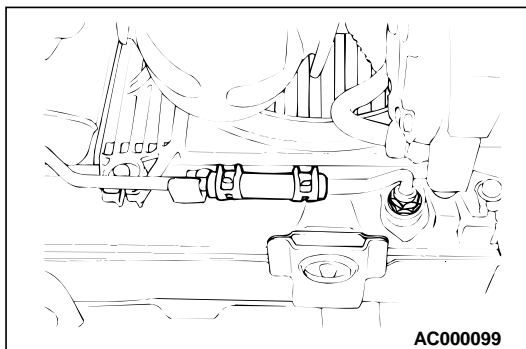

CAUTION

The engine should be stopped within one minute after it is started. If the A/T fluid has all drained out before then, the engine should be stopped at that point. Discharge volume: Approximately 3.5 dm³ (3.7 quarts)

2. Start the engine and let the A/T fluid drain out.

Running conditions: "N" range with engine idling

3. Remove the drain plug from the bottom of the transaxle case to drain the A/T fluid.

Discharge volume: Approximately 2.0 dm³ (2.1 quarts)

4. Install the drain plug with a new gasket, and tighten it to the specified torque.

Tightening torque: 32 ± 2 N·m (24 ± 1 ft·lb)

5. Pour new AT fluid in through the oil filler tube.

Adding volume: Approximately 5.5 dm³ (5.8 quarts)

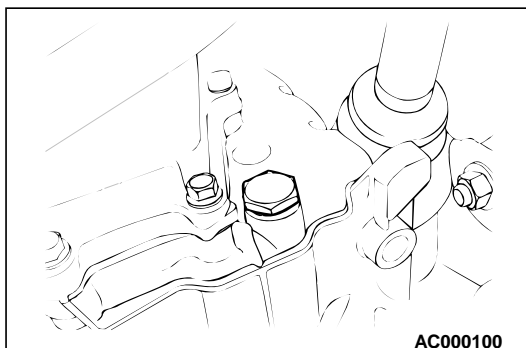

⚠ CAUTION

Stop pouring if the full volume of A/T fluid cannot be poured in.

6. Repeat the procedure in Step 2. (to pump out the rest of the contaminated A/T fluid)

7. Pour the new A/T fluid in through the oil filler tube.

NOTE: Check the A/T fluid for contamination or burnt smell. If A/T fluid is still contaminated or burnt, repeat Steps 6 and 7 before proceeding to Step 8.

8. Reconnect the hose which was disconnected in step 1 above, and firmly replace the dipstick.

9. Start the engine and run it at idle for 1 – 2 minutes.

10. Move the selector lever through all positions, and then move it to the "N" position.

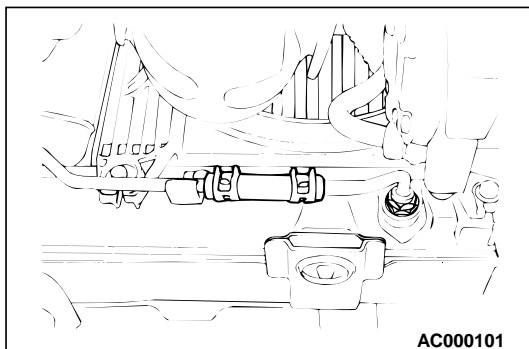

<2.4L ENGINE>

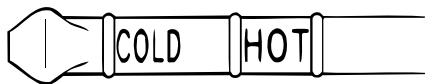

<3.0L ENGINE>



AC000098 AB

11. Check that the A/T fluid level is at the "COLD" mark on the dipstick. If the level is lower than this, pour in more A/T fluid.

12. Drive the vehicle until the A/T fluid temperature rises to the normal temperature [70 – 80°C (158 – 176°F)], and then check the A/T fluid level again. If it takes some amount of time until the A/T fluid reaches its normal operating temperature [70 – 80°C (158 – 176°F)], check the A/T fluid level by referring to the diagram at left. The A/T fluid level must be at the "HOT" mark.

NOTE: The A/T fluid temperature is measured with scan tool (MUT-II). The "COLD" level is for reference only; the "HOT" level should be regarded as the standard level.

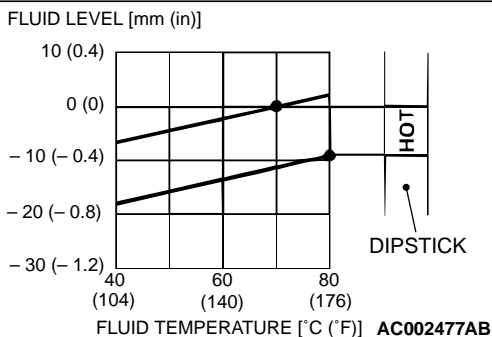

NOTE: If it takes some amount of time until the A/T fluid reaches its normal operating temperature [70 – 80°C (158 - 176°F)], check the A/T fluid level by referring to the left diagram.

13. Firmly insert the dipstick into the oil filler tube.

14. ENGINE COOLANT (CHANGE)

M1001003100090

Check the cooling system parts such as the radiator, heater and oil cooler hoses, thermostat and the connections for leakage and damage.

Changing Coolant

1. Set the temperature control knob to the "HOT" position.
2. Let the engine operate until the engine coolant warms, and then stop the engine.

⚠ CAUTION

When removing the radiator cap, use care to avoid contact with hot coolant or steam. Place a shop towel over the cap and turn the cap counterclockwise a little to let the pressure escape through the vinyl tube. After relieving the steam pressure, remove the cap by slowly turning it counterclockwise.

3. Remove the radiator cap, radiator drain plug and engine drain plug to drain the coolant.
4. Remove the reserve tank and drain the coolant.
5. After completely draining the coolant, reinstall the drain plugs and flush the engine and radiator using a radiator cleaning fluid.
6. After the flushing is completed, completely drain the cleaning fluid and install the radiator and engine drain plugs.
7. By referring to the section on coolant, select an appropriate concentration for safe operation for safe operating temperature within the range of 30 to 60%. Refill the coolant at the selected concentration. A convenient mixture is a 50% water and 50% antifreeze solution [freezing point: -31°C (-32.8°F)].

Recommended antifreeze:

MITSUBISHI GENUINE Part NO.MD970389 or equivalent

Quantity:

<2.4L Engine> 7.0 dm³ (7.4 quarts)

<3.0L Engine> 8.0 dm³ (8.5 quarts)

⚠ CAUTION

Do not use alcohol or methanol anti-freeze or any engine coolants mixed with alcohol or methanol anti-freeze. The use of an improper anti-freeze can cause the corrosion of the aluminum components.

8. Reinstall the radiator cap.
9. Start the engine and let it warm up until the thermostat opens.
10. After repeatedly revving the engine up to 3,000 r/min several times, then stop the engine.
11. Remove the radiator cap after the engine has become cold, and pour in coolant up to the brim. Reinstall the cap.

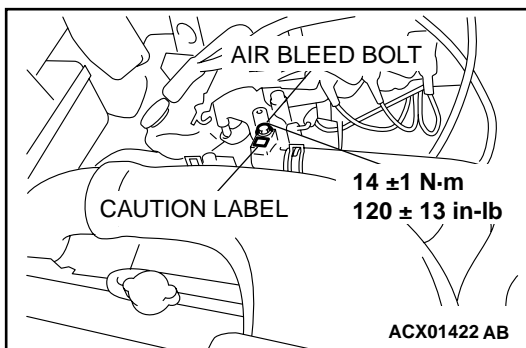
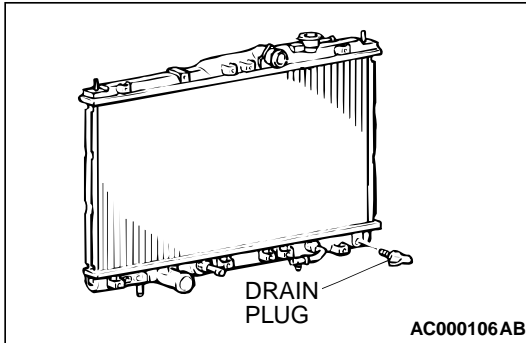

⚠ CAUTION

Do not overfill the reserve tank.

12. Add coolant to the reserve tank between the "FULL" and "LOW" mark if necessary.

15. DISC BRAKE PADS (INSPECT FOR WEAR)

M1001003200097

Check for fluid contamination and wear. Replace the complete set of pads if defective.

Thickness of lining

Minimum limit: 2.0 mm (0.08 inch)

⚠ CAUTION

The pads for the right and left wheels should be replaced at the same time. Never split or intermix brake pad sets. All four pads must be replaced as a complete set.

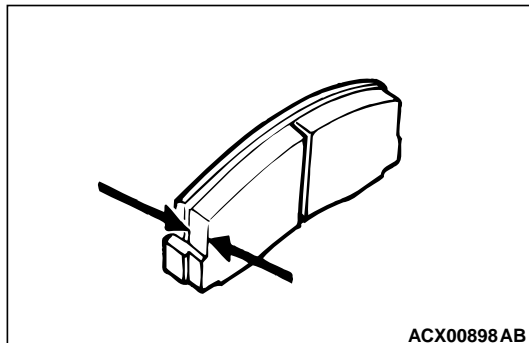

16. REAR DRUM BRAKE LININGS AND REAR WHEEL CYLINDERS (INSPECT FOR WEAR AND LEAKS)

M1001003300083

1. Remove the brake drum and check the thickness of brake shoe lining for wear. Check the automatic brake adjusting system by hand to see if it operates smoothly. Also see if the gears are in proper mesh with each other. To assure smooth operation, apply a very thin coat of multipurpose grease to the friction surface of the adjuster and link shaft.

⚠ CAUTION

The shoes for the right and left wheels should be replaced at the same time. Never split or intermix brake shoe seats. All four shoes must be replaced as a complete set.

2. Inspect the wheel cylinder boot for evidence of a brake fluid leak. Visually check the boot for cuts, tears or heat cracks. (A slight amount of fluid on the boot may not be a leak, but may be preservative fluid used at assembly.) Check the Brake Shoes for Wear.

Thickness of lining

Minimum limit: 1.0 mm (0.04 inch)

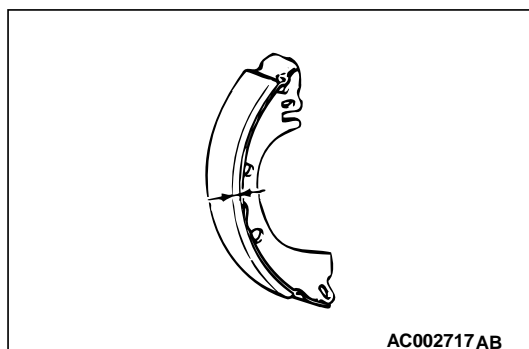

17. BRAKE HOSES (CHECK FOR DETERIORATION OR LEAKS)

M1001003400091

Inspection of brake hoses and tubing should be included in all brake service operations.

The hoses should be checked for:

1. Correct length, severe surface cracking, pulling, scuffing or worn spots. (If the fabric casing of the hoses is exposed by cracks or abrasion in the rubber hose cover, the hoses should be replaced. Eventual deterioration of the hose and possible bursting failure may occur.)
2. Incorrect installation, casing twisting or interference with wheel, tire or chassis.

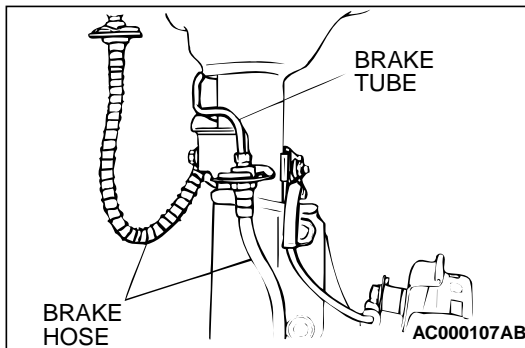
**18. BALL JOINT AND STEERING LINKAGE SEALS (INSPECT FOR GREASE LEAKS AND DAMAGE)**

M1001003500098

1. These components, which are permanently lubricated at the factory, do not require periodic lubrication. Damaged seals and boots should be replaced to prevent leakage or contamination of the grease.
2. Inspect the dust cover and boots for proper sealing, leakage and damage, and replace them if defective.

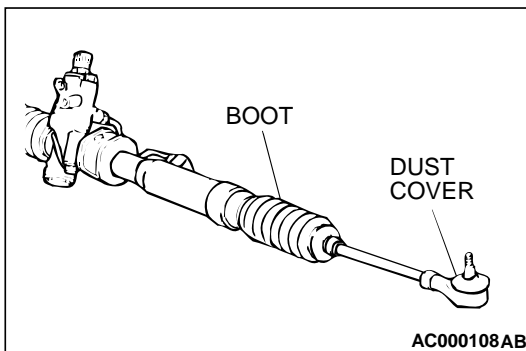
**19. DRIVE SHAFT BOOTS (INSPECT FOR GREASE LEAKS AND DAMAGE)**

M1001003600095

1. These components, which are permanently lubricated at the factory, do not require periodic lubrication. Damaged seals and boots should be replaced to prevent leakage or contamination of the grease.
2. Inspect the dust cover and boots for proper sealing, leakage and damage, and replace them if defective.

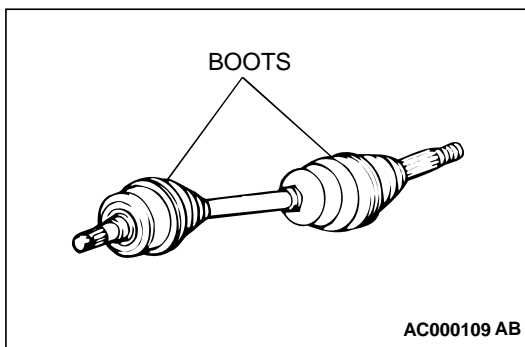

20. SRS AIR BAG (INSPECT FOR SRS SYSTEM)

M1001003700092

The SRS must be inspected by an authorized dealer 10 years after the car manufacture date shown on the certification label located on the left center sill.

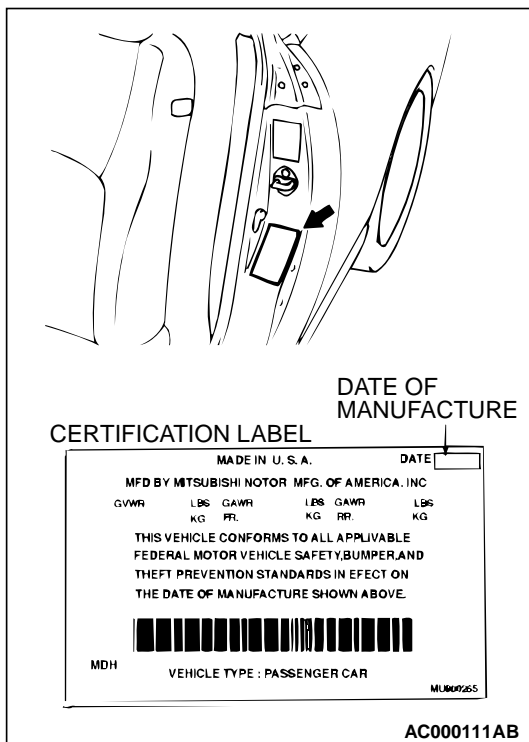

SRS Warning Light Check

Turn the ignition key to the "ON" position. Does the "SRS" warning light illuminate for about seven seconds, and then remain off for at least five seconds after turning OFF? If yes, the SRS system is functioning properly. If no, refer to GROUP 52B, Diagnosis [P.52B-20](#).

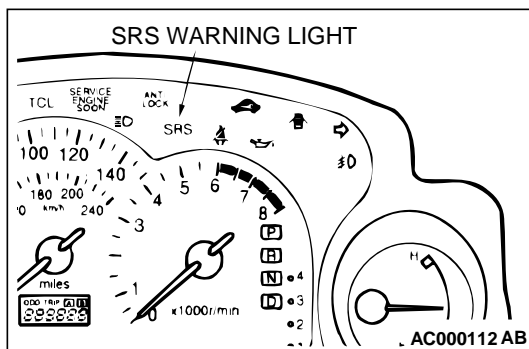

SRS Component Visual Check

⚠ DANGER

Wait at least 60 seconds after disconnecting the battery cable before doing any further work. The SRS system is designed to retain enough voltage to deploy the air bag for a short time even after the battery has been disconnected, so serious injury may result from unintended air bag deployment if work is done on the SRS system immediately after the battery cable is disconnected.

⚠ WARNING

Battery posts, terminals and related accessories contain lead and lead compounds. WASH HANDS AFTER HANDLING.

1. Turn the ignition switch to the "LOCK" (OFF) position, disconnect the negative battery cable and tape the terminal.
2. Remove the floor console assembly. (Refer to GROUP 52A, Floor Console P.52A-9.)
3. Disconnect a connector from the SRS-ECU.

Side Impact Sensors

⚠ WARNING

- If the side impact sensor is not installed securely and correctly, the side air bag may not operate normally.
- If a dent, crack, deformation or rust is detected, replace with a new sensor.

1. Check the side impact sensor and bracket for dents, cracks or deformation.
2. Check the connector for damage, and terminal for deformation.
3. Check that there is no bending or corrosion in the side outer panel (ECLIPSE) or quarter panel (ECLIPSE SPYDER).

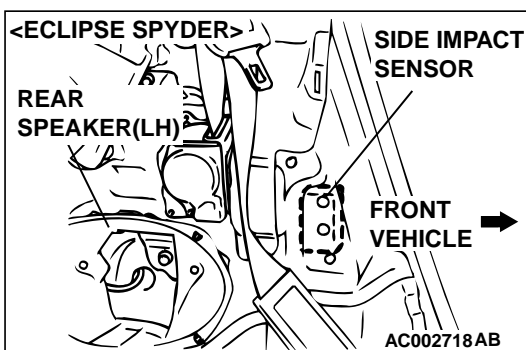
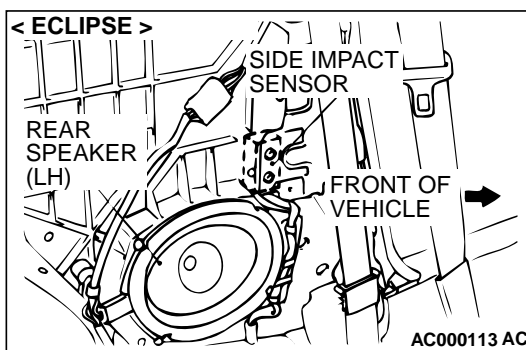
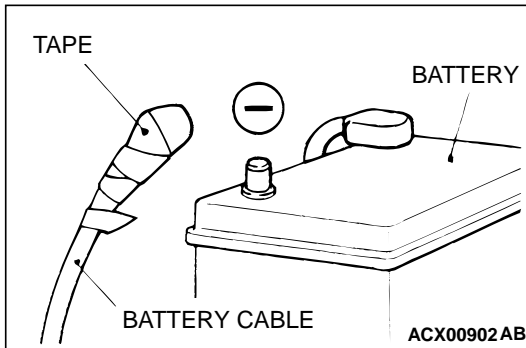

Replace The Side Impact Sensor If It Fails The Visual Check

Refer to GROUP 52B, Side Impact Sensor [P.52B-76](#).

NOTE: The illustration at left shows the left side impact sensor (LH). The position of the side impact sensor (RH) is symmetrical to this.

SRS Air Bag Control Unit (SRS-ECU)

⚠ WARNING

The SRS may not activate if the SRS-ECU (with built-in safing G-sensor and analog G-sensor) is not installed properly, which could result in serious injury or death to the vehicle's driver and passenger.

1. Check the SRS-ECU case and brackets for dents, cracks, deformation or rust.
2. Check the connector for damage, and check the terminals for deformation or rust.

Replace the SRS-ECU if it fails the visual check. (Refer to GROUP 52B, SRS Air bag Control Unit [P.52B-66](#).)

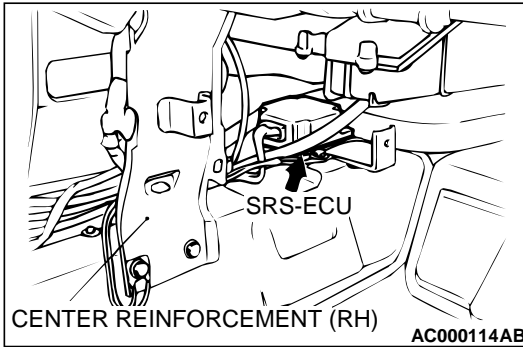

Air Bag Module, Steering Wheel and Clock Spring

⚠ WARNING

The removed air bag module should be stored in a clean, dry place with the pad cover face up.

1. Remove the air bag module, steering wheel and clock spring.
(Refer to GROUP 52B, Air Bag Module and Clock Spring [P.52B-69](#).)
2. Check the pad cover for dents, cracks or deformation.

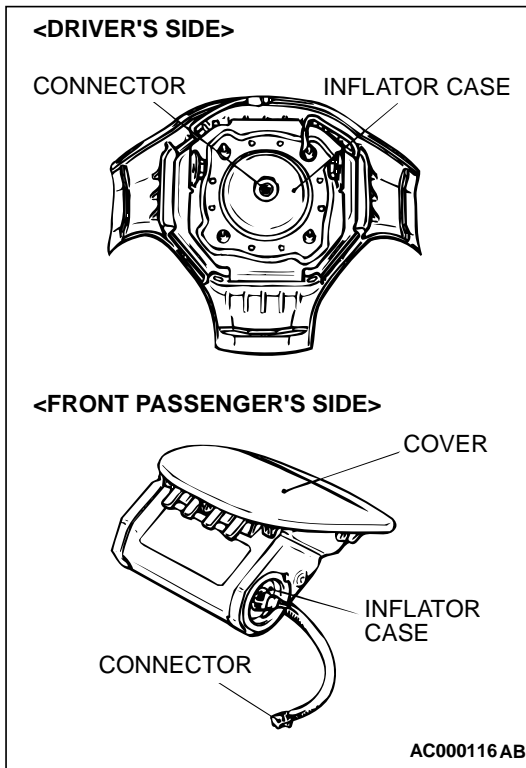

3. Check the connector for damage and deformed terminals, and check the harness for binds.
4. Check the air bag inflator case for dents, cracks or deformation.
5. Check the harness (built into the steering wheel) and connectors for damage, and check the terminals for deformation.

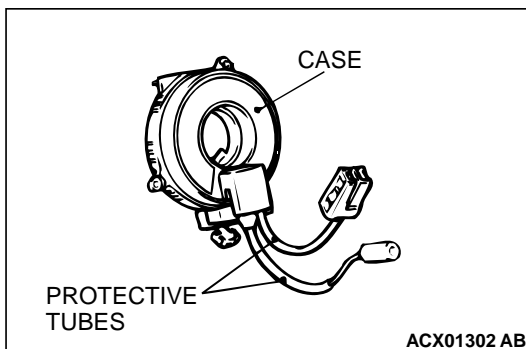

6. Check the clock spring connectors and protective tube for damage, and terminals for deformities.
7. Visually check the case for damage.

⚠ WARNING

If the clock spring's mating mark is not properly aligned, the steering wheel may not completely rotate during a turn, or the flat cable within the clock spring may be severed, obstructing normal operation of the SRS and possibly leading to serious injury to the vehicle's driver and passenger.

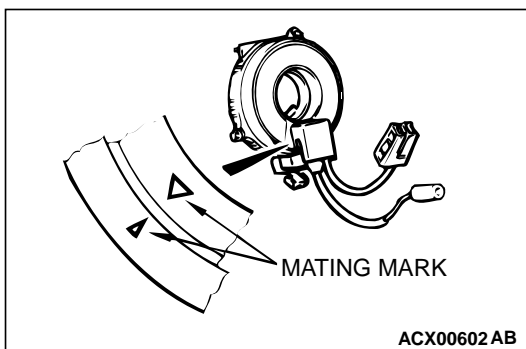

8. Align the mating marks of the clock spring, and after turning the front wheels to the straight-ahead position, install the clock spring to the column switch.

Mating marks alignment

After turning the clock spring fully clockwise, turn it approximately 3 4/5 turns counterclockwise until the mating marks are aligned.

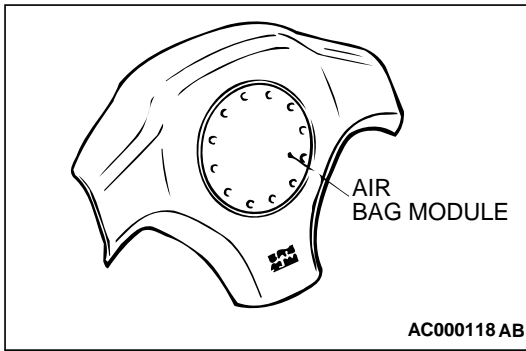

9. Install the steering column covers, steering wheel and air bag module.
10. Check the steering wheel for noise, binds or difficult operation.

⚠ DANGER

The SRS may not activate if any of the above components are not installed properly, which could result in serious injury or death to the vehicle's driver and passenger.

11. Check the steering wheel for excessive free play.
REPLACE ANY VISUALLY INSPECTED PART IF IT FAILS THAT INSPECTION. (Refer to GROUP 52B, Air Bag Module and Clock Spring P.52B-69.)

Wiring Harness

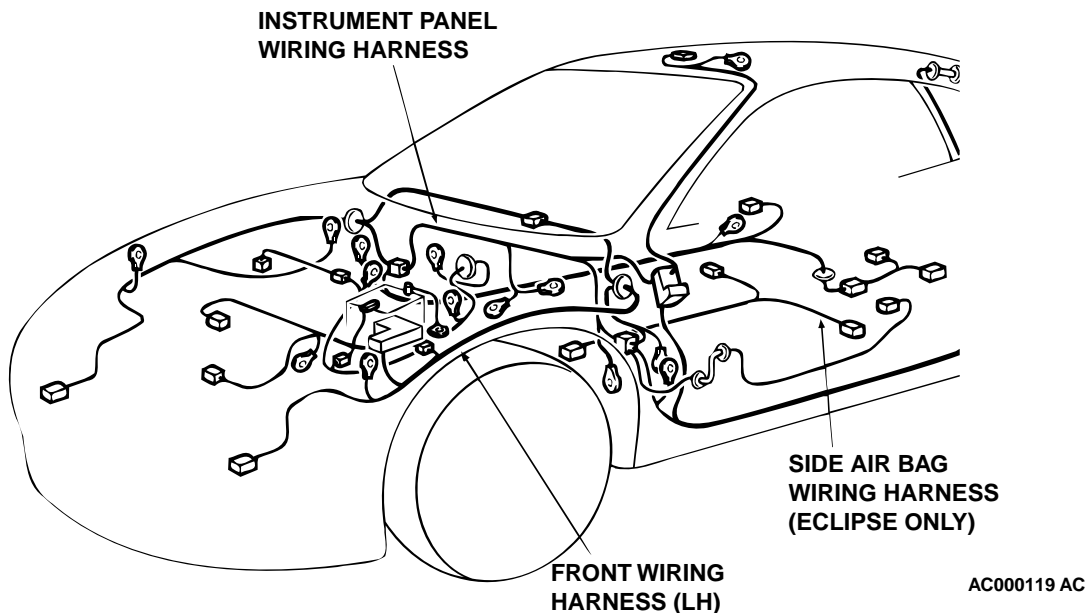

1. Check the connector for poor connection.

⚠ DANGER

The SRS system may not operate if SRS harnesses or connectors are damaged or improperly connected, which could result in serious injury or death to the vehicle's driver and passenger.

2. Check the harness for binds, the connectors for damage, and the terminals for deformation. REPLACE ANY CONNECTORS OR HARNESS THAT FAIL THE VISUAL INSPECTION. (Refer to GROUP 52B, SRS Service Precaution P.52B-69.)

21. EXHAUST SYSTEM (CONNECTION PORTION OF MUFFLER, PIPINGS AND CONVERTER HEAT SHIELDS) (CHECK AND SERVICE AS REQUIRED)

M1001005800073

1. Check for holes and gas leaks due to damage, corrosion, etc.
2. Check the joints and connections for looseness and gas leaks.
3. Check the hanger rubber and brackets for damage.

22. TIRES (ROTATE)

M1001008900080

Rotate tires regularly to equalize tire wear and help extend tire life. Recommended tire rotation is every 7,500 miles (12,000 km) under normal driving conditions and every 6,000 miles (9,600 km) in severe driving conditions.

Timing for the rotation may vary according to vehicle condition, road surface conditions, and individual driver's habits.

When rotating tires, check for uneven wear, damage, and wheel alignment. Abnormal wear is usually caused by incorrect tire pressure, improper wheel alignment, out-of balance wheels, or severe braking.

The first rotation is the most important to achieve more uniform wear for all tires on the vehicle.

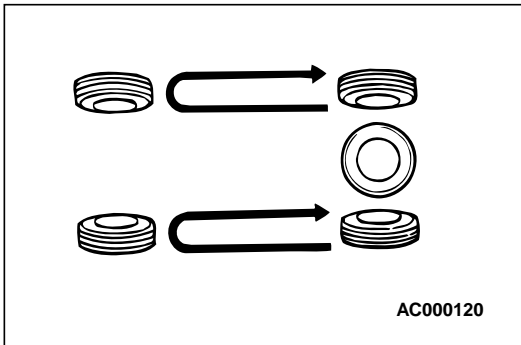

AC000120

23. AIR PURIFIER FILTER (REPLACE)

M1001009000013

1. Remove the glove box inner and outer (Refer to [P.52A-4.](#))
2. Pull the air purifier filter out of the blower assembly.
3. Insert a new air purifier into the glove box inner and outer.

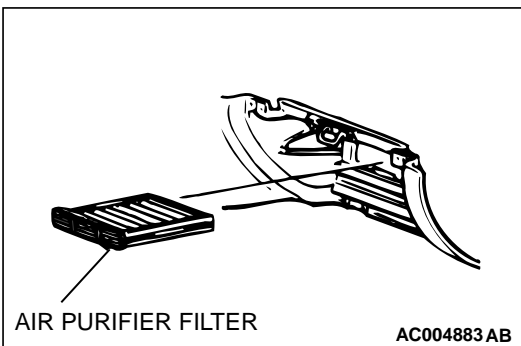

AIR PURIFIER FILTER

AC004883 AB

MAIN SEALANT AND ADHESIVE TABLE

M1001003800107

APPLICATION		3M™ NO.	LOCTITE®/ PERMATEX® NO.
ENGINE AND DRIVETRAIN	Between rocker cover and camshaft bearing cap. Between rocker cover, semicircular packing and cylinder head. Between oil pressure switch and engine.	3M™ AAD Part No. 8660 Ultrapro High Temp. Silicone Gasket or 3M™ AAD Part No. 8679 Black/8678 Black Press-In-Place Silicone gasket strips	Permatex® Ultra Black 598, No.82180
	Between engine coolant temperature switch, engine coolant temperature sensor, thermo valve, thermo switch, joint, engine coolant temperature gauge unit (large-size) and engine	3M™ AAD Part No. 8731 Medium Strength Blue Threadlocker	Loctite®242 Blue Service Tool Removable 24200
	Between oil pan and engine block	3M™ AAD Part No. 8672, 3M™ AAD Part No. 8704 or 3M™ AAD Part No. 8679/ 3M™ AAD Part No. 8678 or	Permatex® Ultra Gray 599, No.82194
WEATHERSTRIPPING FOR GLASS	Between tempered glass, body flanges, and weatherstrip	3M™ AAD Part No. 8509 Auto Bedding and Glazing Compound or 3M™ AAD Part No. 8633 Windo-weld Resealant	-
WEATHERSTRIPPING FOR GLASS	Between laminated glass and weatherstrip	3M™ AAD Part No. 8633	-
INTERIORS	Adhesive of vinyl chloride cloth	3M™ AAD Part No. 8088 General Trim Adhesive or 3M™ AAD Part No. 8064 Vinyl Trim Adhesive	Permatex® Vinyl Repair Kit No.81786
	Adhesion of door weatherstrip	3M™ AAD Part No. 8001 (yellow) or 3M™ AAD Part No. 8008 (black) Super Weatherstrip Adhesive or 3M™ AAD Part No. 8011 Black Weatherstrip Adhesive	Permatex® Super Black Weatherstrip Adhesive No.82, 81850
	Sealing of various grommets and packing	3M™ AAD Part No. 8509 or 3M™ AAD Part No. 8678	-
	Adhesion of headliners and various interior decorative materials	3M™ AAD Part No. 8088 General Trim Adhesive or 3M™ AAD Part No. 8090 Super Trim Adhesive	Permatex® Spray Adhesive No.82019

**GENERAL <BODY AND CHASSIS>
MAIN SEALANT AND ADHESIVE TABLE**

APPLICATION		3M™ NO.	LOCTITE®/ PERMATEX® NO.
BODY SEALANTS	Sealing of sheet metal joints, drip rail, floor, side panels, trunk, front panel, tail gate hinge	3M™ AAD Part No. 8531 Heavy Drip-Check Sealer (gray) or 3M™ AAD Part No. 8302 Ultrapro Autobody Sealant (clear) or 3M™ AAD Part No. 8361 Urethane A/B Sealant (gray or white)	—
	Miscellaneous body sealants (original mounted w/adhesive tape) <ul style="list-style-type: none"> • Waterproof door film • Fender panel • Splash shield • Mud guard • Rear combination lamp 	3M™ AAD Part No. 8633 Windo-weld Resealant	—
	Fuel Tank and Pad	3M™ AAD Part No. 8088 General Trim Adhesive or 3M™ AAD Part No. 8090 Super Trim Adhesive	Permatex® Spray Adhesive No.82019
CHASSIS SEALANT	Sealant of various flange faces and threaded parts. Packing of fuel gauge unit	3M™ AAD Part No. 8730 High Strength Red Thread lock or 3M™ AAD Part No. 8731 Medium Strength Blue Threadlocker	Loctite®272 High Strength and High Temperature 27200
	Sealing of various threaded parts, dust covers. Differential carrier packing, dust covers and ball joint and linkage. Packing and shims of steering box, sealing of rack support cover and top cover of steering box housing, seal of junction face of knuckle arm flange	3M™ AAD Part No. 8672 Ultrapro High Temp.Silicone Gasket or 3M™ AAD Part No. 8679 (black) or 3M™ AAD Part No. 8678 (black) Press-In-Place Silicone gasket strips 3M™ AAD Part No. 8661 or 3M™ AAD Part No. 8663 Super Silicone sealant	Permatex® The Right Stuff No.25223
	Seal of brake shoe hold down pin and wheel cylinder of drum brakes	3M™ AAD Part No. 8633 Windo-weld Resealant	—

**GENERAL <BODY AND CHASSIS>
MAIN SEALANT AND ADHESIVE TABLE**

00-63

APPLICATION		3M™ NO.	LOCTITE®/ PERMATEX®NO.
QUICK FIX ADHESIVE	-	3M™ AAD Part No. 8155 Quick Fix Adhesive	Loctite®Quicktite Super Glue 21309
ANAEROBIC STRONG SEALING AGENT	Fixing of various threads, bolts, screws. Fixing of differential drive gear bolt, Connecting of tilt steering bolt. Fan, pulley, gear Sealing of small gaps and flange faces	3M™ AAD Part No. 8730 High Strength Threadlocker or 3M™ AAD Part No. 8731 Medium Strength ThreadlockerThreadlocker	Loctite®271, High- Strength Threadlocker 27100 or 27200
UNDERCOATING AGENT	-	3M™ AAD Part No. 8883 Rubberized Undercoating Aerosol or 3M™ AAD Part No. 8864 Body Schutz Undercoating (qt)	Permatex® Heavy-Duty Undercoating 81833

TSB Revision

NOTES