

# GROUP 33A

# FRONT SUSPENSION

## CONTENTS

<b>GENERAL DESCRIPTION</b> .....	<b>33A-2</b>		
<b>FRONT SUSPENSION DIAGNOSIS</b> .	<b>33A-3</b>		
INTRODUCTION TO FRONT SUSPENSION DIAGNOSIS .....	33A-3		
FRONT SUSPENSION DIAGNOSIS TROUBLESHOOTING STRATEGY .....	33A-3		
SYMPTOM CHART.....	33A-3		
SYMPTOM PROCEDURES .....	33A-3		
<b>SPECIAL TOOLS</b> .....	<b>33A-5</b>		
<b>ON-VEHICLE SERVICE</b> .....	<b>33A-6</b>		
FRONT WHEEL ALIGNMENT CHECK AND ADJUSTMENT .....	33A-6		
BALL JOINT DUST COVER CHECK .....	33A-8		
<b>STRUT ASSEMBLY</b> .....	<b>33A-9</b>		
REMOVAL AND INSTALLATION .....	33A-9		
INSPECTION .....	33A-9		
		DISASSEMBLY AND ASSEMBLY .....	33A-10
		INSPECTION.....	33A-12
		<b>LOWER ARM</b> .....	<b>33A-13</b>
		REMOVAL AND INSTALLATION .....	33A-13
		INSPECTION.....	33A-14
		BALL JOINT DUST COVER REPLACEMENT .....	33A-15
		LOWER ARM REAR BUSHING REPLACEMENT .....	33A-15
		<b>STABILIZER BAR</b> .....	<b>33A-16</b>
		REMOVAL AND INSTALLATION .....	33A-16
		INSPECTION.....	33A-17
		<b>SPECIFICATIONS</b> .....	<b>33A-17</b>
		FASTENER TIGHTENING SPECIFICATIONS.....	33A-17
		GENERAL SPECIFICATIONS .....	33A-18
		SERVICE SPECIFICATIONS .....	33A-18
		COMPONENT IDENTIFICATION .....	33A-18

## GENERAL DESCRIPTION

M1332000100117

### FRONT SUSPENSION

The front suspension is MacPherson strut type with coil springs and compression rod. Anti-dive geometry ensures excellent driving stability while negative offset geometry provides good braking stability. The offset coil spring ensures optimum riding comfort.

### CONSTRUCTION DIAGRAM

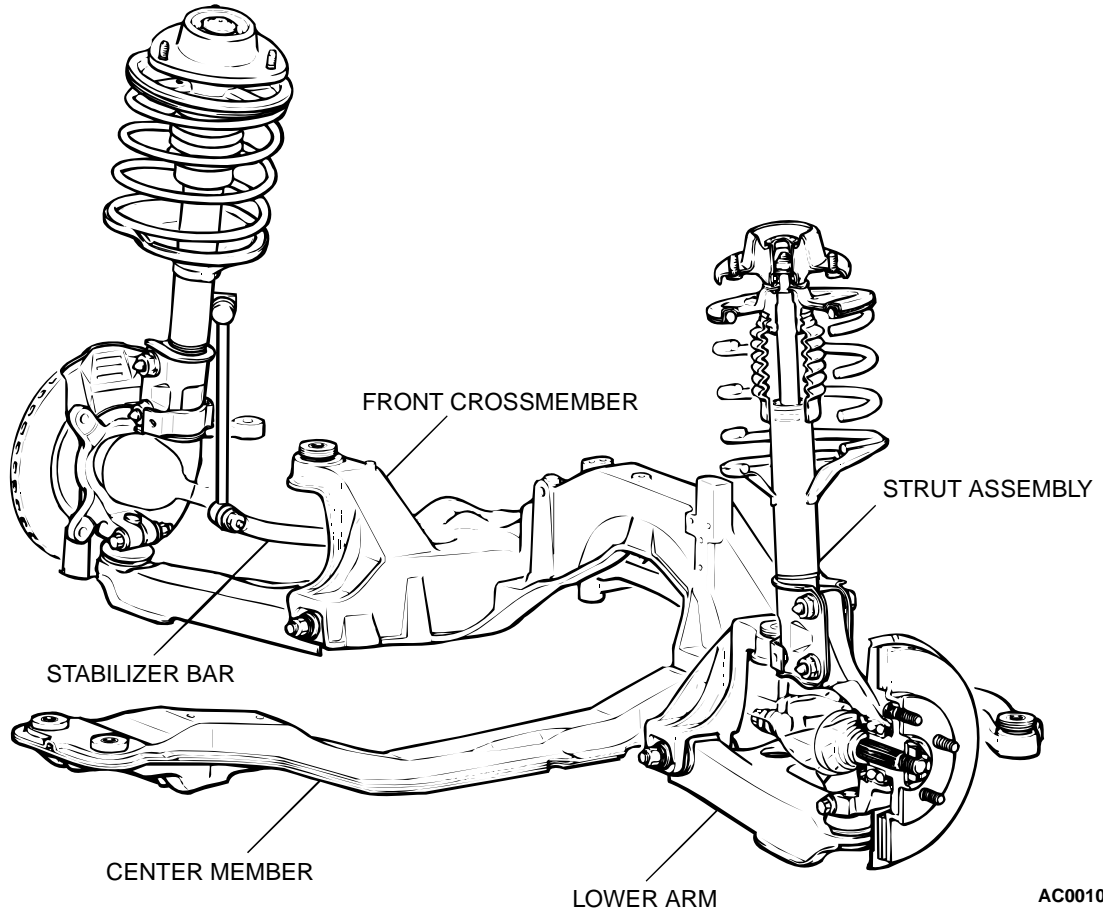

AC001077AB

## FRONT SUSPENSION DIAGNOSIS

### INTRODUCTION TO FRONT SUSPENSION DIAGNOSIS

M1332009000151

If the front suspension is faulty, the vehicle will not run straightforward or noise will occur. Incorrect wheel alignment, malfunction of strut assembly, stabilizer bar, coil spring, or worn or out-of-balance tires can cause these problems.

### FRONT SUSPENSION DIAGNOSIS TROUBLESHOOTING STRATEGY

M1332009100147

Use these steps to plan your diagnostic strategy. If you follow them carefully, you will be sure that you have exhausted most of the possible ways to find a front suspension fault.

1. Gather information from the customer.

2. Verify that the condition described by the customer exists.
3. Find and repair the malfunction by following the Symptom Chart and Symptom Procedures.
4. Verify malfunction is eliminated.

### SYMPTOM CHART

M1332009400159

SYMPTOMS	INSPECTION PROCEDURE	REFERENCE PAGE
Steering wheel is heavy, vibrates or pulls to one side	1	P.33A-3
Excessive body rolling	2	P.33A-4
Poor riding	3	P.33A-4
Unequal ride height	4	P.33A-4
Noise	5	P.33A-5

### SYMPTOM PROCEDURES

#### INSPECTION PROCEDURE 1: Steering Wheel is Heavy, Vibrates or Pulls to One Side

##### DIAGNOSIS

##### STEP 1. Check the tires.

Refer to GROUP 31, Diagnosis P.31-2.

**Q: Are the tires at normal condition?**

- YES :** Replace as necessary, then go to Step 2.  
**NO :** If out of balance, balance as necessary. If excessively worn, replace as necessary and go to Step5.

##### STEP2. Check the wheel alignment.

**Q: Is the wheel alignment correct?**

- YES :** Go to Step 3.  
**NO :** Adjust it, then go to Step 5.

##### STEP 3. Check the ball joint.

**Q: Is the ball joint in good condition?**

- YES :** Go to Step 4.  
**NO :** Replace it, then go to Step 5.

##### STEP4. Check the coil spring.

**Q: Is the coil spring in good condition?**

- YES :** Go to Step 5.  
**NO :** Replace it, then go to Step 5.

##### STEP 5. Check symptoms.

**Q: Is the malfunction eliminated?**

- YES :** This diagnosis is complete.  
**NO :** Return to Step 1.

**INSPECTION PROCEDURE 2: Excessive Body Rolling****DIAGNOSIS****STEP 1. Check for broken or deteriorated stabilizer bar.****Q: Is the stabilizer bar in good condition?****YES :** Go to Step 2.**NO :** Replace it, then go to Step 3.**STEP 2. Check for strut assembly damage.****Q: Is the strut assembly in good condition?****YES :** Go to Step 3.**NO :** Replace it, then go to Step 3.**STEP 3. Check symptoms.****Q: Is the malfunction eliminated?****YES :** This diagnosis is complete.**NO :** Return to Step 1.**INSPECTION PROCEDURE 3: Poor Riding****DIAGNOSIS****STEP 1. Check for improper tire inflation pressure.**Refer to GROUP 31, On-vehicle Service – Tire Inflation Pressure Check [P.31-7](#).**Q: Is the tire inflation correct?****YES :** Go to Step 2.**NO :** Adjust it, then go to Step 4.**STEP 2. Check for broken or deteriorated coil spring(s).****Q: Is the coil spring(s) broken or deteriorated?****YES :** Replace it, then go to Step 4.**NO :** Go to Step 3.**STEP 3. Check for strut assembly damage.****Q: Is the strut assembly damaged?****YES :** Replace it, then go to Step 4.**STEP 4. Check symptoms.****Q: Is the malfunction eliminated?****YES :** This diagnosis is complete.**NO :** Return to Step 1.**INSPECTION PROCEDURE 4: Unequal Ride Height****DIAGNOSIS****STEP 1. Check for broken or deteriorated coil spring(s).****Q: Is the coil spring(s) broken or deteriorated?****YES :** Replace it, then go to Step 2.**NO :** Go to Step 2.**STEP 2. Check symptoms.****Q: Is the malfunction eliminated?****YES :** This diagnosis is complete.**NO :** Return to Step 1.

**INSPECTION PROCEDURE 5: Noise**

**DIAGNOSIS**

**STEP 1. Check for lack of lubrication.**

**Q: Is lubrication inadequate?**

**YES :** Lubricate it, then go to Step 5.

**NO :** Go to Step 2.

**STEP 2. Check the tightened parts for looseness as well as the bushings for wear.**

**Q: Are the tightened parts and bushings in good condition?**

**YES :** Go to Step 3.

**NO :** Replace it, then go to Step 5.

**STEP 3. Check for broken coil spring.**

**Q: Is the coil spring broken?**

**YES :** Replace it, then go to Step 5.

**NO :** Go to Step 4.

**STEP 4. Check for strut assembly damage.**

**Q: Is the strut assembly damaged?**

**YES :** Replace it, then go to Step 5.

**NO :** Go to Step 5.

**STEP 5. Check symptoms.**



**Q: Is the malfunction eliminated?**

**YES :** This diagnosis is complete.

**NO :** Return to Step 1.

**SPECIAL TOOLS**

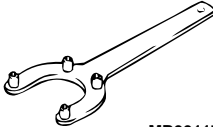
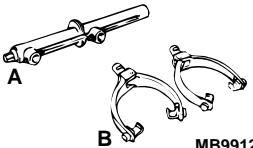
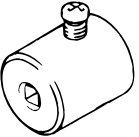
M1332000600145

TOOL	TOOL NUMBER AND NAME	SUPERSESSION	APPLICATION
 MB991004	MB991004 Wheel alignment gauge attachment	MB991004-01 or General service tool	Wheel alignment measurement
 MB991176	MB991176 Spring seat holder	General service tool	Strut disassembly and assembly
 A B MB991237	<ul style="list-style-type: none"> <li>A: MB991237 Spring compressor body</li> <li>B: MB991238 Arm set</li> </ul>	MIT221369	Front coil spring compression
 MB991006	MB991006 Preload socket	MB990228-01	Lower arm ball joint breakaway torque check
 MB990799	MB990799 Ball joint dust cover installer	MB990799-01	Lower arm ball joint dust cover installation

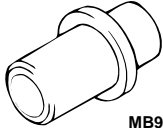
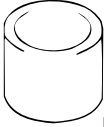
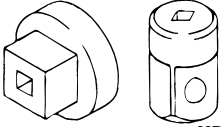
TOOL	TOOL NUMBER AND NAME	SUPERSESSION	APPLICATION
 MB991007	MB991007 Bearing installer	Tool not available	Press-fitting of lower arm ball joint dust cover
 MB991446	MB991446 Bushing remover and installer spacer	Tool not available	Press-fitting of lower arm bushing
 MB990326	MB990326 Preload socket	General service tool	Stabilizer link ball joint breakaway torque measurement

## ON-VEHICLE SERVICE

### FRONT WHEEL ALIGNMENT CHECK AND ADJUSTMENT

M1331000900228

#### Required Special Tool:

- MB991004: Wheel Alignment Gauge Attachment.

Measure wheel alignment with alignment equipment on a level surface. The front suspension, steering system, and wheels should be serviced to normal condition before measuring wheel alignment.

#### TOE-IN

**Standard value: 0 ± 3 mm (0 ± 0.12 inch)**

*NOTE: If the toe-in is not within the standard value, adjust the toe-in by undoing the clips and turning the left and right tie rod turnbuckles by the same amount (in opposite directions).*

*NOTE: The toe will move out as the left turnbuckle is turned toward the front of the vehicle and the right turnbuckle is turned toward the rear of the vehicle.*

*For each one turn of the left and right tie rods, the toe-in will be adjusted by approximately 1°05' (per wheel).*

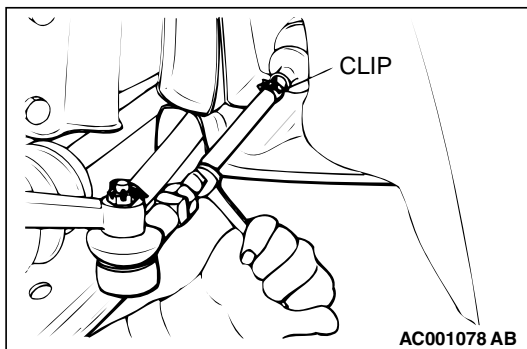

**STEERING ANGLE**

Use a turning radius gauge to check that the steering angle is at the standard value.

**Standard value:**

ITEM	2.4L ENGINE	3.0L ENGINE
Inner wheel	36°12' ± 2°00'	31°00' ± 2°00'
Outer wheel (reference)	30°24'	27°00'

**CAMBER AND CASTER**

**Standard value:**

**Camber 0° 00' ± 30' (Left/right deviation within 30')**

**Caster 3° 00' ± 30' (Left/right deviation within 30')**

*NOTE: Caster is preset at the factory and cannot be adjusted.*

**⚠ CAUTION**

**Never subject the wheel bearings to the vehicle load when the drive shaft nuts are loosened.**

*NOTE: For vehicles with aluminum type wheels, attach the camber/caster/kingpin gauge to the driveshaft by using special tool MB991004. Tighten special tool MB991004 to the same torque 226 ± 29 N·m (167 ± 21 ft-lb) as the driveshaft nut.*

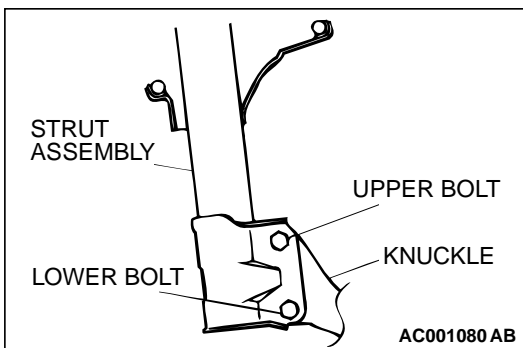
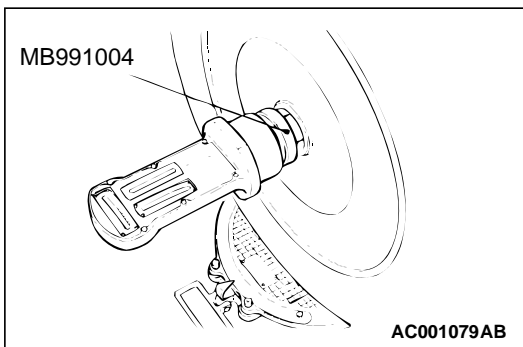

If the camber is outside of the standard value, perform the following adjustment procedures.

1. Estimate how much additional camber adjustment is required. Using the table below, select the camber adjusting bolt, and then replace the knuckle and strut assembly connection bolts (upper bolt, lower bolt) with the selected bolts.

BOLT DIAMETER mm (in)		CAMBER ADJUSTING VALUE					
		0°15'	0°30'	0°45'	1°00'	1°15'	1°30'
Upper bolt	16.0 (0.63)	•	•				
	14.9 (0.59)			•	•		
	14.1 (0.56)					•	
	13.6 (0.54)						•
Lower bolt	16.0 (0.63)	•					
	14.9 (0.59)		•	•			
	14.1 (0.56)				•	•	
	13.6 (0.54)						•

*NOTE: If the camber adjusting value that is required is greater than 1° 30', check for bent or damaged parts and replace as necessary.*

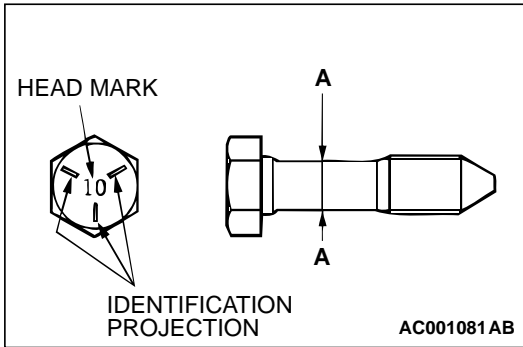

BOLT IDENTIFICATION		
DIAMETER A mm (in)	NUMBER OF IDENTIFICATION PROJECTION	
Set bolt	16.0 (0.63)	0
Adjusting bolt	14.9 (0.59)	1
	14.1 (0.59)	2
	13.6 (0.54)	3

*NOTE: Set bolt is the bolt installed at factory. "10" embossed on bolt head is head mark.*

2. Tighten the nuts temporarily, and then pull or push the front axle to adjust the camber.

*NOTE: Pulling the upper side of the front axle to the outside of the vehicle will increase the camber. Pushing it to the inside of the vehicle will decrease the camber.*

3. Tighten the nuts to 300 ± 24 N-m (221 ± 18 ft-lb).
4. Recheck the camber.

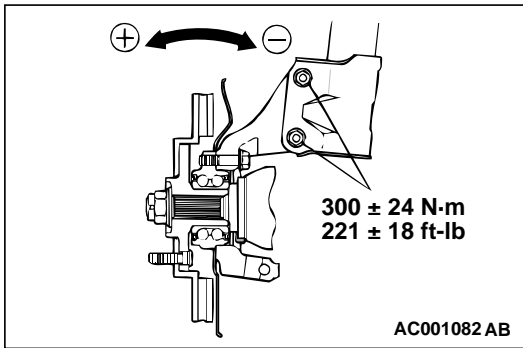

### BALL JOINT DUST COVER CHECK

M1332008600172

1. Press the dust cover with your finger to check that there are no cracks or damage in the dust cover.
2. If the dust cover is cracked or damaged, replace the lower arm assembly or stabilizer link.

*NOTE: If the dust cover is cracked or damaged, it is possible that there may also be damage to the ball joint.*



# STRUT ASSEMBLY

## REMOVAL AND INSTALLATION

M1332001100132

### CAUTION

For vehicles with ABS, be careful when handling the pole piece at the tip of the speed sensor so as not to damage it by striking against other parts.

#### Post-installation Operation

- Check the Dust Cover for Cracks or Damage by Pushing it with Your Finger.
- Front Wheel Alignment Adjustment (Refer to P.33A-6.)

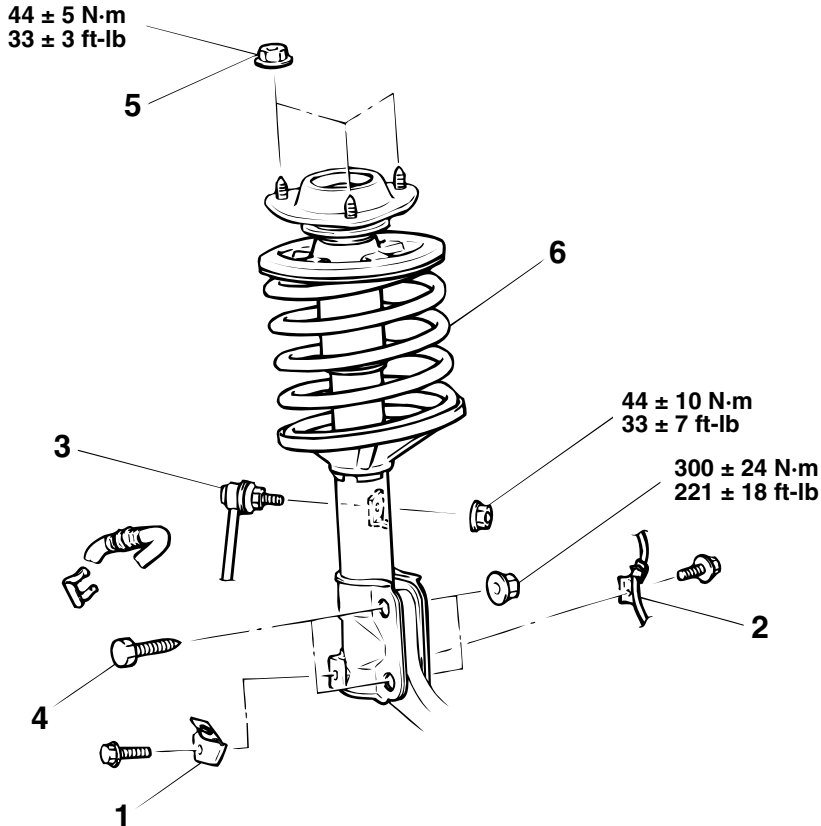

AC001083AB

#### REMOVAL STEPS

- STRUT TOWER BAR <ECLIPSE SPYDER> (REFER TO GROUP 42, <<A>> STRUT TOWER BAR P.42-11.)
1. BRAKE HOSE CLAMP
  2. FRONT SPEED SENSOR HARNESS CLAMP <VEHICLES WITH ABS>

#### REMOVAL STEPS (Continued)

3. STABILIZER LINK
4. BOLTS
5. NUT
6. STRUT ASSEMBLY

## REMOVAL SERVICE POINT

### <<A>> BOLTS REMOVAL

1. Suspend the lower arm from the vehicle with wire.
2. Remove the strut and knuckle connection.

## INSPECTION

- Check for oil leaks from the strut assembly.
- Check the strut assembly for damage or deformation.

M1332001200139

DISASSEMBLY AND ASSEMBLY

M1332001300136

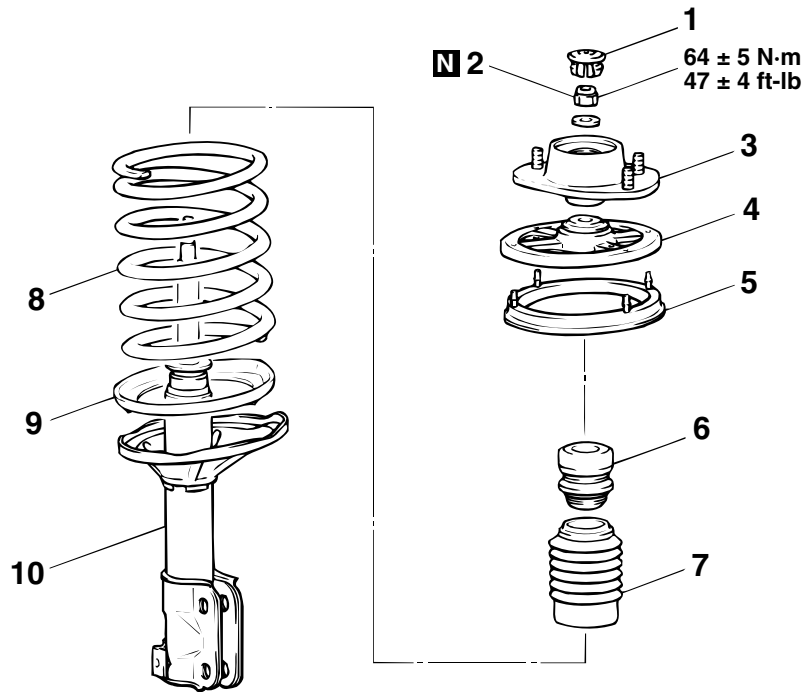

AC001084 AD

**DISASSEMBLY STEPS**

- <<A>> >>A<<
1. DUST COVER
  2. JAM NUT
  3. STRUT INSULATOR
  4. SPRING SEAT, UPPER
  5. SPRING PAD, UPPER
  6. BUMP RUBBER
  7. DUST COVER
  8. COIL SPRING

**DISASSEMBLY STEPS (Continued)**

- <<B>>
9. SPRING PAD, LOWER
  10. STRUT ASSEMBLY

**Required Special Tools:**

- MB991176: Special Spanner
- MB991237: Spring Compressor
- MB991238: Arm Set

**DISASSEMBLY SERVICE POINTS**

<<A>> JAM NUT REMOVAL

**CAUTION**

- To hold the coil spring securely, install special tools MB991237 and MB991238 evenly as shown (parallel with each other).
- Do not use an impact wrench to tighten the bolt of special tool MB991237, otherwise the special tool will break.

1. Use special tools MB991237 and MB991238 to compress the coil spring.

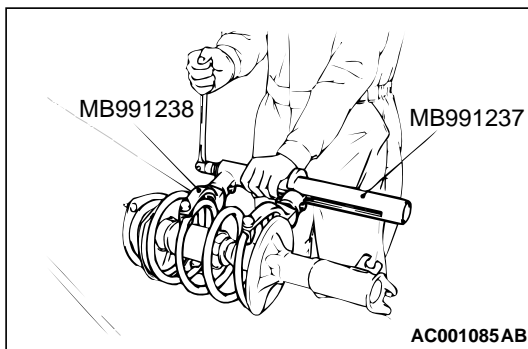

**⚠ WARNING**

**Do not use an impact wrench to remove the jam nut. Vibration of the impact wrench will cause special tools MB991237 and MB991238 to slip and cause bodily harm.**

2. Use special tool MB991176 to secure the strut, and then remove the jam nut.

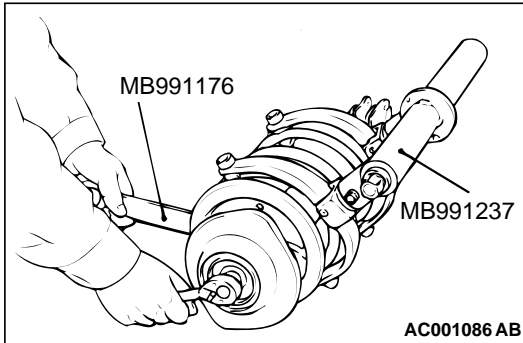

**<<B>> STRUT ASSEMBLY REMOVAL**

**⚠ WARNING**

**Wear goggles when drilling to protect your eyes from flying metal debris.**

The gas must be discharged from the strut assembly before discarding it. Place the assembly horizontally with its piston rod extended. Then drill a hole of approximately 3 mm (0.1 inch) in diameter at the location shown in the illustration and discharge the gas.

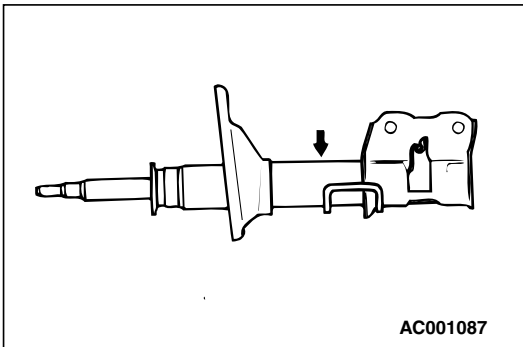

**ASSEMBLY SERVICE POINT**

**>>A<< JAM NUT INSTALLATION**

**⚠ CAUTION**

**Do not use an impact wrench to tighten the bolt of special tool MB991237, otherwise the special tool will break.**

1. With the coil spring held compressed by special tools MB991237 and MB991238, temporarily tighten the jam nut.

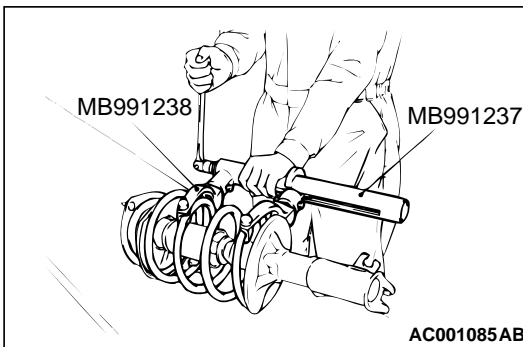

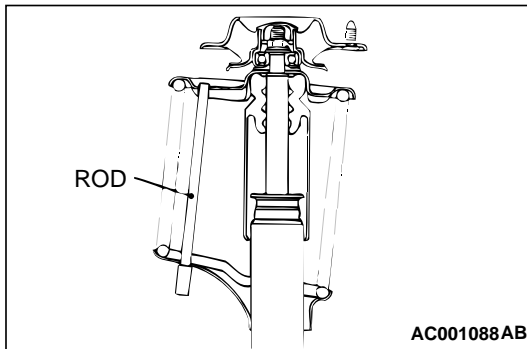

2. Using a rod as shown, line up the holes in the strut assembly spring lower seat with the hole in the spring upper seat.
3. Align both ends of the coil spring with the grooves in spring seat, and then loosen special tools MB991237 and MB991238.

**⚠ CAUTION**

**Do not use an impact wrench to tighten the jam nut, otherwise the jam nut will not be tightened securely.**

4. Using special tool MB991176, tighten the jam nut to  $64 \pm 5$  N·m ( $47 \pm 4$  ft-lb).

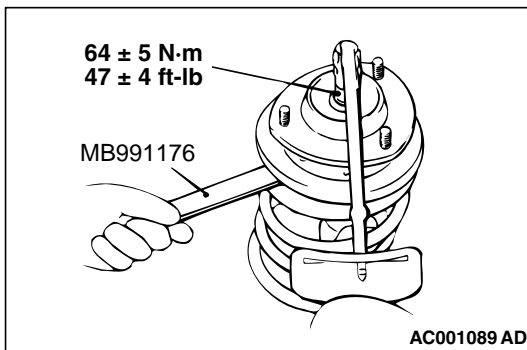
**INSPECTION**

M1332001400092

- Check the bearing for wear or rust.
- Check the rubber parts for damage or deterioration.
- Check the spring for deformation, deterioration or damage.
- Check the shock absorber for deformation.

# LOWER ARM

## REMOVAL AND INSTALLATION

M1332001600148

**⚠ CAUTION**

\*: Indicates parts which should be temporarily tightened, and then fully tightened with the vehicle on the ground in an unladen condition.

**Post-installation Operation**

- Check the Dust Cover for Cracks or Damage by Pushing it with Your Finger.
- Wheel Alignment Check and Adjustment (Refer to P.33A-6.)

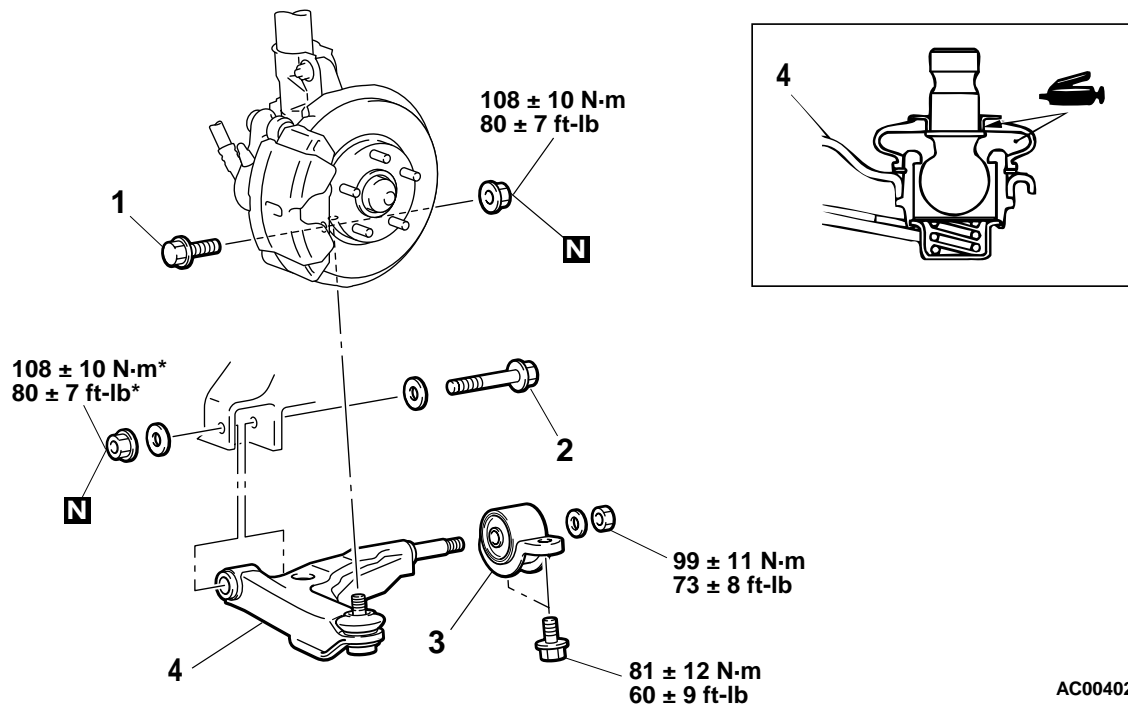

**REMOVAL STEPS**

1. LOWER ARM AND KNUCKLE CONNECTION
2. LOWER ARM MOUNTING BOLT
- >>A<< 3. LOWER ARM CLAMP
4. LOWER ARM

**Required Special Tools:**

- MB990799: Ball Joint Remover and Installer
- MB991006: Preload Socket
- MB991007: Bearing Installer
- MB991446: Bushing Remover and Installer Spacer

## INSTALLATION SERVICE POINT

## &gt;&gt;A&lt;&lt; LOWER ARM CLAMP INSTALLATION

1. The arrow mark on the clamp should point as shown.

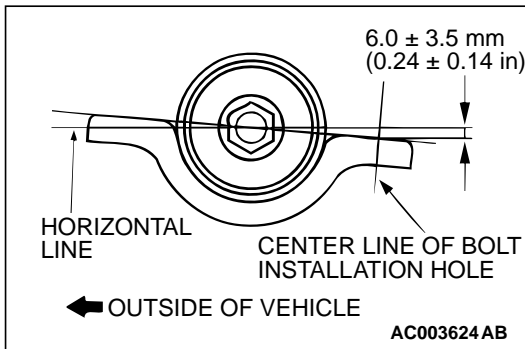
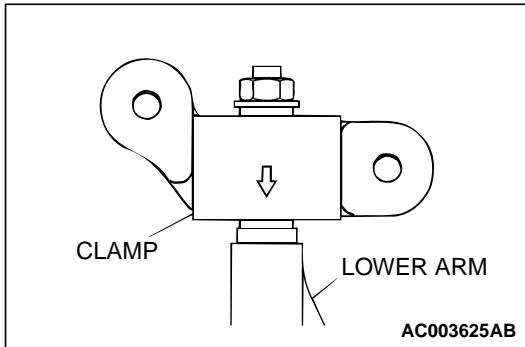

2. Install the clamp into the shaft at the angle shown in the illustration.

## INSPECTION

M1332001700145

- Check the bushing for wear and deterioration.
- Check the lower arm for bend or breakage.
- Check the lower arm clamp for deterioration or damage.
- Check all bolts for condition and straightness.

## BALL JOINT BREAKAWAY TORQUE CHECK

1. After shaking the ball joint stud several times, use special tool MB991006 to measure the breakaway torque of the ball joint.

**Standard value: 2.5 – 6.1 N·m (22 – 54 in-lb)**

2. If the measured value exceeds the standard value, replace the lower arm.
3. If the measured value is lower than the standard value, verify that the ball joint turns smoothly without excessive play. If so, the ball joint is reusable.

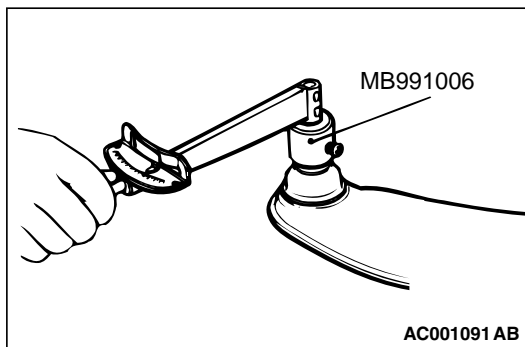

## LOWER ARM BALL JOINT DUST COVER CHECK

1. Check the dust cover for cracks or damage by pushing it with your finger.
2. If the dust cover is cracked or damaged, replace the lower arm.

*NOTE: Cracks or damage to the dust cover may cause damage to the ball joint. When it is damaged during service work, replace the dust cover.*

**BALL JOINT DUST COVER REPLACEMENT**

M1332008200174

If the dust cover is damaged accidentally during service work, replace the dust cover as follows:

1. Remove the dust cover.
2. Apply multipurpose grease to the lip and inside of the dust cover.
3. Using special tool MB990799, drive in the dust cover until it is fully seated.

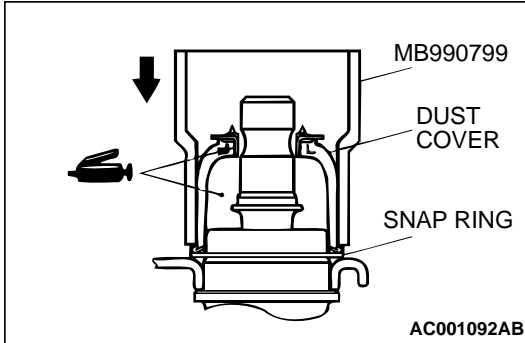

4. Using special tool MB991007, drive in the dust cover plate until it contacts the projection of the ball joint.
5. Check the dust cover for cracks or damage by pushing it with your finger.

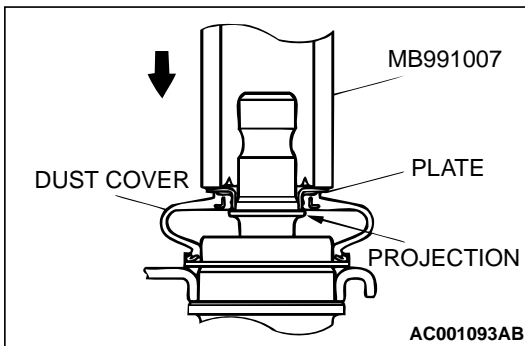

**LOWER ARM REAR BUSHING REPLACEMENT**

M1332008100218

1. Position the lower arm bushing so that its arrow mark points the shown direction.

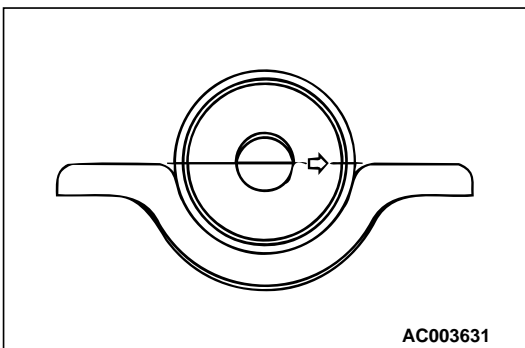

2. Use the special tool MB991446 to press in the bushing to the shown dimension.

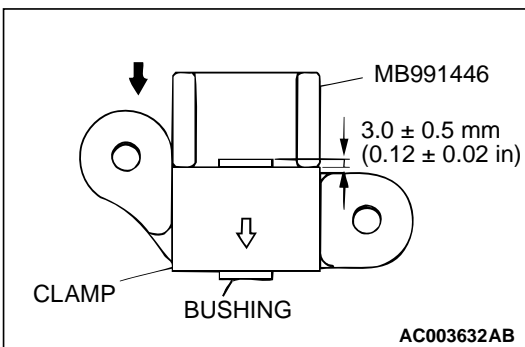

# STABILIZER BAR

## REMOVAL AND INSTALLATION

M1332004000134

<p><b>Pre-removal Operation</b></p> <ul style="list-style-type: none"> <li>• Front Exhaust Pipe Removal &lt;2.4L ENGINE&gt; (Refer to GROUP 15, Exhaust Pipe and Main Muffler P.15-21.)</li> <li>• Centermember Removal &lt;2.4L ENGINE&gt; (Refer to GROUP 32, Engine Roll Stopper, Centermember P.32-8.)</li> <li>• Stay Removal &lt;2.4L ENGINE&gt; (Refer to GROUP 32, Crossmember P.32-10.)</li> <li>• Lower Arm Removal (Refer to P.33A-13.)</li> </ul>	<p><b>Post-installation Operation</b></p> <ul style="list-style-type: none"> <li>• Check the Dust Cover for Cracks or Damage by Pushing it with Your Finger.</li> <li>• Lower Arm Installation (Refer to P.33A-13.)</li> <li>• Stay Installation &lt;2.4L ENGINE&gt; (Refer to GROUP 32, Crossmember P.32-10.)</li> <li>• Centermember Installation &lt;2.4L ENGINE&gt; (Refer to GROUP 32, Engine Roll Stopper, Centermember P.32-8.)</li> <li>• Front Exhaust Pipe Installation &lt;2.4L ENGINE&gt; (Refer to GROUP 15, Exhaust Pipe and Main Muffler P.15-22.)</li> </ul>
---	--

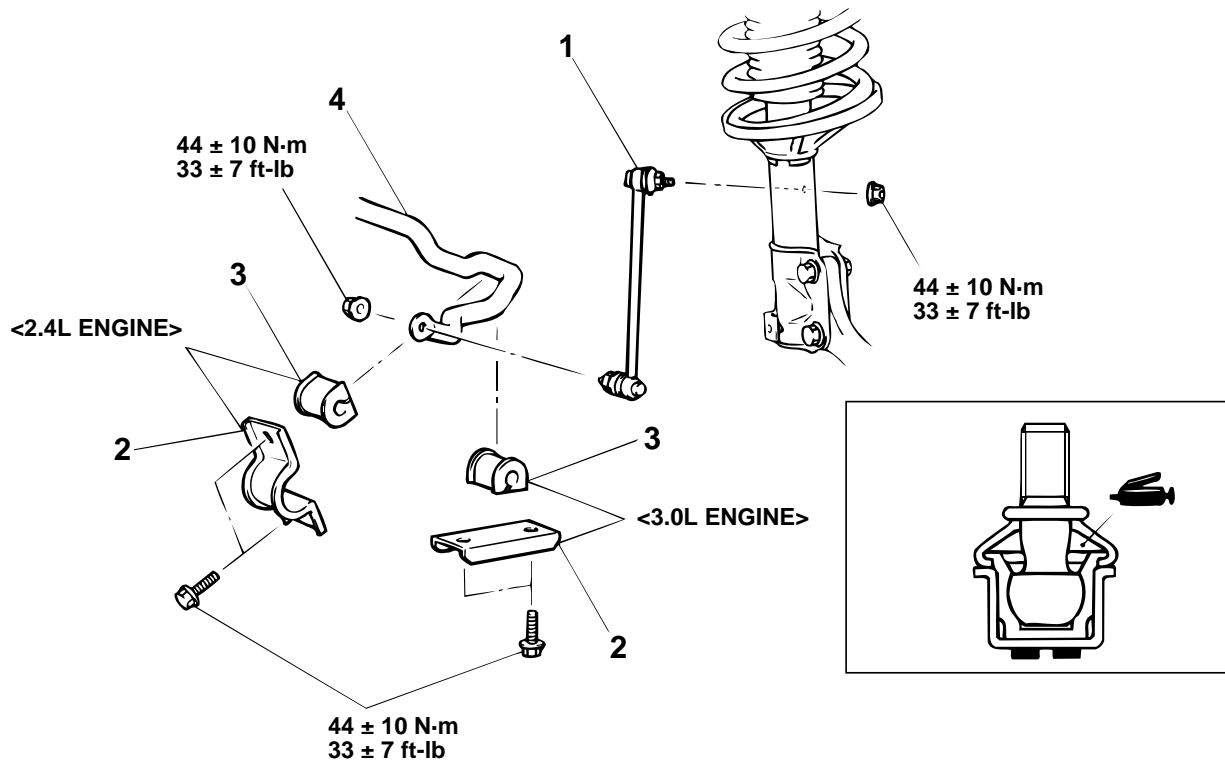

AC003543AC

**REMOVAL STEPS**

- 1. STABILIZER LINK
- >>A<< 2. STABILIZER BRACKET
- >>A<< 3. BUSHING
- <<A>> >>A<< 4. STABILIZER BAR

**Required Special Tool:**

- MB990326: Preload Wrench

**REMOVAL SERVICE POINT**

**<<A>> STABILIZER BAR REMOVAL <3.0L ENGINE>**

Turn the steering wheel to the right to remove the left end of the stabilizer bar.



## INSTALLATION SERVICE POINT

### >>A<< STABILIZER BAR/BUSHING/STABILIZER BAR BRACKET INSTALLATION

Position the stabilizer bar so that the left side identification mark is at the shown position, and tighten the stabilizer bar bracket mounting bolt.

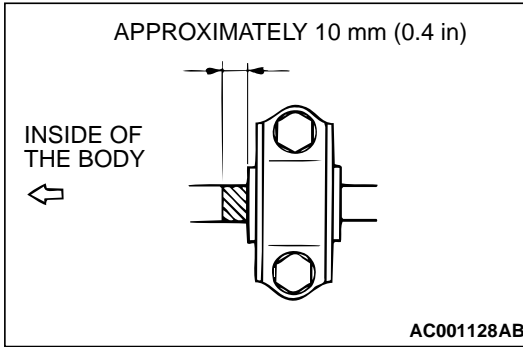

## INSPECTION

M1332002000138

- Check the bushing for wear and deterioration.
- Check the stabilizer bar for deterioration or damage.
- Check all bolts for condition and straightness.

### STABILIZER LINK BALL JOINT BREAKAWAY TORQUE CHECK

1. After shaking the ball joint stud several times, install the nut to the stud and use special tool MB990326 to measure the breakaway torque of the ball joint.

**Standard value: 3.4 – 9.0 N·m (30 – 80 in-lb)**

2. If the measured value exceeds the standard value, replace the stabilizer link.
3. If the measured value is lower than the standard value, verify that the ball joint turns smoothly without excessive play. If so, the ball joint is reusable.

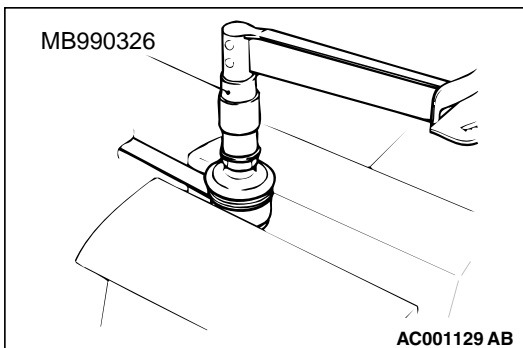

### STABILIZER LINK BALL JOINT DUST COVER CHECK

1. Check the dust cover for cracks or damage by pushing it with your finger.
2. If the dust cover is cracked or damaged, replace the stabilizer link.

## SPECIFICATIONS

### FASTENER TIGHTENING SPECIFICATIONS

M1332008500108

ITEMS	SPECIFICATIONS
<b>Lower arm assembly</b>	
Lower arm clamp bolt	81 ± 12 N·m (60 ± 9 ft-lb)
Lower arm to clamp connection nut	99 ± 11 N·m (73 ± 8 ft-lb)
Lower arm to crossmember connection nut	108 ± 10 N·m (80 ± 7 ft-lb)
Lower arm to knuckle connection nut	108 ± 10 N·m (80 ± 7 ft-lb)

ITEMS	SPECIFICATIONS
<b>Stabilizer bar</b>	
Stabilizer bracket bolt	44 ± 10 N·m (33 ± 7 ft-lb)
Stabilizer link nut	44 ± 10 N·m (33 ± 7 ft-lb)
<b>Strut assembly</b>	
Stabilizer link nut	44 ± 10 N·m (33 ± 7 ft-lb)
Strut assembly jam nut	64 ± 5 N·m (47 ± 4 ft-lb)
Strut assembly to body connection nut	44 ± 5 N·m (33 ± 3 ft-lb)
Strut assembly to knuckle connection nut	300 ± 24 N·m (221 ± 18 ft-lb)

**GENERAL SPECIFICATIONS**

M1332000200103

**COIL SPRING <ECLIPSE>**

ITEMS	RS, GS – M/T	GS – A/T, GT – M/T	GT – A/T
Wire diameter mm (in)	14.3 (0.56)	14.5 (0.57)	14.7 (0.58)
Average diameter mm (in)	169.0 (6.65)	169.0 (6.65)	169.0 (6.65)
Free length mm (in)	311.5 (12.26)	320.0 (12.60)	328.5 (12.93)

**COIL SPRING <ECLIPSE SPYDER>**

ITEMS	GS	GT – M/T	GT – A/T
Wire diameter mm (in)	14.7 (0.58)	15.0 (0.59)	15.2 (0.60)
Average diameter mm (in)	169.0 (6.65)	169.0 (6.65)	169.0 (6.65)
Free length mm (in)	328.5 (12.93)	336.5 (13.25)	345.0 (13.59)

**SERVICE SPECIFICATIONS**

M1332000300155

ITEMS	SPECIFICATIONS		
Toe-in mm (in)	0 ± 3 (0 ± 0.12)		
Steering angle	Inner wheel	2.4L ENGINE	36°12' ± 2°00'
		3.0L ENGINE	31°00' ± 2°00'
	Outer wheel (reference)	2.4L ENGINE	30°24'
		3.0L ENGINE	27°00'
Camber	0°00' ± 30' (Left/right deviation within 30')		
Caster	3°00' ± 30' (Left/right deviation within 30')		
Lower arm ball joint breakaway torque N·m (in-lb)	2.5 – 6.1 (22 – 54)		
Stabilizer link ball joint breakaway torque N·m (in-lb)	3.4 – 9.0 (30 – 80)		

**COMPONENT IDENTIFICATION**

M1331001300100

**CAMBER ADJUSTING BOLT**

BOLT DIAMETER mm (in)	NUMBER OF IDENTIFICATION PROJECTION	
Set bolt	0	
Adjusting bolt	14.9 (0.59)	1
	14.1 (0.56)	2
	13.6 (0.54)	3