

## GROUP 27

**REAR AXLE****CONTENTS**

<b>GENERAL DESCRIPTION</b> .....	<b>27-2</b>	REAR HUB ROTARY-SLIDING RESISTANCE CHECK .....	27-4
<b>REAR AXLE DIAGNOSIS</b> .....	<b>27-2</b>	HUB BOLT REPLACEMENT .....	27-4
INTRODUCTION TO REAR AXLE DIAGNOSIS .....	27-2	<b>REAR AXLE HUB ASSEMBLY</b> .....	<b>27-5</b>
REAR AXLE DIAGNOSTIC TROUBLESHOOTING STRATEGY .....	27-2	REMOVAL AND INSTALLATION .....	27-5
SYMPTOM CHART .....	27-2	INSPECTION .....	27-6
SYMPTOM PROCEDURES .....	27-3	<b>KNUCKLE</b> .....	<b>27-7</b>
<b>SPECIAL TOOLS</b> .....	<b>27-3</b>	REMOVAL AND INSTALLATION .....	27-7
<b>ON-VEHICLE SERVICE</b> .....	<b>27-4</b>	INSPECTION .....	27-8
WHEEL BEARING END PLAY CHECK ...	27-4	<b>SPECIFICATIONS</b> .....	<b>27-8</b>
		FASTENER TIGHTENING SPECIFICATIONS .....	27-8
		SERVICE SPECIFICATIONS .....	27-8

## GENERAL DESCRIPTION

The rear axle consists of a knuckle, rear hub, unit bearing. The unit bearing is press-fitted to the rear hub and bolted to the knuckle. Also, the unit bearing utilizes the same type of double row angular contact ball bearing as does the front axle.

M1271000100069  
ABS rotor for detecting the vehicle speed is located on the hub assembly, and a speed sensor is located on the knuckle.

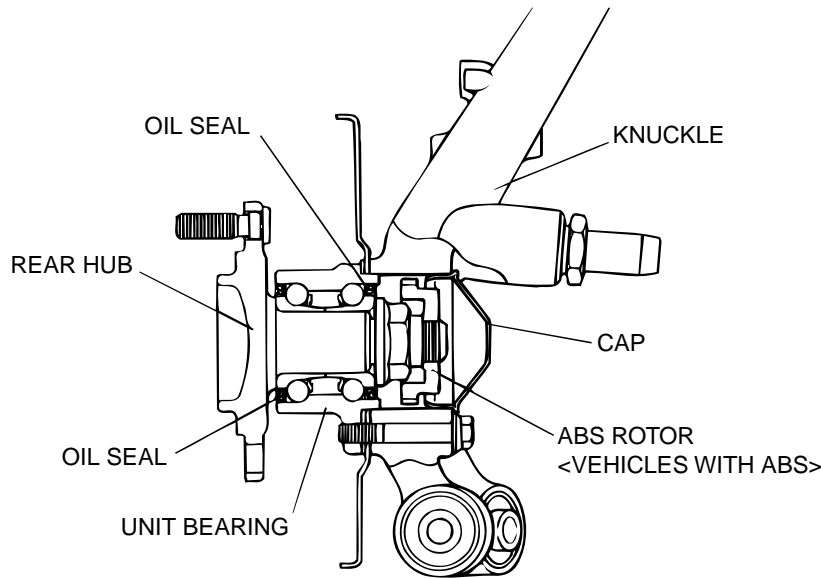

AC001179 AB

## REAR AXLE DIAGNOSIS

### INTRODUCTION TO REAR AXLE DIAGNOSIS

Noise from the rear axle may be caused by defects in the components.

M1271004100072

### REAR AXLE DIAGNOSTIC TROUBLESHOOTING STRATEGY

Use these steps to plan your diagnostic strategy. If you follow them carefully, you will be sure that you have exhausted most of the possible ways to find a rear axle fault.

M1271004200079

1. Gather information from the customer.

2. Verify that the condition described by the customer exists.
3. Find the malfunction by following the Inspection Chart for Trouble Symptoms.
4. Verify malfunction is eliminated.

### SYMPTOM CHART

M1271004300076

SYMPTOM	INSPECTION PROCEDURE	REFERENCE PAGE
Abnormal noise	1	<a href="#">P.27-3</a>

**SYMPTOM PROCEDURES**

M1271004400103

**INSPECTION PROCEDURE 1: Abnormal Noise**

**DIAGNOSIS**

**STEP 1. Check the wheel nut for looseness.**

**Q: Are the wheel nuts loosened?**

**YES :** Tighten the nuts, then go to Step3.

**NO :** Go to Step 2.

**STEP 2. Check the wheel bearing for wear or damage.**

**Q: Is the wheel bearing in good condition?**

**YES :** Go to step 3.

**NO :** Replace the part, then go to Step 4.

**STEP 3. Check the brake disc for bent or distortion.**

**Q: Is the brake disc in good condition?**

**YES :** Go to Step 4.

**NO :** Replace the part, then go to Step 4.

**STEP 4. Check trouble symptoms.**

**Q: Are any noises generated?**

**YES :** Return to Step 1.

**NO :** This diagnosis is complete.

**SPECIAL TOOLS**

M1271000600064

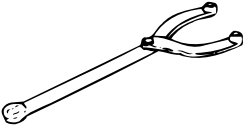
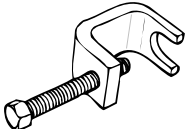
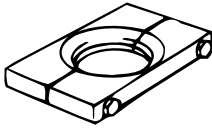
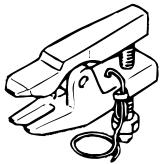
TOOL	TOOL NUMBER AND NAME	SUPERSESSION	APPLICATION
 <p>MB990767</p>	MB990767 End yoke holder	MB990767-1	Hub fixing
 <p>MB991618</p>	MB991618 Hub bolt remover	General service tool	Hub bolt removal
 <p>MB991248</p>	MB991248 Inner shaft remover	Tool not available	ABS rotor removal
 <p>MB990635</p>	MB990635 or MB991113 Steering linkage puller	MB991113-1, MB990635-01 or General service tool	Ball joint disconnection

## ON-VEHICLE SERVICE

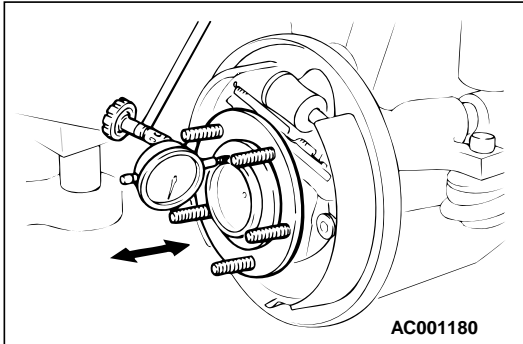

## WHEEL BEARING END PLAY CHECK

M127100900076

1. For vehicles with rear disc brakes, remove the caliper assembly, suspend the caliper assembly with a wire and remove the brake disc.
2. For vehicles with rear drum brakes, remove the brake drum.
3. Check the bearing's end play.  
Place a dial gauge against the hub surface; then move the hub in the axial direction and check whether or not there is end play.

**Limit: 0.05 mm (0.002 inch)**

4. If the play exceeds the limit value, replace the rear hub assembly.

## REAR HUB ROTARY-SLIDING RESISTANCE CHECK

M1271001100051

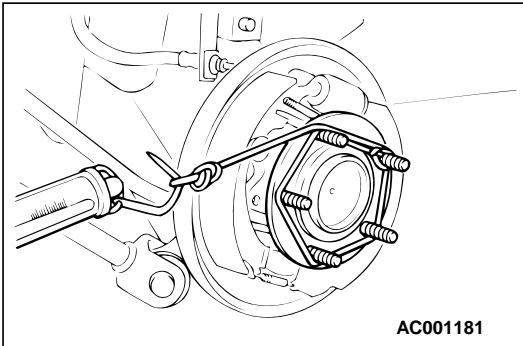

1. For vehicles with rear disc brakes, remove the caliper assembly, suspend the caliper assembly with a wire and remove the brake disc.
2. For vehicles with rear drum brakes, remove the brake drum.
3. After turning the hub a few times to seat the bearing, wind a rope around the hub bolt and turn the hub by pulling at a 90 degree angle with a spring scale. Measure to determine whether or not the rotary-sliding resistance of the rear hub is at the limit value.

**Limit: 18 N·m (13 ft·lb)**

4. If the rotary-sliding resistance exceeds the limit value, replace the rear hub assembly.

## HUB BOLT REPLACEMENT

M1271001000054

## Required Special Tools:

- MB990767: End Yoke Holder
- MB991618: Hub Bolt Remover

1. For vehicles with rear disc brakes, remove the caliper assembly, suspend the caliper assembly with a wire and remove the brake disc.
2. For vehicles with rear drum brake, remove the brake drum.
3. Pull the hub bolt out using special tools MB990767 and MB991618.

*NOTE: For vehicles with drum brakes, the hub bolts should be removed near the retainer spring installation position in order to maintain enough clearance for removal.*

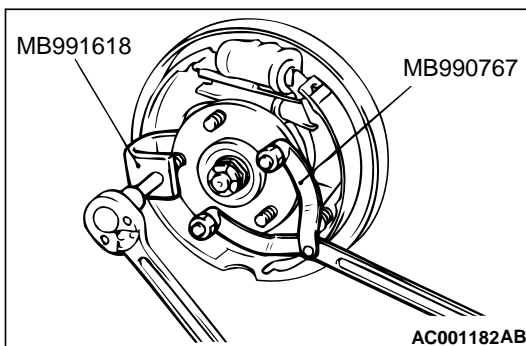

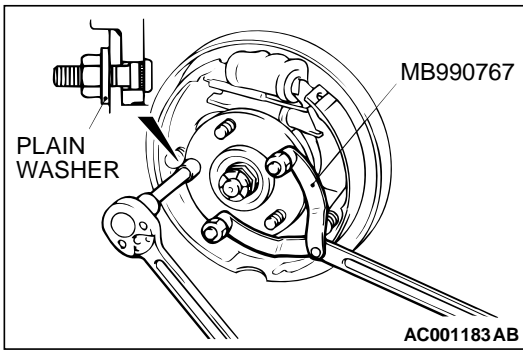

4. Install the plain washer to the new hub bolt, and install the bolt with a nut.

## REAR AXLE HUB ASSEMBLY

### REMOVAL AND INSTALLATION

M1271002000057

**CAUTION**

The rear hub unit bearing should not be dismantled.

<VEHICLES WITH REAR DRUM BRAKE>

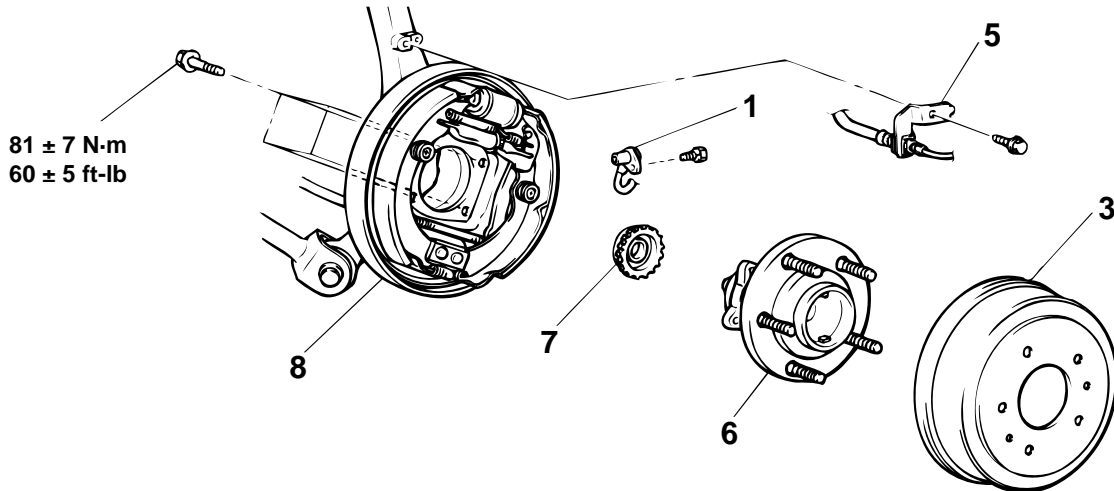

<VEHICLES WITH REAR DISC BRAKE>

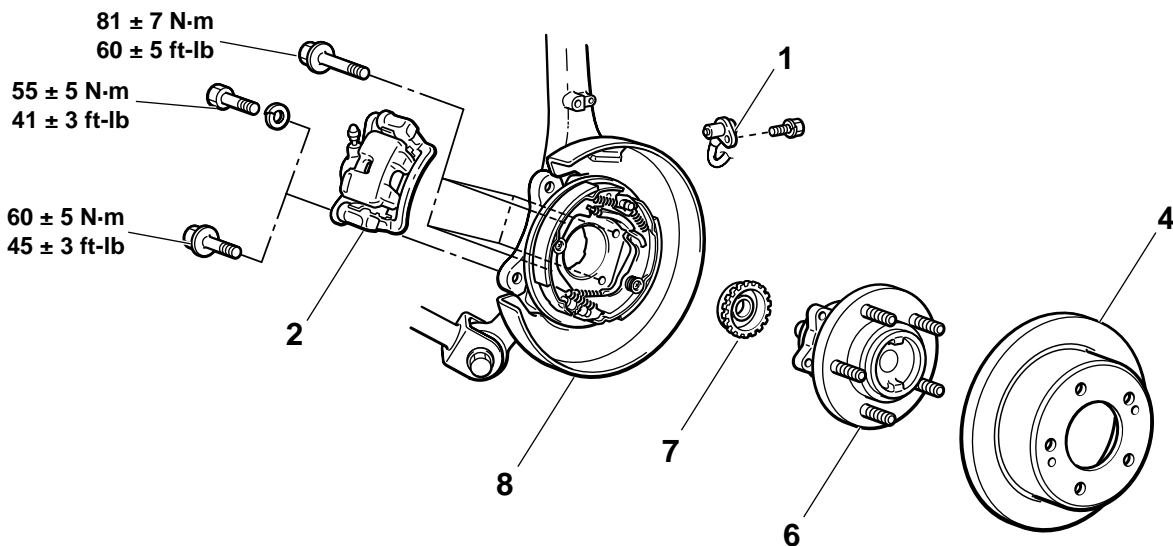

AC000977 AD

TSB Revision

**REMOVAL STEPS**

&lt;&lt;A&gt;&gt;

1. REAR WHEEL SPEED SENSOR <VEHICLES WITH ABS> (REFER TO GROUP 35B P.35B-53.)
2. CALIPER ASSEMBLY
3. BRAKE DRUM
4. BRAKE DISC
5. BRAKE HOSE INSTALLATION BRACKET
6. REAR HUB ASSEMBLY

<<B>> >>A<<  
<<C>>

**REMOVAL STEPS (Continued)**

7. ABS ROTOR <VEHICLES WITH ABS>
8. BACKING PLATE

**Required Special Tool:**

- MB991248: Inner Shaft Remover

**REMOVAL SERVICE POINTS****<<A>> CALIPER ASSEMBLY REMOVAL**

Remove the caliper assembly and suspend it with a wire.

**<<B>> ABS ROTOR REMOVAL**

Use special tool MB991248 to remove the ABS rotor.

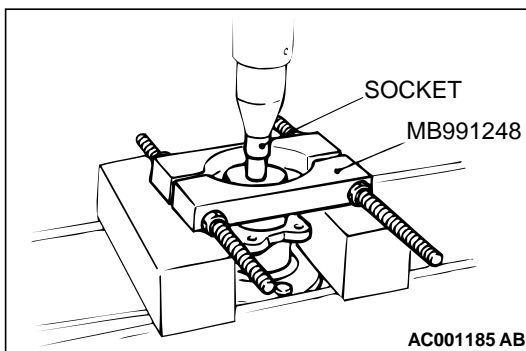
**<<C>> BACKING PLATE REMOVAL**

Remove the backing plate and suspend it.

**INSTALLATION SERVICE POINT****>>A<< ABS ROTOR INSTALLATION**

Install the ABS rotor as shown in the illustration.

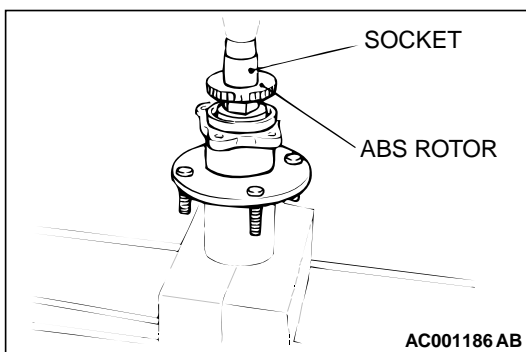
**INSPECTION**

- Check the oil seal for crack or damage.
- Check the ABS rotor for chipped teeth.

M1271002100065

# KNUCKLE

## REMOVAL AND INSTALLATION

M1271003000061

**CAUTION**

\*: Indicates parts which should be temporarily tightened, and then fully tightened with the vehicle on the ground in the unladen condition.

<p><b>Pre-removal Operation</b> Rear Axle Hub Assembly Removal (Refer to P.27-5.)</p>	<p><b>Post-installation Operation</b></p> <ul style="list-style-type: none"> <li>• Check the Dust Cover for Cracks or Damage by Pushing It with Finger.</li> <li>• Rear Axle Hub Assembly Installation (Refer to P.27-5.)</li> </ul>
---	--

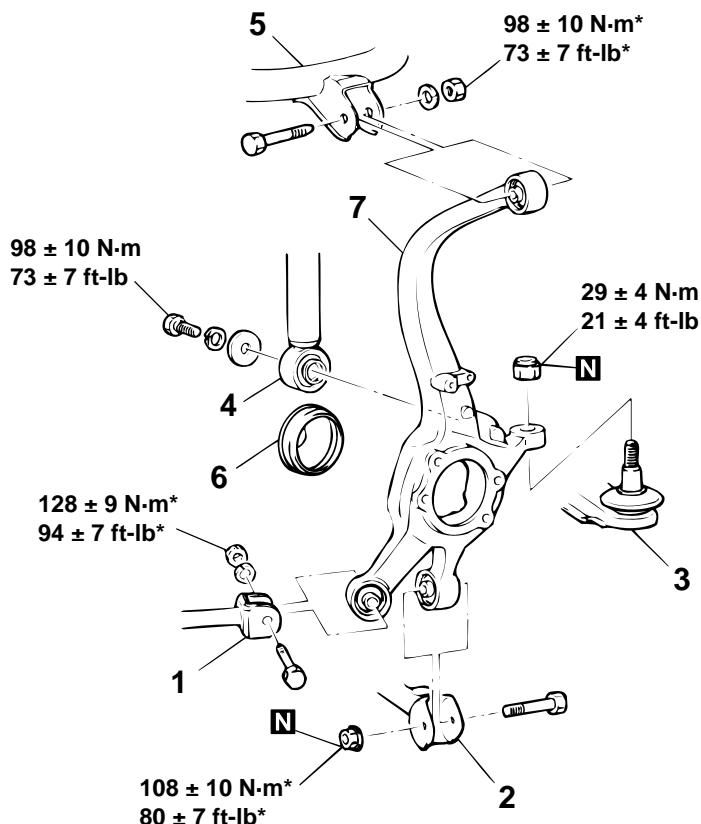

AC001187 AB

**REMOVAL STEPS**

1. TRAILING ARM CONNECTION
2. LOWER ARM CONNECTION
3. TOE CONTROL ARM CONNECTION
4. SHOCK ABSORBER CONNECTION
5. UPPER ARM CONNECTION

**REMOVAL STEPS (Continued)**

6. HUB CAP
7. KNUCKLE

**Required Special Tool:**

- MB991113 or MB990635: Steering Linkage Puller

<<A>>

TSB Revision

## REMOVAL SERVICE POINT

## &lt;&lt;A&gt;&gt; TOE CONTROL ARM DISCONNECTION

**CAUTION**

- Loosen the nut from the ball joint instead of removing it.
- Hang special tool MB991113 or MB990635 with a cord, etc. to prevent it from falling.

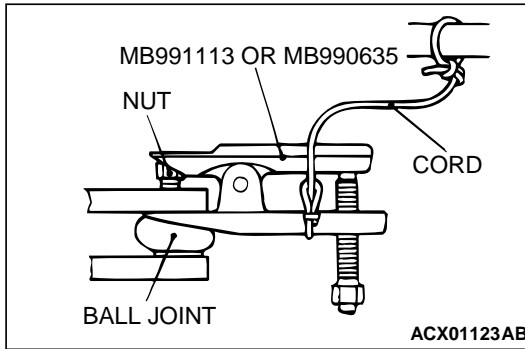

## INSPECTION

Check the knuckle for wear or cracks.

M1271003100046

## SPECIFICATIONS

## FASTENER TIGHTENING SPECIFICATIONS

M1271004000064

ITEMS	SPECIFICATIONS
Brake caliper assembly bolt <flange bolt>	60 ± 5 N·m (45 ± 3 ft-lb)
Brake caliper assembly bolt <bolt and washer>	55 ± 5 N·m (41 ± 3 ft-lb)
Lower arm assembly to knuckle jam nut	108 ± 10 N·m (80 ± 7 ft-lb)
Rear hub assembly bolt	81 ± 7 N·m (60 ± 5 ft-lb)
Shock absorber assembly to knuckle bolt	98 ± 10 N·m (73 ± 7 ft-lb)
Toe control arm assembly to knuckle jam nut	29 ± 4 N·m (21 ± 4 ft-lb)
Trailing arm assembly to knuckle nut	128 ± 9 N·m (94 ± 7 ft-lb)
Upper arm assembly to knuckle nut	98 ± 10 N·m (73 ± 7 ft-lb)

## SERVICE SPECIFICATIONS

M1271000300063

ITEMS	LIMIT
Wheel bearing end play mm (in)	0.05 (0.002)
Rear hub rotary-sliding resistance N·m (ft-lb)	18 (13)