GROUP 55

**HEATER, AIR
CONDITIONING AND
VENTILATION**

CONTENTS

GENERAL DESCRIPTION.....	55-2	A/C COMPRESSOR.....	55-10
HEATER AND AIR CONDITIONING SYSTEM.....	55-4	CONDENSER.....	55-10
HEATER CONTROL.....	55-8	DUCTS.....	55-11
		VENTILATION SYSTEM.....	55-11

GENERAL DESCRIPTION

M2551001500028

For the heater and air conditioning system, the heater and cooling unit are combined in a single unit, which, with the mode film damper and flow rate control valve in the heater unit, reduces ventilation resistance, increases fan power, and reduces noise. The manual A/C is standard equipment. The automatic A/C is optional equipment for 3.8 L models.

FEATURES

IMPROVEMENTS IN COMFORT

- Flow rate control valve
- Maximum A/C damper
- Heater and blower combined into in a single unit

IMPROVEMENTS IN OPERATION PERFORMANCE

- Enlargement of heater control dial
- Enlargement of label for heater control dial
- Electronics incorporated in temperature control dial and mode selection dial for heater control
- Green light used for air conditioner indicator

- Maximum A/C position added to temperature control dial for heater control <vehicles with manual A/C>

RELIABILITY

- External temperature prioritization control for linked defroster control
- New model of heater unit
- Blower type defroster

IMPROVEMENTS IN FUEL ECONOMY

- Scrolling compressor
- Larger condenser
- Reduced wiring and lightened vehicle weight by using CAN communication system

GLOBAL ENVIRONMENT PROTECTION

- New refrigerant system
- Detection control for refrigerant leaks
- Integration of condenser with receiver

IMPROVEMENTS IN SERVICE QUALITY

- One-shot coupling at the joints of the flexible suction hose and suction pipe

SPECIFICATIONS

ITEM		SPECIFICATION
Air conditioning switch type		Push button type
Compressor type		MSC105CA
Cooling output		5.5 kW
Heating output		5.7 kW
Refrigerant	Type	R134a (HFC-134a)
	Charge quantity g (oz)	530 – 570 (18.7 – 20.1)

CONSTRUCTION DIAGRAM

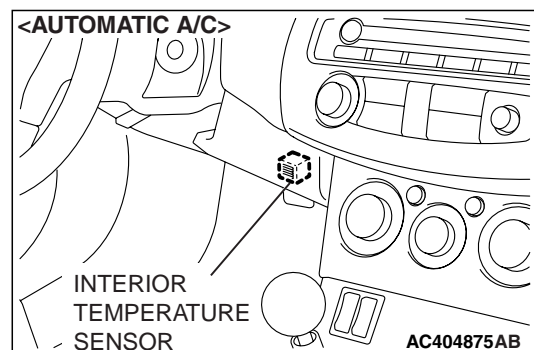
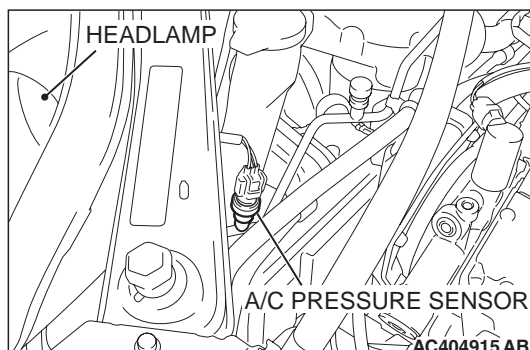

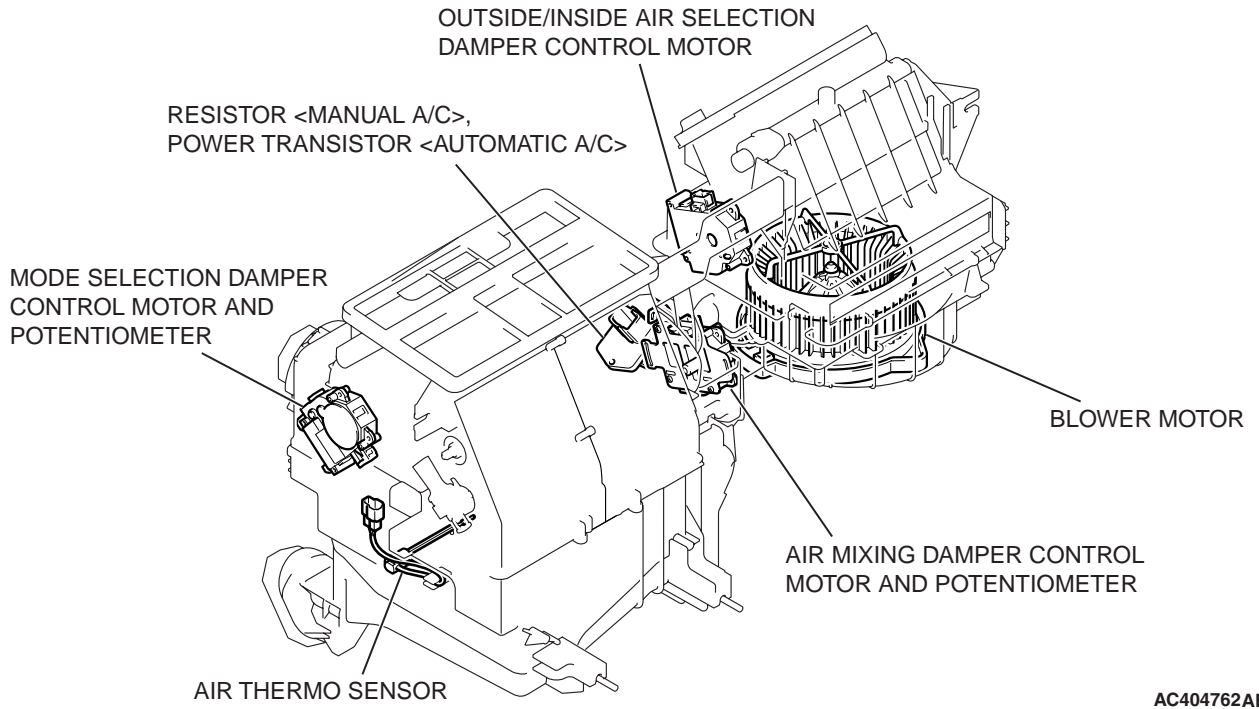
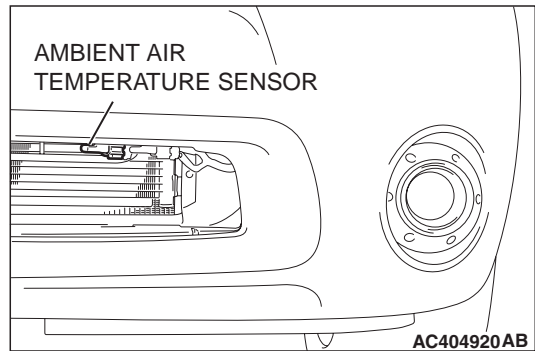
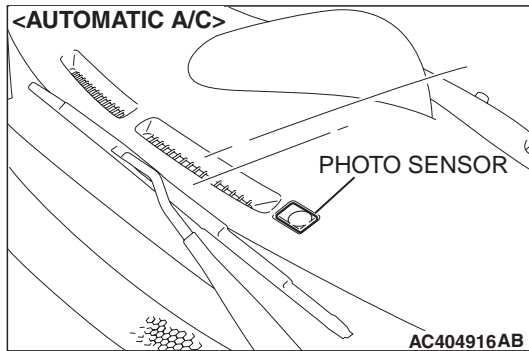

HEATER AND AIR CONDITIONING SYSTEM

M2551001000443

AIR CONDITIONING SYSTEM

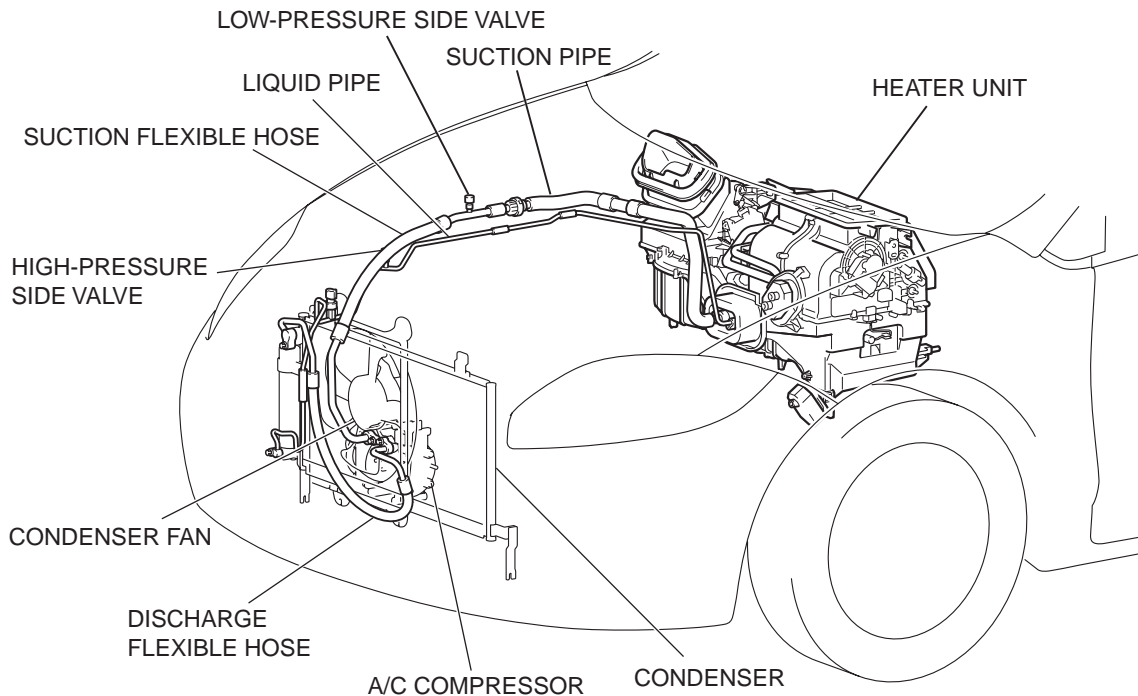

AC404813AB

The following features improve maintenance, reduce vibration transmissibility, and improve cooling and heating performance.

- A scrolling compressor is used for greater compression efficiency of the refrigerant and improvement of cooling performance when idling.
- The scrolling portion of the A/C compressor is more durable and longer lasting.
- Air conditioner piping layout is simplified for fewer refrigerant leaks.
- For easier maintenance, one-shot coupling is used at the joints of the flexible suction hose and suction pipe.

ONE-SHOT COUPLING

The refrigerant line maintenance is simplified by affixing the points of pipe connection with polymer hooks.

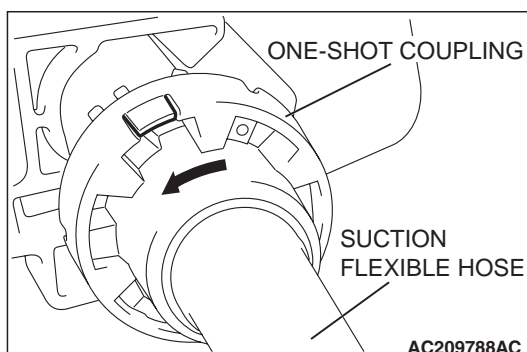

AC209788AC

HEATER UNIT ASSEMBLY

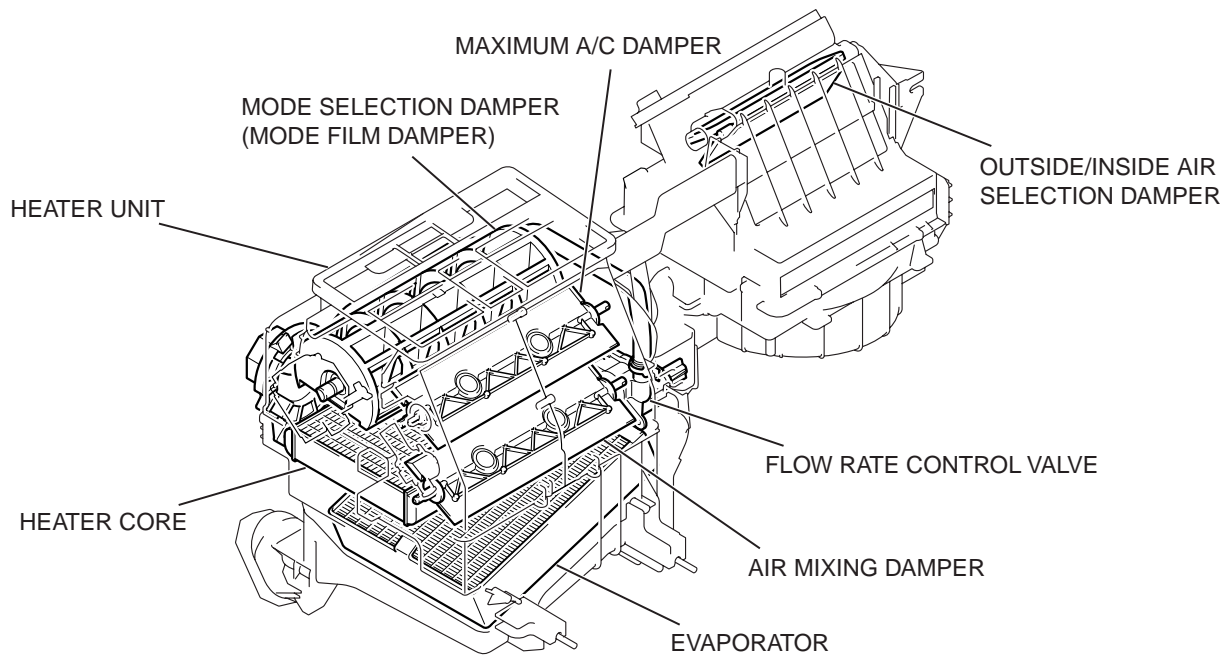

AC404991AB

The following features provide greater fan power, reduced noise, better energy efficiency, and improved cooler and heater performance.

- The heater and cooler units are combined in a single unit and a mode film damper is installed to reduce ventilation resistance, increase fan power, and lessen the noise.
- A flow rate control valve prevents blown air reheating when A/C is set to maximum and reduces temperature fluctuation from changes in engine speed.
- A maximum A/C damper produces a greater volume of air when the cooling is set to maximum A/C.
- The heater unit and blower assembly are combined in a single unit for ease of assembly.

OPERATION

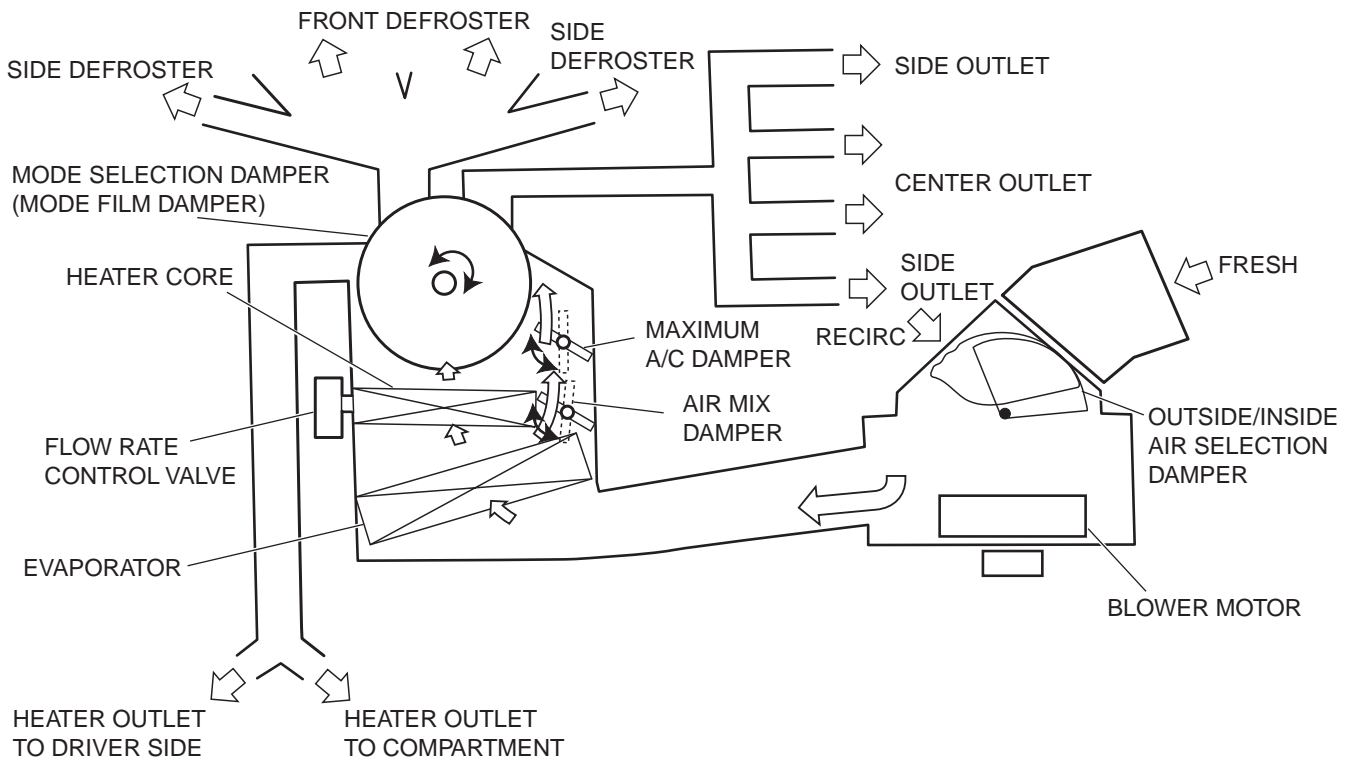

AC406317AB

DURING COOLING

Air is blown by the blower unit (blower motor) to the evaporator where it is cooled. It passes the heater core or the open part of the air mix damper and is blown by the mode film damper to each outlet.

DURING HEATING

Air is blown by the blower unit (blower motor) to the heater core where it is warmed. Next, it is dehumidified by the evaporator. The dehumidified air is warmed by the heater core, and then it is blown by the mode film damper.

FLOW RATE CONTROL VALVE

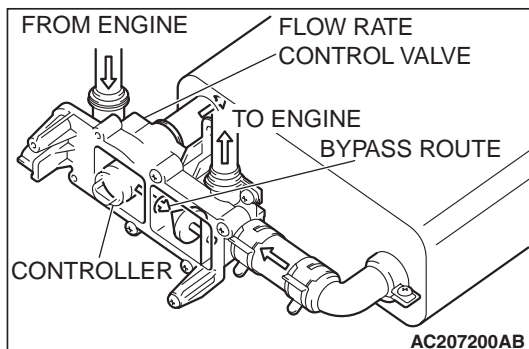

The flow rate control valve controls the amount of coolant that flows to the heater core, simplifying the internal heater unit structure, reducing ventilation resistance, and increasing fan power. Coolant is stopped from flowing to the heater core when the control is set to maximum A/C, which prevents reheating of the cooled air.

MODE FILM DAMPER

A mode film damper is used as a mode selection damper to reduce ventilation resistance, increase fan power, and reduce noise.

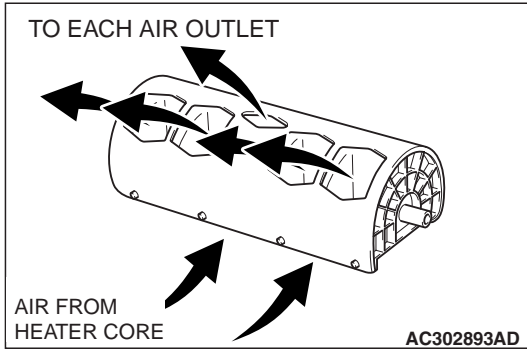

OPERATION

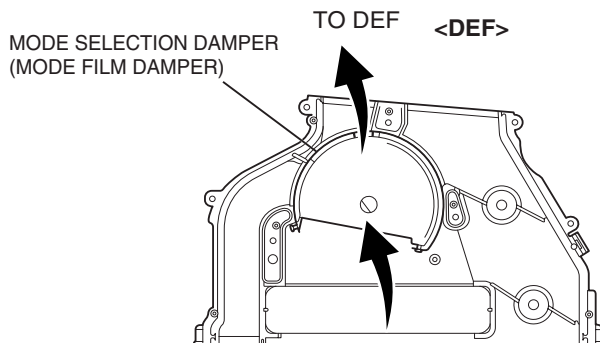
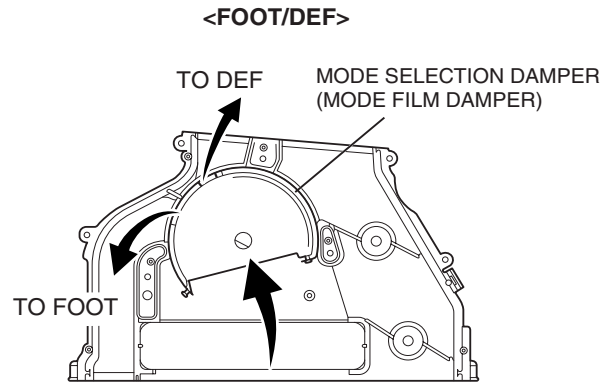
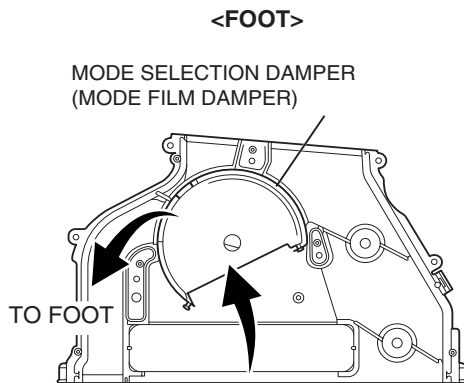
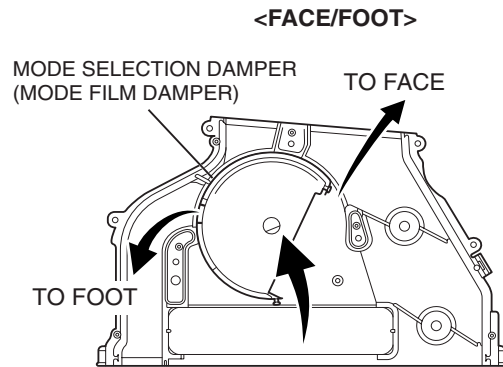
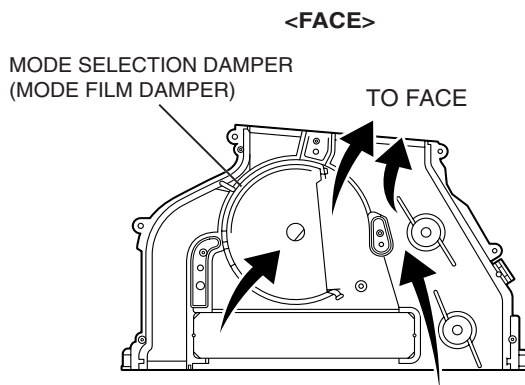

AC500161AB

Turn the mode selection damper motor to change the air outlet direction and air flow.

HEATER CONTROL

M2551000900175

HEATER CONTROLLER (A/C-ECU)

<MANUAL A/C>

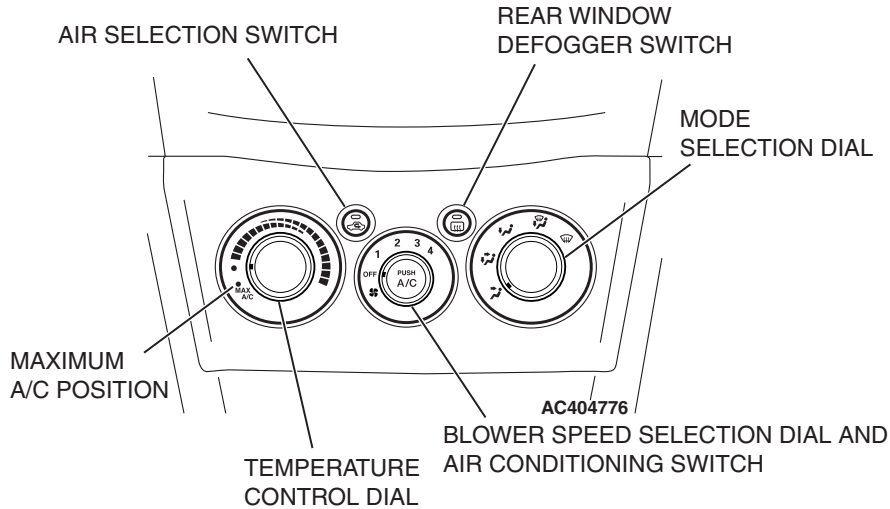

<AUTOMATIC A/C>

<VEHICLES FOR USA>

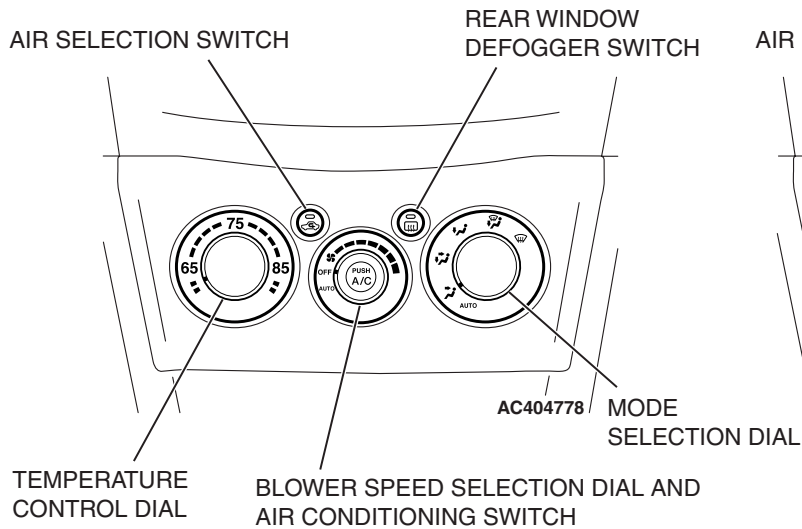

<VEHICLES FOR CANADA>

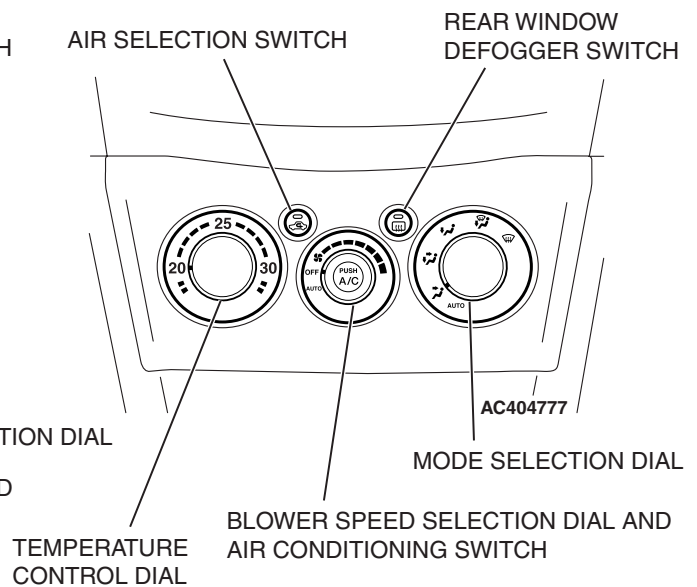

AC405049AB

The features of the heater controller described below are designed for better operation and easier visual recognition.

- Enlargement of the dials
- Improvement of operational response through electronics in temperature control dial and mode selection dial
- Coordinated illumination with the same ice-blue LED illumination for the combination meter and audio controls <vehicles with automatic A/C or manual A/C>
- Easier visual recognition with green used for the A/C indicator
- Better performance when cooling is set at the highest level from the addition of a maximum A/C position on the temperature control dial <vehicles with manual A/C>

- Accidental fogging of windows due to user error is prevented by linking with defroster and fixing internal/external air switching damper in an open position
- Optimal blowing mode and fan power control based on data from external temperature sensor, sunlight sensor, and interior temperature sensor <vehicles with automatic A/C>
- Blowing mode can now be controlled automatically, separately from the fan level set by the user, by setting the mode selection dial to automatic <vehicles with automatic A/C>
- Fan power can now be controlled automatically, separately from the mode selection set by the user, by setting the fan dial to automatic <vehicles with automatic A/C>

REAR WINDOW DEFOGGER TIMER

Automatic shutoff by the heater controller (by the A/C-ECU) after approximately 17 minutes, to prevent battery drain if the rear window defogger is switched on and the user forgets to switch it off.

A/C PRESSURE SENSOR

This sensor constantly monitors the refrigerant pressure for changes, emitting signals as voltage. The voltage emitted from the sensor is received by the heater controller (A/C-ECU), which issues power train control module communication for engine control based on the air conditioner load.

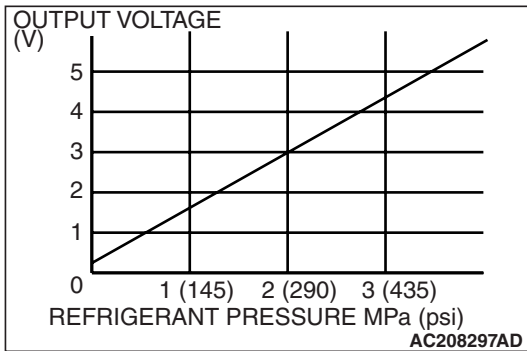

DETECTION CONTROL FOR REFRIGERANT LEAKS

If the external temperature sensor and A/C pressure sensor signal the heater controller (A/C-ECU) that the refrigerant pressure has dropped below a prescribed level or has reached an abnormal level, the air conditioning system is stopped and the A/C indicator blinks to notify user of malfunction.

CAN COMMUNICATION

The air conditioner receives the following kinds of signals through CAN signals:

Signal Identification	Transmitter ECU
Engine coolant temperature signal	Powertrain control module
Vehicle speed signal	
Engine speed signal	
A/C information signal	
Vehicle stop signal	

The air conditioner transmits the following kinds of signals through CAN signals:

Signal Identification	Receiver ECU
A/C pressure signal	Powertrain control module
A/C switch signal	

A/C COMPRESSOR

M2551001100127

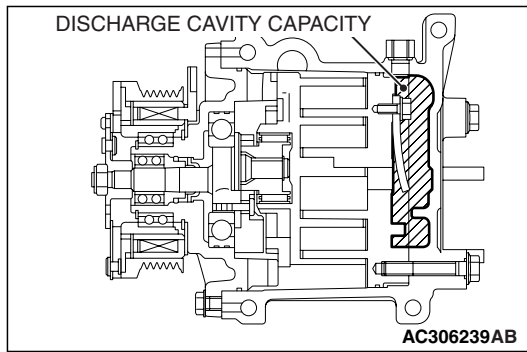

A scrolling compressor with greater compression efficiency is used to improve the cooling performance when idling. Compressor discharge cavity capacity has been expanded to reduce discharge pulse, vibration, and noise.

A/C COMPRESSOR CLUTCH WITH THERMAL FUSE

A thermal fuse is installed in the A/C compressor field core. If the compressor fails, the thermal fuse will be blown due to friction heat produced by the drive belt and locked compressor. This deenergizes the A/C compressor clutch and allows the compressor to run freely.

CONDENSER

M2551001400076

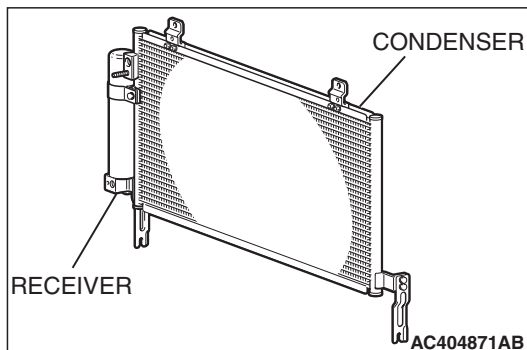

- Improved cooling performance from a larger condenser.
- Combination of condenser with receiver in a single unit and reduction of pipe junctions to reduce refrigerant leaks
- Radiator and condenser in one unit, for reduced body vibration and improved effectiveness of the chassis dynamic damper.

DUCTS

M2551001300143

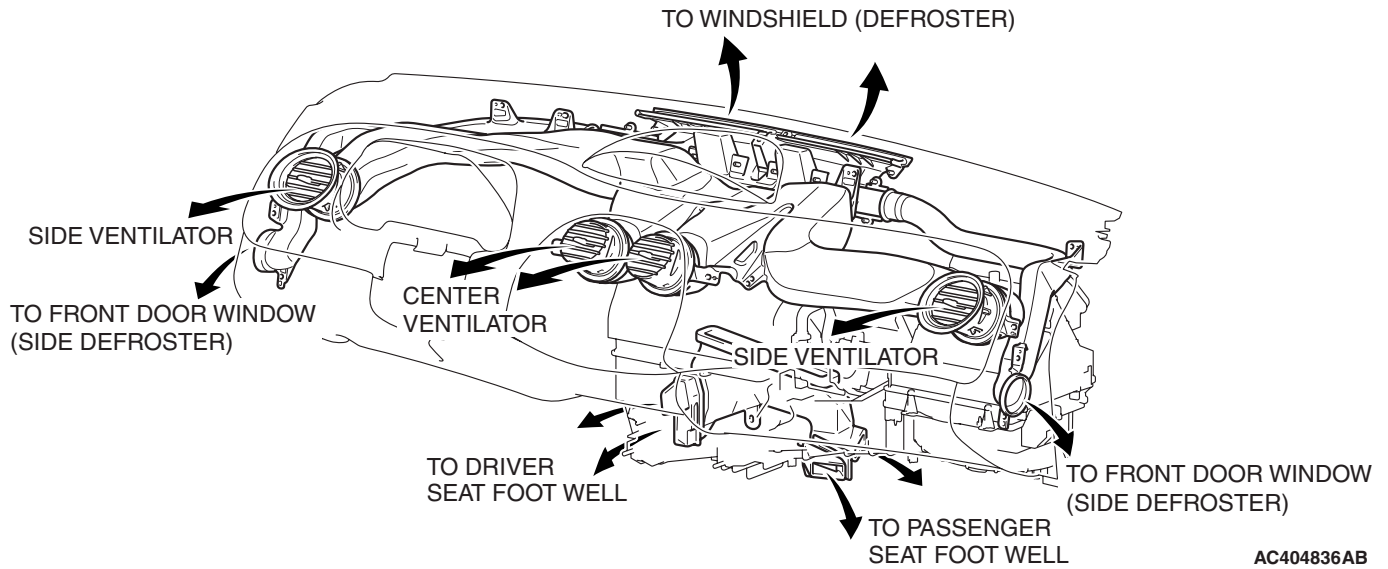

AC404836AB

The fan level and defroster performance have been improved by using the following:

- Greater blowing power from new model of heater unit
- Improved defroster performance from a current-type defroster
- If the outside temperature is cold and the fan level is too low, the blowing mode is switched to automatic for a higher level of defrosting power
- Larger area for vents on the instrument panel air outlets

VENTILATION SYSTEM

M2551002000338

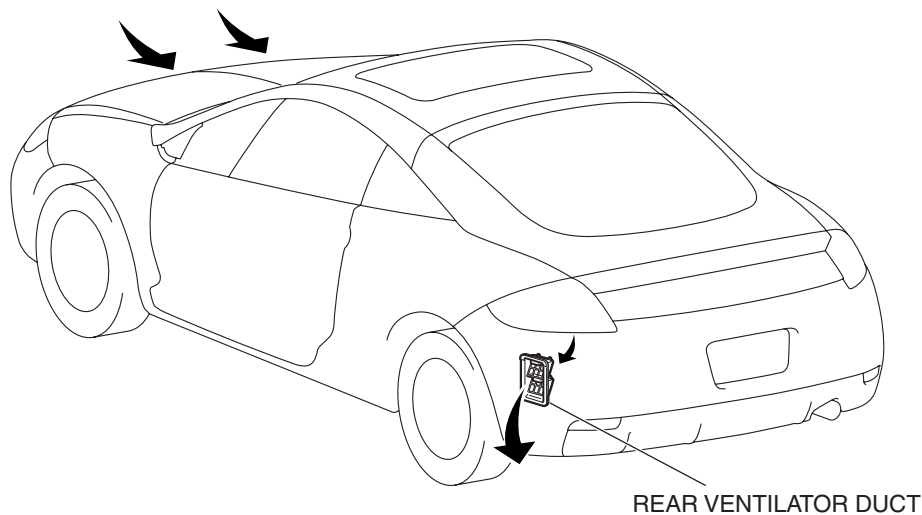

AC404816AB

Fresh air is sucked from the front deck and exhausted through the air outlet behind the rear bumper. Larger outside air induction and the air outlet areas improves ventilated air amount, reducing noise.

NOTES