

GROUP 13C

FUEL SUPPLY

CONTENTS

GENERAL DESCRIPTION	13C-2	FUEL PUMP OPERATION CHECK	13C-6
FUEL SUPPLY DIAGNOSIS	13C-2	FUEL PUMP MODULE REPLACEMENT ..	13C-6
INTRODUCTION.....	13C-2	LEVELING VALVE CHECK.....	13C-8
TROUBLESHOOTING STRATEGY	13C-2	FUEL TANK	13C-9
SYMPTOM PROCEDURES	13C-3	REMOVAL AND INSTALLATION	13C-9
SPECIAL TOOLS	13C-5	INSPECTION.....	13C-15
ON-VEHICLE SERVICE	13C-6	SPECIFICATIONS	13C-16
FUEL LEVEL SENSOR CHECK.....	13C-6	FASTENER TIGHTENING	
FUEL LEVEL SENSOR REPLACEMENT..	13C-6	SPECIFICATION	13C-16
		SERVICE SPECIFICATION	13C-16

GENERAL DESCRIPTION

M1135000100640

- The fuel tank is located under the floor below the rear seats.
- A fuel cut-off valve is utilized to prevent fuel from leaking out in the event of a collision.
- A fuel pump module, including fuel pump, fuel filter, fuel pump pressure regulator and fuel level sensor, is used to lighten weight and improve serviceability.

CONSTRUCTION DIAGRAM

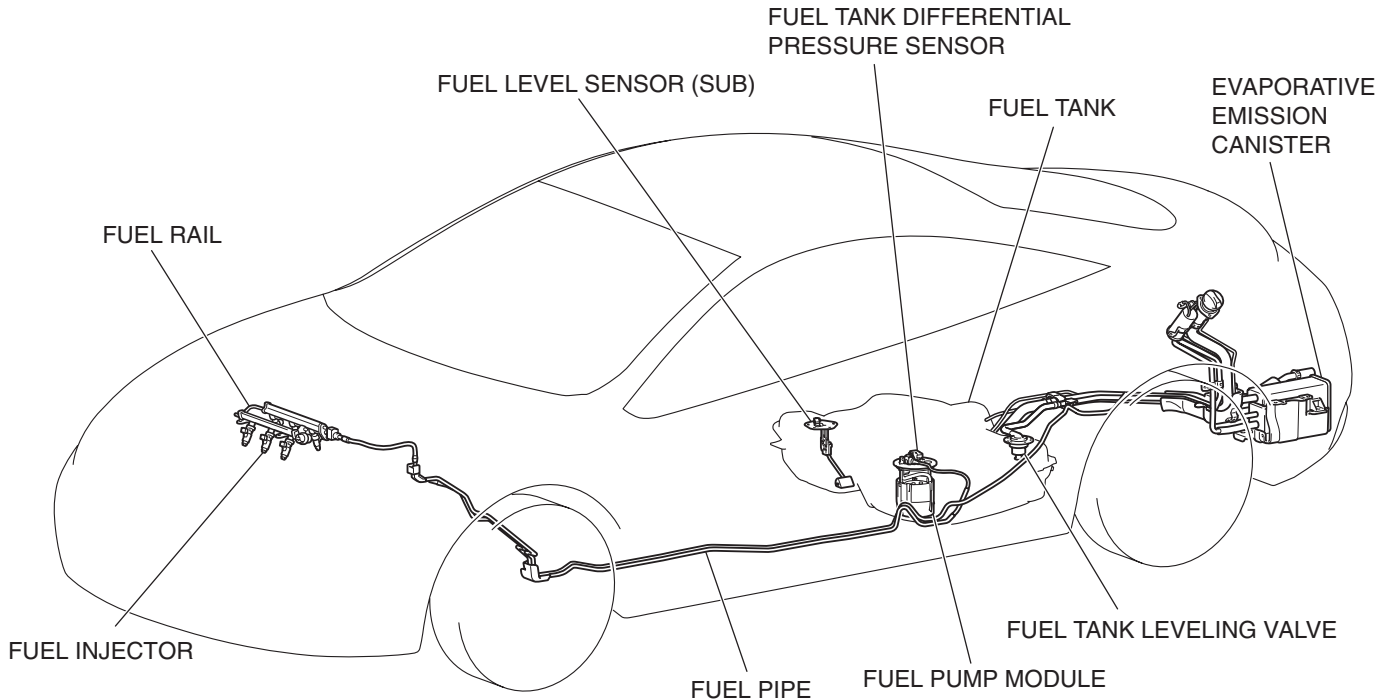

AC404872AB

FUEL SUPPLY DIAGNOSIS

INTRODUCTION

The fuel system supplies an appropriate fuel mixture to the engine. The system consists of the fuel tank, fuel filter, fuel pump and fuel pipes. An evaporative emission system is provided to prevent evaporated fuel from escaping into the atmosphere.

TROUBLESHOOTING STRATEGY

Use these steps to plan your diagnostic strategy. If you follow them carefully, you will be sure to find most of the fuel supply faults.

1. Gather information from the customer.

Engine malfunctions caused by insufficient fuel supply and evaporative emission system operation malfunctions can be caused by faults in the vapor line, fuel pipe, hose, or fuel tank pressure control valve, etc.

M1135004000429

2. Verify that the condition described by the customer exists.
3. Find the malfunction by following the Symptom Procedures.
4. Verify malfunction is eliminated.

M1135004100318

SYMPTOM PROCEDURES

M1135004800328

INSPECTION PROCEDURE 1 : Engine Malfunctions Due to Insufficient Fuel Supply

TROUBLESHOOTING HINTS (The most likely causes for this case:)

- Injector failed.
- Open or shorted injector circuit, or loose connector.
- Bent, twisted or clogged fuel pipe or hose.
- Malfunction of the fuel pump module.

DIAGNOSIS

Required Special Tools:

- MB991958: Scan Tool (MUT-III Sub Assembly)
 - MB991824: V.C.I.
 - MB991827: USB Cable
 - MB991910: Main Harness A

STEP 1. Using scan tool MB991958, read the diagnostic trouble code (DTC).

⚠ CAUTION

To prevent damage to scan tool MB991958, always turn the ignition switch to the "LOCK" (OFF) position before connecting or disconnecting scan tool MB991958.

- (1) Ensure that the ignition switch is at the "LOCK" (OFF) position.
- (2) Start up the personal computer.
- (3) Connect special tool MB991827 to special tool MB991824 and the personal computer.
- (4) Connect special tool MB991910 to special tool MB991824.
- (5) Connect special tool MB991910 to the data link connector.
- (6) Turn the power switch of special tool MB991824 to the "ON" position.

NOTE: When special tool MB991824 is energized, special tool MB991824 indicator light will be illuminated in a green color.

- (7) Start the MUT-III system on the personal computer.
- (8) Turn the ignition switch to the "ON" position.
- (9) Select "Interactive Diagnosis" from the start-up screen.
- (10) Select "System select."
- (11) Choose "MFI" from the "POWER TRAIN" tab.
- (12) Select "MITSUBISHI."
- (13) Select "Diagnostic Trouble Code."
- (14) If a DTC is set, it is shown.

Q: Is the DTC set?

YES : Refer to Diagnostic Trouble Code Chart. <2.4L Engine>P.13A-41 , <3.8L Engine>P.13B-43.

NO : Turn the ignition switch to the "LOCK" (OFF) position, and then remove scan tool MB991958 in the reverse order of installation. Go to Step 2.

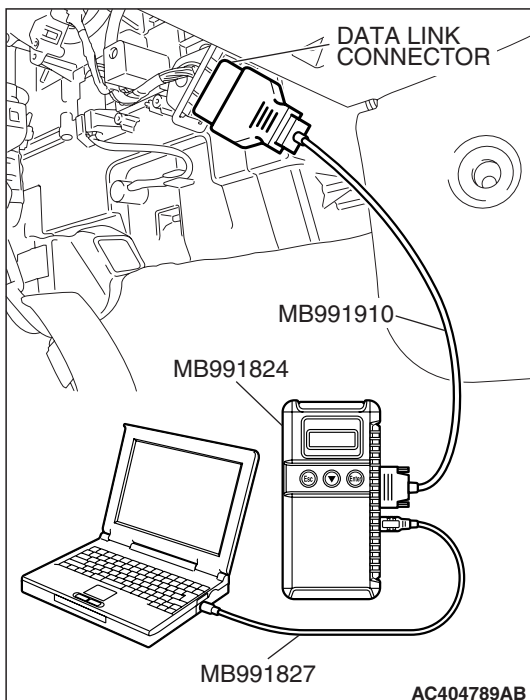

STEP 2. Check the fuel pressure.

Release residual pressure from the fuel line to prevent fuel spray. Refer to Fuel Pressure Test. <2.4L Engine>[P.13A-1197](#) ,<3.8L Engine>[P.13B-1280](#).

Q: Is the fuel pressure in good condition?

YES : Go to Step 5.

NO : Repair or replace. Then go to Step 3.

STEP 3. Check for bending, twisting or clogging of the fuel pipe or hose.**Q: Are the fuel pipe and hose in good condition?**

YES : Go to Step 4.

NO : Repair or replace. Then go to Step 6.

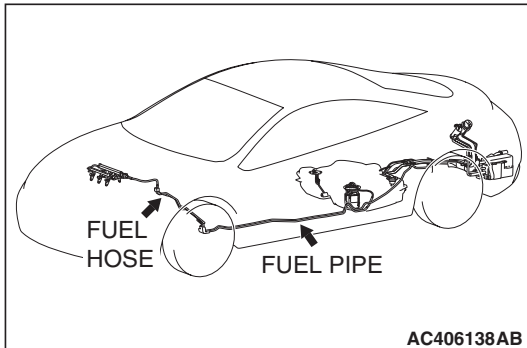
**STEP 4. Check the fuel pump module operation.**

Refer to Fuel Pump Operation Check. <2.4L Engine>[P.13A-1200](#) ,<3.8L Engine>[P.13B-1283](#) .

Q: Is the fuel pump module operation in good condition?

YES : Then go to Step 5.

NO : Replace (Refer to [P.13C-9](#)). Then go to Step 6.

STEP 5. Check the inside of the fuel tank for contamination and rust.

- (1) Drain fuel.
- (2) Remove the fuel tank (Refer to [P.13C-9](#)).

Q: Is the fuel tank in good condition?

YES : Go to Step 6.

NO : Replace the fuel filter, and clean the fuel tank and fuel line. Then go to Step 6.

STEP 6. Retest the system.**Q: Is the engine malfunction eliminated?**

YES : The procedure is complete.

NO : Return to Step 1.

SPECIAL TOOLS

M113500600452

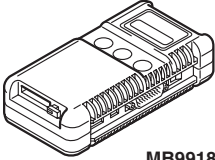
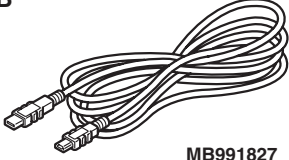
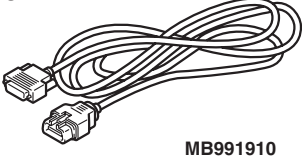
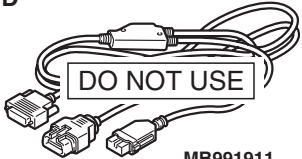
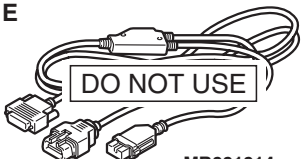
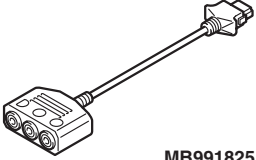
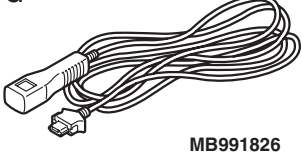
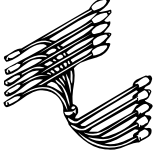
TOOL	TOOL NUMBER AND NAME	SUPERSESION	APPLICATION
<p>A</p>  <p>MB991824</p> <p>B</p>  <p>MB991827</p> <p>C</p>  <p>MB991910</p> <p>D</p>  <p>MB991911</p> <p>E</p>  <p>MB991914</p> <p>F</p>  <p>MB991825</p> <p>G</p>  <p>MB991826 MB991958</p>	<p>MB991958 A: MB991824 B: MB991827 C: MB991910 D: MB991911 E: MB991914 F: MB991825 G: MB991826</p> <p>MUT-III sub assembly A: Vehicle communication interface (V.C.I.) B: MUT-III USB cable C: MUT-III main harness A (Vehicles with CAN communication system) D: MUT-III main harness B (Vehicles without CAN communication system) E: MUT-III main harness C (for Daimler Chrysler models only) F: MUT-III measurement adapter G: MUT-III trigger harness</p>	<p>MB991824-KIT <i>NOTE: G: MB991826 MUT-III Trigger Harness is not necessary when pushing V.C.I. ENTER key.</i></p>	<p>Checking diagnostic trouble codes</p> <p>CAUTION For vehicles with CAN communication, use MUT-III main harness A to send simulated vehicle speed. If you connect MUT-III main harness B instead, the CAN communication does not function correctly.</p>
 <p>MB991658</p>	<p>MB991658 Test harness set</p>	<p>Tool not available</p>	<p>Fuel tank differential pressure sensor check</p>

ON-VEHICLE SERVICE**FUEL LEVEL SENSOR CHECK**

M1135005300100

Refer to GROUP 54A - Combination Meter, On-vehicle Service, Fuel Level Sensor Check [P.54A-129](#).

FUEL LEVEL SENSOR REPLACEMENT

M1135005600048

Refer to [P.13C-9](#).

FUEL PUMP OPERATION CHECK

M1135001000334

<2.4L Engine>: Refer to GROUP 13A - On-vehicle Service, Fuel Pump Operation Check [P.13A-1200](#).

<3.8L Engine>: Refer to GROUP 13B - On-vehicle Service, Fuel Pump Operation Check [P.13B-1283](#).

FUEL PUMP MODULE REPLACEMENT

M1135004900574

1. Remove the rear seat cushion assembly (Refer to GROUP 52A, Rear Seat Assembly [P.52A-49](#)).
2. Remove the hole cover.

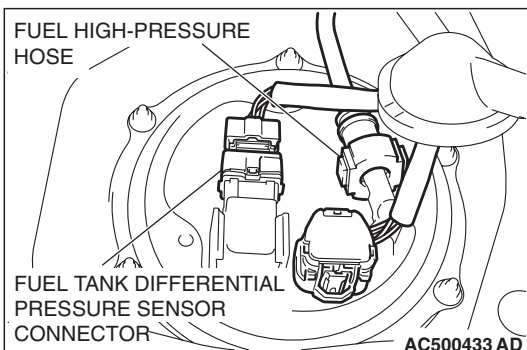
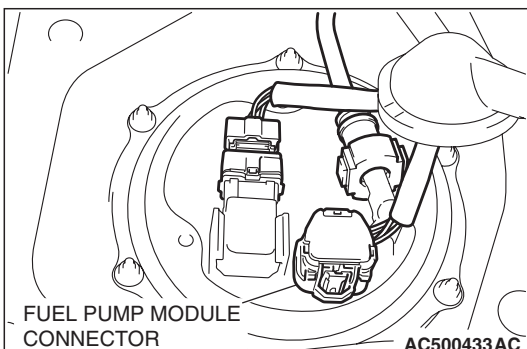
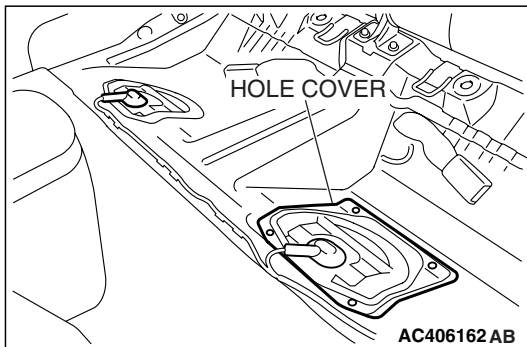

3. Disconnect the fuel pump module connector.
4. Crank the engine for two seconds or more.
5. If the engine does not start, turn the ignition switch to "LOCK" (OFF) position.
6. If the engine starts, stop it naturally and turn the ignition switch to "LOCK" (OFF) position.

⚠ CAUTION

As there will be some pressure remaining in the fuel pipe line, cover it with a shop towel to prevent fuel from spraying out.

7. Disconnect the fuel tank differential pressure sensor connector and fuel high-pressure hose.
8. Remove the fuel pump module mounting nuts.

⚠ CAUTION

- When removing the fuel pump module from the fuel tank, be careful not to spill the fuel remaining in the fuel pump module.
- When withdrawing the fuel pump module from the fuel tank, be careful not to damage the module unit and the float.

9. Drain the fuel remaining in the fuel pump module while removing the fuel pump module from the service hole.

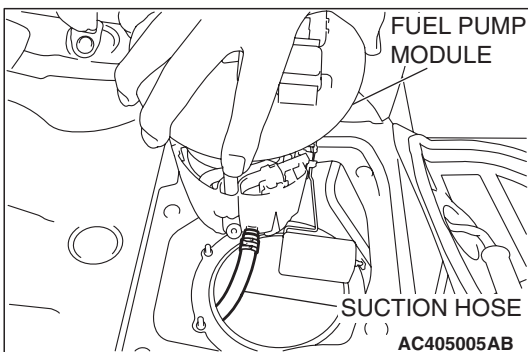
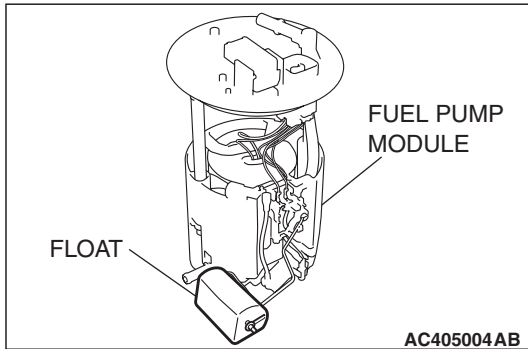

10. Disconnect the suction hose and remove the fuel pump module from the fuel tank.

11. Replace the packing with a new one.

⚠ CAUTION

When installing the fuel pump module into the fuel tank, be careful not to damage the module unit and the float.

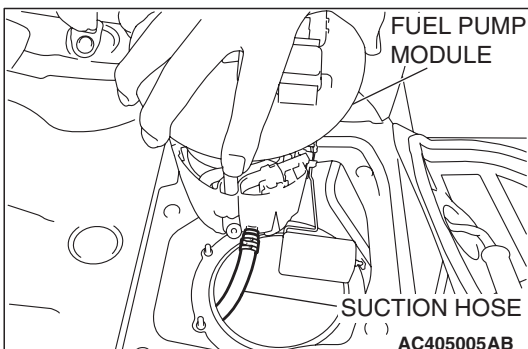
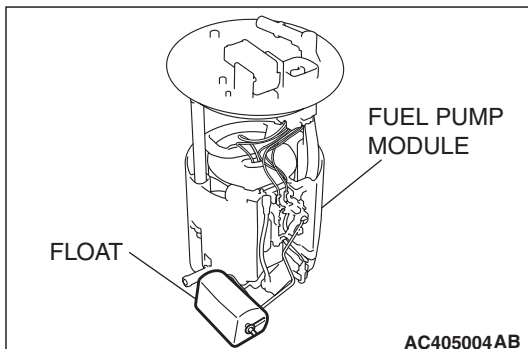

12. Connect the suction hose to the fuel pump module, and install the fuel pump module to the fuel tank whilst ensuring that the suction hose is not kinked.

13. Install the plate to the fuel tank.

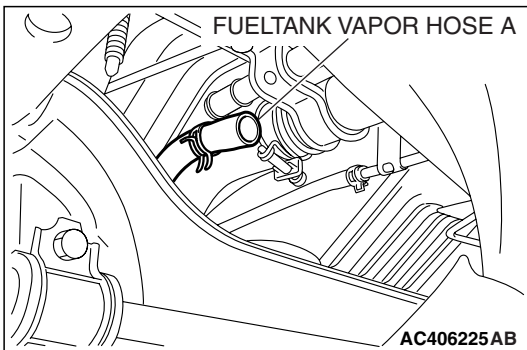
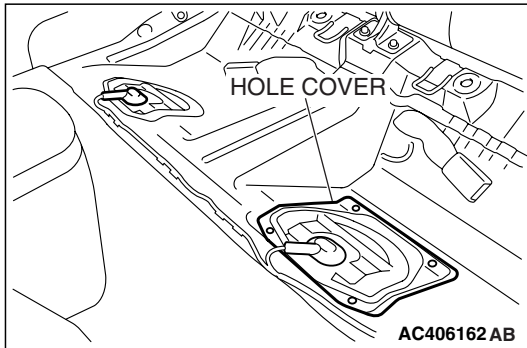
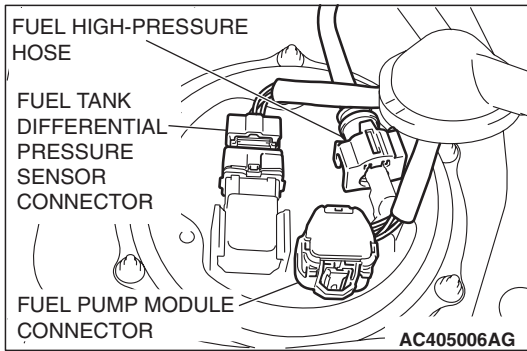

CAUTION

After installing, slightly pull the fuel high-pressure hose and ensure that there is no disengaged fuel high-pressure hose. Also confirm that there is approximately 3 mm (0.12 inch) play at this time.

14. Connect the fuel pump module connector, fuel tank differential pressure sensor connector and fuel high-pressure hose connection.

15. Install the hole cover.

16. Install the rear seat cushion assembly (Refer to GROUP 52A, Rear Seat Assembly P.52A-49).

LEVELING VALVE CHECK

M1135004300174

1. Place a drain pan, and disconnect the fuel tank vapor hose A at pipe side.
NOTE: If fuel leaks from the fuel leveling hose at this stage, the leveling valve may be defective.
2. Open the fuel cap, and fill the fuel tank up.
3. If fuel does not leak from the fuel tank vapor hose A with the fuel tank full, the leveling valve is normal. If it does leak, the leveling valve may be defective. Lower the fuel tank from the vehicle and replace the valve.
4. Reconnect the fuel tank vapor hose A at the pipe side.

FUEL TANK

REMOVAL AND INSTALLATION

M1135001900876

Pre-removal Operation

- Draining Fuel
- Fuel Pump Connector Disconnection (How to Reduce Fuel Pressure) (Refer to GROUP 13A - On-vehicle Service P.13A-1200).
- Center Exhaust Pipe Removal (Refer to GROUP 15 P.15-23).

Pre-installation Operation

- Center Exhaust Pipe Installation (Refer to GROUP 15 P.15-24).
- Refilling Fuel
- Checking for Fuel Leaks

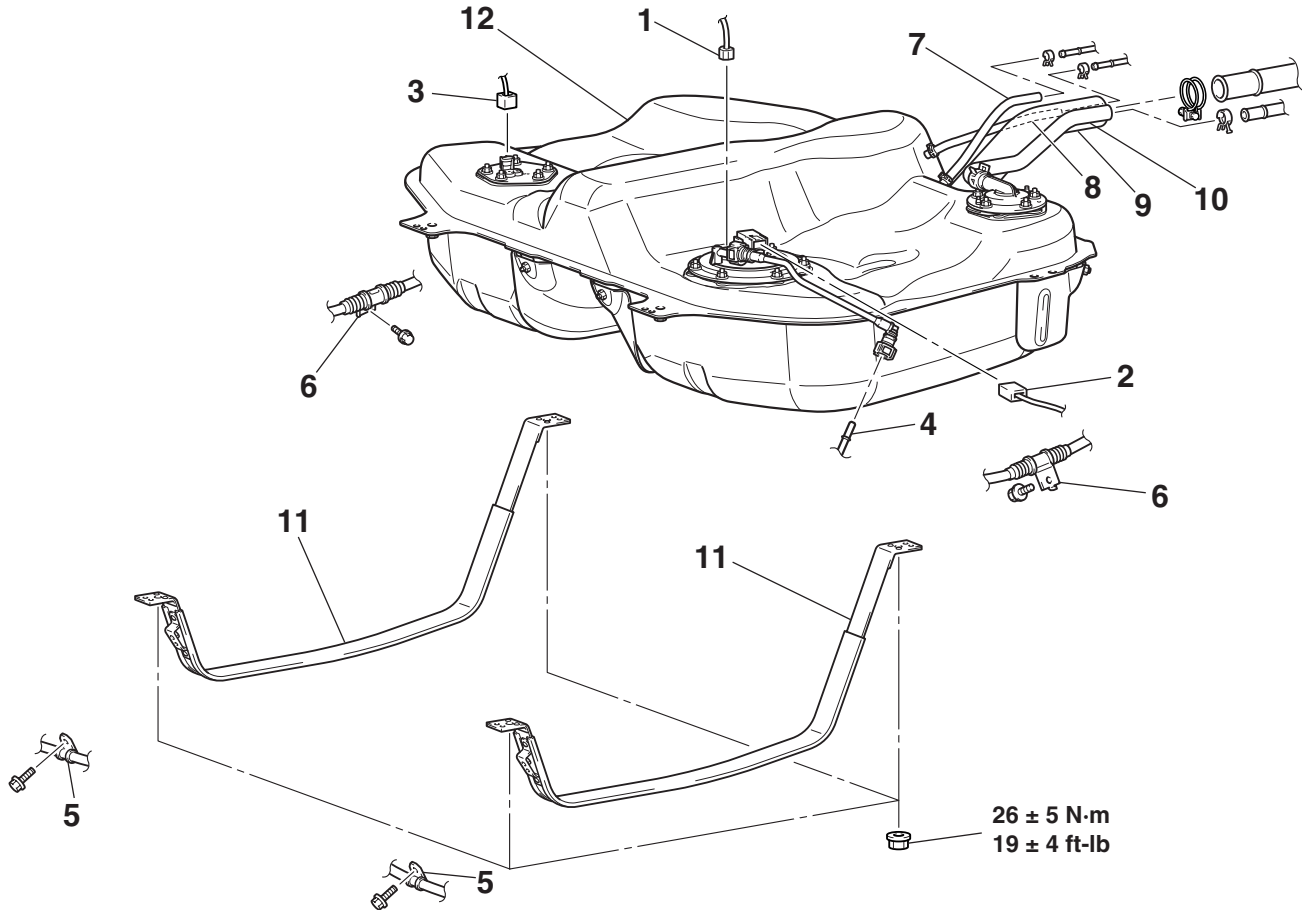

AC500439AB

- FUEL TANK REMOVAL STEPS**
- <<A>> 1. FUEL PUMP MODULE CONNECTOR CONNECTION
 - <<A>> 2. FUEL TANK DIFFERENTIAL PRESSURE SENSOR CONNECTOR CONNECTION
 - <> 3. FUEL LEVEL SENSOR (SUB) CONNECTOR CONNECTION
 - <<C>> >>C<< 4. FUEL HIGH-PRESSURE HOSE CONNECTION
 - 5. PARKING BRAKE CABLE CLAMP CONNECTION

- FUEL TANK REMOVAL STEPS**
- 6. PARKING BRAKE CABLE CLAMP CONNECTION
 - 7. FUEL TANK VAPOR HOSE C CONNECTION
 - 8. FUEL TANK VAPOR HOSE B CONNECTION
 - 9. FUEL FILLER HOSE CONNECTION
 - 10. FUEL TANK VAPOR HOSE A CONNECTION
 - <<D>> >>D<< 11. FUEL TANK BAND
 - <<D>> >>D<< 12. FUEL TANK ASSEMBLY

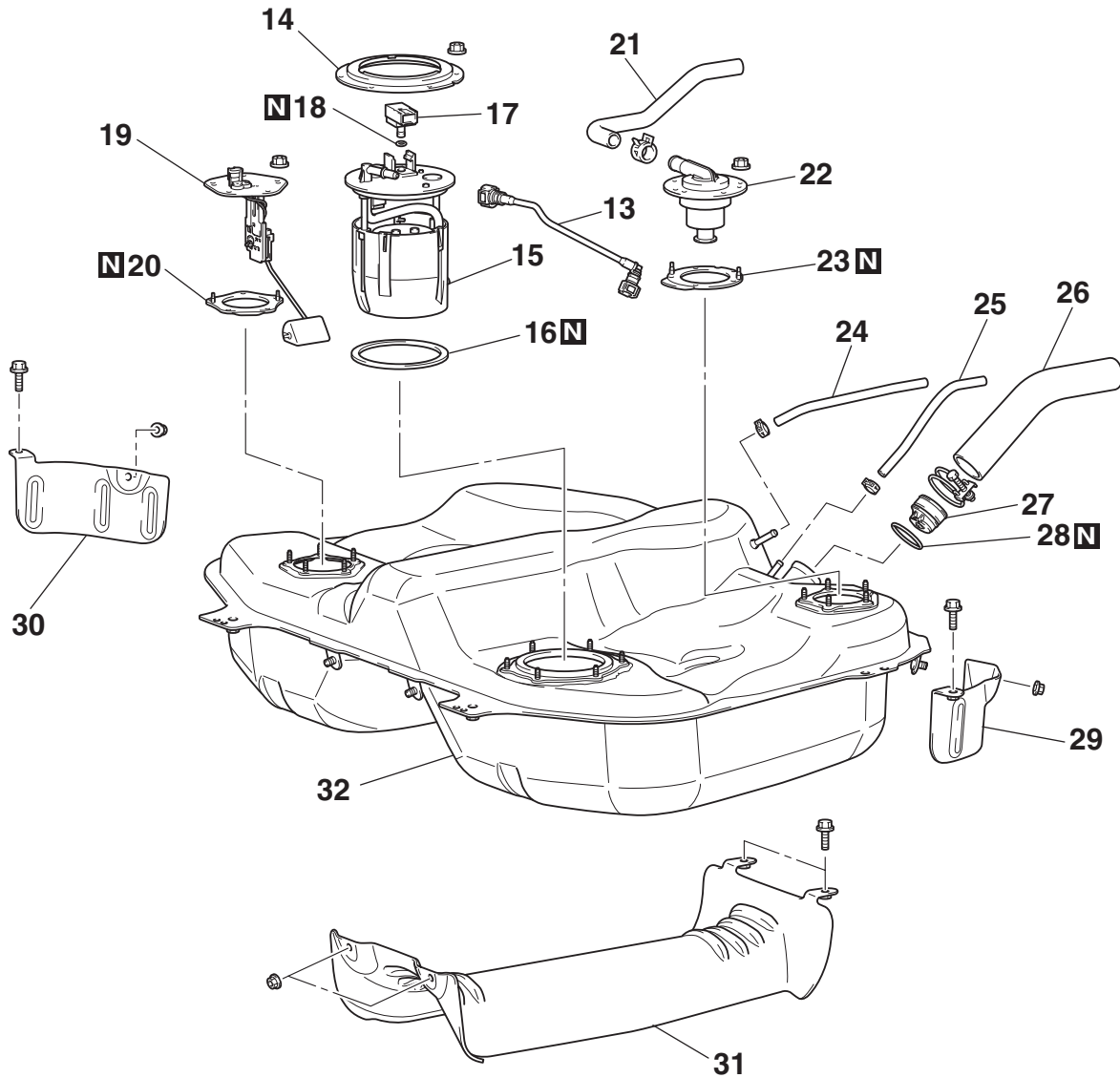

AC500440AB

FUEL TANK REMOVAL STEPS

- >>C<< 13. FUEL HIGH-PRESSURER HOSE
- 14. PLATE
- <<E>> >>B<< 15. FUEL PUMP MODULE
- 16. PACKING
- 17. FUEL TANK DIFFERENTIAL PRESSURE SENSOR
- 18. O-RING
- <<F>> >>A<< 19. FUEL LEVEL SENSOR (SUB)
- 20. PACKING
- 21. FUEL TANK VAPOR TUBE A
- 22. FUEL TANK LEVELING VALVE ASSEMBLY

FUEL TANK REMOVAL STEPS

- 23. PACKING
- 24. FUEL TANK VAPOR HOSE C
- 25. FUEL TANK VAPOR HOSE B
- 26. FUEL FILLER HOSE
- 27. FUEL TANK SHUT-OFF VALVE
- 28. O-RING
- 29. FUEL TANK PROTECTOR (A)
- 30. FUEL TANK PROTECTOR (B)
- 31. FUEL TANK CENTER PROTECTOR
- 32. FUEL TANK

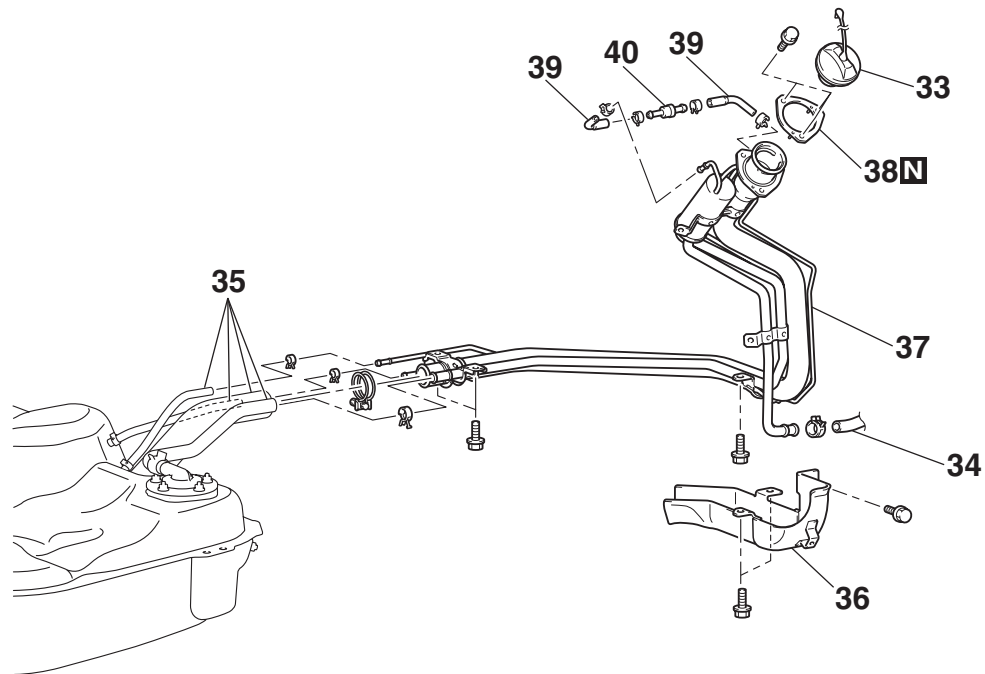

AC406193AB

**FUEL TANK FILLER TUBE
REMOVAL STEPS**

- 33. FUEL CAP
- 34. VAPOR HOSE CONNECTION
- 35. FUEL FILLER HOSE AND FUEL TANK VAPOR HOSE CONNECTION
- 36. FUEL TANK FILLER TUBE PROTECTOR

**FUEL TANK FILLER TUBE
REMOVAL STEPS (Continued)**

- REAR SPLASH SHIELD (REFER TO 51, REAR BUMPER P.51-4).
- 37. FUEL TANK FILLER TUBE
- 38. FUEL TANK FILLER TUBE PACKING
- 39. FUEL TANK FILLER TUBE VAPOR HOSE
- 40. CHECK VALVE

REMOVAL SERVICE POINTS

<<A>> FUEL PUMP MODULE CONNECTOR/FUEL TANK DIFFERENTIAL PRESSURE SENSOR CONNECTOR DISCONNECTION

1. Remove the rear seat cushion assembly (Refer to GROUP 52A, Rear Seat Assembly P.52A-49).
2. Remove the hole cover.

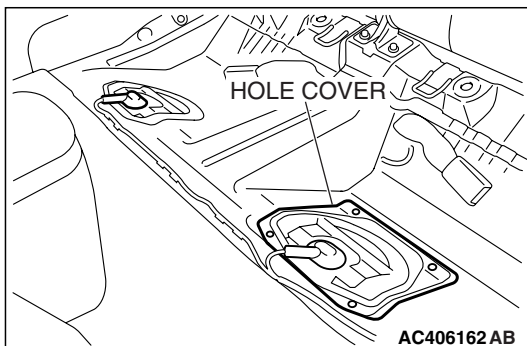

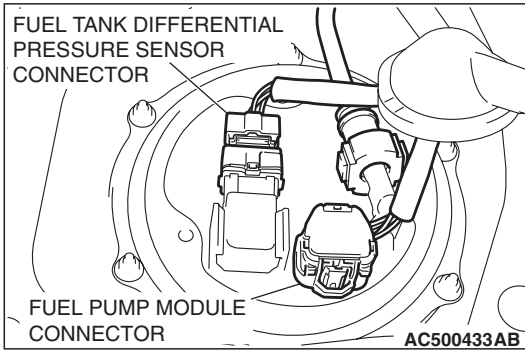

3. Disconnect the fuel pump module connector and fuel tank differential pressure sensor connector connection.

<> FUEL LEVEL SENSOR (SUB) CONNECTOR DISCONNECTION

1. Remove the grommet.

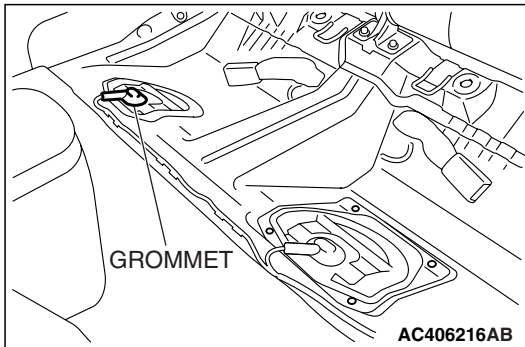

2. Disconnect the fuel level sensor (sub) connector.

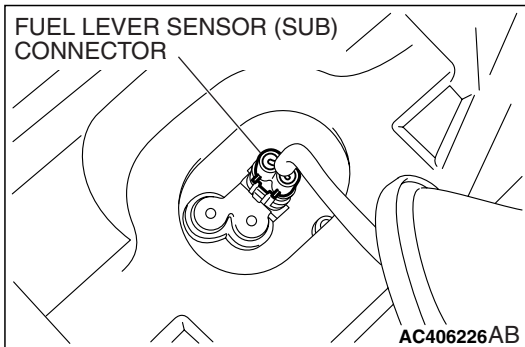

<<C>> FUEL HIGH-PRESSURE HOSE DISCONNECTION

⚠ CAUTION

As there will be some pressure remaining in the fuel pipe line, cover it with a shop towel to prevent fuel from spraying out.

<<D>> FUEL TANK BAND/FUEL TANK ASSEMBLY REMOVAL

1. Support the fuel tank with a transaxle jack.
2. Remove the fuel tank band and fuel tank assembly as follows.

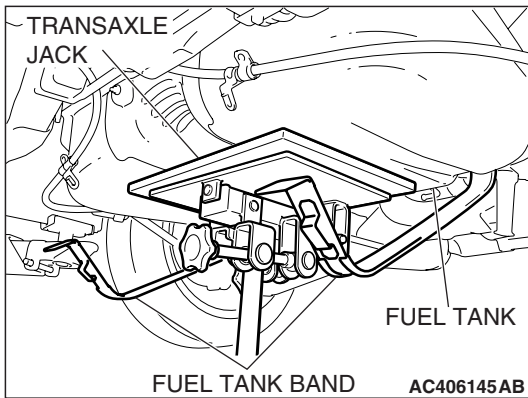

- (1) Remove the front securing nut of the fuel tank band.
- (2) Tilt the fuel tank assembly forward and lower it gradually to remove it.
- (3) Remove the fuel tank band.

<<E>> FUEL PUMP MODULE REMOVAL

⚠ CAUTION

- When removing the fuel pump module from the fuel tank, be careful not to spill the fuel remaining in the fuel pump module.
- When withdrawing the fuel pump module from the fuel tank, be careful not to damage the module unit and the float.

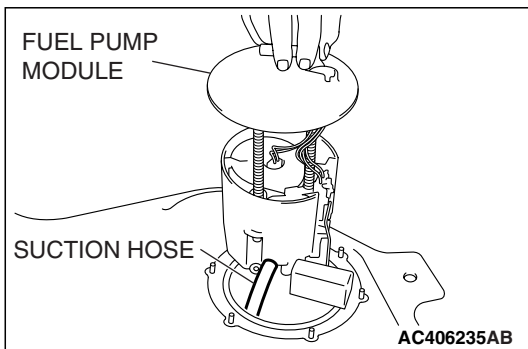
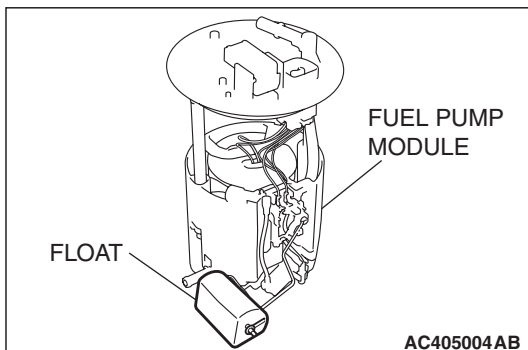

1. Drain the fuel remaining in the fuel pump module while removing the fuel pump module from the service hole.
2. Disconnect the suction hose and remove the fuel pump module from the fuel tank.

<<F>> FUEL LEVEL SENSOR (SUB) REMOVAL

⚠ CAUTION

When withdrawing the fuel level sensor (sub) from the fuel tank, be careful not to damage the sensor unit and the float.

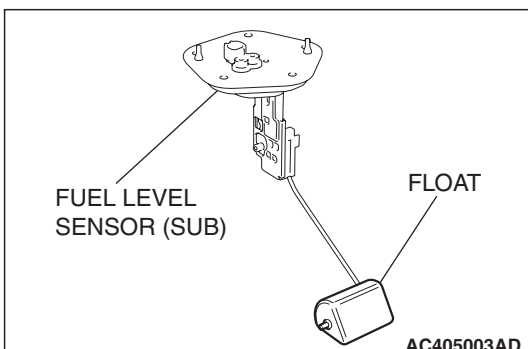

INSTALLATION SERVICE POINTS

>>A<< FUEL LEVEL SENSOR (SUB) INSTALLATION

⚠ CAUTION

When inserting the fuel level sensor (sub) into the fuel tank, be careful not to damage the sensor unit and the float.

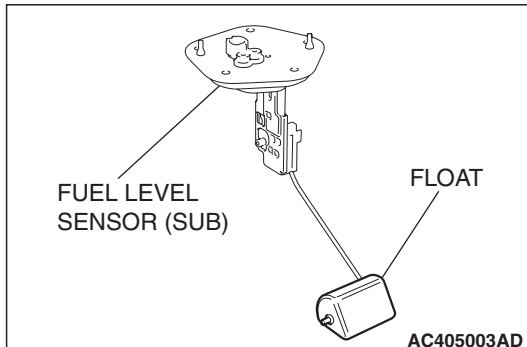

>>B<< FUEL PUMP MODULE INSTALLATION

⚠ CAUTION

- When installing the fuel pump module into the fuel tank, be careful not to damage the module unit and the float.
- Check the fuel level sensor moving part of the fuel pump module works smoothly and then install the fuel pump module into the fuel tank.

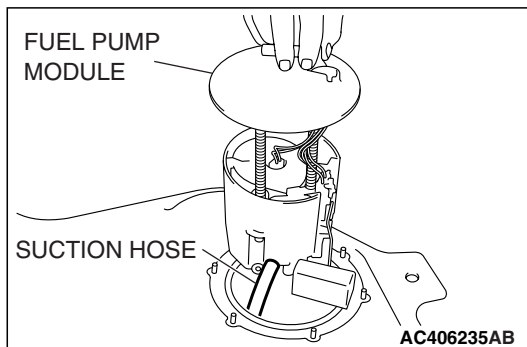
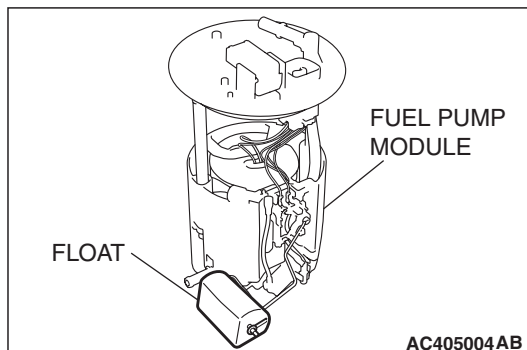

1. Connect the suction hose to the fuel pump module.
2. Install the fuel pump module into the fuel tank.

>>C<< FUEL HIGH-PRESSURE HOSE CONNECTION

⚠ CAUTION

After installing, slightly pull the fuel high-pressure hose and ensure that there is no disengaged fuel high-pressure hose. Also confirm that there is approximately 3 mm (0.12 inch) play at this time.

>>D<< FUEL TANK BAND/FUEL TANK ASSEMBLY INSTALLATION

1. Raise the fuel tank assembly carefully with a transaxle jack.
2. Ensure that the fuel tank assembly does not interfere with surrounding parts. Then install the fuel tank band and tighten the mounting nuts to the specified torque.

Tightening torque: $26 \pm 5 \text{ N} \cdot \text{m}$ ($19 \pm 4 \text{ ft}\cdot\text{lb}$)

3. Again, ensure that the fuel tank assembly does not interfere with surrounding components. If the fuel tank assembly interferes surrounding components, remove the fuel tank assembly and the tank band and reinstall them.

INSPECTION

M1135002000296

FUEL TANK SHUT-OFF VALVE CHECK

Check that the flapper of the fuel shut-off valve opens and closes as shown in the illustration.

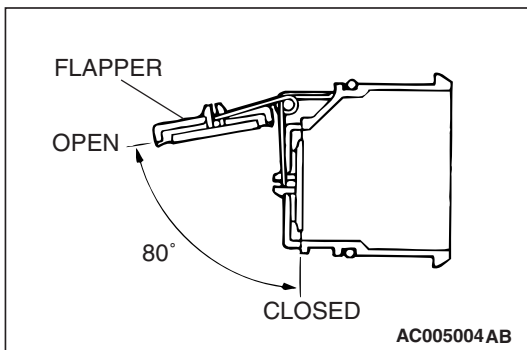

FUEL TANK DIFFERENTIAL PRESSURE SENSOR CHECK

Require Special Tool:

- MB991658: Test Harness Set
1. Disconnect the fuel tank differential pressure sensor connector and connect special tool MB991658 between the terminals of the disconnected connector.
 2. Turn the ignition switch to "ON" position and measure the voltage between terminal 1 and ground.

Standard value: 2.0 – 3.0 V

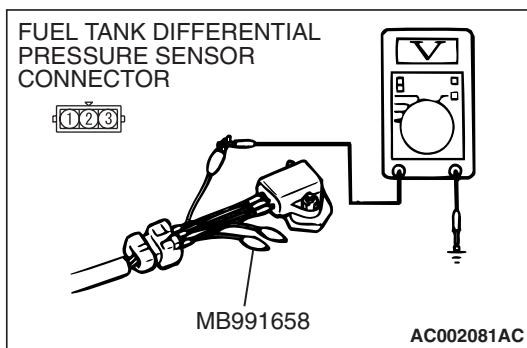

SPECIFICATIONS**FASTENER TIGHTENING SPECIFICATION**

M1135003900388

ITEM	SPECIFICATION
Fuel tank band nut	26 ± 5 N·m (19 ± 4 ft-lb)

SERVICE SPECIFICATION

M1135000300291

ITEM	STANDARD VALUE
Fuel tank differential pressure sensor output voltage V	2.0 – 3.0